

Automotive Transient and Overcurrent Protection Filter Reference Design



Description

The TIDA-020040 reference design showcases a protection system for voltage and current transient events typically found in automotive systems. This reference design optimizes functionality, size, and protection capabilities while not sacrificing power delivery for premium audio amplifiers.

Resources

TIDA-020040	Design Folder
INA302-Q1	Product Folder
LM7481-Q1	Product Folder



[Ask our TI E2E™ support experts](#)

Applications

- [Automotive Head Unit](#)
- [Automotive External Amplifier](#)
- [Digital Cockpit Processing Unit](#)

Features

- LM74810-Q1 ideal diode controller with external back-to-back N-channel MOSFETs for over-voltage protection and to emulate an ideal diode rectifier
- INA302-Q1 provides over-current protection along with analog current monitoring
- Components in the system ensure safe operations between the battery and the A-line filter feeds the audio amplifiers downstream.
- Designed in a 4in X 3.5in board

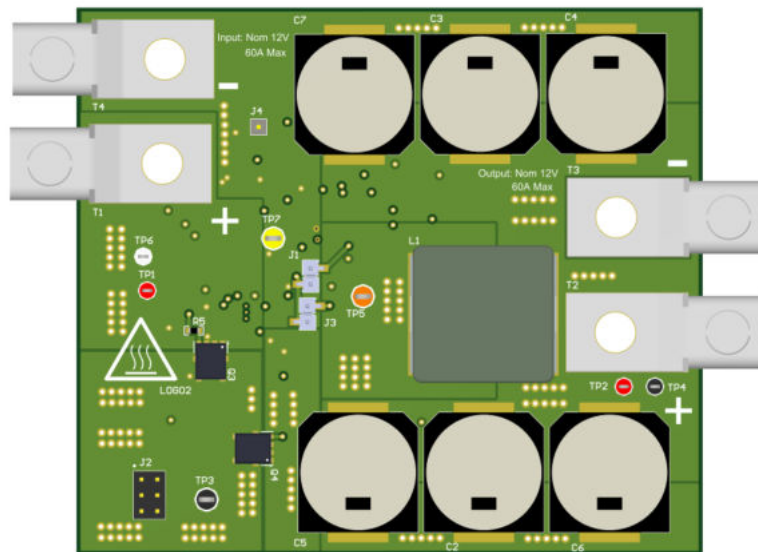

1 System Description

TIDA-020040 is designed to provide input protection for premium audio systems. This reference design offers customizable functionality while maintaining a small form factor with ideal thermal dissipation. This filter can be used to protect your premium audio amplifiers from the standard transients seen across the automotive industry.

This design uses LM74810-Q1 to detect and respond to over-voltage events, and INA302 to measure current and respond to over-current events. Both of these ICs provide a great level of customization to meet any specific project needs, this includes multi-stage over-current detection for warning lights or delayed transient response, choosing a clamp vs. shut down over-voltage response, and the ability to sense current bidirectionally.

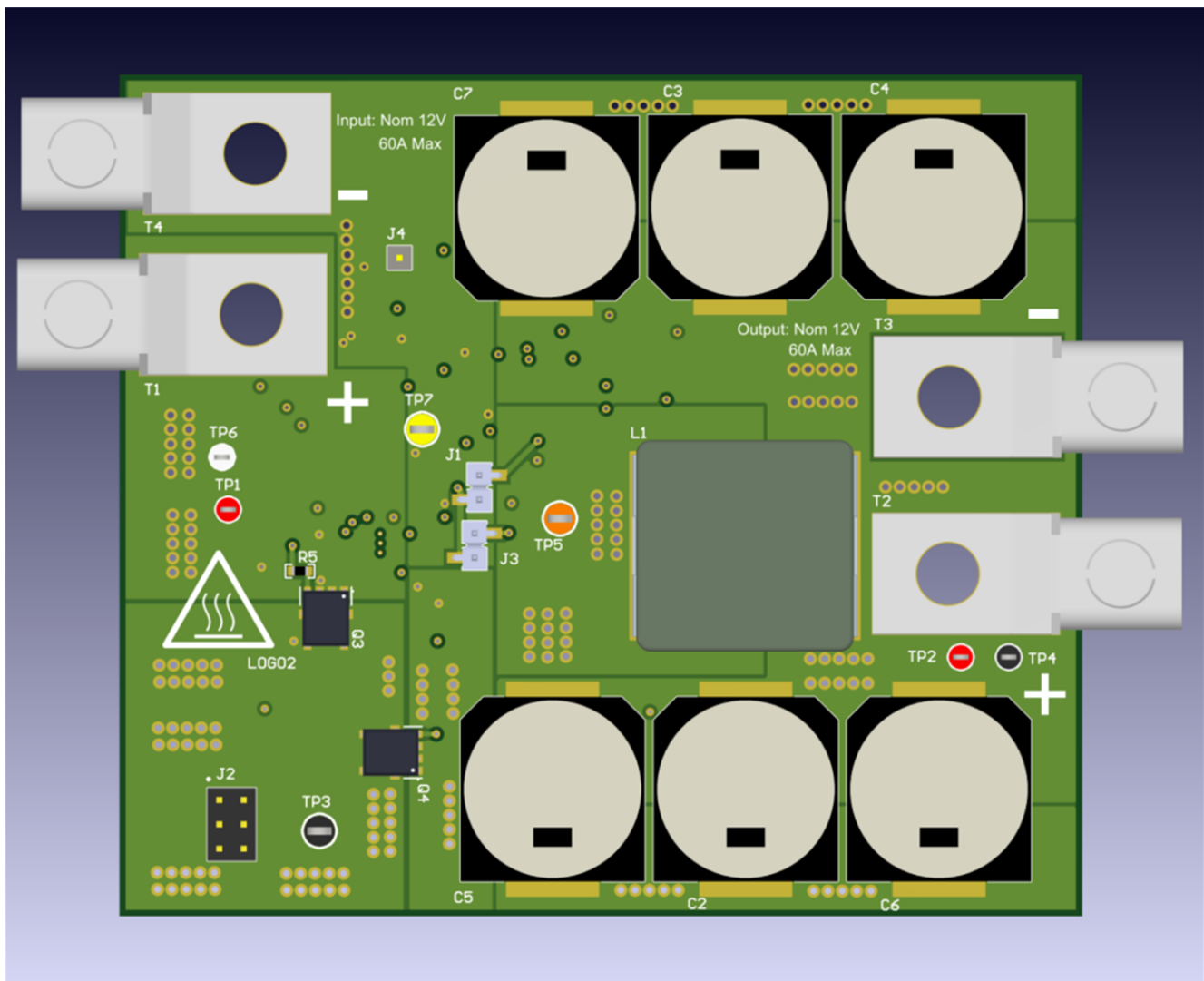

Figure 1-1. TIDA-020040 Filter Design

1.1 Key System Specifications

Table 1-1. Key System Specifications

PARAMETERS	COMMENTS	MIN	TYP	MAX	UNIT
V_{in}	Input Voltage	9	12	18	V
V_{limit}	Overvoltage Limit		18		V
I_{max}	Overcurrent Limit			60	A
t_{oc}	Overcurrent Timing Threshold		100		ms
f_{out}	Output Filter Cutoff Frequency		1		kHz

2 System Overview

2.1 Block Diagram

The block diagram for the design is shown in [Figure 2-1](#). INA302-Q1 provides an analog current measurement output to be read by a microcontroller as well as two active low comparator outputs to signal if the current is above the threshold set. The two active low comparator thresholds can be independently set and one of the comparators can be set to have a delay through an external capacitor. The two comparator outputs serve as the inputs for the OR-gate which drives the enable signal for LM74810.

Connecting the overcurrent signal to the enable pin of LM74810 allows off turning off the ideal diode controller when there is an overcurrent condition. Using both comparator outputs of INA302 along with the OR-gate provides flexibility in how the comparator outputs are used. Using both comparators at different thresholds can provide a warning signal for sustained high current before reaching the overcurrent threshold as well as allow short current transients without triggering a fault condition. LM74810 drives back to back N-channel MOSFETs enabling reverse polarity protection, reverse current blocking, in-rush current control, and overvoltage protection. TPS7B69 is an LDO that provides the INA302 and the OR gate with a 5 V VCC from the battery voltage.

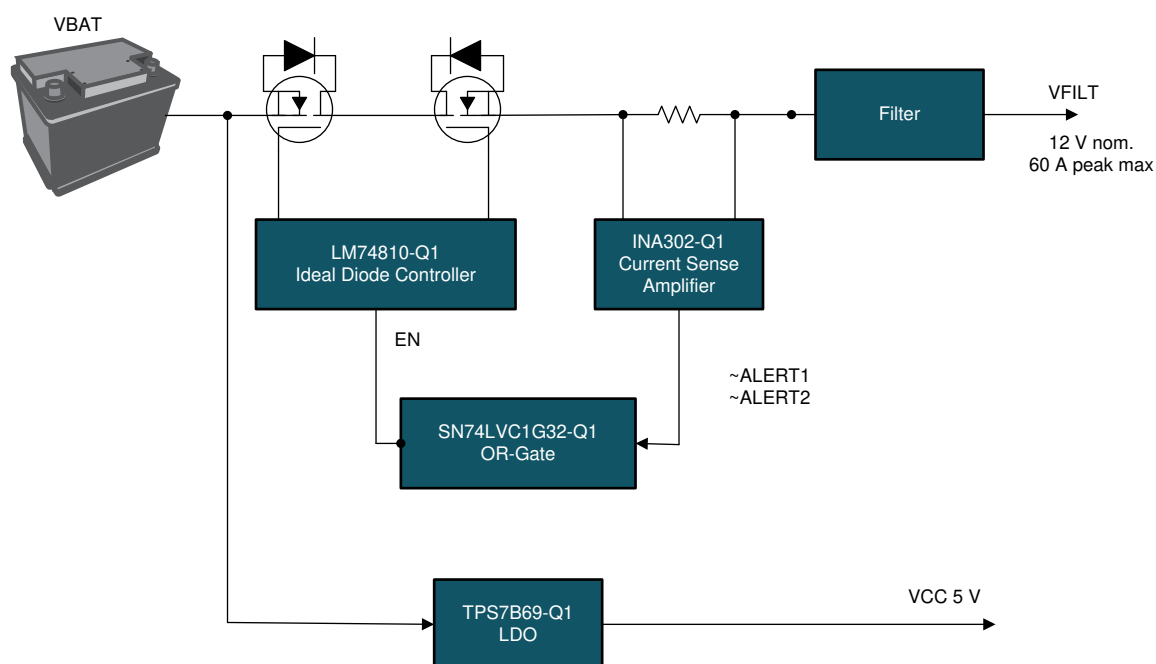

Figure 2-1. TIDA-020040 Block Diagram

2.2 Design Considerations

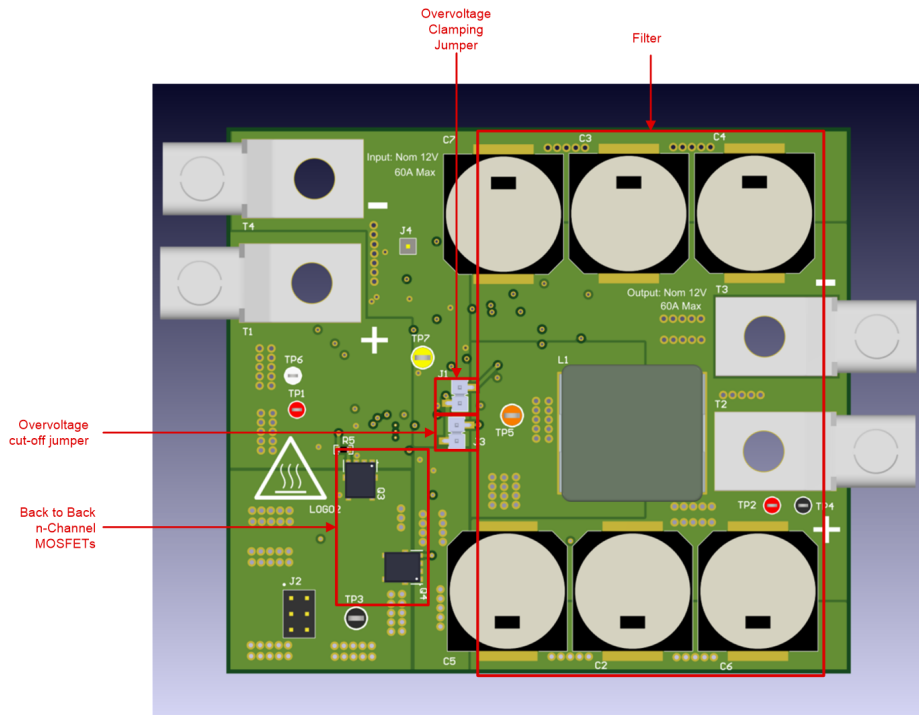

Figure 2-2. TIDA-020040 PCB Front

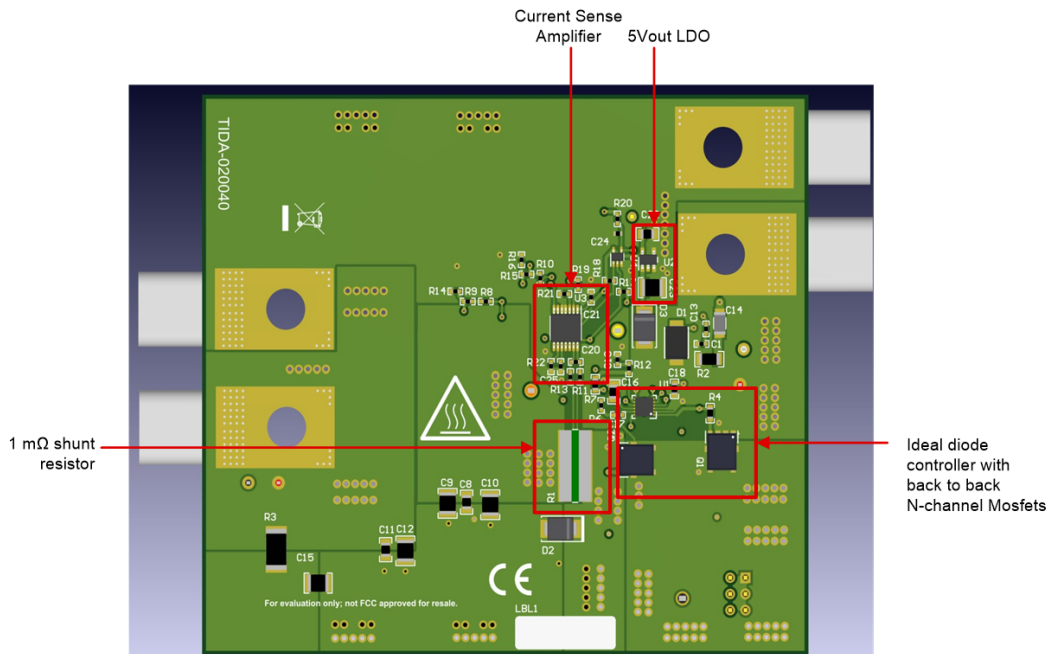

Figure 2-3. TIDA-020040 PCB Back

2.2.1 Ideal Diode Design Overview

LM74810-Q1 is an ideal diode controller that drives and controls external back to back N-Channel MOSFETs. The first MOSFET to replace a Schottky diode and the second MOSFET allows load disconnect switch control. LM74810-Q1 has a wide input supply 3 V to 65 V, ideal for protection and control of 12 V automotive battery systems. Through controlling the MOSFETs, LM74810-Q1 provides reverse input protection, Reverse current blocking, in-rush current control, and adjustable over voltage protection.

TIDA-020040 controls two sets of MOSFETs in parallel to aid in decreasing power dissipation from the MOSFETs R_{dson} at high currents.

Adjustable over voltage protection is controlled through a resistor divider and connection to the OV pin of LM74810-Q1 which goes to an internal comparator with a set 1.23 V reference. When the voltage applied to OV is higher than the 1.23 V reference, overvoltage is triggered.

The design allows shorting J1 connector for over voltage clamping or shorting J3 connector for over voltage cut-off. For both connections, the resistor divider is the same to allow over voltage to trigger at 18.2 V.

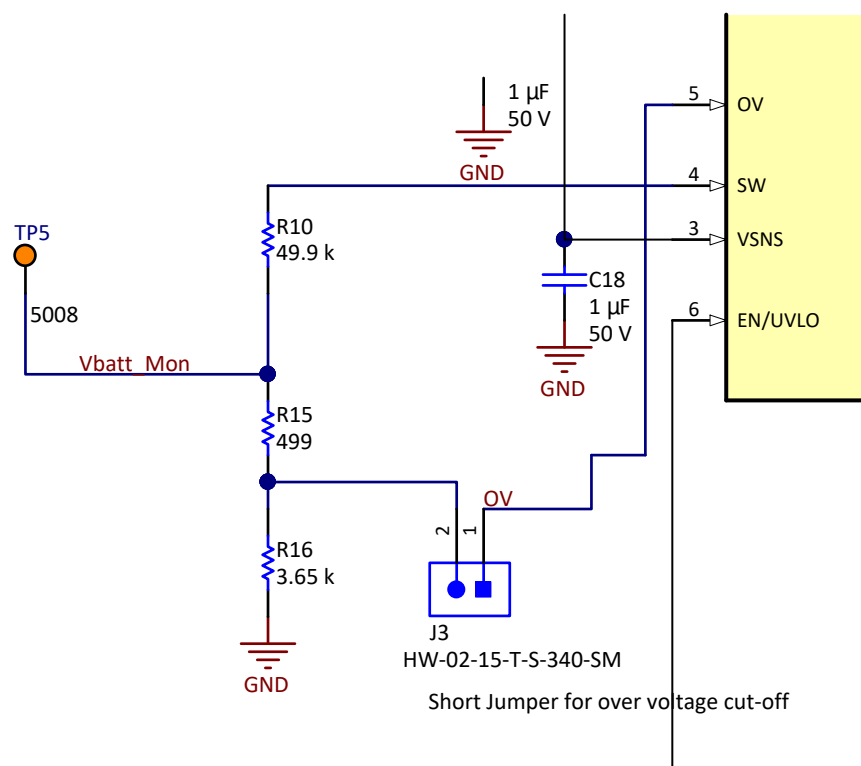

Figure 2-4. Over Voltage Resistor Divider Schematic

2.2.2 Current Sensing Amplifier Design Overview

INA302-Q1 feature a high common-mode current sensing amplifier and two high-speed comparators. The two high-speed comparators have adjustable over current thresholds that are independent of each other enabling the ability to detect currents that are out of range. The response of comparator 1 is under 1µs and the alert response of comparator 2 is set through an external capacitor on the delay pin ranging from 2µs to 10s.

Equation 1 provides a way to determine the delay response of comparator 2 based on the capacitor value chosen. Values for and are typically 1.22 V and 5 µA respectively.

The design has a default of 470pF resulting in a of roughly 117 µs. INA302 has two modes available for the comparators based on whether the LATCH pins are pulled high or low. When the LATCH pin is low, INA302 is in transparent mode where the ALERT pins will follow the current sensed at the inputs. As such the ALERT pins will go back to normal if the current falls below the overcurrent threshold. When the LATCH pins are pulled high, the INA302 is in latched mode and once overcurrent is detected the ALERT pins will give an overcurrent signal until the LATCH pins are toggled to reset the ALERT pins. Latched mode is ideally used with an MCU that can toggle the LATCH pins low for at least 100ns.

$$t_{\text{DELAY}} = \left\{ \frac{C_{\text{DELAY}} \times V_{\text{TH}}^{1.5 \mu\text{s}}}{I_{\text{D}}} + 2.5 \mu\text{s} \right. \quad (1)$$

Equation 2 provides a way to determine the resistor value needed on the LIMIT pins to get the desired current threshold value. The GAIN value for the INA302A2 device used is 50 V/V and is typically 80 µA. The design has a default a 1mΩ current sense resistor, a value for both LIMIT1 and LIMIT2 pins of 37.4KΩ to get a roughly 60A.

$$R_{\text{LIMIT}} = \frac{(I_{\text{TRIP}} \times R_{\text{SENSE}} \times \text{GAIN}) + V_{\text{REF}}}{I_{\text{LIMIT}}} \quad (2)$$

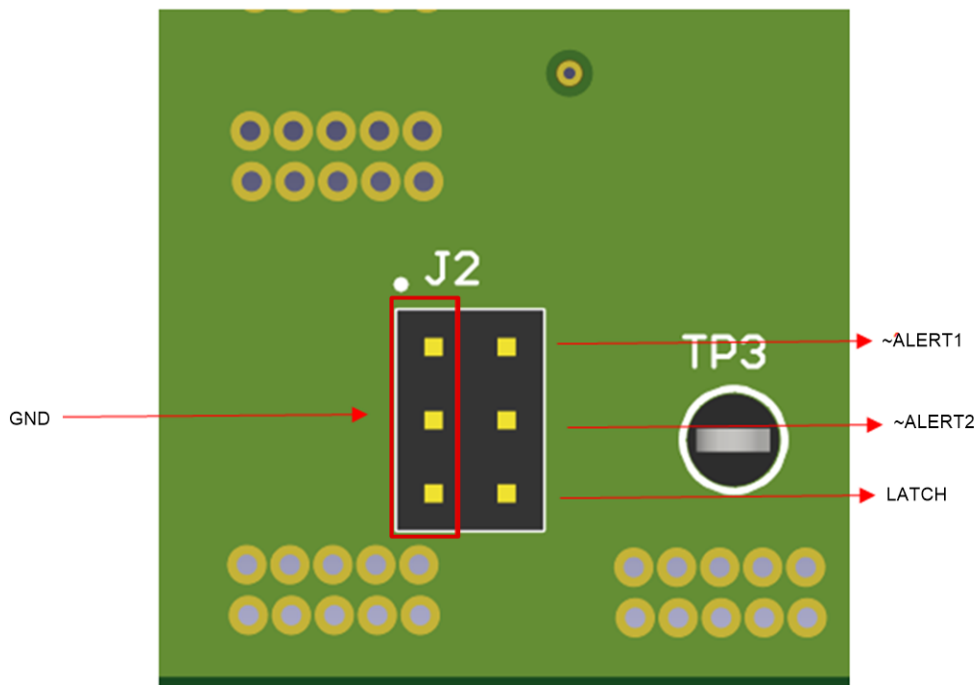

Figure 2-5. TIDA-020040 Design J2 Connectors

2.2.3 OR Gate Design Overview

SN74LVC1G32-Q2 is a 2-input positive OR gate designed for 1.65- to 5.5V VCC operation. It is designed to perform Boolean OR function on the ALERT1 and ALERT2 pins. The OR gate is tied to the enable pin of LM74810, allowing the device to turn off when both ALERT1 and ALERT2 are pulled low from detecting an overcurrent conditions from their comparators. The configuration allows flexibility by using both ALERT1 and ALERT2 comparator output pins which have independent overcurrent trigger levels as well as independent response times as shown in Current Sensing Amplifier Design Overview section. Comparator 2 can be set to trigger at a lower level relatively to comparator 1, allowing an MCU to read ALERT1 to serve as a sustained high current warning. Comparator 1 can be set to a higher trigger level, pulling low during an overcurrent condition.

2.2.4 MOSFET Selection

2.2.4.1 Blocking MOSFET

Selection of the blocking MOSFET requires consideration of electrical parameters which includes maximum source current through body diode and the R_{DS(ON)} of the device.

Selection of the MOSFET along with TVS diode should ensure that of the MOSFET is not surpassed in automotive transient events and any anticipated fault conditions. For this design 60 V MOSFETS are used with a single bidirectional TVS device. The MOSFETs chosen have a of ±20 V allowing safe operation when the maximum 14 V from the LM74810-Q1 is applied, the MOSFET plays a role in the conduction losses as well as reverse current detection by the ideal diode controller. As such, guidelines are given by the LM74810 data sheet for ranges for MOSFET selection based on the nominal operating current.

$$8 \text{ mV} / I_{\text{LOAD(NOMINAL)}} \leq R_{\text{DS(ON)}} \leq 50 \text{ mV} / I_{\text{LOAD(NOMINAL)}} \quad (3)$$

The range is provided above to serve as a guideline while keeping in mind the MOSFETs temperature resistance based on expected power dissipation.

2.2.4.2 Hot-Swap MOSFET

Similar to the blocking MOSFET selection, the rating should be sufficient to handle maximum system voltage and transient voltage events. In addition, rating should be higher than the 15 V maximum HGATE-OUT voltage. Power dissipation during inrush should be within the MOSFET's safe operating area.

2.2.5 TVS Input Diode Selection

TVS for 12 V battery systems should have a breakdown voltage higher than 24 V jump start voltage and 35 V suppressed load dump voltage while being lower than the 65 V maximum voltage rating for the LM74810-Q1 device. For negative voltages the TVS diode breakdown voltage should be higher than the reverse battery connection voltage and have a negative clamping voltage that does not exceed of the Q1 MOSFET. The design uses SMBJ36CA providing the necessary breakdown voltage and clamping voltage to provide suitable protection and is sufficient for ISO 7637-2 pulse 1.

2.2.6 Inrush Current

Inrush limiting is achieved with LM74810-Q1 by placing a capacitor to slow down the HGATE voltage ramp during power up. The capacitor value required depends on the desired inrush current value as well as the amount of output capacitance. Equation 4 shows how to calculate the capacitor value needed. In the equation, is typically being 53 μ A.

$$C_{dvdT} = \frac{I_{HGATE_DRV}}{I_{INRUSH}} \times C_{OUT} \tag{4}$$

Duration of the inrush current can be calculated by Equation 5.

$$dT_{INRUSH} = \frac{12}{I_{INRUSH}} \times C_{OUT} \tag{5}$$

2.3 Highlighted Products

2.3.1 LM74810-Q1

The LM74810-Q1 ideal diode controller drives and controls external back to back N-Channel MOSFETs to emulate an ideal diode rectifier with power path ON/OFF control and over voltage protection. The wide input supply of 3V to 65V allows protection and control of 12-V and 24-V automotive battery powered ECUs. The device can withstand and protect the loads from negative supply voltages down to -65 V. An integrated ideal diode controller (DGATE) drives the first MOSFET to replace a Schottky diode for reverse input protection and output voltage holdup. A strong charge pump of 3mA with 50mA peak GATE source current driver stage and short turn ON and turn OFF delay times ensures fast transient response ensuring robust and efficient MOSFET switching performance during automotive testing such as ISO16750 or LV124 where an ECU is subjected to input short interruptions and AC superimpose input signals up to 200KHz frequency. With a second MOSFET in the power path the device allows load disconnect (ON/OFF control) and over voltage protection using HGATE control. The device features an adjustable over voltage cut-off protection feature for load dump protection.

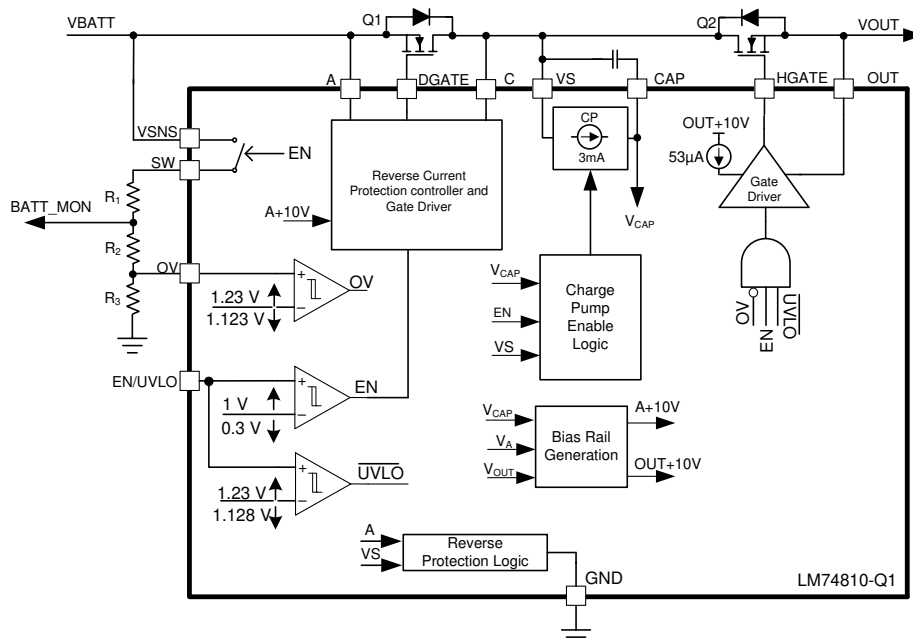

Figure 2-6. LM74810-Q1 Block Diagram

2.3.2 INA302-Q1

The INA302-Q1 and INA303-Q1 (INA30x-Q1) devices feature a high common-mode, bidirectional, current-sensing amplifier and two high-speed comparators to detect out-of-range current conditions. The INA302-Q1 comparators are configured to detect and respond to overcurrent conditions. The INA303-Q1 comparators are configured to respond to both overcurrent and under-current conditions in a windowed configuration. These devices feature an adjustable limit threshold range for each comparator set using an external limit-setting resistor. These current-shunt monitors can measure differential voltage signals on common-mode voltages that can vary from -0.1 V up to $+36$ V, independent of the supply. In addition, these devices will survive with common-mode voltages as high as 40 V.

The open-drain alert outputs can be configured to operate in either a transparent mode (output status follows the input state), or in a latched mode (alert output is cleared when the latch is reset). The alert response time for comparator 1 is under 1 μ s, and the alert response for comparator 2 is set through an external capacitor ranging from 2 μ s to 10 s.

These devices operate from a single 2.7 -V to 5.5 -V supply, drawing a maximum supply current of 950 μ A. The devices are specified over the extended operating temperature range of -40°C to $+125^{\circ}\text{C}$, and are available in a 14-pin TSSOP package.

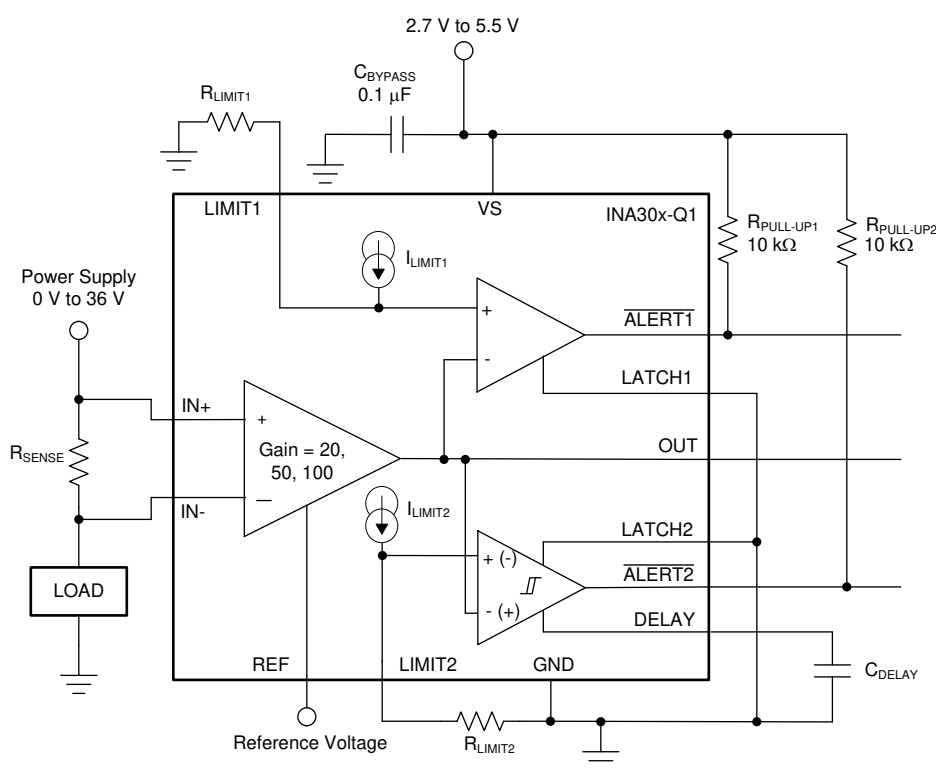

Figure 2-7. INA302-Q1 Block Diagram

3 Hardware, Software, Testing Requirements, and Test Results

3.1 Hardware Requirements

3.1.1 Getting Started

1. Short jumper J1 for over voltage clamping or short jumper J3 for over voltage cut-off.
2. Connect Latch header in J2 to VCC (TP6) for latched mode.
3. Latched mode requires J2 to be pulled low for at least 100ns to toggle the LATCH pins of the INA302 device to clear the alert and for LM74810 to become enabled.
4. Connect J4 to voltmeter to be able to read current sensed by INA302.
5. Connect power supply to input lug connectors. Nominal voltage is 12 V. The power supply must be able to source up to 60A to trigger default over current conditions of the design.
6. Connect electronic load to output lug. The electronic load must be able to sink up to 60A and the corresponding power rating.

3.1.2 Testing and Results

3.1.2.1 Over-Voltage Protection Cut-Off Mode

Over voltage cut off mode is implemented by shorting together J3 connector. By doing so the OV pin will be connected to the resistor divider connected to the voltage between the back to back N-channel MOSFETs.



Figure 3-1. Over-Voltage Protection Cut-Off Mode

Figure 3-1 shows the output shutting off when the input reaches roughly 18.2 V which corresponds to the threshold placed by the resistor divider. When the OV comparator detects the overvoltage, the HGATE will turn off disconnecting the input from the output. Output voltage will stay low until the comparator detects the input voltage being lower than the selected threshold.

3.1.2.2 Over-Voltage Protection Clamping-Mode

Over voltage clamping mode is implemented by shorting together the j 1 connector. By doing so the OV pin will be connected to the resistor divider which is connected to the source of the HGATE driven MOSFETs.

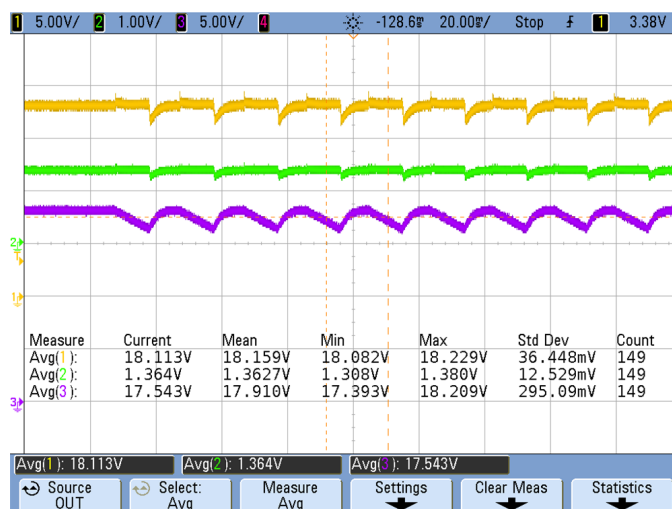

Figure 3-2. Over-Voltage Protection Clamping Mode

Figure 3-2 shows over-voltage clamping with the HGATE MOSFETs switching to regulate the output. By having the OV pin connected to the resistor divider at the source of the HGATE driven MOSFETs, the MOSFETs will switch on and off clamping the voltage at the output.

3.1.2.3 ISO7637-2 Pulse 1

ISO7637-2 Pulse 1 test consists of battery disconnection where the voltage goes to zero volts and followed by -100 V. Figure 3-3 shows the typical waveform as well as the parameters for the test performed. The LM74810 should prevent reverse current as well preventing the output voltage from going negative in order to protect the rest of the circuit. Proper TVS selection performs a large role in the test to ensure the negative voltage is clamped within the 85 V operating maximum voltage across cathode to anode of the LM74810 as well as not exceed the of the 60 V MOSFETs.

- U_s : 100 V
- Rise Time t_r : 1us
- Output Resistance: 10 Ohms
- Pulse Width t_d : 2ms
- T_2 : 200ms

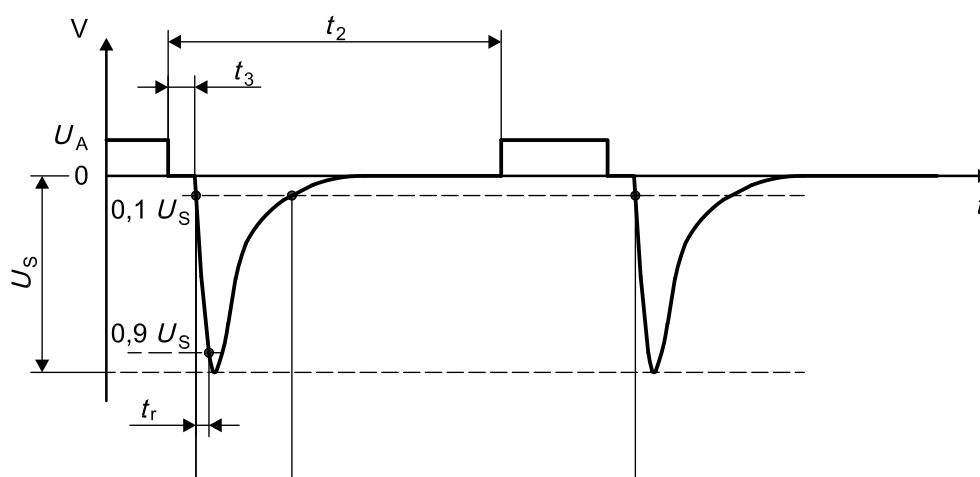

Figure 3-3. ISO7637-2 Pulse 1

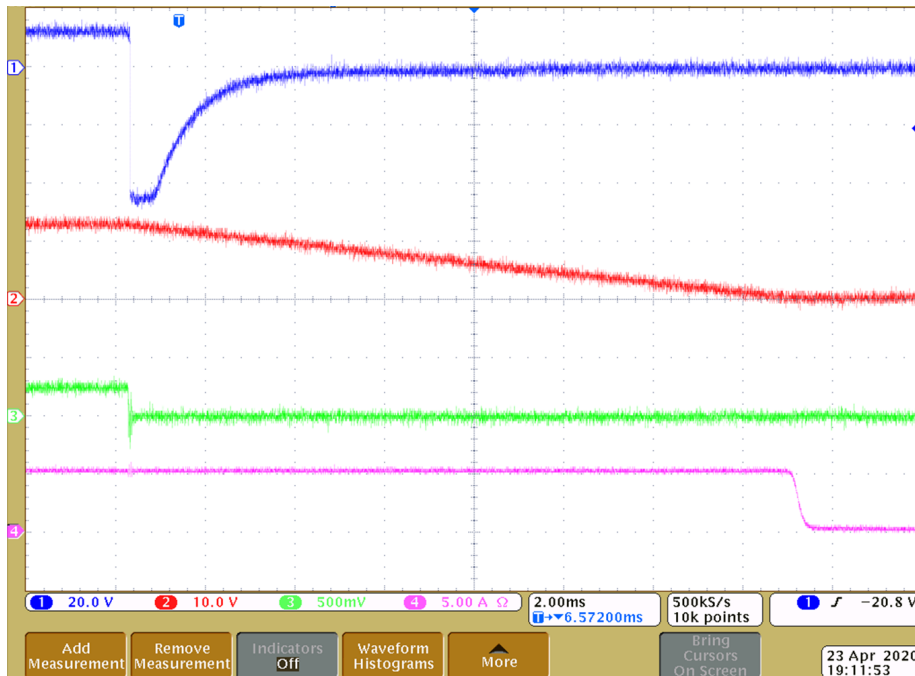

Figure 3-4. ISO7637-2 Pulse 1 Test

As shown in Figure 3-4, the yellow trace is the input voltage which goes negative and the TVS diode clamps the input at roughly -45 V. The blue trace is the output which decreases and the green trace is the output current to the e-load which continues to draw current until the output goes to 0 V. The pink trace is the INA302 output.

3.1.2.4 Overcurrent Protection

Overcurrent protection testing primarily consisted of ensuring that the INA302 responded appropriately to increases in current and for the current sense amplifier to turn off LM74810 if an over-current event occurs. As mentioned in section 2.1.1, the INA302 can operate in latch mode or transparent mode. The testing shown in Figure 3-5 and Figure 3-6 was performed in latch mode.

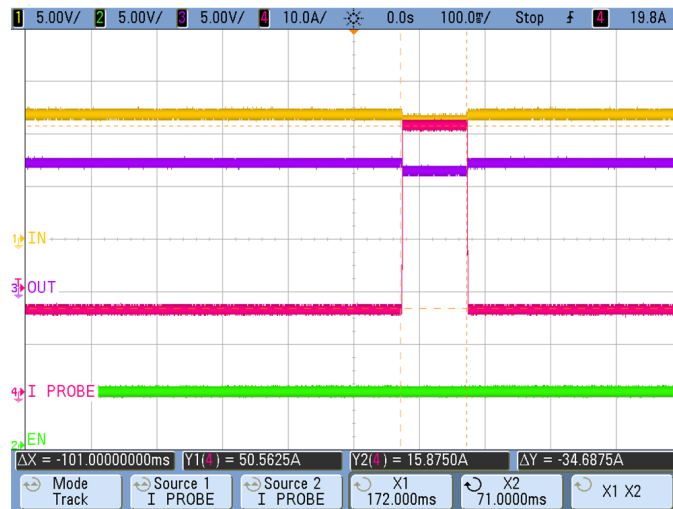

Figure 3-5. Normal Transient Current

As shown in Figure 3-5, the red trace is the current output which sees an increase in current from 15A to 50A for 100ms. The overcurrent threshold is at 60A and as such the EN pin stays high in normal transient operation.

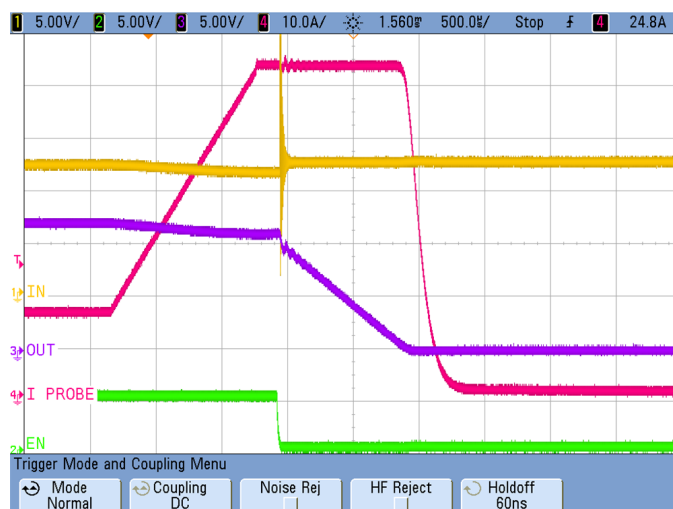

Figure 3-6. Latch Mode Overcurrent Protection

As shown in Figure 3-6, the red trace is the current output to the e-load which experiences a 62A transient for 100ms. A 62A transient will trigger the overcurrent protection if the transient last longer than roughly 100 μ s. The green trace, which is the enable signal, pulls low during the fault conditions and will remain low until the INA302 LATCH pins are toggled to clear the fault. Having the enable signal pulled low, will turn off the MOSFETs, disconnecting the output from the input, resulting in a decrease in output voltage.

3.1.2.5 Load Dump

Suppressed load dump testing was done with a 35 V max transient pulse. The load dump transient is shown in the yellow trace in Figure 3-7.

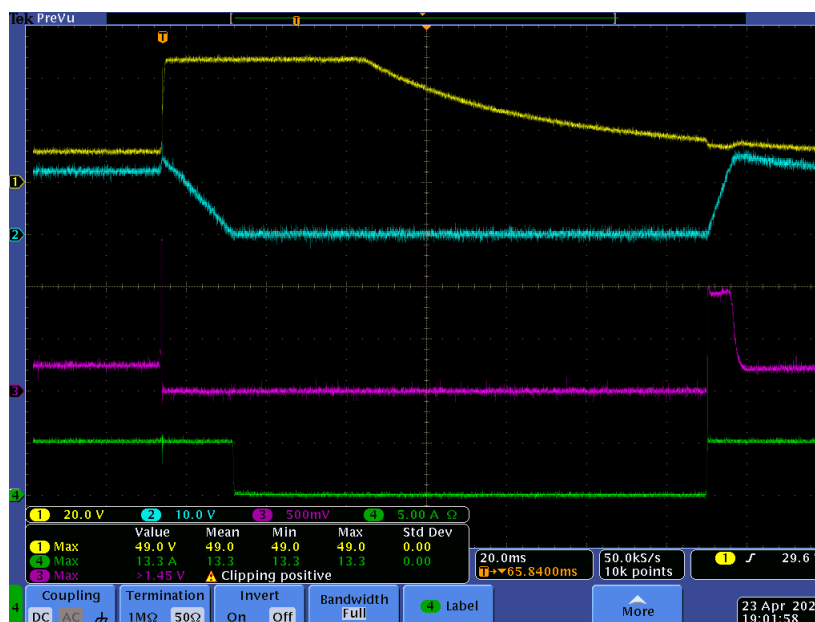

Figure 3-7. Suppressed Load Dump Test

Over-voltage protection is triggered by the LM74810 device when input is higher than the 18.2 V threshold that is set. The blue trace shows the output voltage where it decreases as the HGATE driven MOSFETs is turned off to protect any components downstream from the high voltage at the input. Once the high voltage transient ends, the MOSFETs will turn on again as shown in Figure 3-7. Load dump test demonstrates the inrush limiting feature

by the LM74810 device as the inrush current is limited to roughly to 15A. The green trace is the output current delivered to e-load.

3.1.2.6 Cold Crank, Warm Start, and Cold Start

Cranking pulse testing is performed using Texas Instruments, [Cranking Simulator for Automotive Applications Test Report](#) which functions as an automotive cranking simulator. The test waveforms available are shown below. Testing is done to ensure design operates properly when there is a drop in the battery voltage as seen in the different waveforms.

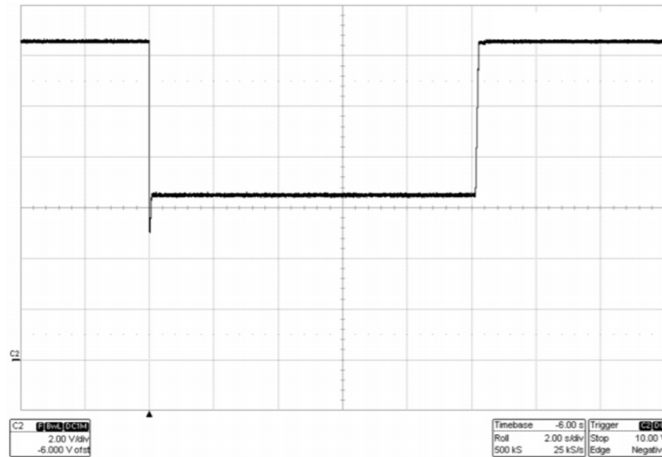

Figure 3-8. 2s/div DaimlerChrysler Engine-Cranking Pulse, DC-10615

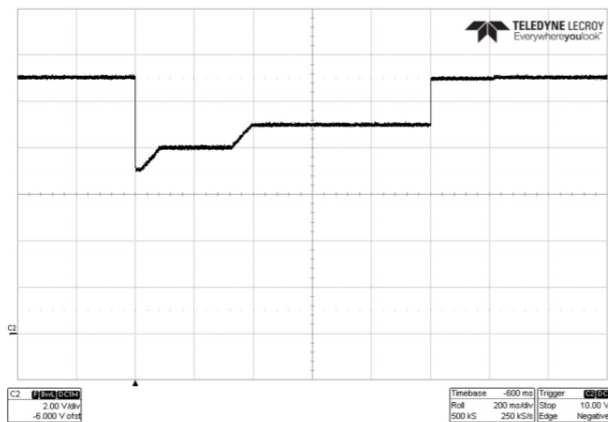

Figure 3-9. 200ms/div Volkswagen Warm-Start Test Pulse, VM80000

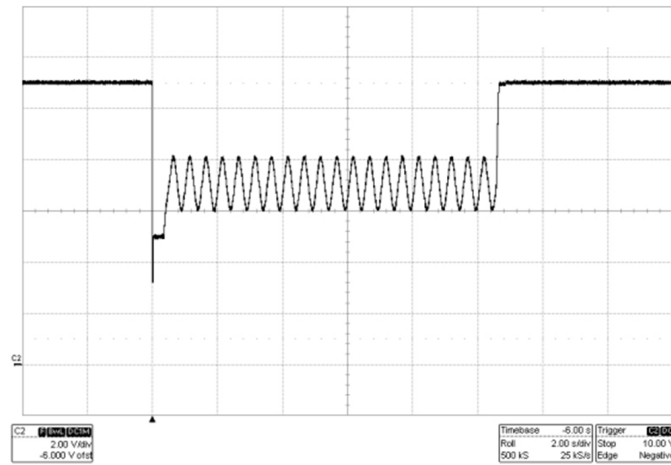

Figure 3-10. 2s/div Volkswagen Cold-Start Test Pulse, VW80000

3.1.2.6.1 Cold Crank

Cold crank testing is performed to ensure the design prevents reverse current during conditions where the input is lower than the output.

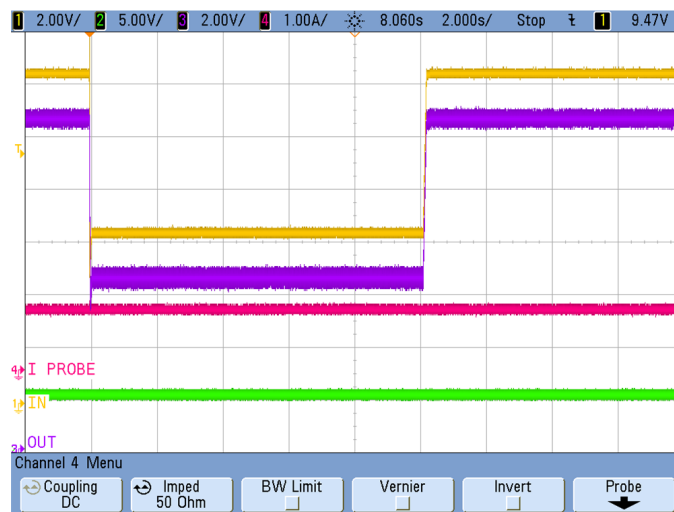

Figure 3-11. Cold Crank Waveform

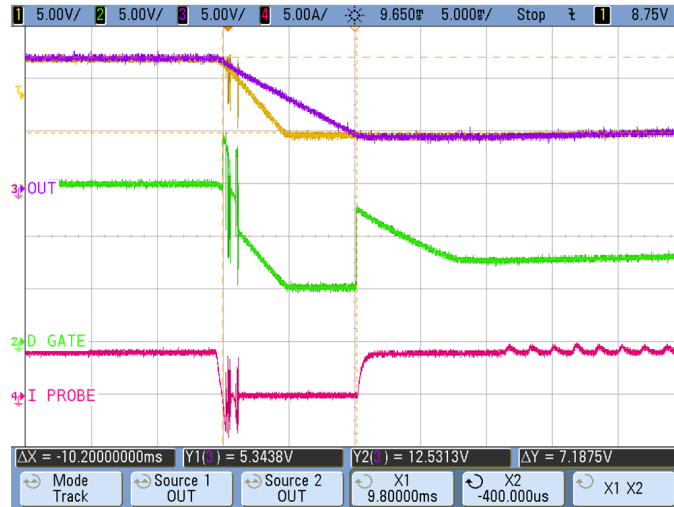

Figure 3-12. Cold Crank Reverse Current Testing

As shown in Figure 3-11, the input voltage drops to be lower than the output voltage for a period of time before eventually moving back to normal voltage levels. In these cold crank events, LM74810 provides reverse current blocking through the use of the DGATE driven MOSFETs. As shown in Figure 3-12, the green trace which is the DGATE voltage, turns off when the input voltage drops to prevent reverse current to flow back to the battery. For the testing shown in Figure 3-12, the current load is set to a 4A load.

3.1.2.6.2 Warm Start

Warm Start testing is performed to ensure the design functions as appropriate during a warm-start event. Warm Start sees a decrease in battery voltage resulting in the need to ensure the reverse current blocking feature works as intended. As shown in Figure 3-14, the DGATE pulls low when the output voltage is higher than the input voltage to make sure reverse current blocking takes place.

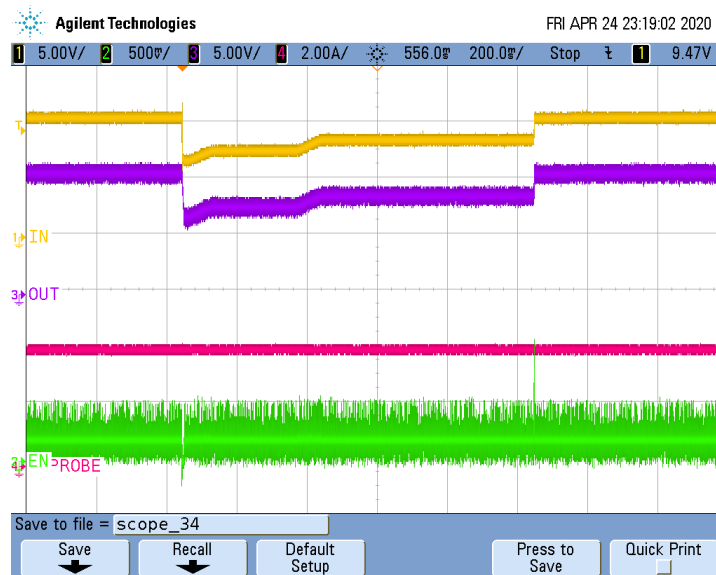

Figure 3-13. Warm Start/Start Stop Waveform



Figure 3-14. Warm Start Testing

3.1.2.6.3 Cold Start

Cold Start is performed in a similar fashion as the cranking pulse tests shown before. Waveform seen at the input is shown in Figure 3-15. A drop of current is shown in Figure 3-16 as the blocking MOSFET turns off to prevent reverse current from flowing.

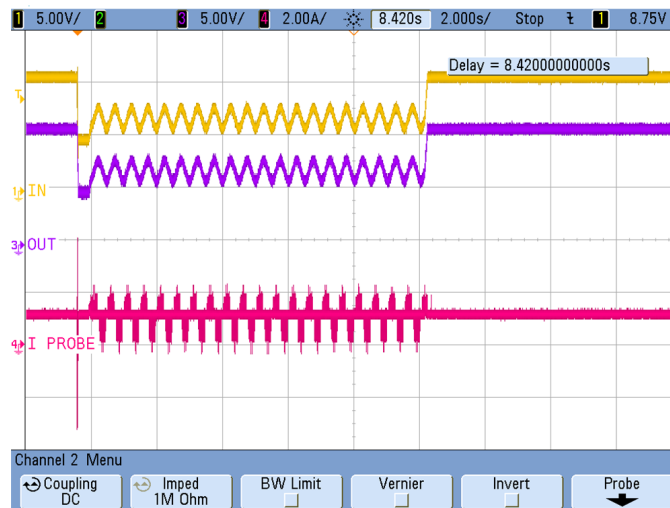

Figure 3-15. Cold Start Waveform

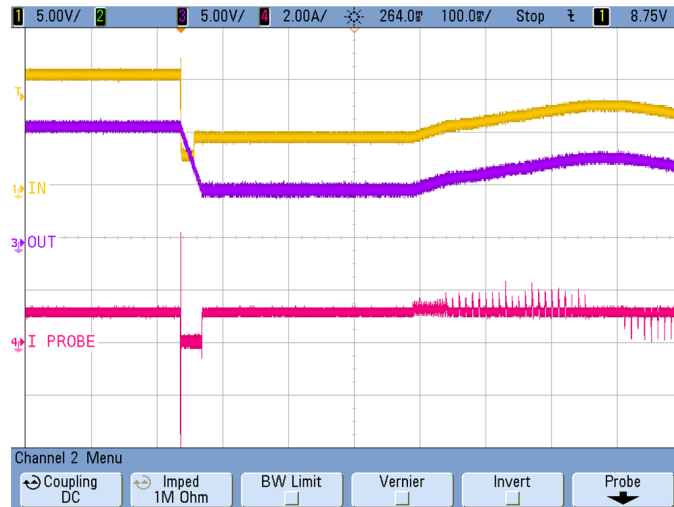

Figure 3-16. Cold Start Testing

3.1.2.7 Standby Current

Standby current testing for the design requires removing the OR gate in order to set the enable pin low and put the LM74810 device into shutdown mode. Once the OR gate is removed and the LM74810 is placed into shutdown mode, the current measured during standby was roughly 900µA. A large portion of the current is attributed to the typical quiescent current of the INA302 device. Once the INA302 device was removed from the board, the standby current was roughly 17µA.

To achieve the standby current values required it is recommended to use a LDO that has an enable function to easily power off the INA302.

3.1.2.8 Currency Sense Accuracy

Current sense accuracy testing was performed for the design, beginning at low current levels and increasing the current up to 24A max. The shunt resistor value for the design was a 1mohm resistor and the IN302 had a gain of 50V/V. Table 3-1 includes currents measured by INA302 in comparison to the current being drawn by the E-load.

Table 3-1. Current Sensing Accuracy Test Data

ELOAD CURRENT	INA OUT (V)	INA OUT (A) OUT/(Rs*Gain)
0.53	0.02595	0.519
1.03	0.05092	1.0184
2.03	0.10082	2.0164
3.04	0.15157	3.0314
5.04	0.2513	5.026
10.05	0.50196	10.0392
15.03	0.7514	15.028
20.02	1.0016	20.032
24.03	1.202	24.04

4 Design and Documentation Support

4.1 Design Files

4.1.1 Schematics

To download the schematics, see the design files at [TIDA-020040](#).

4.1.2 BOM

To download the bill of materials (BOM), see the design files at [TIDA-020040](#).

4.2 Documentation Support

1. Texas Instruments, [Automotive Ideal Diode Controller with Active Rectification Driving B2B NFETs data sheet](#)
2. Texas Instruments, [36V, Bi-directional, 550kHz, 4V/ \$\mu\$ s, High-Precision Current Sense Amplifier with Dual Comparators data sheet](#)

4.3 Support Resources

[TI E2E™ support forums](#) are an engineer's go-to source for fast, verified answers and design help — straight from the experts. Search existing answers or ask your own question to get the quick design help you need.

Linked content is provided "AS IS" by the respective contributors. They do not constitute TI specifications and do not necessarily reflect TI's views; see TI's [Terms of Use](#).

4.4 Trademarks

TI E2E™ are trademarks of Texas Instruments.

All other trademarks are the property of their respective owners.

IMPORTANT NOTICE AND DISCLAIMER

TI PROVIDES TECHNICAL AND RELIABILITY DATA (INCLUDING DATA SHEETS), DESIGN RESOURCES (INCLUDING REFERENCE DESIGNS), APPLICATION OR OTHER DESIGN ADVICE, WEB TOOLS, SAFETY INFORMATION, AND OTHER RESOURCES "AS IS" AND WITH ALL FAULTS, AND DISCLAIMS ALL WARRANTIES, EXPRESS AND IMPLIED, INCLUDING WITHOUT LIMITATION ANY IMPLIED WARRANTIES OF MERCHANTABILITY, FITNESS FOR A PARTICULAR PURPOSE OR NON-INFRINGEMENT OF THIRD PARTY INTELLECTUAL PROPERTY RIGHTS.

These resources are intended for skilled developers designing with TI products. You are solely responsible for (1) selecting the appropriate TI products for your application, (2) designing, validating and testing your application, and (3) ensuring your application meets applicable standards, and any other safety, security, regulatory or other requirements.

These resources are subject to change without notice. TI grants you permission to use these resources only for development of an application that uses the TI products described in the resource. Other reproduction and display of these resources is prohibited. No license is granted to any other TI intellectual property right or to any third party intellectual property right. TI disclaims responsibility for, and you will fully indemnify TI and its representatives against, any claims, damages, costs, losses, and liabilities arising out of your use of these resources.

TI's products are provided subject to [TI's Terms of Sale](#) or other applicable terms available either on ti.com or provided in conjunction with such TI products. TI's provision of these resources does not expand or otherwise alter TI's applicable warranties or warranty disclaimers for TI products.

TI objects to and rejects any additional or different terms you may have proposed.

Mailing Address: Texas Instruments, Post Office Box 655303, Dallas, Texas 75265
Copyright © 2022, Texas Instruments Incorporated