

Schottky Diode Selection in Asynchronous Boost Converters

Travis Eichhorn

1 Boost Schematic

Asynchronous boost converters require a Schottky diode as the rectifying element due to the diode's low forward voltage and fast turn-on time. Because of these characteristics asynchronous boost converters can have as good as, or better efficiency, than synchronous boost converters. This is especially true when the boost conversion ratios (V_{OUT}/V_{IN}) are high, and the Schottky diode conduction time is low. [Figure 1](#) shows a typical boost converter used in an LCD backlight application. Circuits like these are good examples of how picking the right diode is important in achieving maximum efficiency and performance.

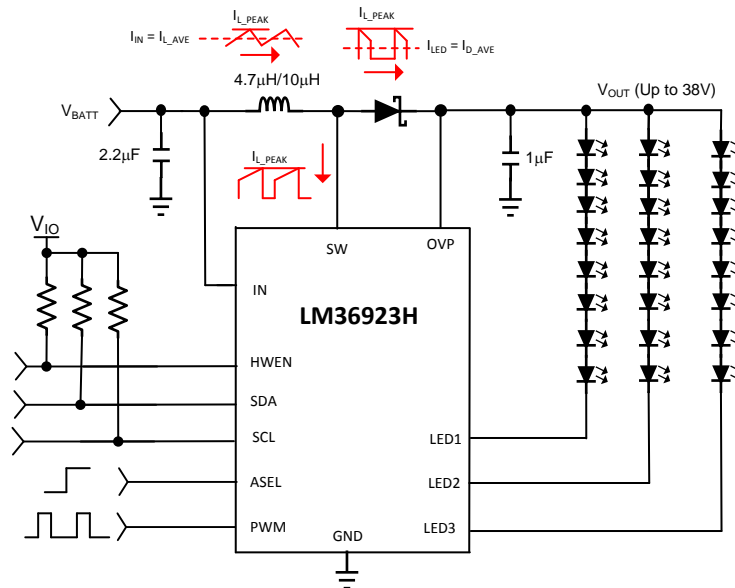

Figure 1. White LED Driver Boost Schematic

2 Diode Parameters

The diode parameters listed in diode data sheets are key in choosing the best Schottky diode. This can best be seen by comparing two separate Schottky diodes that have slightly different specifications. [Table 1](#) lists the parameters for each Schottky diode used in the comparison.

Table 1. Diode Parameters for Comparison

	VR_MAX	IDC_MAX	Repetitive IPEAK_MAX	VF(TYP at 100 mA)	CD (VR = 0)	IR (VR = 25 V, 25°C)	Case Size
Diode #1	30 V	200 mA	1 A	0.35 V	20 pF	10 µA	SOD-923
Diode #2	30 V	500 mA	4 A	0.32 V	160pF	10 µA	0402

2.1 Reverse Voltage

The main parameter for diode selection is the diode reverse voltage rating. This is the maximum voltage, which the diode can block when in the off state. When used as the rectifying diode in a boost converter the reverse voltage should be \geq the maximum voltage that the application can detect. For example, in the LM36923H (Figure 1), with 8 series LEDs the output voltage can potentially get up to $3.3 \text{ V} \times 8 + 0.26 \text{ V} = 26.66 \text{ V}$. The 0.26 V is the regulated headroom across the current sinks, so this must be included in the output voltage. Therefore, the chosen Schottky must have a VR rating of $> 27 \text{ V}$ (30 V is a typical rating).

Additionally, in I²C-controlled devices such as the LM36923H, there are normally a number of programmable overvoltage protection (OVP) thresholds. For instance, the LM36923H has options of 17 V, 24 V, 31 V, and 38 V. These are there to ensure that the output never goes above the set threshold in cases of an output open circuit or higher-than-expected string voltages. Therefore, the diode reverse voltage can be set to accommodate the OVP threshold or can be chosen to accommodate the maximum output voltage. However, Schottky diode VR ratings are often chosen to accommodate the OVP threshold in order to ensure diode survivability in case of output open circuit.

2.2 Current Rating

Schottky diodes typically have two current ratings: an average (or DC) rating, and a repetitive peak current rating. The average current rating should be \geq the average (DC) current of the diode. The repetitive peak current rating should be \geq the application peak operating inductor current. The currents are shown in red in Figure 1. The same peak inductor current goes through the inductor, the low side NMOS and the Schottky diode. Only the average current through each is different. Keep in mind that the peak current of the application is different than the peak current limit of the boost. The peak current of the application depends on V_{IN} , V_{OUT} , I_{OUT} , switching frequency, inductor, and efficiency. The peak current limit of the boost is a protection feature of the boost converter designed to protect the internal power NMOS in case of overcurrent conditions. Also, Schottky diodes sometimes have a maximum forward surge current listed. This is generally much higher than the repetitive peak current. For design purposes, the repetitive peak current should be used.

2.2.1 DC Current

Schottky average (DC) current rating must be \geq the Schottky DC current in the application. In Figure 1, this will be the total LED current (sum of strings 1, 2, 3).

2.2.2 Peak Current

The peak current rating that the Schottky detects is equal to the peak inductor current in the application. This can be estimated by Equation 1:

$$IL_PEAK = \left(\frac{ILED_TOTAL}{1 - D} + \frac{\Delta IL}{2} \right) \quad (1)$$

where D can normally be found by assuming the boost is operating in continuous conduction at max load and is given by:

$$D = \frac{VOUT_MAX - VIN_MIN \times efficiency}{VOUT_MAX} \quad (2)$$

ΔIL is the inductor current ripple and is given as:

$$\Delta IL = \frac{VIN \times D}{f_{SW} \times L} \quad (3)$$

As an example, for the 3 \times 8 LED configuration shown in Figure 1, the circuit parameters are given as ($VOUT_MAX = 26.7 \text{ V}$, $VIN_MIN = 2.7 \text{ V}$, $ILED_TOTAL = 60 \text{ mA}$, $efficiency = 87\%$, $f_{SW} = 1 \text{ MHz}$, $L = 10 \mu\text{H}$). Because the total load current is 60 mA, the diode DC current rating must be \geq to 60 mA. Then using (Equation 1) we get an IL_PEAK of 0.749 A, which means the Schottky diode repetitive peak current rating must be at least 750 mA.

Once the reverse voltage and current rating of the diode are properly selected, the Schottky diode can be further optimized for the best efficiency response by understanding the trade-offs between forward voltage, reverse current, and diode capacitance.

2.3 Diode Forward Voltage

Forward voltage is the sum of the voltage (VD) and diode resistance (RD) of the Schottky diode. This comes from the standard diode equation:

$$VF = VD + RD \times ID \tag{4}$$

where

$$VD = \frac{k \times T}{q} \times LN\left(\frac{ID}{IS}\right) \tag{5}$$

Note: IS is the negative of the diodes reverse current (see Section 2.5).

2.3.1 Diode Resistance (RD)

Typical Schottky VF is in the 0.2-V to 0.5-V range. Compare that to a PN junction diode with a 0.6-V to 1-V forward drop. As seen in Equation 4, VF is composed of an ideal term (VD) and the diode series resistance (RD) multiplied by the diodes forward current (ID). The VD term dominates at low currents. Typical VF curves for diode #1 and diode #2 are shown in Figure 2 and Figure 3. These plots are typically given in diode datasheet with the forward voltage on the X axis and forward current on the Y axis.

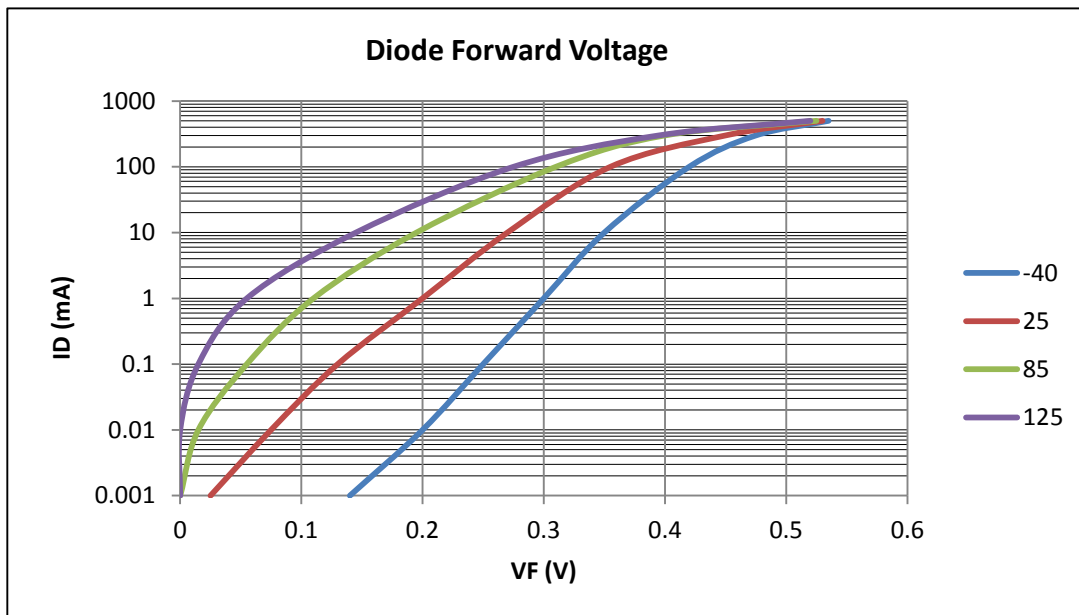

Figure 2. Diode #1 ID vs VF

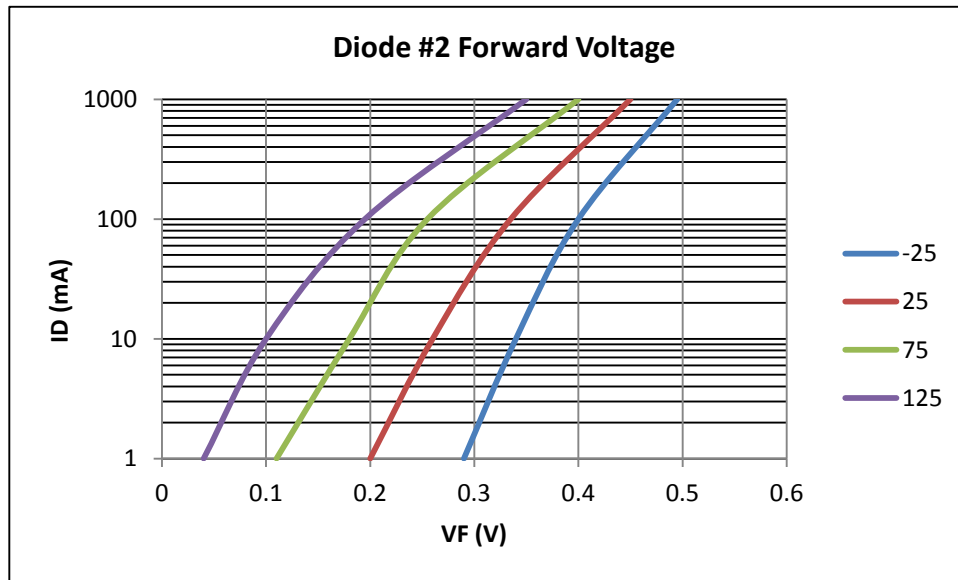

Figure 3. Diode #2 I_D vs V_F

Reversing the X and Y axis data can help reveal the diode resistance, which dominates at high currents and can therefore be calculated via the line slope (V_F/I_D). Looking at Figure 4 we can see resistance of diode #1 dominates between 100 mA and 500 mA. This has a slope at 25°C of approximately 0.42 Ω . Diode #2, on the other hand, (Figure 5) shows a much lower resistance of 0.127 Ω mainly between 100 mA and 1000 mA.

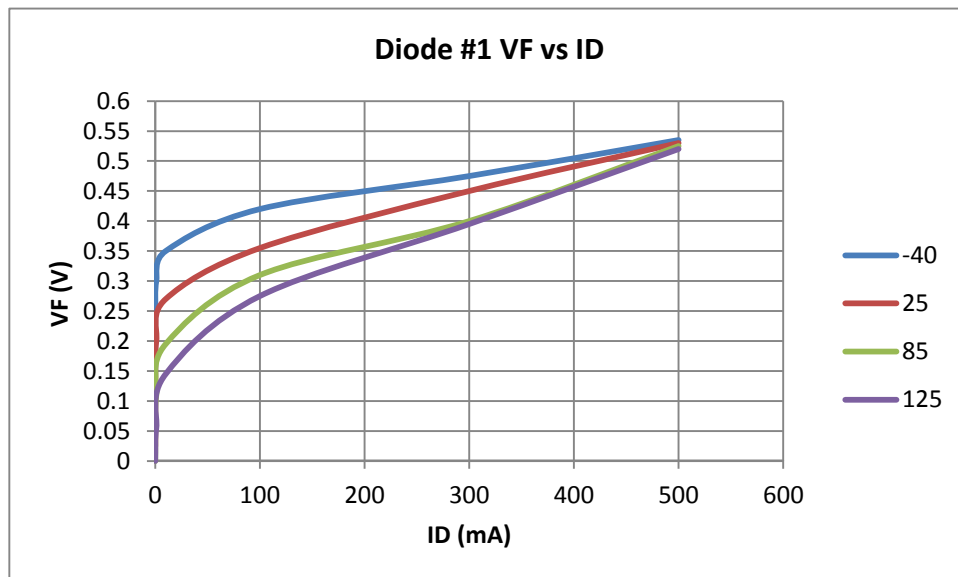

Figure 4. Diode #1 V_F vs I_D

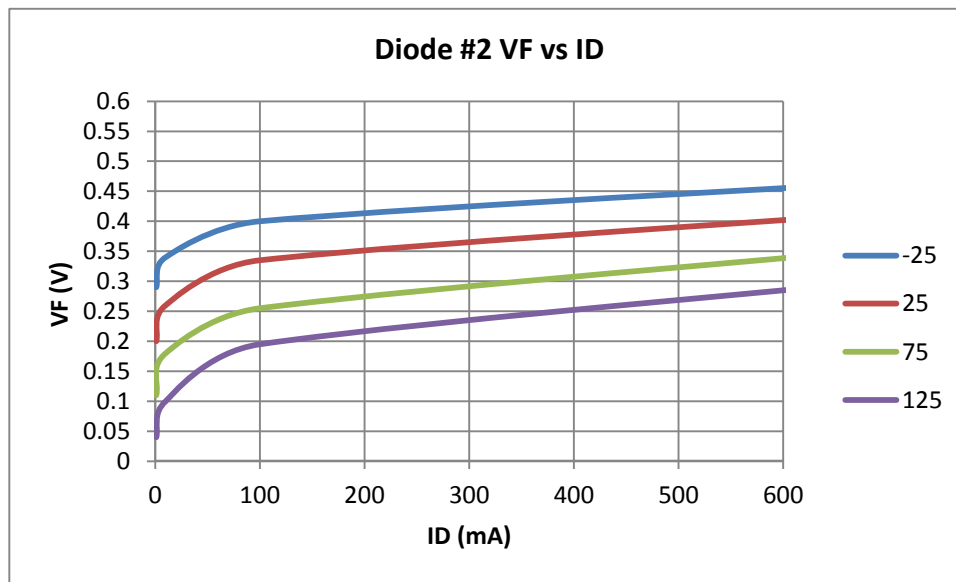

Figure 5. Diode #2 VF vs ID

2.3.2 Diode Voltage (VD)

The remaining voltage (VD) can be attributed to the diode ideal voltage ($k \times T/q \times \ln(I_D / I_S)$). In the case of diode #1 we can estimate VD from the typical 25°C (at 300 mA) curve, because we know RD. In this case we get $VD = VF - RD \times ID = 450 \text{ mV} - 0.42 \text{ } \Omega \times 300 \text{ mA} = 0.324 \text{ V}$. VD of diode #2 comes out at 0.322 V.

2.4 Diode Capacitance (CD)

Choosing a Schottky diode with a low forward-voltage drop is beneficial when the DC diode current is high. However, low VF usually means higher diode capacitance, and high capacitance effects boost efficiency more at light currents. This typically makes diode capacitance a more important parameter to keep low (than VF) when designing for LCD back light applications, as the target for optimum efficiency is normally around 5 mA to 10 mA per string.

Figure 6 and Figure 7 show typical diode capacitance curves for diode #1 and diode #2. The area under these curves represent the amount of charge (Q_D) required to take the Schottky diode from the blocking state (diode off) to the on state (diode conducting the LED current). For example, given the same reverse blocking voltage of 25 V, diode #1 shows a Q_D of approximately 135pC while diode #2 shows 8 x the charge, or approximately 1080pC. This Q_D is estimated by simply counting the number of squares under the curve from the given VR down to 0, and estimating the area ($QD = VR \times CD$).

The effective power loss due to this charging and discharging of the Schottky capacitances is approximately $f_{sw} \times Q_D \times V_{OUT}$. The V_{OUT} term happens as a result of the diode capacitance being charged from the boost output during the switch on-time when the diode is in the blocking phase.

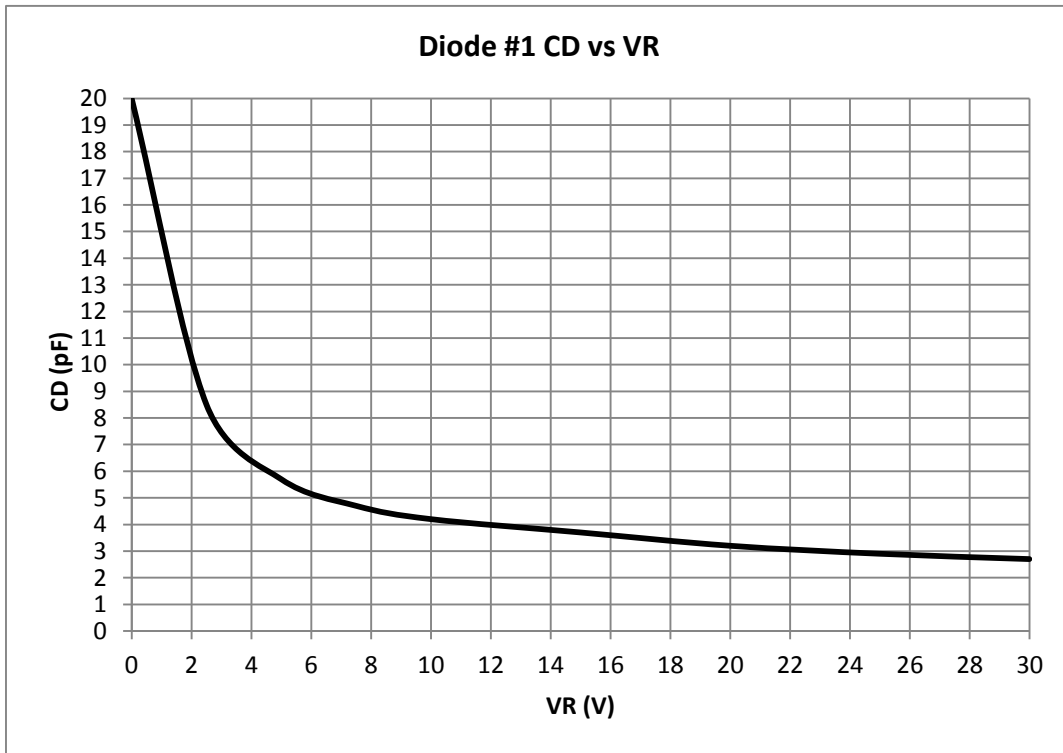

Figure 6. Diode Capacitance Curve (Diode #1)

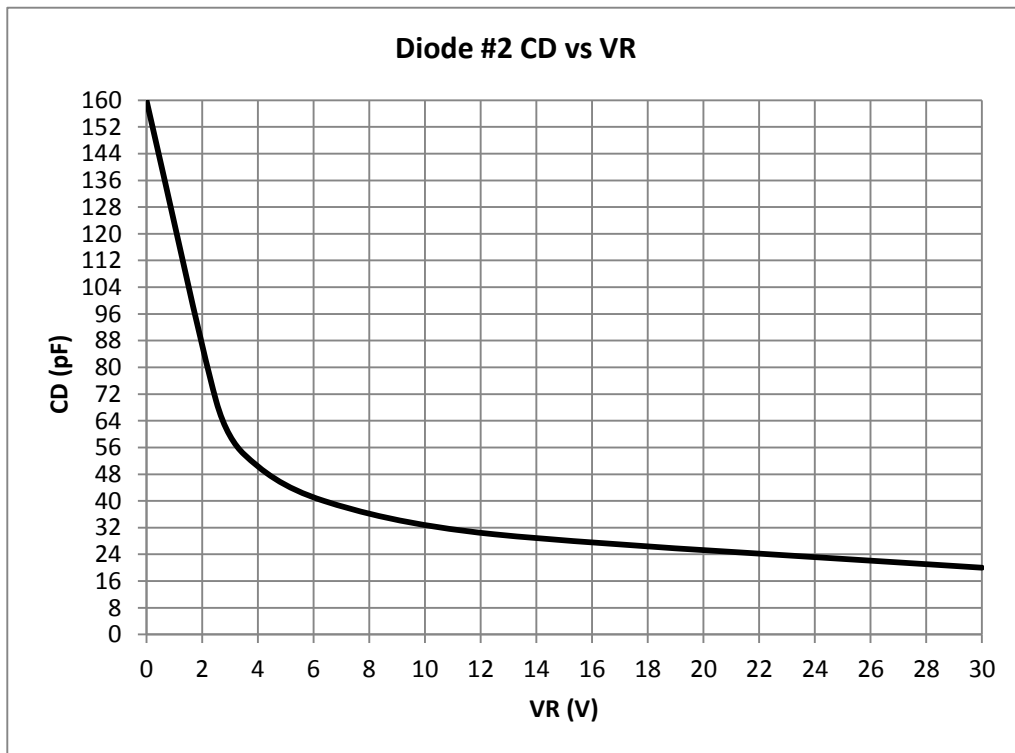

Figure 7. Diode Capacitance Curve (Diode #2)

2.5 Reverse Leakage Current (IR)

The final main parameter in Schottky diode selection is the reverse leakage current (IR). Reverse leakage current is the current from cathode to anode when the Schottky is in the blocking phase. Ideally, the leakage current should be as low as possible; however, this parameter can vary greatly between devices and has a strong positive temperature coefficient.

Figure 8, and Figure 9 shows the typical reverse current for diode #2 and diode #3 (Diode #1 was not used because its IR was approximately the same as diode #2).

Comparing the IR values at TA = 25°C and VR = 25 V, shows diode #2 with an IR = 10 µA while diode #3 has an IR = 220 µA. This IR is a direct loading on the output during the boost on-time, so we can see that going with diode #3 gives a constant load on VOUT which increases drastically with temperature.

For example, assume diode #3 were used in the LCD backlight application. VOUT = 25 V, VIN = 3.6 V, ILED = 15 mA, efficiency = 85%, and a boost duty cycle D of 0.88. The input current in this case is $15 \text{ mA} / (1 - 0.88) = 125 \text{ mA}$ and using the typical (220 µA) reverse current from diode #3, results in a $(25 \text{ V} \times 0.88 \times 220 \text{ µA}) / (3.6 \text{ V} \times 125 \text{ mA}) = 1.07\%$ efficiency loss only due to IR. Furthermore, reverse current of a typical Schottky diode increases exponentially with temperature, so a 25°C increase in diode temperature can lead to a 20× increase in leakage current. This can be a problem for small sized PCB layouts because the θ_{JA} is usually high, which results in a lot of self heating thus causing the IR to get multiple orders of magnitude higher than the 25°C levels.

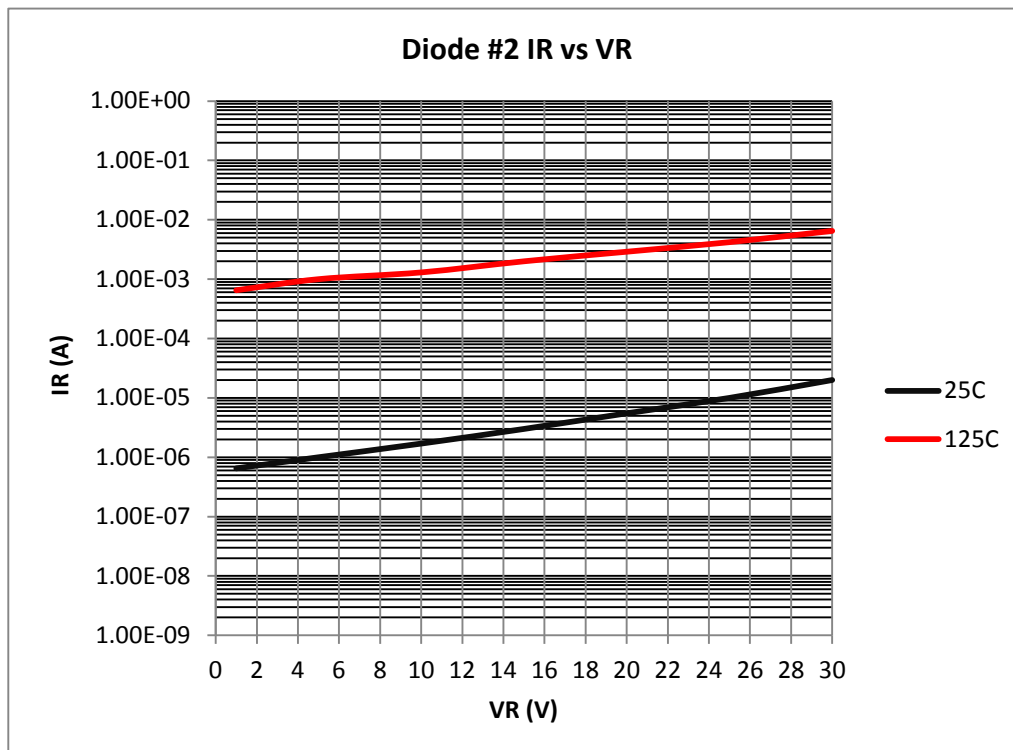

Figure 8. Reverse Leakage Current (Diode #2)

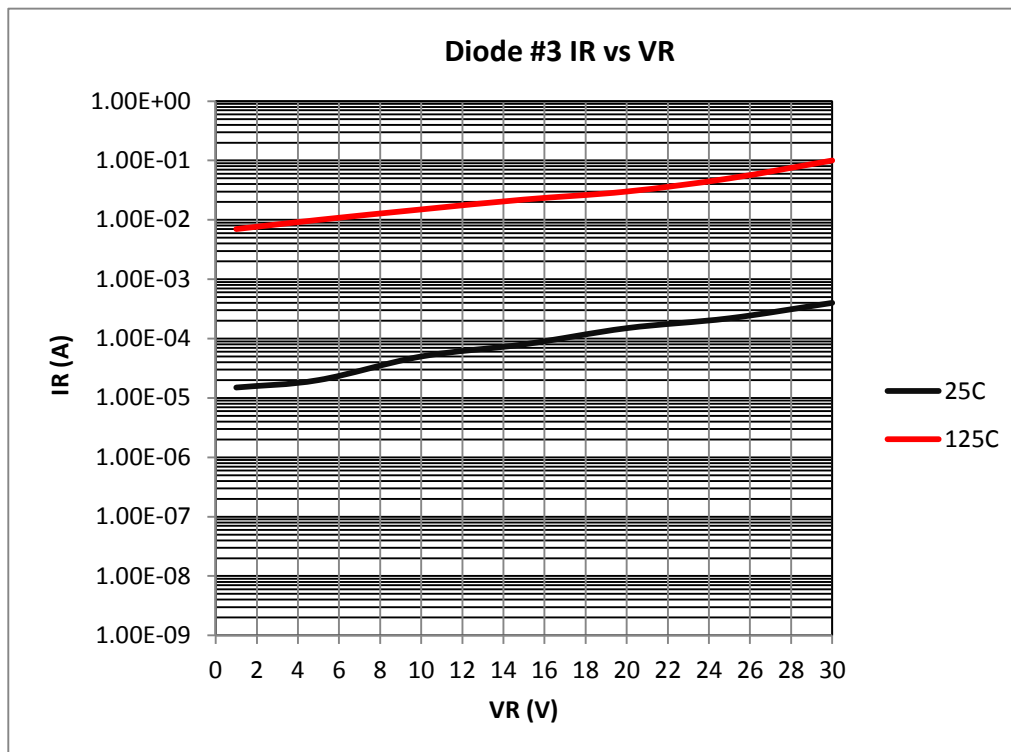

Figure 9. Reverse Leakage Current (Diode #3)

2.5.1 Thermal Runaway

A major problem with reverse current and high ambient temperatures is a condition called thermal runaway. This happens when the increasing diode temperature causes an increasing reverse current. This positive feedback between diode temperature and IR can cause the reverse current of the Schottky diode to become almost unlimited until either the diode fails, or some external circuit behavior acts to stop it (boost peak current limit, or boost thermal shutdown). Diode thermal runaway can be shown by looking at the standard equation for reverse current as a function of temperature:

$$IR = IR_0 \times (e^{c \times (T_J - T_0)}) \quad (6)$$

Equation 6 can be constructed via the typical leakage current data in a Schottky datasheet. C is given in Equation 7, and can be found using two known data points at different temperatures (using the same reverse voltage (VR)):

$$= \frac{1}{(T_{IR2} - T_{IR1})} \times LN \left(\frac{IR2}{IR1} \right) \quad (7)$$

By using the available data, Equation 6 is constructed for Diode #1 and used to plot reverse current as a function of θ_{JA} (see Figure 10). As θ_{JA} increases, the power dissipated in the diode increases due to increasing IR. We can see the thermal run-away effect happen when the reverse leakage curves go vertical. At this point the increased self heating can no longer be absorbed by the surrounding PCB and surrounding air, and the IR goes into the runaway condition. For a θ_{JA} below the runaway condition, the diode is able to reach a steady-state condition where the diodes self heating is balanced by the dissipation into the surrounding environment.

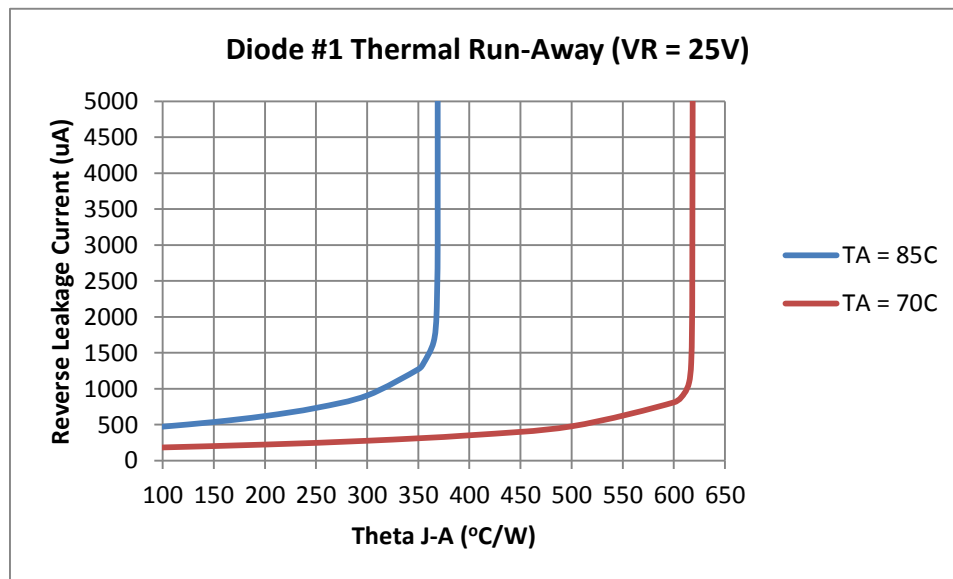

Figure 10. Thermal Runaway Condition

The Schottky diode thermal runaway problem should be looked at closely under the following conditions:

- When the diode is very small (as with diode #1 in the SOD-923 package) because θ_{JA} will generally be high;
- When the reverse leakage current at $T_A = 25^\circ\text{C}$ is $> 100 \mu\text{A}$ because IR can increase at 20x for every 25C (as with diode #3); and
- When the diode operates in high ambient temperature conditions with high average current.

3 Effects On Efficiency

Once all the Schottky parameters are understood, we can look at their effects on efficiency. Assuming the typical application circuit is used with the following conditions:

1. $V_{IN} = 3.7 \text{ V}$
2. $V_{OUT} = 25 \text{ V}$
3. $I_{LED_TOTAL} = 15 \text{ mA}$
4. $L = 10 \mu\text{H}$
5. $f_{SW} = 1 \text{ MHz}$
6. Efficiency of the boost with diode #1 = 87%
7. Efficiency of the boost with diode #2 = 82.3%
8. Input Current with diode #1 = 115.6 mA
9. Input Current with diode #1 = 122.4 mA
10. $I_{D1_RMS} = 52.2 \text{ mA}$
11. $I_{D2_RMS} = 53 \text{ mA}$
12. Duty cycle with diode #1 = 0.74
13. Duty cycle with diode #2 = 0.76

Table 2 lists the parameters for Schottky diode #1 and Schottky diode #2 .

3.1 Forward Voltage Effect on Efficiency

With VF broken down into VT and RD, their separate power losses can be calculated.

VT is simply the diode average current multiplied by the VT. With ILED_TOTAL = 15 mA, the effective power loss due to VT1 is 0.324 V × 15 mA = 4.86 mW. The effective power loss due to VT2 is basically the same at 4.83 mW

The power loss due to RD is a bit more complicated because the RMS power must be used, but to keep the calculation simple, the RMS current of the diode is given in the list above.

For diode #1, the power loss due to RD is $(0.42 \times 52.2 \text{ mA})^2 = 1.14 \text{ mW}$. For diode #2 this becomes 0.357 mW.

3.2 Diode Capacitance Effect on Efficiency

The effective QD for each diode due to the diode capacitance is given in [Table 2](#). The power loss due to this QD is again $(QD \times V_{OUT} \times f_{SW})$. Diode #1 shows an effective loss of 3.38 mW, and diode #2 shows a loss of 27 mW.

3.3 Reverse Leakage Effect on Efficiency

Finally, the loss due to IR is simply given as $V_{OUT} \times I_R \times D$. Duty cycle (D) is used because this is the percentage of the switching period that the Schottky diode is off and the reverse leakage current is conducting from VOUT, through the diode and into GND. For diode #1 the power loss due to IR is approximately (3.7 mW). For diode #3 this is 5.7 mW.

Note: If diode #3 had been used, its effective power loss due to IR at 75C would be $(3.3 \text{ mA} \times 25 \text{ V} \times 0.8 = 66 \text{ mW})$, which would have dropped the efficiency by over 10%.

[Table 2](#) lists the important parameters for diode # and diode #2. Each loss term is given as well as its weighted effect on efficiency. This is calculated by dividing the power loss by the total input power.

Table 2. Diode #1 and Diode #2 Important Parameters

	RD		VT		QD (at VR = 25 V)		IR (at VR = 25 V, TD = 75°C)	
Diode #1	0.42 Ω	1.14 mW (0.27%)	0.324 V	4.86 mW (1.14%)	135pC	3.38 mW (0.79%)	200 μA	3.7 mW (0.87%)
Diode #2	0.127 Ω	0.357 mW (0.079%)	0.322 V	4.83 mW (1.07%)	1080pC	27 mW (5.96%)	300 μA	5.7 mW (1.26 mW)

IMPORTANT NOTICE

Texas Instruments Incorporated and its subsidiaries (TI) reserve the right to make corrections, enhancements, improvements and other changes to its semiconductor products and services per JESD46, latest issue, and to discontinue any product or service per JESD48, latest issue. Buyers should obtain the latest relevant information before placing orders and should verify that such information is current and complete. All semiconductor products (also referred to herein as "components") are sold subject to TI's terms and conditions of sale supplied at the time of order acknowledgment.

TI warrants performance of its components to the specifications applicable at the time of sale, in accordance with the warranty in TI's terms and conditions of sale of semiconductor products. Testing and other quality control techniques are used to the extent TI deems necessary to support this warranty. Except where mandated by applicable law, testing of all parameters of each component is not necessarily performed.

TI assumes no liability for applications assistance or the design of Buyers' products. Buyers are responsible for their products and applications using TI components. To minimize the risks associated with Buyers' products and applications, Buyers should provide adequate design and operating safeguards.

TI does not warrant or represent that any license, either express or implied, is granted under any patent right, copyright, mask work right, or other intellectual property right relating to any combination, machine, or process in which TI components or services are used. Information published by TI regarding third-party products or services does not constitute a license to use such products or services or a warranty or endorsement thereof. Use of such information may require a license from a third party under the patents or other intellectual property of the third party, or a license from TI under the patents or other intellectual property of TI.

Reproduction of significant portions of TI information in TI data books or data sheets is permissible only if reproduction is without alteration and is accompanied by all associated warranties, conditions, limitations, and notices. TI is not responsible or liable for such altered documentation. Information of third parties may be subject to additional restrictions.

Resale of TI components or services with statements different from or beyond the parameters stated by TI for that component or service voids all express and any implied warranties for the associated TI component or service and is an unfair and deceptive business practice. TI is not responsible or liable for any such statements.

Buyer acknowledges and agrees that it is solely responsible for compliance with all legal, regulatory and safety-related requirements concerning its products, and any use of TI components in its applications, notwithstanding any applications-related information or support that may be provided by TI. Buyer represents and agrees that it has all the necessary expertise to create and implement safeguards which anticipate dangerous consequences of failures, monitor failures and their consequences, lessen the likelihood of failures that might cause harm and take appropriate remedial actions. Buyer will fully indemnify TI and its representatives against any damages arising out of the use of any TI components in safety-critical applications.

In some cases, TI components may be promoted specifically to facilitate safety-related applications. With such components, TI's goal is to help enable customers to design and create their own end-product solutions that meet applicable functional safety standards and requirements. Nonetheless, such components are subject to these terms.

No TI components are authorized for use in FDA Class III (or similar life-critical medical equipment) unless authorized officers of the parties have executed a special agreement specifically governing such use.

Only those TI components which TI has specifically designated as military grade or "enhanced plastic" are designed and intended for use in military/aerospace applications or environments. Buyer acknowledges and agrees that any military or aerospace use of TI components which have **not** been so designated is solely at the Buyer's risk, and that Buyer is solely responsible for compliance with all legal and regulatory requirements in connection with such use.

TI has specifically designated certain components as meeting ISO/TS16949 requirements, mainly for automotive use. In any case of use of non-designated products, TI will not be responsible for any failure to meet ISO/TS16949.

Products

Audio	www.ti.com/audio
Amplifiers	amplifier.ti.com
Data Converters	dataconverter.ti.com
DLP® Products	www.dlp.com
DSP	dsp.ti.com
Clocks and Timers	www.ti.com/clocks
Interface	interface.ti.com
Logic	logic.ti.com
Power Mgmt	power.ti.com
Microcontrollers	microcontroller.ti.com
RFID	www.ti-rfid.com
OMAP Applications Processors	www.ti.com/omap
Wireless Connectivity	www.ti.com/wirelessconnectivity

Applications

Automotive and Transportation	www.ti.com/automotive
Communications and Telecom	www.ti.com/communications
Computers and Peripherals	www.ti.com/computers
Consumer Electronics	www.ti.com/consumer-apps
Energy and Lighting	www.ti.com/energy
Industrial	www.ti.com/industrial
Medical	www.ti.com/medical
Security	www.ti.com/security
Space, Avionics and Defense	www.ti.com/space-avionics-defense
Video and Imaging	www.ti.com/video

TI E2E Community

e2e.ti.com