

LM74700-Q1 Low I_Q Reverse Battery Protection Ideal Diode Controller

1 Features

- AEC-Q100 qualified with the following results
 - Device temperature grade 1: –40°C to +125°C ambient operating temperature range
 - Device HBM ESD classification level 2
 - Device CDM ESD classification level C4B
- **Functional Safety-Capable**
 - [Documentation available to aid functional safety system design](#)
- 3.2-V to 65-V input range (3.9-V start up)
- –65-V reverse voltage rating
- Charge pump for external N-Channel MOSFET
- 20-mV ANODE to CATHODE forward voltage drop regulation
- Enable pin feature
- 1-μA shutdown current (EN=Low)
- 80-μA operating quiescent current (EN=High)
- 2.3-A peak gate turnoff current
- Fast response to reverse current blocking: < 0.75 μs
- Meets automotive ISO7637 transient requirements with a suitable TVS Diode
- Available in 6-pin and 8-pin SOT-23 Package 2.90 mm × 1.60 mm

2 Applications

- Automotive ADAS systems - camera
- Automotive infotainment systems - digital cluster, head unit
- Industrial factory automation - PLC
- Enterprise power supplies
- Active ORing for redundant power

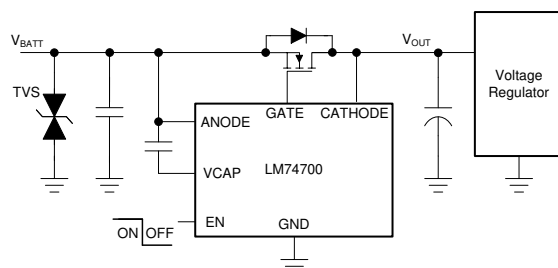

Typical Application Schematic

3 Description

The LM74700-Q1 is an automotive AEC Q100 qualified ideal diode controller which operates in conjunction with an external N-channel MOSFET as an ideal diode rectifier for low loss reverse polarity protection with a 20-mV forward voltage drop. The wide supply input range of 3.2 V to 65 V allows control of many popular DC bus voltages such as 12-V, 24-V and 48-V automotive battery systems. The 3.2-V input voltage support is particularly well suited for severe cold crank requirements in automotive systems. The device can withstand and protect the loads from negative supply voltages down to –65 V.

The device controls the GATE of the MOSFET to regulate the forward voltage drop at 20 mV. The regulation scheme enables graceful turn off of the MOSFET during a reverse current event and ensures zero DC reverse current flow. Fast response (< 0.75 μs) to Reverse Current Blocking makes the device suitable for systems with output voltage holdup requirements during ISO7637 pulse testing as well as power fail and input micro-short conditions.

The LM74700-Q1 controller provides a charge pump gate drive for an external N-channel MOSFET. The high voltage rating of LM74700-Q1 helps to simplify the system designs for automotive ISO7637 protection. With the enable pin low, the controller is off and draws approximately 1 μA of current.

Device Information (1)

| PART NUMBER | PACKAGE | BODY SIZE (NOM) |
|-------------|------------|-------------------|
| LM74700-Q1 | SOT-23 (6) | 2.90 mm × 1.60 mm |
| LM74700-Q1 | SOT-23 (8) | 2.90 mm × 1.60 mm |

(1) For all available packages, see the orderable addendum at the end of the data sheet.

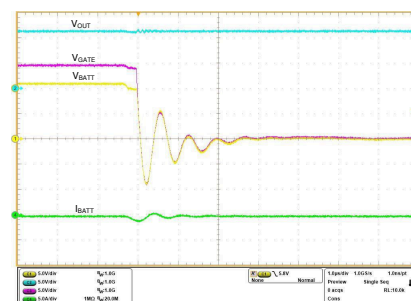

Reverse Current Blocking During Input Short



Table of Contents

| | | | |
|--|----|--|----|
| 1 Features | 1 | 9.3 Feature Description..... | 13 |
| 2 Applications | 1 | 9.4 Device Functional Modes..... | 15 |
| 3 Description | 1 | 10 Application and Implementation | 16 |
| 4 Revision History | 2 | 10.1 Application Information..... | 16 |
| 5 Pin Configuration and Functions | 3 | 10.2 OR-ing Application Configuration..... | 22 |
| 6 Specifications | 5 | 11 Power Supply Recommendations | 22 |
| 6.1 Absolute Maximum Ratings..... | 5 | 12 Layout | 23 |
| 6.2 ESD Ratings..... | 5 | 12.1 Layout Guidelines..... | 23 |
| 6.3 Recommended Operating Conditions..... | 5 | 12.2 Layout Example..... | 24 |
| 6.4 Thermal Information..... | 6 | 13 Device and Documentation Support | 25 |
| 6.5 Electrical Characteristics..... | 6 | 13.1 Receiving Notification of Documentation Updates..... | 25 |
| 6.6 Switching Characteristics..... | 7 | 13.2 Support Resources..... | 25 |
| 7 Typical Characteristics | 8 | 13.3 Trademarks..... | 25 |
| 8 Parameter Measurement Information | 11 | 13.4 Electrostatic Discharge Caution..... | 25 |
| 9 Detailed Description | 12 | 13.5 Glossary..... | 25 |
| 9.1 Overview..... | 12 | 14 Mechanical, Packaging, and Orderable Information | 25 |
| 9.2 Functional Block Diagram..... | 12 | | |

4 Revision History

NOTE: Page numbers for previous revisions may differ from page numbers in the current version.

| Changes from Revision F (December 2019) to Revision G (December 2020) | Page |
|---|-------------|
| • Updated the numbering format for tables, figures and cross-references throughout the document..... | 1 |
| • Added DDF (SOT-23) package option to data sheet..... | 1 |
| • Relaxed VCAP specs in <i>Electrical Characteristics</i> table..... | 5 |
| Changes from Revision E (February 2019) to Revision F (December 2019) | Page |
| • Added the Functional safety capable link to the <i>Features</i> section..... | 1 |
| Changes from Revision D (January 2019) to Revision E (February 2019) | Page |
| • Changed from Advance Information to Production Data | 1 |
| Changes from Revision C (November 2018) to Revision D (January 2019) | Page |
| • Added <i>Typical Characteristics</i> section | 8 |
| • Added <i>Parameter Measurement Information</i> section | 11 |
| • Deleted <i>Application Limitations</i> section | 22 |
| • Added <i>Or-ing Application Configuration</i> section | 22 |
| Changes from Revision B (October 2018) to Revision C (November 2018) | Page |
| • Added footnotes to the <i>Absolute Maximum Ratings</i> and <i>Recommended Operating Conditions</i> tables in the <i>Specifications</i> section..... | 5 |
| Changes from Revision A (March 2018) to Revision B (October 2018) | Page |
| • Changes made in the <i>Specifications</i> and <i>Application Limitations</i> sections..... | 1 |
| Changes from Revision * (October 2017) to Revision A (March 2018) | Page |
| • Multiple changes made throughout Data Sheet..... | 1 |

5 Pin Configuration and Functions

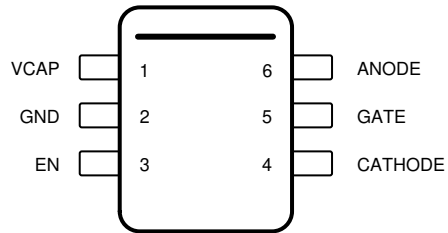

Figure 5-1. DBV Package 6-Pin SOT-23 Top View

Table 5-1. Pin Functions

| PIN | | I/O ⁽¹⁾ | DESCRIPTION |
|-----|---------|--------------------|--|
| NO. | NAME | | |
| 1 | VCAP | O | Charge pump output. Connect to external charge pump capacitor |
| 2 | GND | G | Ground pin |
| 3 | EN | I | Enable pin. Can be connected to ANODE for always ON operation |
| 4 | CATHODE | I | Cathode of the diode. Connect to the drain of the external N-channel MOSFET |
| 5 | GATE | O | Gate drive output. Connect to gate of the external N-channel MOSFET |
| 6 | ANODE | I | Anode of the diode and input power. Connect to the source of the external N-channel MOSFET |

(1) I = Input, O = Output, G = GND

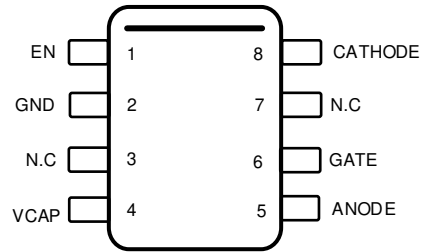

Figure 5-2. DDF Package 8-Pin SOT-23 Top View

Table 5-2. Pin Functions

| PIN | | I/O ⁽¹⁾ | DESCRIPTION |
|-----|---------|--------------------|--|
| NO. | NAME | | |
| 1 | EN | I | Enable pin. Can be connected to ANODE for always ON operation |
| 2 | GND | G | Ground pin |
| 3 | N.C | | No connection |
| 4 | VCAP | O | Charge pump output. Connect to external charge pump capacitor |
| 5 | ANODE | I | Anode of the diode and input power. Connect to the source of the external N-channel MOSFET |
| 6 | GATE | O | Gate drive output. Connect to gate of the external N-channel MOSFET |
| 7 | N.C | | No connection |
| 8 | CATHODE | I | Cathode of the diode. Connect to the drain of the external N-channel MOSFET |

(1) I = Input, O = Output, G = GND

6 Specifications

6.1 Absolute Maximum Ratings

over operating free-air temperature range (unless otherwise noted)⁽¹⁾

| | | MIN | MAX | UNIT |
|---|-----------------------------------|---------------|----------------------|------|
| Input Pins | ANODE to GND | -65 | 65 | V |
| | EN to GND, $V_{(ANODE)} > 0$ V | -0.3 | 65 | V |
| | EN to GND, $V_{(ANODE)} \leq 0$ V | $V_{(ANODE)}$ | $(65 + V_{(ANODE)})$ | V |
| Output Pins | GATE to ANODE | -0.3 | 15 | V |
| | VCAP to ANODE | -0.3 | 15 | V |
| Output to Input Pins | CATHODE to ANODE | -5 | 75 | V |
| Operating junction temperature ⁽²⁾ | | -40 | 150 | °C |
| Storage temperature, T_{stg} | | -40 | 150 | °C |

- (1) Stresses beyond those listed under Absolute Maximum Ratings may cause permanent damage to the device. These are stress ratings only, which do not imply functional operation of the device at these or any other conditions beyond those indicated under Recommended Operating Conditions. Exposure to absolute-maximum-rated conditions for extended periods may affect device reliability.
- (2) High junction temperatures degrade operating lifetimes. Operating lifetime is de-rated for junction temperatures greater than 125°C.

6.2 ESD Ratings

| | | | VALUE | UNIT | |
|-------------|-------------------------|---|--|------|------|
| $V_{(ESD)}$ | Electrostatic discharge | Human body model (HBM), per AEC Q100-002 ⁽¹⁾ | ±2000 | V | |
| | | Charged device model (CDM), per AEC Q100-011 | Corner pins (VCAP, EN, ANODE, CATHODE) | | ±750 |
| | | | Other pins | | ±500 |

- (1) JEDEC document JEP155 states that 500-V HBM allows safe manufacturing with a standard ESD control process.

6.3 Recommended Operating Conditions

over operating free-air temperature range (unless otherwise noted)⁽¹⁾

| | | MIN | NOM | MAX | UNIT |
|-------------------------------------|---|-----|-----|-----|------|
| Input Pins | ANODE to GND | -60 | | 60 | V |
| | CATHODE to GND | | | 60 | |
| | EN to GND | -60 | | 60 | |
| Input to Output pins | ANODE to CATHODE | -70 | | | V |
| External capacitance | ANODE | 22 | | | nF |
| | CATHODE, VCAP to ANODE | 0.1 | | | µF |
| External MOSFET max V_{GS} rating | GATE to ANODE | 15 | | | V |
| T_J | Operating junction temperature range ⁽²⁾ | -40 | | 150 | °C |

- (1) Recommended Operating Conditions are conditions under which the device is intended to be functional. For specifications and test conditions, see [Electrical Characteristics](#).
- (2) High junction temperatures degrade operating lifetimes. Operating lifetime is de-rated for junction temperatures greater than 125°C.

6.4 Thermal Information

| THERMAL METRIC ⁽¹⁾ | | LM74700-Q1 | LM74700-Q1 | UNIT |
|-------------------------------|--|------------|------------|------|
| | | DBV (SOT) | DDF (SOT) | |
| | | 6 PINS | 8 PINS | |
| R _{θJA} | Junction-to-ambient thermal resistance | 189.8 | 133.8 | °C/W |
| R _{θJC(top)} | Junction-to-case (top) thermal resistance | 103.8 | 72.6 | °C/W |
| R _{θJB} | Junction-to-board thermal resistance | 45.8 | 54.5 | °C/W |
| Ψ _{JT} | Junction-to-top characterization parameter | 19.4 | 4.6 | °C/W |
| Ψ _{JB} | Junction-to-board characterization parameter | 45.5 | 54.2 | °C/W |

(1) For more information about traditional and new thermal metrics, see the Semiconductor and IC Package Thermal Metrics application report, SPRA953.

6.5 Electrical Characteristics

T_J = -40°C to +125°C; typical values at T_J = 25°C, V_(ANODE) = 12 V, C_(VCAP) = 0.1 μF, V_(EN) = 3.3 V, over operating free-air temperature range (unless otherwise noted)

| PARAMETER | | TEST CONDITIONS | MIN | TYP | MAX | UNIT |
|---|--|--|------|------|------|------|
| V_{ANODE} SUPPLY VOLTAGE | | | | | | |
| V _(ANODE) | Operating input voltage | | 4 | | 60 | V |
| V _(ANODE POR) | VANODE POR Rising threshold | | | | 3.9 | V |
| | VANODE POR Falling threshold | | 2.2 | 2.8 | 3.1 | V |
| V _{(ANODE POR(Hys))} | VANODE POR Hysteresis | | 0.44 | | 0.67 | V |
| I _(SHDN) | Shutdown Supply Current | V _(EN) = 0 V | | 0.9 | 1.5 | μA |
| I _(Q) | Operating Quiescent Current | | | 80 | 130 | μA |
| ENABLE INPUT | | | | | | |
| V _(EN_IL) | Enable input low threshold | | 0.5 | 0.9 | 1.22 | V |
| V _(EN_IH) | Enable input high threshold | | 1.06 | 2 | 2.6 | |
| V _(EN_Hys) | Enable Hysteresis | | 0.52 | | 1.35 | V |
| I _(EN) | Enable sink current | V _(EN) = 12 V | | 3 | 5 | μA |
| V_{ANODE} to V_{CATHODE} | | | | | | |
| V _(AK REG) | Regulated Forward V _(AK) Threshold | | 13 | 20 | 29 | mV |
| V _(AK) | V _(AK) threshold for full conduction mode | | 34 | 50 | 57 | mV |
| V _(AK REV) | V _(AK) threshold for reverse current blocking | | -17 | -11 | -2 | mV |
| G _m | Regulation Error AMP Transconductance ⁽¹⁾ | | 1200 | 1800 | 3100 | μA/V |
| GATE DRIVE | | | | | | |
| I _(GATE) | Peak source current | V _(ANODE) - V _(CATHODE) = 100 mV, V _(GATE) - V _(ANODE) = 5 V | 3 | 11 | | mA |
| | Peak sink current | V _(ANODE) - V _(CATHODE) = -20 mV, V _(GATE) - V _(ANODE) = 5 V | | 2370 | | mA |
| | Regulation max sink current | V _(ANODE) - V _(CATHODE) = 0 V, V _(GATE) - V _(ANODE) = 5 V | 6 | 26 | | μA |
| RDS _{ON} | discharge switch RDS _{ON} | V _(ANODE) - V _(CATHODE) = -20 mV, V _(GATE) - V _(ANODE) = 100 mV | 0.4 | | 2 | Ω |
| CHARGE PUMP | | | | | | |

6.5 Electrical Characteristics (continued)

$T_J = -40^{\circ}\text{C}$ to $+125^{\circ}\text{C}$; typical values at $T_J = 25^{\circ}\text{C}$, $V_{(ANODE)} = 12\text{ V}$, $C_{(VCAP)} = 0.1\ \mu\text{F}$, $V_{(EN)} = 3.3\text{ V}$, over operating free-air temperature range (unless otherwise noted)

| PARAMETER | | TEST CONDITIONS | MIN | TYP | MAX | UNIT |
|----------------------------|---|--|------|------|------|---------------|
| $I_{(VCAP)}$ | Charge Pump source current (Charge pump on) | $V_{(VCAP)} - V_{(ANODE)} = 7\text{ V}$ | 162 | 300 | 600 | μA |
| | Charge Pump sink current (Charge pump off) | $V_{(VCAP)} - V_{(ANODE)} = 14\text{ V}$ | | 5 | 10 | μA |
| $V_{(VCAP)} - V_{(ANODE)}$ | Charge pump voltage at $V_{(ANODE)} = 3.2\text{ V}$ | $I_{(VCAP)} \leq 30\ \mu\text{A}$ | 8 | | | V |
| | Charge pump turn on voltage | | 10.8 | 12.1 | 12.9 | V |
| | Charge pump turn off voltage | | 11.6 | 13 | 13.9 | V |
| | Charge Pump Enable comparator Hysteresis | | 0.54 | 0.9 | 1.36 | V |
| $V_{(VCAP\ UVLO)}$ | $V_{(VCAP)} - V_{(ANODE)}$ UV release at rising edge | $V_{(ANODE)} - V_{(CATHODE)} = 100\text{ mV}$ | 5.8 | 6.6 | 7.7 | V |
| | $V_{(VCAP)} - V_{(ANODE)}$ UV threshold at falling edge | $V_{(ANODE)} - V_{(CATHODE)} = 100\text{ mV}$ | 5.11 | 5.68 | 6 | V |
| CATHODE | | | | | | |
| $I_{(CATHODE)}$ | CATHODE sink current | $V_{(ANODE)} = 12\text{ V}$, $V_{(ANODE)} - V_{(CATHODE)} = -100\text{ mV}$ | | 1.7 | 2 | μA |
| | | $V_{(ANODE)} - V_{(CATHODE)} = -100\text{ mV}$ | | 1.2 | 2.2 | μA |
| | | $V_{(ANODE)} = -12\text{ V}$, $V_{(CATHODE)} = 12\text{ V}$ | | 1.25 | 2.06 | μA |

(1) Parameter guaranteed by design and characterization

6.6 Switching Characteristics

$T_J = -40^{\circ}\text{C}$ to $+125^{\circ}\text{C}$; typical values at $T_J = 25^{\circ}\text{C}$, $V_{(ANODE)} = 12\text{ V}$, $C_{(VCAP)} = 0.1\ \mu\text{F}$, $V_{(EN)} = 3.3\text{ V}$, over operating free-air temperature range (unless otherwise noted)

| PARAMETER | | TEST CONDITIONS | MIN | TYP | MAX | UNIT |
|-------------------------------|--|---|-----|------|------|---------------|
| EN_{TDLY} | Enable (low to high) to Gate Turn On delay | $V_{(VCAP)} > V_{(VCAP\ UVLOR)}$ | | 75 | 110 | μs |
| $t_{\text{Reverse delay}}$ | Reverse voltage detection to Gate Turn Off delay | $V_{(ANODE)} - V_{(CATHODE)} = 100\text{ mV}$ to -100 mV | | 0.45 | 0.75 | μs |
| $t_{\text{Forward recovery}}$ | Forward voltage detection to Gate Turn On delay | $V_{(ANODE)} - V_{(CATHODE)} = -100\text{ mV}$ to 700 mV | | 1.4 | 2.6 | μs |

7 Typical Characteristics

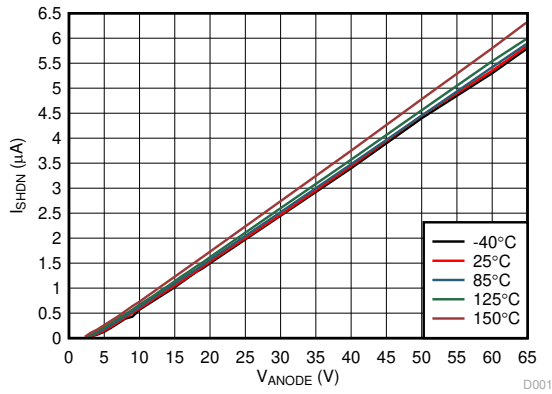

Figure 7-1. Shutdown Supply Current vs Supply Voltage

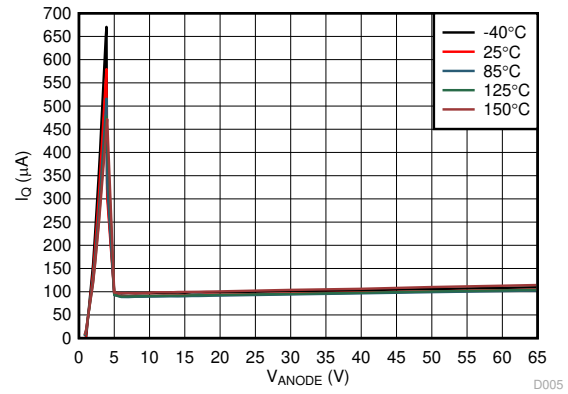

Figure 7-2. Operating Quiescent Current vs Supply Voltage

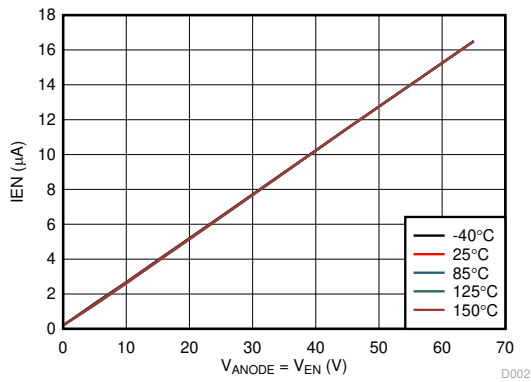

Figure 7-3. Enable Sink Current vs Supply Voltage

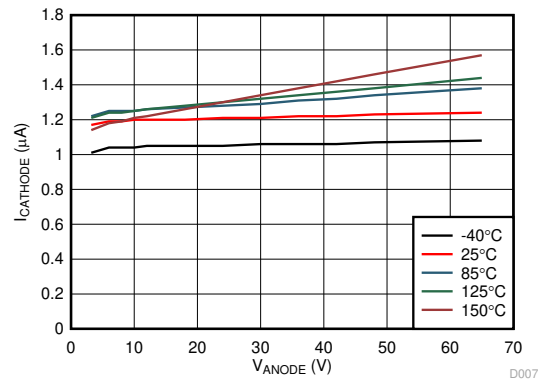

Figure 7-4. CATHODE Sink Current vs Supply Voltage

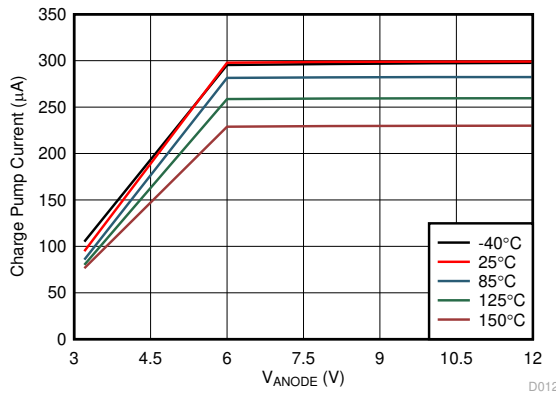

Figure 7-5. Charge Pump Current vs Supply Voltage at $V_{CAP} = 6\text{ V}$

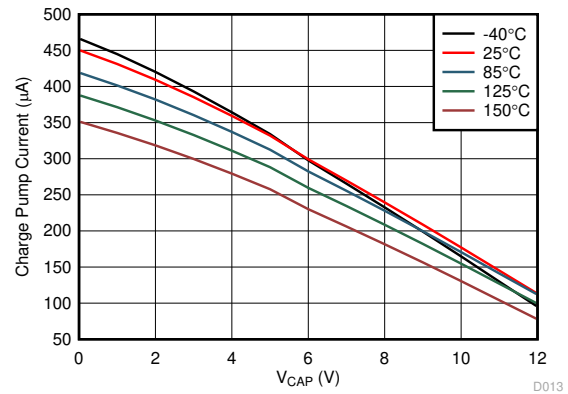

Figure 7-6. Charge Pump V-I Characteristics at $V_{ANODE} \geq 12\text{ V}$

7 Typical Characteristics (continued)

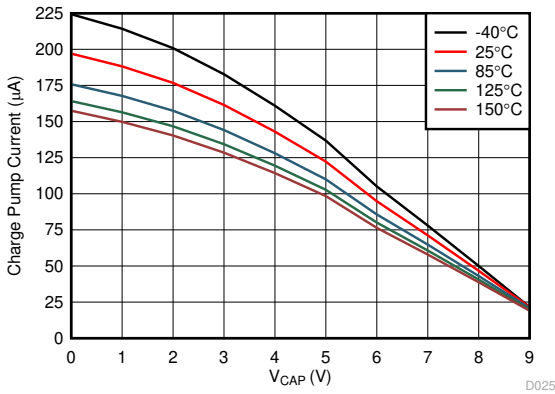

Figure 7-7. Charge Pump V-I Characteristics at VANODE = 3.2 V

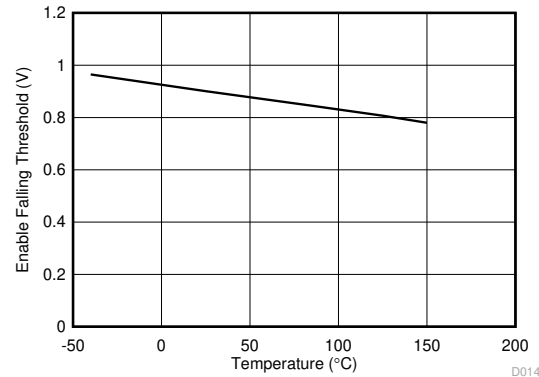

Figure 7-8. Enable Falling Threshold vs Temperature

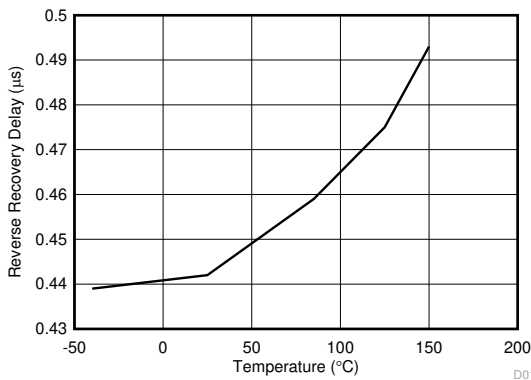

Figure 7-9. Reverse Current Blocking Delay vs Temperature

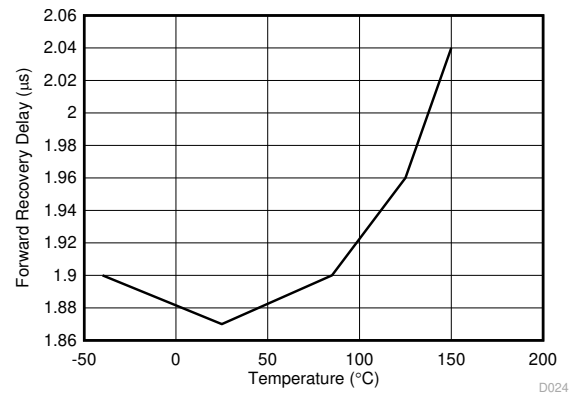

Figure 7-10. Forward Recovery Delay vs Temperature

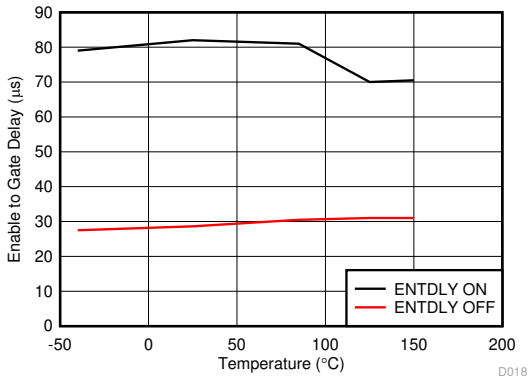

Figure 7-11. Enable to Gate Delay vs Temperature

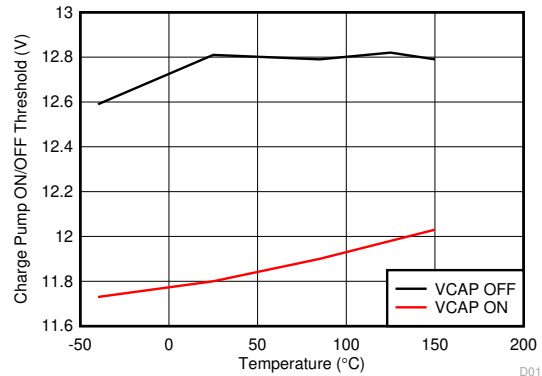

Figure 7-12. Charge Pump ON/OFF Threshold vs Temperature

7 Typical Characteristics (continued)

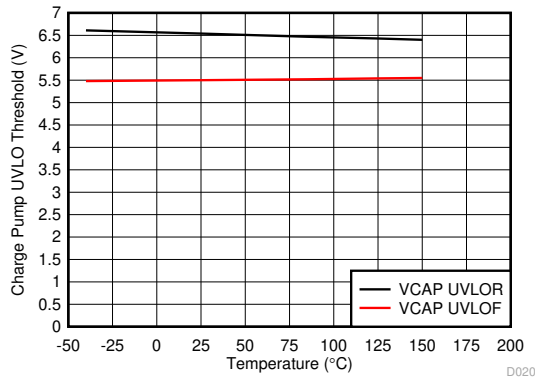

Figure 7-13. Charge Pump UVLO Threshold vs Temperature

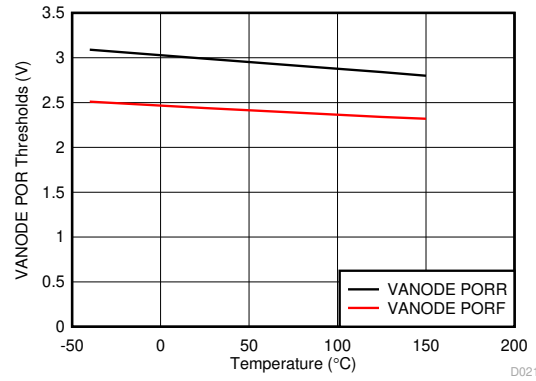

Figure 7-14. VANODE POR Threshold vs Temperature

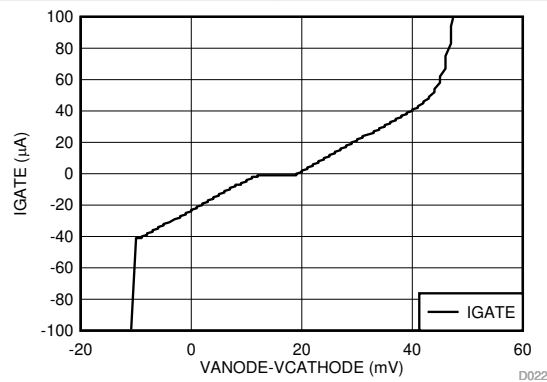

Figure 7-15. Gate Current vs Forward Voltage Drop

8 Parameter Measurement Information

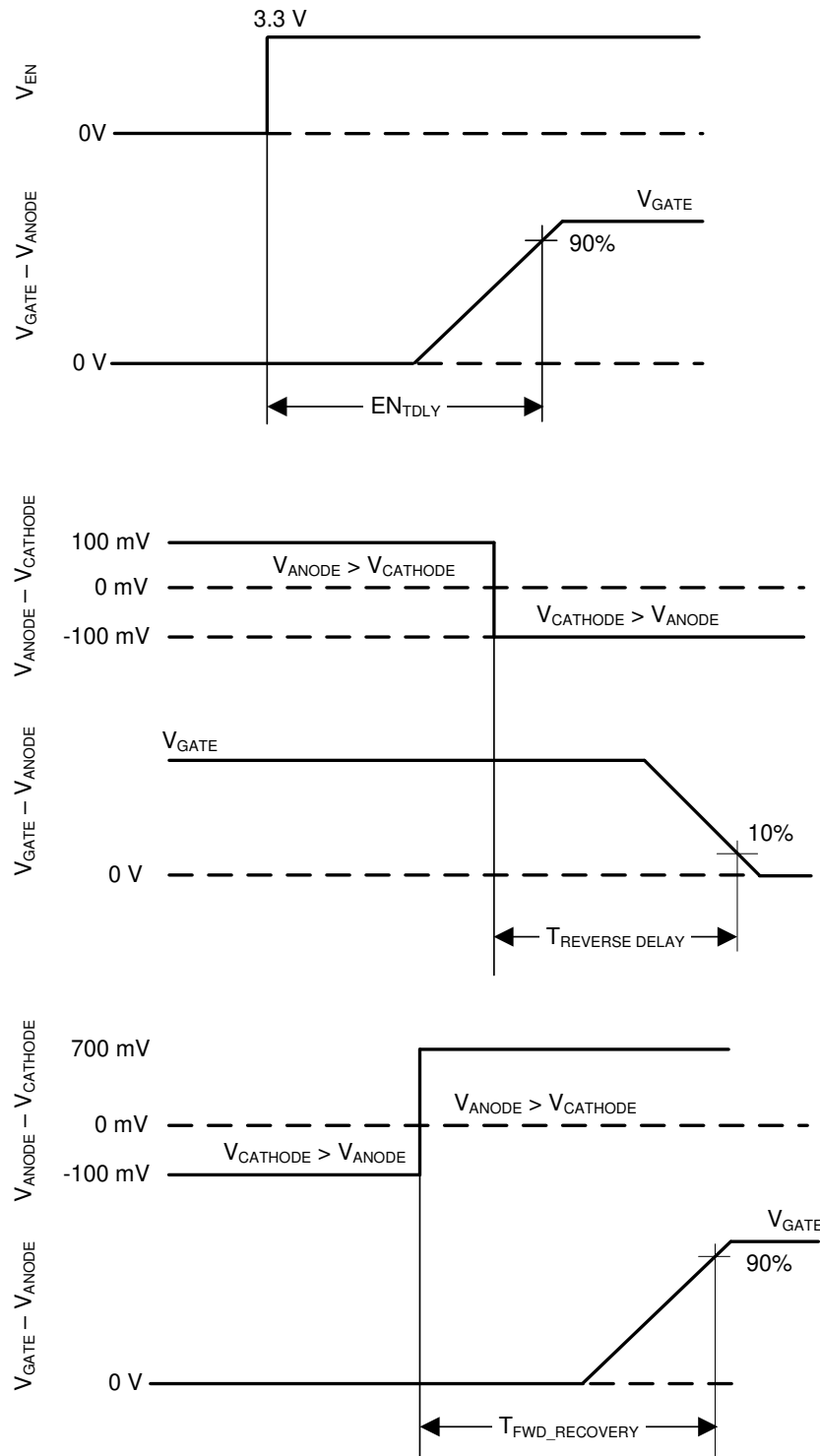

Figure 8-1. Timing Waveforms

9 Detailed Description

9.1 Overview

The LM74700-Q1 [ideal diode controller](#) has all the features necessary to implement an efficient and fast reverse polarity protection circuit or be used in an ORing configuration while minimizing the number of external components. This easy to use ideal diode controller is paired with an external N-channel MOSFET to replace other reverse polarity schemes such as a P-channel MOSFET or a Schottky diode. An internal charge pump is used to drive the external N-Channel MOSFET to a maximum gate drive voltage of approximately 15 V. The voltage drop across the MOSFET is continuously monitored between the ANODE and CATHODE pins, and the GATE to ANODE voltage is adjusted as needed to regulate the forward voltage drop at 20 mV. This closed loop regulation scheme enables graceful turn off of the MOSFET during a reverse current event and ensures zero DC reverse current flow. A fast reverse current condition is detected when the voltage across ANODE and CATHODE pins reduces below -11 mV , resulting in the GATE pin being internally connected to the ANODE pin turning off the external N-channel MOSFET, and using the body diode to block any of the reverse current. An enable pin, EN is available to place the LM74700-Q1 in shutdown mode disabling the N-Channel MOSFET and minimizing the quiescent current.

9.2 Functional Block Diagram

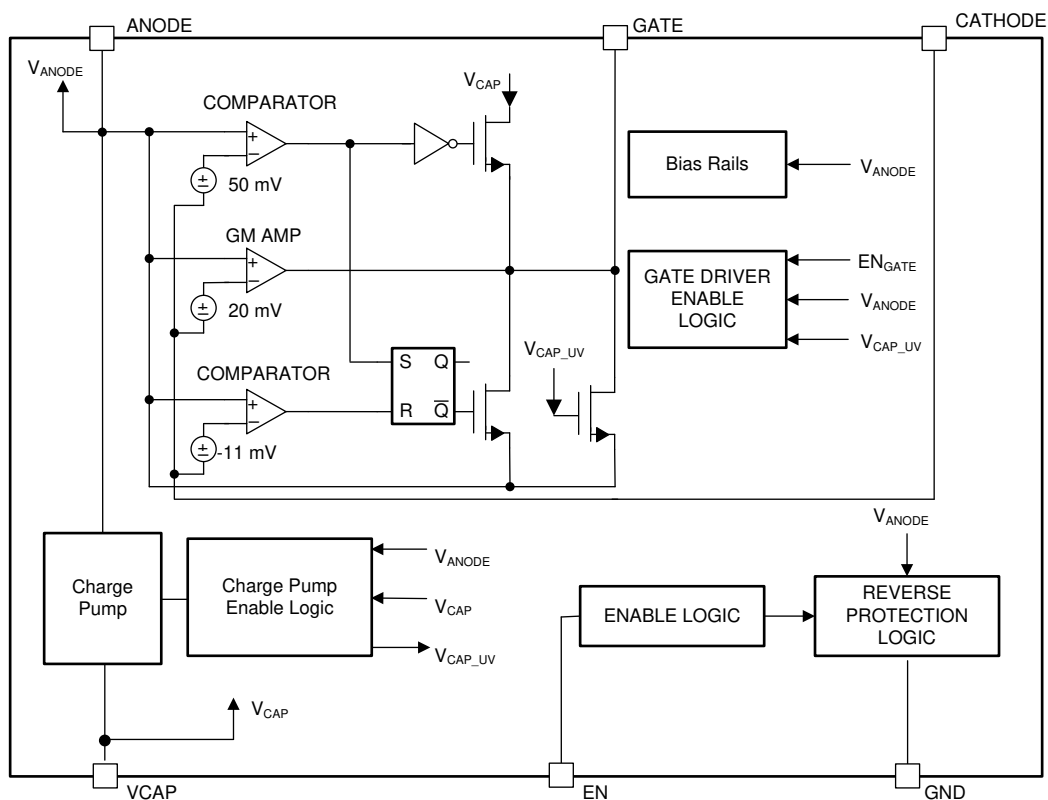

Copyright © 2017, Texas Instruments Incorporated

9.3 Feature Description

9.3.1 Input Voltage

The ANODE pin is used to power the LM74700-Q1's internal circuitry, typically drawing 80 μA when enabled and 1 μA when disabled. If the ANODE pin voltage is greater than the POR Rising threshold, then LM74700-Q1 operates in either shutdown mode or conduction mode in accordance with the EN pin voltage. The voltage from ANODE to GND is designed to vary from 65 V to -65 V, allowing the LM74700-Q1 to withstand negative voltage transients.

9.3.2 Charge Pump

The charge pump supplies the voltage necessary to drive the external N-channel MOSFET. An external charge pump capacitor is placed between VCAP and ANODE pins to provide energy to turn on the external MOSFET. In order for the charge pump to supply current to the external capacitor the EN pin voltage must be above the specified input high threshold, $V_{(EN_IH)}$. When enabled the charge pump sources a charging current of 300- μA typical. If EN pins is pulled low, then the charge pump remains disabled. To ensure that the external MOSFET can be driven above its specified threshold voltage, the VCAP to ANODE voltage must be above the undervoltage lockout threshold, typically 6.6 V, before the internal gate driver is enabled. Use [Equation 1](#) to calculate the initial gate driver enable delay.

$$T_{(DRV_EN)} = 75\mu\text{s} + C_{(VCAP)} \times \frac{V_{(VCAP_UVLOR)}}{300\mu\text{A}} \quad (1)$$

where

- $C_{(VCAP)}$ is the charge pump capacitance connected across ANODE and VCAP pins
- $V_{(VCAP_UVLOR)} = 6.6$ V (typical)

. To remove any chatter on the gate drive approximately 900 mV of hysteresis is added to the VCAP undervoltage lockout. The charge pump remains enabled until the VCAP to ANODE voltage reaches 13 V, typically, at which point the charge pump is disabled decreasing the current draw on the ANODE pin. The charge pump remains disabled until the VCAP to ANODE voltage is below to 12.1 V typically at which point the charge pump is enabled. The voltage between VCAP and ANODE continue to charge and discharge between 12.1 V and 13 V as shown in [Figure 9-1](#). By enabling and disabling the charge pump, the operating quiescent current of the LM74700-Q1 is reduced. When the charge pump is disabled it sinks 5- μA typical.

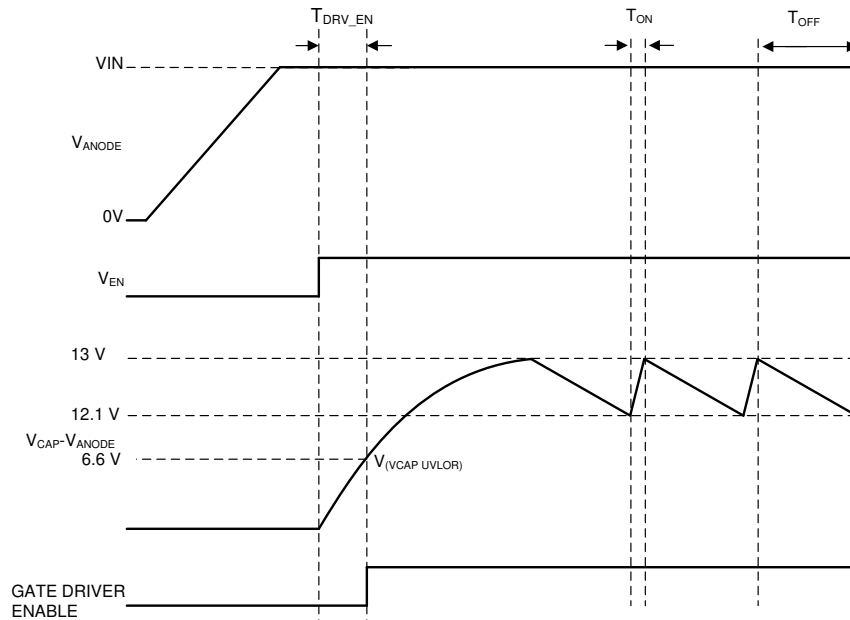

Figure 9-1. Charge Pump Operation

9.3.3 Gate Driver

The gate driver is used to control the external N-Channel MOSFET by setting the GATE to ANODE voltage to the corresponding mode of operation. There are three defined modes of operation that the gate driver operates under forward regulation, full conduction mode and reverse current protection, according to the ANODE to CATHODE voltage. Forward regulation mode, full conduction mode and reverse current protection mode are described in more detail in the [Regulated conduction Mode](#), [Full Conduction Mode](#) and [Reverse Current Production Mode](#) sections. [Figure 9-2](#) depicts how the modes of operation vary according to the ANODE to CATHODE voltage of the LM74700-Q1. The threshold between forward regulation mode and conduction mode is when the ANODE to CATHODE voltage is 50 mV. The threshold between forward regulation mode and reverse current protection mode is when the ANODE to CATHODE voltage is -11 mV.

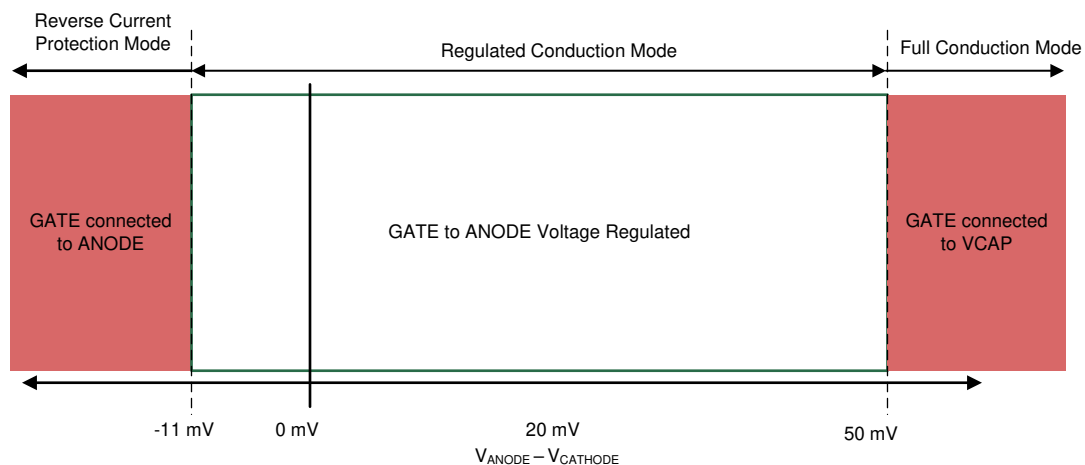

Figure 9-2. Gate Driver Mode Transitions

Before the gate driver is enabled following three conditions must be achieved:

- The EN pin voltage must be greater than the specified input high voltage.
- The VCAP to ANODE voltage must be greater than the undervoltage lockout voltage.
- The ANODE voltage must be greater than VANODE POR Rising threshold.

If the above conditions are not achieved, then the GATE pin is internally connected to the ANODE pin, assuring that the external MOSFET is disabled. Once these conditions are achieved the gate driver operates in the correct mode depending on the ANODE to CATHODE voltage.

9.3.4 Enable

The LM74700-Q1 has an enable pin, EN. The enable pin allows for the gate driver to be either enabled or disabled by an external signal. If the EN pin voltage is greater than the rising threshold, the gate driver and charge pump operates as described in [Gate Driver](#) and [Charge Pump](#) sections. If the enable pin voltage is less than the input low threshold, the charge pump and gate driver are disabled placing the LM74700-Q1 in shutdown mode. The EN pin can withstand a voltage as large as 65 V and as low as –65 V. This allows for the EN pin to be connected directly to the ANODE pin if enable functionality is not needed. In conditions where EN is left floating, the internal sink current of 3 μ A pulls EN pin low and disables the device.

9.4 Device Functional Modes

9.4.1 Shutdown Mode

The LM74700-Q1 enters shutdown mode when the EN pin voltage is below the specified input low threshold $V_{(EN_IL)}$. Both the gate driver and the charge pump are disabled in shutdown mode. During shutdown mode the LM74700-Q1 enters low I_Q operation with the ANODE pin only sinking 1 μ A. When the LM74700-Q1 is in shutdown mode, forward current flow through the external MOSFET is not interrupted but is conducted through the MOSFET's body diode.

9.4.2 Conduction Mode

Conduction mode occurs when the gate driver is enabled. There are three regions of operating during conduction mode based on the ANODE to CATHODE voltage of the LM74700-Q1. Each of the three modes is described in the [Regulated Conduction Mode](#), [Full Conduction Mode](#) and [Reverse Current Protection Mode](#) sections.

9.4.2.1 Regulated Conduction Mode

For the LM74700-Q1 to operate in regulated conduction mode, the gate driver must be enabled as described in the [Gate Driver](#) section and the current from source to drain of the external MOSFET must be within the range to result in an ANODE to CATHODE voltage drop of –11 mV to 50 mV. During forward regulation mode the ANODE to CATHODE voltage is regulated to 20 mV by adjusting the GATE to ANODE voltage. This closed loop regulation scheme enables graceful turn off of the MOSFET at very light loads and ensures zero DC reverse current flow.

9.4.2.2 Full Conduction Mode

For the LM74700-Q1 to operate in full conduction mode the gate driver must be enabled as described in the [Gate Driver](#) section and the current from source to drain of the external MOSFET must be large enough to result in an ANODE to CATHODE voltage drop of greater than 50-mV typical. If these conditions are achieved the GATE pin is internally connected to the VCAP pin resulting in the GATE to ANODE voltage being approximately the same as the VCAP to ANODE voltage. By connecting VCAP to GATE the external MOSFET's $R_{DS(ON)}$ is minimized reducing the power loss of the external MOSFET when forward currents are large.

9.4.2.3 Reverse Current Protection Mode

For the LM74700-Q1 to operate in reverse current protection mode, the gate driver must be enabled as described in the [Gate Driver](#) section and the current of the external MOSFET must be flowing from the drain to the source. When the ANODE to CATHODE voltage is typically less than –11 mV, reverse current protection mode is entered and the GATE pin is internally connected to the ANODE pin. The connection of the GATE to ANODE pin disables the external MOSFET. The body diode of the MOSFET blocks any reverse current from flowing from the drain to source.

10 Application and Implementation

Note

Information in the following applications sections is not part of the TI component specification, and TI does not warrant its accuracy or completeness. TI's customers are responsible for determining suitability of components for their purposes, as well as validating and testing their design implementation to confirm system functionality.

10.1 Application Information

The LM74700-Q1 is used with N-Channel MOSFET controller in a typical reverse polarity protection application. The schematic for the 12-V battery protection application is shown in Figure 10-1 where the LM74700-Q1 is used in series with a battery to drive the MOSFET Q1. The TVS is not required for the LM74700-Q1 to operate, but they are used to clamp the positive and negative voltage surges. The output capacitor C_{OUT} is recommended to protect the immediate output voltage collapse as a result of line disturbance.

10.1.1 Typical Application

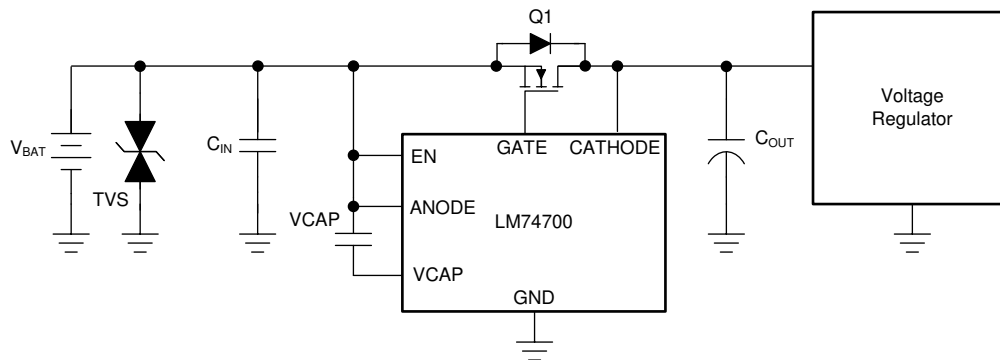

Figure 10-1. Typical Application Circuit

10.1.1.1 Design Requirements

A design example, with system design parameters listed in Table 10-1 is presented.

Table 10-1. Design Parameters

| DESIGN PARAMETER | EXAMPLE VALUE |
|---------------------------|---|
| Input voltage range | 12-V Battery, 12-V Nominal with 3.2-V Cold Crank and 35-V Load Dump |
| Output voltage | 3.2 V during Cold Crank to 35-V Load Dump |
| Output current range | 3-A Nominal, 5-A Maximum |
| Output capacitance | 1- μ F Minimum, 47- μ F Typical Hold Up Capacitance |
| Automotive EMC Compliance | ISO 7637-2 and ISO 16750-2 |

10.1.1.2 Detailed Design Procedure

10.1.1.2.1 Design Considerations

- Input operating voltage range, including cold crank and load dump conditions
- Nominal load current and maximum load current

10.1.1.2.2 MOSFET Selection

The important MOSFET electrical parameters are the maximum continuous drain current I_D , the maximum drain-to-source voltage $V_{DS(MAX)}$, the maximum source current through body diode and the drain-to-source On resistance $R_{DS(ON)}$.

The maximum continuous drain current, I_D , rating must exceed the maximum continuous load current. The maximum drain-to-source voltage, $V_{DS(MAX)}$, must be high enough to withstand the highest differential voltage seen in the application. This would include any anticipated fault conditions. It is recommended to use MOSFETs with voltage rating up to 60-V maximum with the LM74700-Q1 because anode-cathode maximum voltage is 65 V. The maximum V_{GS} LM74700-Q1 can drive is 13 V, so a MOSFET with 15-V minimum V_{GS} should be selected. If a MOSFET with $< 15\text{-V } V_{GS}$ rating is selected, a zener diode can be used to clamp V_{GS} to safe level. During startup, inrush current flows through the body diode to charge the bulk hold-up capacitors at the output. The maximum source current through the body diode must be higher than the inrush current that can be seen in the application.

To reduce the MOSFET conduction losses, lowest possible $R_{DS(ON)}$ is preferred, but selecting a MOSFET based on low $R_{DS(ON)}$ may not be beneficial always. Higher $R_{DS(ON)}$ will provide increased voltage information to LM74700-Q1's reverse comparator at a lower reverse current. Reverse current detection is better with increased $R_{DS(ON)}$. It is recommended to operate the MOSFET in regulated conduction mode during nominal load conditions and select $R_{DS(ON)}$ such that at nominal operating current, forward voltage drop V_{DS} is close to 20-mV regulation point and not more than 50 mV.

As a guideline, it is suggested to choose $(20 \text{ mV} / I_{Load(Nominal)}) \leq R_{DS(ON)} \leq (50 \text{ mV} / I_{Load(Nominal)})$.

MOSFET manufacturers usually specify $R_{DS(ON)}$ at 4.5-V V_{GS} and 10-V V_{GS} . $R_{DS(ON)}$ increases drastically below 4.5-V V_{GS} and $R_{DS(ON)}$ is highest when V_{GS} is close to MOSFET V_{th} . For stable regulation at light load conditions, it is recommended to operate the MOSFET close to 4.5-V V_{GS} , that is, much higher than MOSFET gate threshold voltage. It is recommended to choose MOSFET gate threshold voltage V_{th} of 2-V to 2.5-V maximum. Choosing a lower V_{th} MOSFET also reduces the turn ON time.

Based on the design requirements, preferred MOSFET ratings are:

- 60-V $V_{DS(MAX)}$ and $\pm 20\text{-V } V_{GS(MAX)}$
- $R_{DS(ON)}$ at 3-A nominal current: $(20 \text{ mV} / 3 \text{ A}) \leq R_{DS(ON)} \leq (50 \text{ mV} / 3 \text{ A}) = 6.67 \text{ m}\Omega \leq R_{DS(ON)} \leq 16.67 \text{ m}\Omega$
- MOSFET gate threshold voltage V_{th} : 2V maximum

DMT6007LFG MOSFET from Diodes Inc. is selected to meet this 12-V reverse battery protection design requirements and it is rated at:

- 60-V $V_{DS(MAX)}$ and $\pm 20\text{-V } V_{GS(MAX)}$
- $R_{DS(ON)}$ 6.5-m Ω typical and 8.5-m Ω maximum rated at 4.5-V V_{GS}
- MOSFET V_{th} : 2-V maximum

Thermal resistance of the MOSFET should be considered against the expected maximum power dissipation in the MOSFET to ensure that the junction temperature (T_J) is well controlled.

10.1.1.2.3 Charge Pump VCAP, input and output capacitance

Minimum required capacitance for charge pump VCAP and input/output capacitance are:

- VCAP: Minimum 0.1 μF is required; recommended value of VCAP (μF) $\geq 10 \times C_{ISS(MOSFET)}$ (μF)
- C_{IN} : minimum 22 nF of input capacitance
- C_{OUT} : minimum 100 nF of output capacitance

10.1.1.3 Selection of TVS Diodes for 12-V Battery Protection Applications

TVS diodes are used in automotive systems for protection against transients. In the 12-V battery protection application circuit shown in [Figure 10-2](#), a bi-directional TVS diode is used to protect from positive and negative transient voltages that occur during normal operation of the car and these transient voltage levels and pulses are specified in ISO 7637-2 and ISO 16750-2 standards.

There are two important specifications are breakdown voltage and clamping voltage of the TVS. Breakdown voltage is the voltage at which the TVS diode goes into avalanche similar to a zener diode and is specified at a low current value typical 1 mA and the breakdown voltage should be higher than worst case steady state voltages seen in the system. The breakdown voltage of the TVS+ should be higher than 24-V jump start voltage and 35-V suppressed load dump voltage and less than the maximum ratings of LM74700-Q1 (65 V). The breakdown voltage of TVS- should be beyond than maximum reverse battery voltage -16 V , so that the TVS- is not damaged due to long time exposure to reverse connected battery.

Clamping voltage is the voltage the TVS diode clamps in high current pulse situations and this voltage is much higher than the breakdown voltage. TVS diodes are meant to clamp transient pulses and should not interfere with steady state operation. In the case of an ISO 7637-2 pulse 1, the input voltage goes up to -150 V with a generator impedance of $10\ \Omega$. This translates to 15 A flowing through the TVS - and the voltage across the TVS would be close to its clamping voltage.

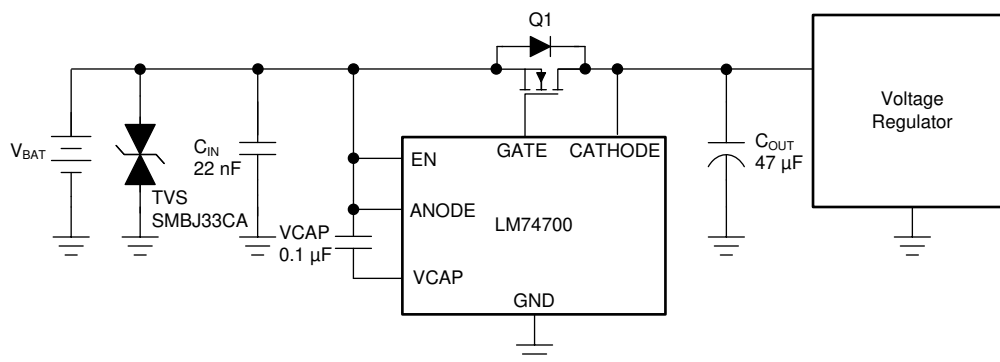

Figure 10-2. Typical 12-V Battery Protection with Single Bi-Directional TVS

The next criterion is that the absolute maximum rating of Anode to Cathode reverse voltage of the LM74700-Q1 (-75 V) and the maximum V_{DS} rating MOSFET are not exceeded. In the design example, 60-V rated MOSFET is chosen and maximum limit on the cathode to anode voltage is 60 V.

In case of ISO 7637-2 pulse 1, the anode of LM74700-Q1 is pulled down by the ISO pulse and clamped by TVS-. The MOSFET is turned off quickly to prevent reverse current from discharging the bulk output capacitors. When the MOSFET turns off, the cathode to anode voltage seen is equal to (TVS Clamping voltage + Output capacitor voltage). If the maximum voltage on output capacitor is 16 V (maximum battery voltage), then the clamping voltage of the TVS- should not exceed, $(60\text{ V} - 16)\text{ V} = -44\text{ V}$.

The SMBJ33CA TVS diode can be used for 12-V battery protection application. The breakdown voltage of 36.7 V meets the jump start, load dump requirements on the positive side and 16-V reverse battery connection on the negative side. During ISO 7637-2 pulse 1 test, the SMBJ33CA clamps at -44 V with 15 A of peak surge current as shown in Figure 10-5 and it meets the clamping voltage $\leq 44\text{ V}$.

SMBJ series of TVS' are rated up to 600-W peak pulse power levels. This is sufficient for ISO 7637-2 pulses and suppressed load dump (ISO-16750-2 pulse B).

10.1.1.4 Selection of TVS Diodes and MOSFET for 24-V Battery Protection Applications

Typical 24-V battery protection application circuit shown in Figure 10-3 uses two uni-directional TVS diodes to protect from positive and negative transient voltages.

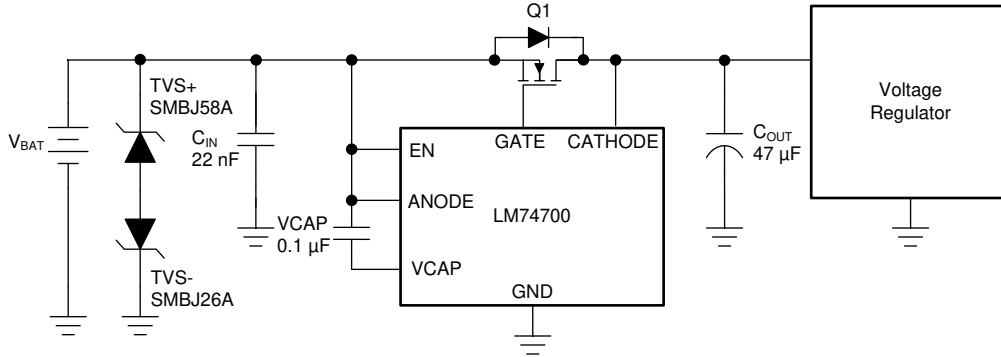

Figure 10-3. Typical 24-V Battery Protection with Two Uni-Directional TVS

The breakdown voltage of the TVS+ should be higher than 48-V jump start voltage, less than the absolute maximum ratings of anode and enable pin of LM74700-Q1 (65 V) and should withstand 65-V suppressed load dump. The breakdown voltage of TVS- should be lower than maximum reverse battery voltage -32 V, so that the TVS- is not damaged due to long time exposure to reverse connected battery.

During ISO 7637-2 pulse 1, the input voltage goes up to -600 V with a generator impedance of 50Ω . This translates to 12 A flowing through the TVS-. The clamping voltage of the TVS- cannot be same as that of 12-V battery protection circuit. Because during the ISO 7637-2 pulse, the Anode to Cathode voltage seen is equal to (-TVS Clamping voltage + Output capacitor voltage). For a 24-V battery application, the maximum battery voltage is 32 V, then the clamping voltage of the TVS- should not exceed, 75 V $- 32$ V = 43 V.

Single bi-directional TVS cannot be used for 24-V battery protection because breakdown voltage for TVS+ ≥ 65 V, maximum clamping voltage is ≤ 43 V and the clamping voltage cannot be less than the breakdown voltage. Two un-directional TVS connected back-back needs to be used at the input. For positive side TVS+, SMBJ58A with the breakdown voltage of 64.4 V (minimum), 67.8 (typical) is recommended. For the negative side TVS-, SMBJ26A with breakdown voltage close to 32 V (to withstand maximum reverse battery voltage -32 V) and maximum clamping voltage of 42.1 V is recommended.

For 24-V battery protection, a 75-V rated MOSFET is recommended to be used along with SMBJ26A and SMBJ58A connected back-back at the input.

10.1.1.5 Application Curves

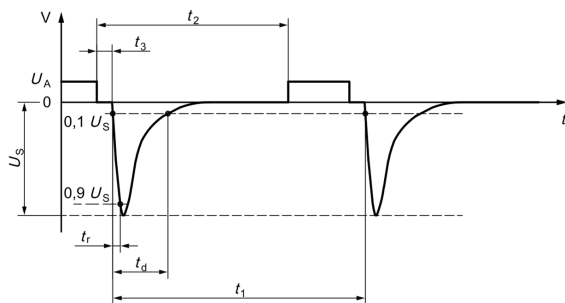

Figure 10-4. ISO 7637-2 Pulse 1

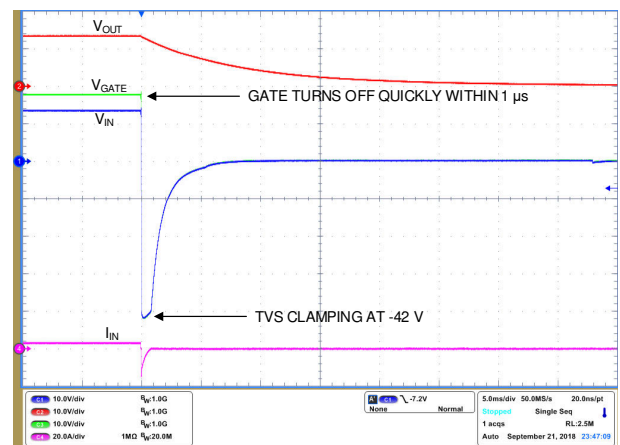
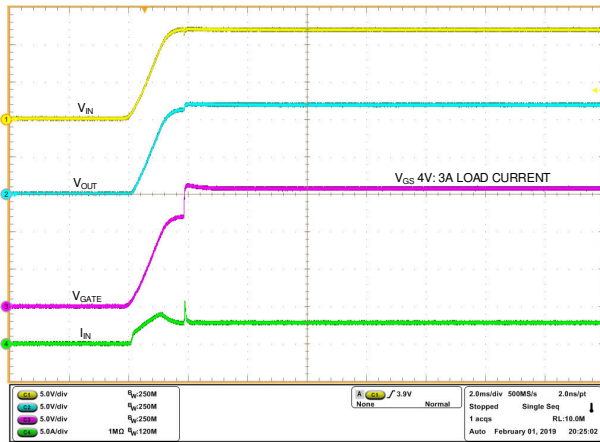
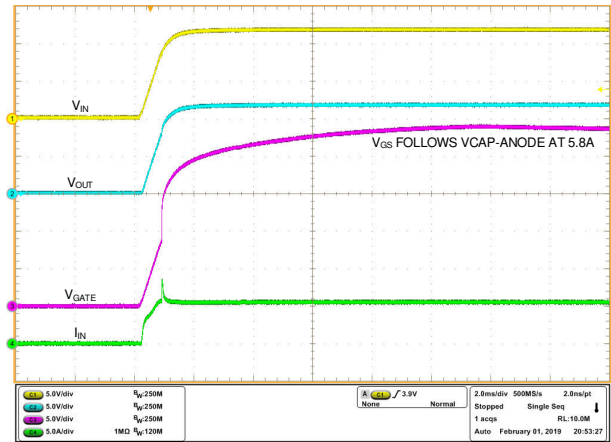

Figure 10-5. Response to ISO 7637-2 Pulse 1



Time (2 ms/DIV)

Figure 10-6. Startup with 3-A Load



Time (2 ms/DIV)

Figure 10-7. Startup with 5.8-A Load

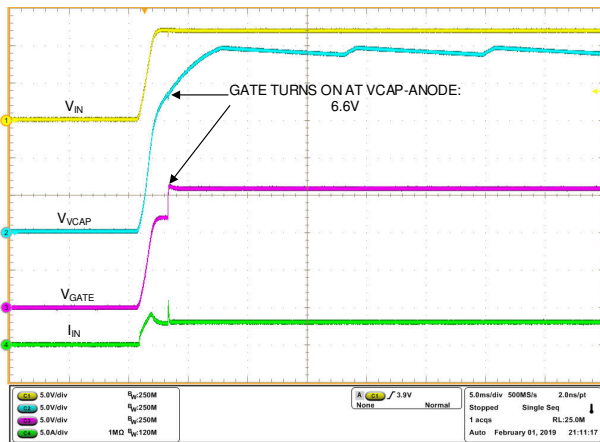

Time (5 ms/DIV)

Figure 10-8. VCAP During Startup at 3-A Load

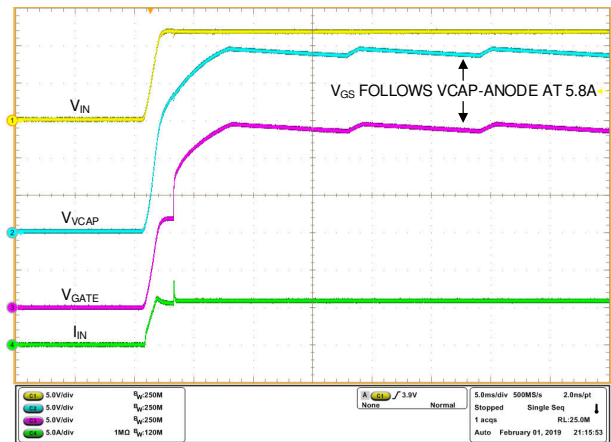

Time (5 ms/DIV)

Figure 10-9. VCAP During Startup at 5.8-A Load

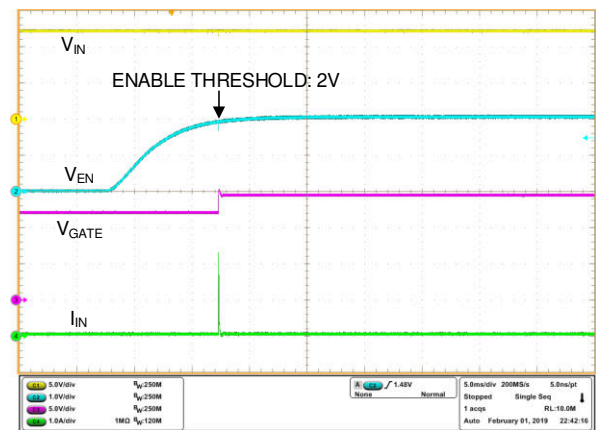

Time (5 ms/DIV)

Figure 10-10. Enable Threshold

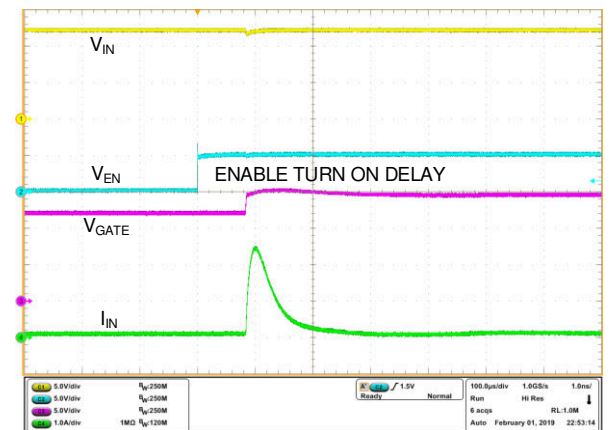

Time (100 μ s/DIV)

Figure 10-11. Enable Turn ON Delay

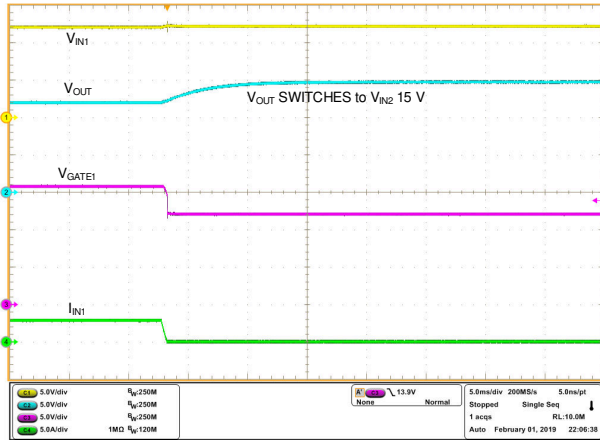

Time (5 ms/DIV)

Figure 10-12. ORing V_{IN1} to V_{IN2} Switch Over

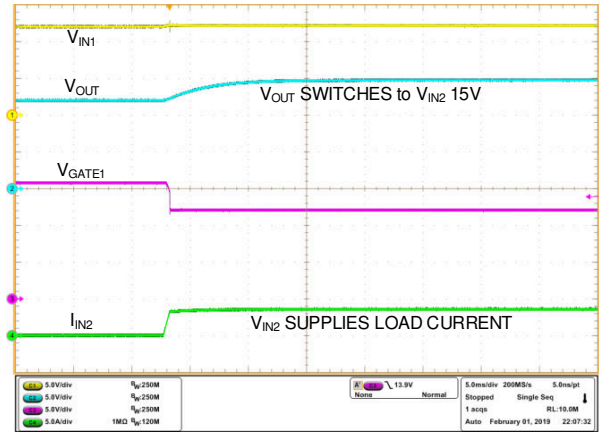

Time (5 ms/DIV)

Figure 10-13. ORing V_{IN1} to V_{IN2} Switch Over

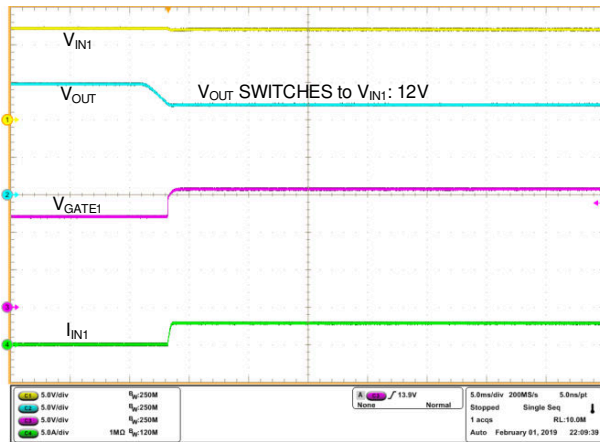

Time (5 ms/DIV)

Figure 10-14. ORing V_{IN2} to V_{IN1} Switch Over

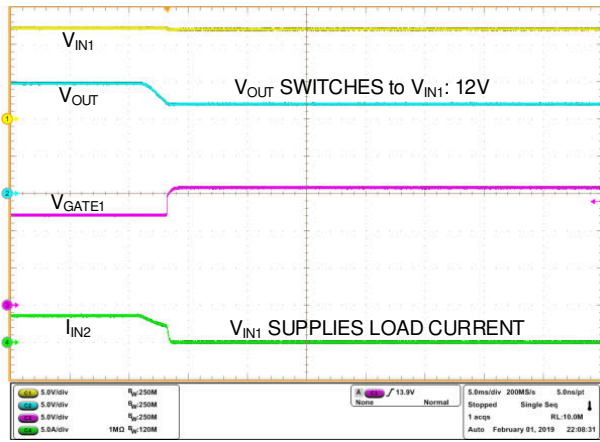

Time (5 ms/DIV)

Figure 10-15. ORing V_{IN2} to V_{IN1} Switch Over

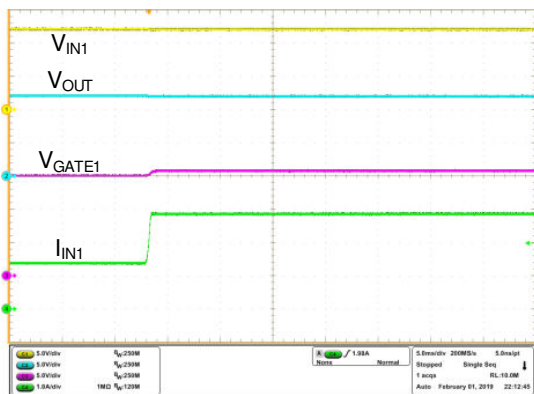

Time (5 ms/DIV)

Figure 10-16. ORing - V_{IN2} Failure and Switch Over to V_{IN1}

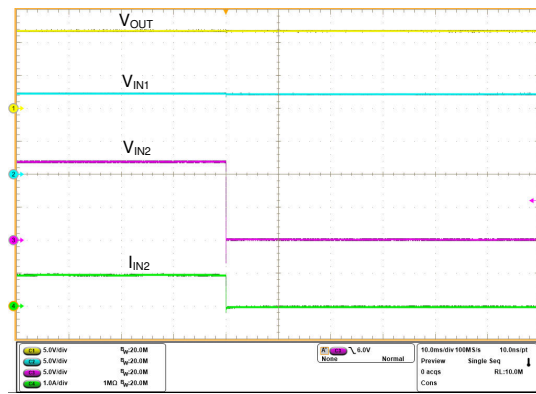

Time (10 ms/DIV)

Figure 10-17. ORing - V_{IN2} Failure and Switch Over to V_{IN1}

10.2 OR-ing Application Configuration

Basic redundant power architecture comprises of two or more voltage or power supply sources driving a single load. In its simplest form, the OR-ing solution for redundant power supplies consists of Schottky OR-ing diodes that protect the system against an input power supply fault condition. A diode OR-ing device provides effective and low cost solution with few components. However, the diodes forward voltage drops affects the efficiency of the system permanently, since each diode in an OR-ing application spends most of its time in forward conduction mode. These power losses increase the requirements for thermal management and allocated board space.

The LM74700-Q1 ICs combined with external N-Channel MOSFETs can be used in OR-ing Solution as shown in Figure 10-18. The forward diode drop is reduced as the external N-Channel MOSFET is turned ON during normal operation. LM74700-Q1 quickly detects the reverse current, pulls down the MOSFET gate fast, leaving the body diode of the MOSFET to block the reverse current flow. An effective OR-ing solution needs to be extremely fast to limit the reverse current amount and duration. The LM74700-Q1 devices in OR-ing configuration constantly sense the voltage difference between Anode and Cathode pins, which are the voltage levels at the power sources (V_{IN1} , V_{IN2}) and the common load point respectively. The source to drain voltage V_{DS} for each MOSFET is monitored by the Anode and Cathode pins of the LM74700-Q1. A fast comparator shuts down the Gate Drive through a fast Pull-Down within $0.45 \mu\text{s}$ (typical) as soon as $V_{(IN)} - V_{(OUT)}$ falls below -11 mV . It turns on the Gate with 11-mA gate charge current once the differential forward voltage $V_{(IN)} - V_{(OUT)}$ exceeds 50 mV .

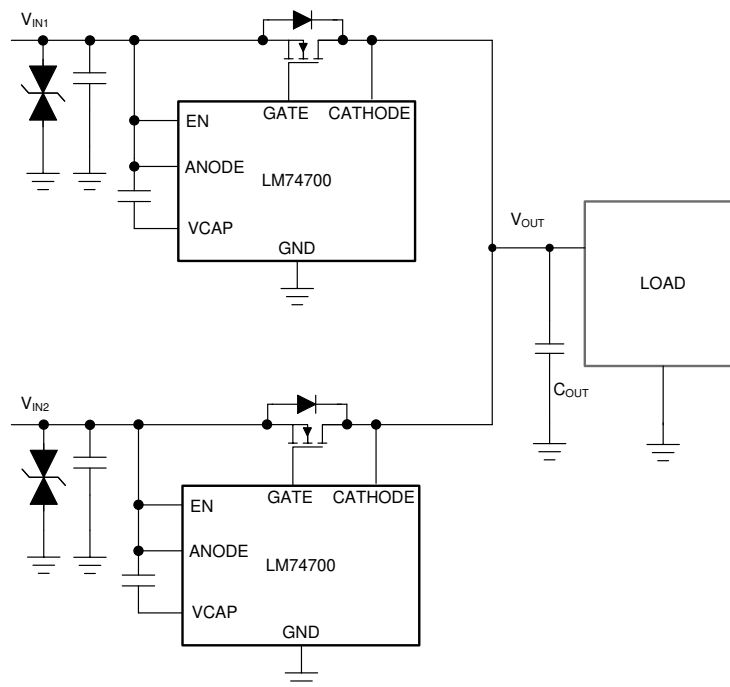

Figure 10-18. Typical OR-ing Application

Figure 10-12 to Figure 10-15 show the smooth switch over between two power supply rails V_{IN1} at 12 V and V_{IN2} at 15 V. Figure 10-16 and Figure 10-17 illustrate the performance when V_{IN2} fails. LM74700-Q1 controlling V_{IN2} power rail turns off quickly, so that the output remains uninterrupted and V_{IN1} is protected from V_{IN2} failure.

11 Power Supply Recommendations

The LM74700-Q1 Ideal Diode Controller designed for the supply voltage range of $3.2 \text{ V} \leq V_{ANODE} \leq 65 \text{ V}$. If the input supply is located more than a few inches from the device, an input ceramic bypass capacitor higher than 22 nF is recommended. To prevent LM74700-Q1 and surrounding components from damage under the conditions of a direct output short circuit, it is necessary to use a power supply having over load and short circuit protection.

12 Layout

12.1 Layout Guidelines

- Connect ANODE, GATE and CATHODE pins of LM74700-Q1 close to the MOSFET's SOURCE, GATE and DRAIN pins.
- The high current path of for this solution is through the MOSFET, therefore it is important to use thick traces for source and drain of the MOSFET to minimize resistive losses.
- The charge pump capacitor across VCAP and ANODE pins must be kept away from the MOSFET to lower the thermal effects on the capacitance value.
- The Gate pin of the LM74700-Q1 must be connected to the MOSFET gate with short trace. Avoid excessively thin and long trace to the Gate Drive.
- Keep the GATE pin close to the MOSFET to avoid increase in MOSFET turn-off delay due to trace resistance.
- Obtaining acceptable performance with alternate layout schemes is possible, however the layout shown in the [Layout Example](#) is intended as a guideline and to produce good results.

12.2 Layout Example

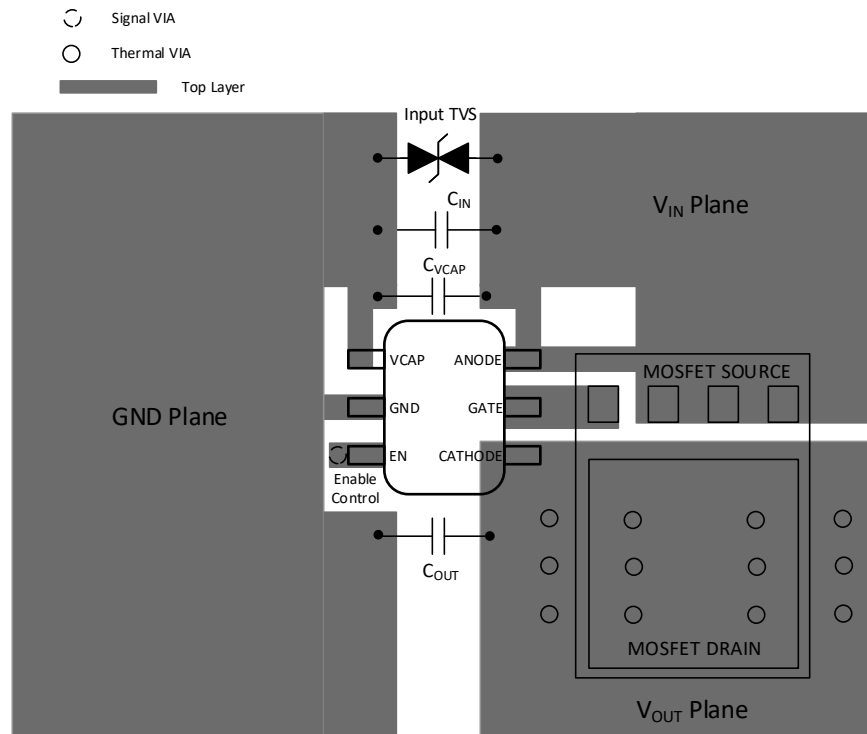

Figure 12-1. LM74700-Q1 DBV Package Example Layout

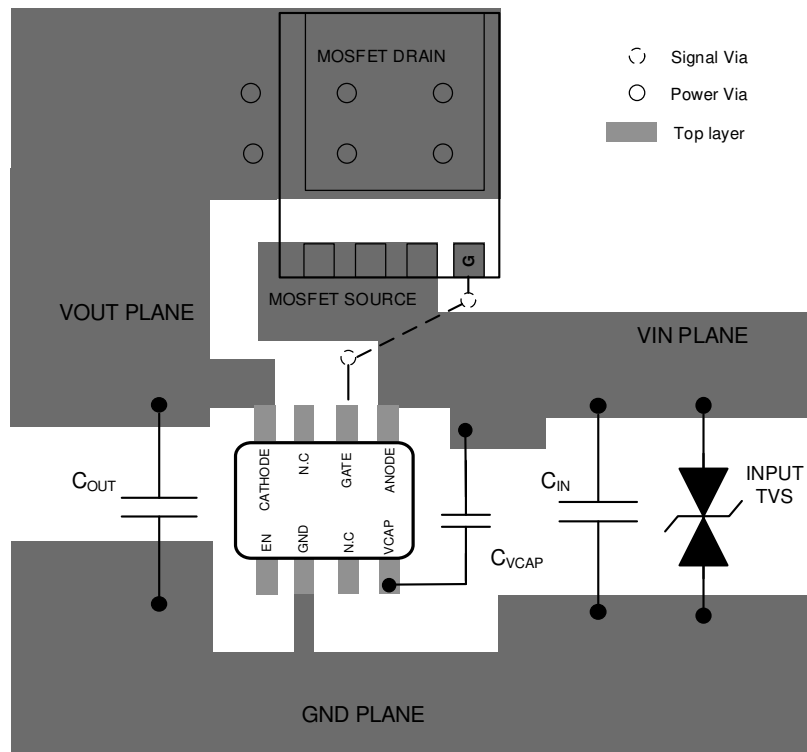

Figure 12-2. LM74700-Q1 DDF Package Example Layout

13 Device and Documentation Support

13.1 Receiving Notification of Documentation Updates

To receive notification of documentation updates, navigate to the device product folder on ti.com. Click on *Subscribe to updates* to register and receive a weekly digest of any product information that has changed. For change details, review the revision history included in any revised document.

13.2 Support Resources

[TI E2E™ support forums](#) are an engineer's go-to source for fast, verified answers and design help — straight from the experts. Search existing answers or ask your own question to get the quick design help you need.

Linked content is provided "AS IS" by the respective contributors. They do not constitute TI specifications and do not necessarily reflect TI's views; see TI's [Terms of Use](#).

13.3 Trademarks

TI E2E™ is a trademark of Texas Instruments.
All trademarks are the property of their respective owners.

13.4 Electrostatic Discharge Caution



This integrated circuit can be damaged by ESD. Texas Instruments recommends that all integrated circuits be handled with appropriate precautions. Failure to observe proper handling and installation procedures can cause damage.

ESD damage can range from subtle performance degradation to complete device failure. Precision integrated circuits may be more susceptible to damage because very small parametric changes could cause the device not to meet its published specifications.

13.5 Glossary

[TI Glossary](#) This glossary lists and explains terms, acronyms, and definitions.

14 Mechanical, Packaging, and Orderable Information

The following pages include mechanical, packaging, and orderable information. This information is the most current data available for the designated devices. This data is subject to change without notice and revision of this document. For browser-based versions of this data sheet, refer to the left-hand navigation.

PACKAGING INFORMATION

| Orderable Device | Status (1) | Package Type | Package Drawing | Pins | Package Qty | Eco Plan (2) | Lead finish/ Ball material (6) | MSL Peak Temp (3) | Op Temp (°C) | Device Marking (4/5) | Samples |
|------------------|---------------|--------------|-----------------|------|-------------|-----------------|--------------------------------------|----------------------|--------------|-------------------------|-------------------------|
| LM74700QDBVRQ1 | ACTIVE | SOT-23 | DBV | 6 | 3000 | RoHS & Green | NIPDAU | Level-2-260C-1 YEAR | -40 to 125 | M747 | Samples |
| LM74700QDBVTQ1 | ACTIVE | SOT-23 | DBV | 6 | 250 | RoHS & Green | NIPDAU | Level-2-260C-1 YEAR | -40 to 125 | M747 | Samples |
| LM74700QDDFRQ1 | ACTIVE | SOT-23-THIN | DDF | 8 | 3000 | RoHS & Green | NIPDAU | Level-1-260C-UNLIM | -40 to 125 | 747F | Samples |

(1) The marketing status values are defined as follows:

ACTIVE: Product device recommended for new designs.

LIFEBUY: TI has announced that the device will be discontinued, and a lifetime-buy period is in effect.

NRND: Not recommended for new designs. Device is in production to support existing customers, but TI does not recommend using this part in a new design.

PREVIEW: Device has been announced but is not in production. Samples may or may not be available.

OBSOLETE: TI has discontinued the production of the device.

(2) **RoHS:** TI defines "RoHS" to mean semiconductor products that are compliant with the current EU RoHS requirements for all 10 RoHS substances, including the requirement that RoHS substance do not exceed 0.1% by weight in homogeneous materials. Where designed to be soldered at high temperatures, "RoHS" products are suitable for use in specified lead-free processes. TI may reference these types of products as "Pb-Free".

RoHS Exempt: TI defines "RoHS Exempt" to mean products that contain lead but are compliant with EU RoHS pursuant to a specific EU RoHS exemption.

Green: TI defines "Green" to mean the content of Chlorine (Cl) and Bromine (Br) based flame retardants meet JS709B low halogen requirements of <=1000ppm threshold. Antimony trioxide based flame retardants must also meet the <=1000ppm threshold requirement.

(3) MSL, Peak Temp. - The Moisture Sensitivity Level rating according to the JEDEC industry standard classifications, and peak solder temperature.

(4) There may be additional marking, which relates to the logo, the lot trace code information, or the environmental category on the device.

(5) Multiple Device Markings will be inside parentheses. Only one Device Marking contained in parentheses and separated by a "~" will appear on a device. If a line is indented then it is a continuation of the previous line and the two combined represent the entire Device Marking for that device.

(6) Lead finish/Ball material - Orderable Devices may have multiple material finish options. Finish options are separated by a vertical ruled line. Lead finish/Ball material values may wrap to two lines if the finish value exceeds the maximum column width.

Important Information and Disclaimer:The information provided on this page represents TI's knowledge and belief as of the date that it is provided. TI bases its knowledge and belief on information provided by third parties, and makes no representation or warranty as to the accuracy of such information. Efforts are underway to better integrate information from third parties. TI has taken and continues to take reasonable steps to provide representative and accurate information but may not have conducted destructive testing or chemical analysis on incoming materials and chemicals. TI and TI suppliers consider certain information to be proprietary, and thus CAS numbers and other limited information may not be available for release.

In no event shall TI's liability arising out of such information exceed the total purchase price of the TI part(s) at issue in this document sold by TI to Customer on an annual basis.

TAPE AND REEL INFORMATION



QUADRANT ASSIGNMENTS FOR PIN 1 ORIENTATION IN TAPE



*All dimensions are nominal

| Device | Package Type | Package Drawing | Pins | SPQ | Reel Diameter (mm) | Reel Width W1 (mm) | A0 (mm) | B0 (mm) | K0 (mm) | P1 (mm) | W (mm) | Pin1 Quadrant |
|----------------|--------------|-----------------|------|------|--------------------|--------------------|---------|---------|---------|---------|--------|---------------|
| LM74700QDBVRQ1 | SOT-23 | DBV | 6 | 3000 | 180.0 | 8.4 | 3.2 | 3.2 | 1.4 | 4.0 | 8.0 | Q3 |
| LM74700QDBVTQ1 | SOT-23 | DBV | 6 | 250 | 180.0 | 8.4 | 3.2 | 3.2 | 1.4 | 4.0 | 8.0 | Q3 |
| LM74700QDDFRQ1 | SOT-23-THIN | DDF | 8 | 3000 | 180.0 | 8.4 | 3.2 | 3.2 | 1.4 | 4.0 | 8.0 | Q3 |

TAPE AND REEL BOX DIMENSIONS

*All dimensions are nominal

| Device | Package Type | Package Drawing | Pins | SPQ | Length (mm) | Width (mm) | Height (mm) |
|----------------|--------------|-----------------|------|------|-------------|------------|-------------|
| LM74700QDBVRQ1 | SOT-23 | DBV | 6 | 3000 | 213.0 | 191.0 | 35.0 |
| LM74700QDBVTQ1 | SOT-23 | DBV | 6 | 250 | 213.0 | 191.0 | 35.0 |
| LM74700QDDFRQ1 | SOT-23-THIN | DDF | 8 | 3000 | 210.0 | 185.0 | 35.0 |

DDF0008A



PACKAGE OUTLINE

SOT-23-THIN - 1.1 mm max height

PLASTIC SMALL OUTLINE



4222047/E 07/2024

NOTES:

1. All linear dimensions are in millimeters. Any dimensions in parenthesis are for reference only. Dimensioning and tolerancing per ASME Y14.5M.
2. This drawing is subject to change without notice.
3. This dimension does not include mold flash, protrusions, or gate burrs. Mold flash, protrusions, or gate burrs shall not exceed 0.15 mm per side.

EXAMPLE BOARD LAYOUT

DDF0008A

SOT-23-THIN - 1.1 mm max height

PLASTIC SMALL OUTLINE



LAND PATTERN EXAMPLE
EXPOSED METAL SHOWN
SCALE:15X



SOLDER MASK DETAILS

4222047/E 07/2024

NOTES: (continued)

- 4. Publication IPC-7351 may have alternate designs.
- 5. Solder mask tolerances between and around signal pads can vary based on board fabrication site.

EXAMPLE STENCIL DESIGN

DDF0008A

SOT-23-THIN - 1.1 mm max height

PLASTIC SMALL OUTLINE



SOLDER PASTE EXAMPLE
BASED ON 0.125 mm THICK STENCIL
SCALE:15X

4222047/E 07/2024

NOTES: (continued)

6. Laser cutting apertures with trapezoidal walls and rounded corners may offer better paste release. IPC-7525 may have alternate design recommendations.
7. Board assembly site may have different recommendations for stencil design.

DBV0006A



PACKAGE OUTLINE

SOT-23 - 1.45 mm max height

SMALL OUTLINE TRANSISTOR



4214840/G 08/2024

NOTES:

1. All linear dimensions are in millimeters. Any dimensions in parenthesis are for reference only. Dimensioning and tolerancing per ASME Y14.5M.
2. This drawing is subject to change without notice.
3. Body dimensions do not include mold flash or protrusion. Mold flash and protrusion shall not exceed 0.25 per side.
4. Leads 1,2,3 may be wider than leads 4,5,6 for package orientation.
5. Reference JEDEC MO-178.

EXAMPLE BOARD LAYOUT

DBV0006A

SOT-23 - 1.45 mm max height

SMALL OUTLINE TRANSISTOR



LAND PATTERN EXAMPLE
EXPOSED METAL SHOWN
SCALE:15X



SOLDER MASK DETAILS

4214840/G 08/2024

NOTES: (continued)

6. Publication IPC-7351 may have alternate designs.

7. Solder mask tolerances between and around signal pads can vary based on board fabrication site.

EXAMPLE STENCIL DESIGN

DBV0006A

SOT-23 - 1.45 mm max height

SMALL OUTLINE TRANSISTOR



SOLDER PASTE EXAMPLE
BASED ON 0.125 mm THICK STENCIL
SCALE:15X

4214840/G 08/2024

NOTES: (continued)

8. Laser cutting apertures with trapezoidal walls and rounded corners may offer better paste release. IPC-7525 may have alternate design recommendations.
9. Board assembly site may have different recommendations for stencil design.

IMPORTANT NOTICE AND DISCLAIMER

TI PROVIDES TECHNICAL AND RELIABILITY DATA (INCLUDING DATA SHEETS), DESIGN RESOURCES (INCLUDING REFERENCE DESIGNS), APPLICATION OR OTHER DESIGN ADVICE, WEB TOOLS, SAFETY INFORMATION, AND OTHER RESOURCES "AS IS" AND WITH ALL FAULTS, AND DISCLAIMS ALL WARRANTIES, EXPRESS AND IMPLIED, INCLUDING WITHOUT LIMITATION ANY IMPLIED WARRANTIES OF MERCHANTABILITY, FITNESS FOR A PARTICULAR PURPOSE OR NON-INFRINGEMENT OF THIRD PARTY INTELLECTUAL PROPERTY RIGHTS.

These resources are intended for skilled developers designing with TI products. You are solely responsible for (1) selecting the appropriate TI products for your application, (2) designing, validating and testing your application, and (3) ensuring your application meets applicable standards, and any other safety, security, regulatory or other requirements.

These resources are subject to change without notice. TI grants you permission to use these resources only for development of an application that uses the TI products described in the resource. Other reproduction and display of these resources is prohibited. No license is granted to any other TI intellectual property right or to any third party intellectual property right. TI disclaims responsibility for, and you will fully indemnify TI and its representatives against, any claims, damages, costs, losses, and liabilities arising out of your use of these resources.

TI's products are provided subject to [TI's Terms of Sale](#) or other applicable terms available either on [ti.com](https://www.ti.com) or provided in conjunction with such TI products. TI's provision of these resources does not expand or otherwise alter TI's applicable warranties or warranty disclaimers for TI products.

TI objects to and rejects any additional or different terms you may have proposed.

Mailing Address: Texas Instruments, Post Office Box 655303, Dallas, Texas 75265
Copyright © 2024, Texas Instruments Incorporated