

# EVM User's Guide: MCF8316DEVM

## MCF8316D Evaluation Module

---



### Description

The MCF8316DEVM enables users to evaluate the performance of the MCF8316D motor driver. The EVM includes an onboard FTDI chip to convert USB communication, from the micro-USB connector, into UART. An onboard MSP430FR2355 microcontroller (MCU) translates the UART communication into either control signals or I2C formatted data, which is sent to the MCF8316. There are many user-selectable jumpers, resistors, connectors, and test points to assist with evaluating the many features of the MCF8316 IC and the configurable device-specific settings.

### Get Started

1. Download the latest design files from the [MCF8316DEVM tool page](#) on ti.com
2. Download the latest version of the Motor Studio GUI and firmware from the [Motor Studio tool page](#) on ti.com

### Features

- GUI software to simplify the MCx tuning process and performance evaluation
- MCU-to-MCx shunt jumper header with removable shunts to disconnect main signals going to the motor driver IC from the MCU
  - The shunts can be removed if the user desires to control the MCF8316 IC with an external MCU or to use the EVM MCU to control an external MCF8316 IC

### Applications

- [Brushless-DC \(BLDC\) motor modules](#)
- [Washer and Dishwasher Pumps](#)
- [Air Purifiers and Humidifier Fans](#)
- [Residential and Living Fans](#)
- [CPAP Machines](#)

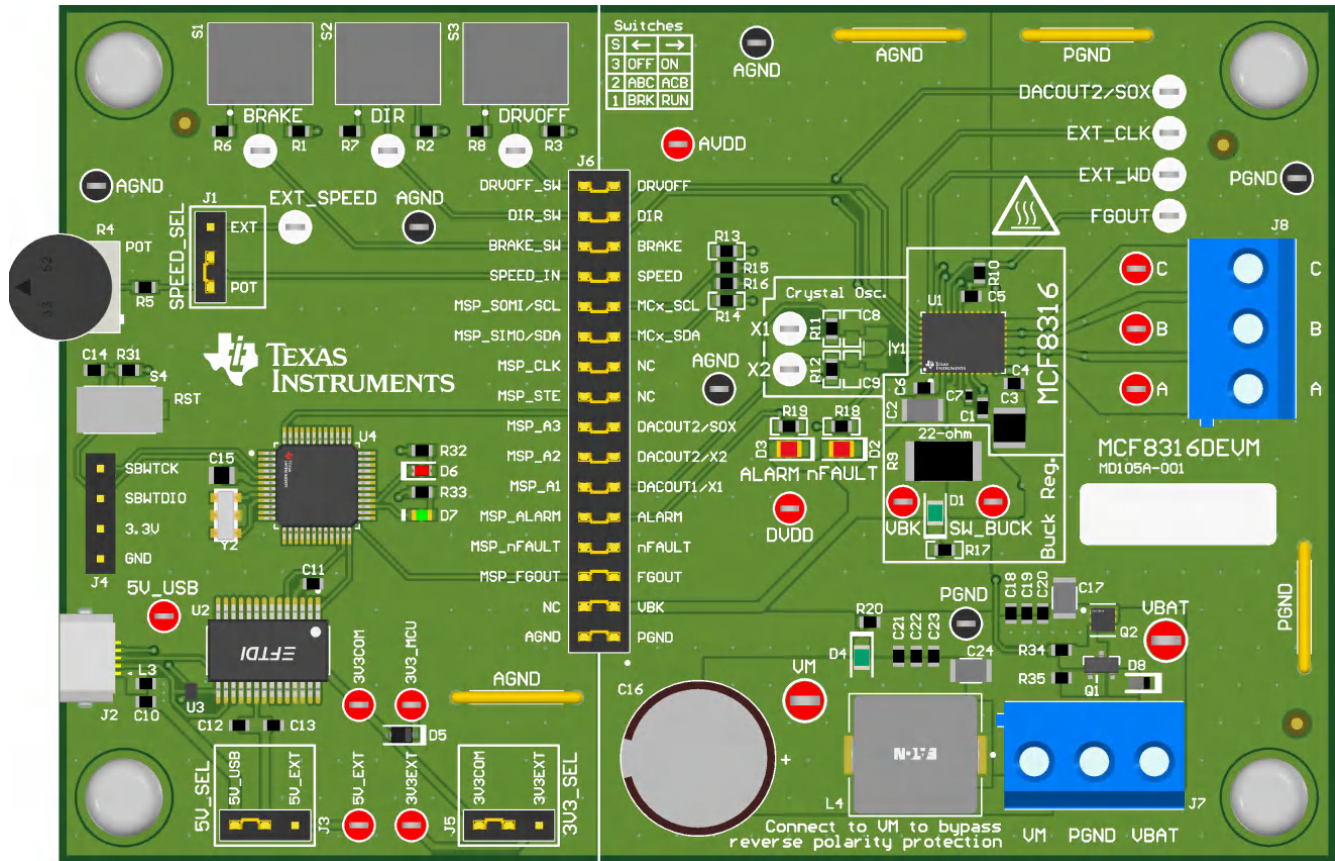

**MCF8316DEVM (Top View)**

## Table of Contents

<b>Description</b> .....	1
<b>Get Started</b> .....	1
<b>Features</b> .....	1
<b>Applications</b> .....	1
<b>1 Evaluation Module Overview</b> .....	4
1.1 Introduction.....	4
1.2 Kit Contents.....	4
1.3 Device Information.....	4
1.4 Specification.....	5
<b>2 Hardware</b> .....	6
2.1 Quick Start Guide.....	6
2.2 Hardware Setup.....	6
<b>3 Hardware Connections Overview</b> .....	8
<b>4 Connection Details</b> .....	9
<b>5 MSP430FR2355 Microcontroller &amp; User Interface</b> .....	11
<b>6 LED Lights</b> .....	13
<b>7 User-Configurable Settings</b> .....	14
<b>8 Software</b> .....	15
8.1 Firmware and GUI Application.....	15
8.2 Downloading and running Motor Studio.....	15
8.3 Downloading Code Composer Studio and Importing GUI Firmware.....	16
8.4 Using eZ-FET to Program the Onboard MSP430FR2355.....	16
<b>9 Hardware Design Files</b> .....	18
9.1 Schematics.....	18
9.2 PCB Layouts.....	23
9.3 Bill of Materials (BOM).....	29

---

<b>10 Additional Information</b> .....	<b>34</b>
<b>11 Revision History</b> .....	<b>34</b>

# 1 Evaluation Module Overview

## 1.1 Introduction

This user's guide details how to set up, configure, and operate the Motor Studio GUI and MCF8316DEVM. Throughout this document, the terms evaluation board, evaluation module, and EVM are synonymous with the MCF8316DEVM. This document also provides information on the operating procedure, input and output connections, an electrical schematic, printed circuit board (PCB) layout drawings, and a bill of materials (BOM) for the EVM.

<b>WARNING</b>		
	<b>Hot Surface</b>	Contact with marked surfaces can cause burns. Do not touch.

## 1.2 Kit Contents

The contents of the EVM kit are listed in [Table 1-1](#). Contact your nearest Texas Instruments Product Information Center if any components are missing. TI highly recommends that users check the TI website at <https://www.ti.com> to verify that the latest version of the related software is being used.

**Table 1-1. Kit Contents**

Item	Quantity
MCF8316DEVM	1
USB-A to USB-B micro-cable	1

## 1.3 Device Information

The MCF8316D is a 4.5V to 35V, 8A peak integrated three-phase gate driver IC with code-free sensorless field oriented control (FOC) for motor drive applications. It provides three accurately trimmed and temperature compensated half-bridge MOSFETS, gate drivers, charge pump, three current sense amplifiers, a linear regulator for the external load and an adjustable buck regulator.

The internal sensorless FOC algorithm register configuration can be stored in non-volatile EEPROM enabling the device to operate stand-alone once the algorithm has been configured. The device can receive a speed command through a PWM input, analog voltage, variable frequency square wave, or I2C command. There are a large number of protection features integrated into the MCF8316, intended to protect the device, motor, and system against fault events.

Part Number	Firmware Version
MCF8316D1VRGFR	D

## 1.4 Specification

The MCF8316DEVM is rated for operation of 40V absolute maximum and currents up to 8A peak. To prevent personal injury, electrical shock hazard, damage to the EVM, or a combination confirm that the EVMs voltage and current specifications are not exceeded.

The MCF8316DEVM can support multiple variants of the MCF8316. To check which MCF8316 chip is populated on the EVM, check the sticker label for the part number of the chip populated by default.

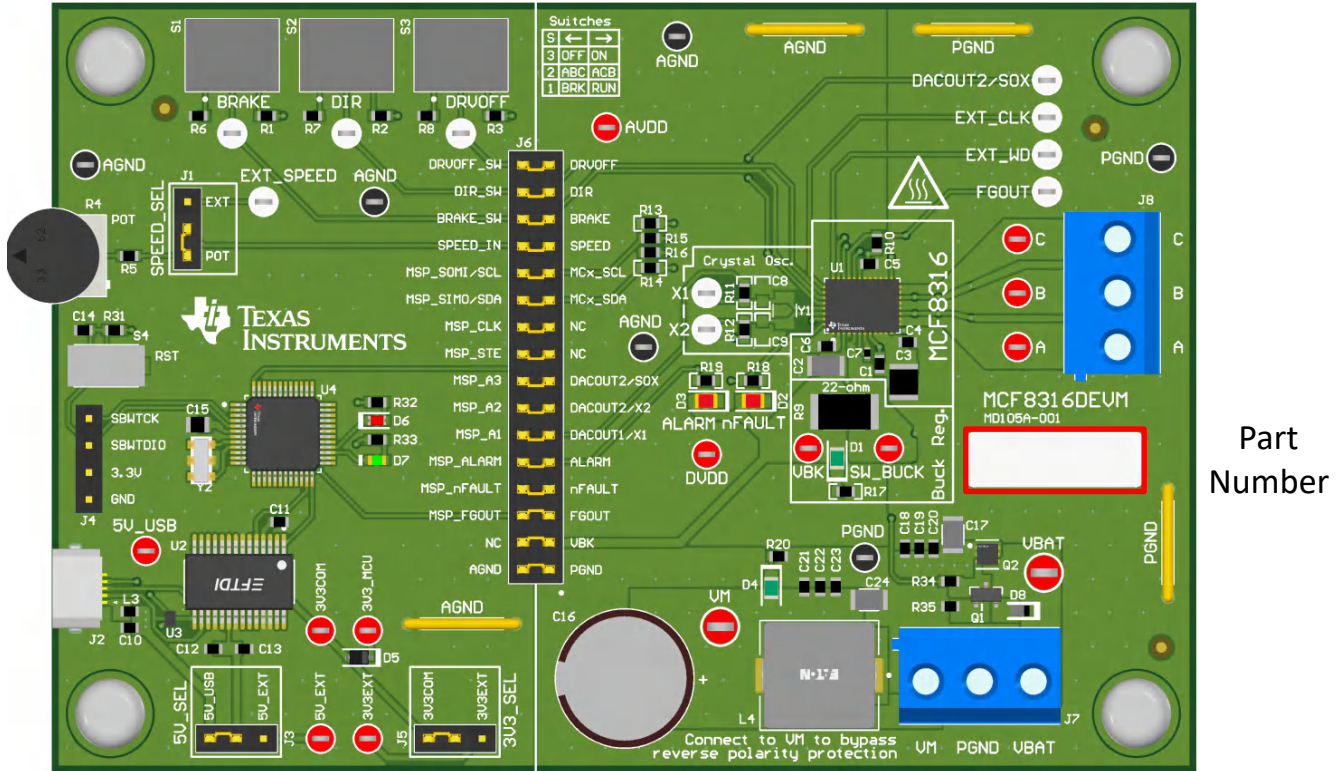

Figure 1-1. MCF8316DEVM Part Number

## 2 Hardware

### 2.1 Quick Start Guide

The MCF8316DEVM requires a power supply source with a recommended operating range from 4.5V to 35V. To set up and power the EVM, follow the sequence below:

1. Connect motor phases to A, B, and C on connector J8.
2. Do not turn on the power supply yet. Connect the motor supply to VBAT/VM and PGND on connector J7.
  - a. Connect to VBAT to enable reverse polarity protection and Pi filter. Note that when connecting to VBAT, VM will be  $VM - 0.7V$  less due to a diode drop in the reverse-polarity protection circuit.
  - b. To disable reverse-polarity protection and the Pi filter, connect to VM.
3. Select J3 to 5V\_USB and J5 to 3V3COM to power MSP430 from USB power supply.
4. Connect the micro-USB cable into the computer.
5. Turn the potentiometer fully clockwise to set the motor to zero speed upon powerup.
6. Flip the switch S1 to the right to configure BRAKE = RUN, switch S2 to the left to configure DIR = ABC, and switch S3 to the right to configure DRVOFF = ON
7. Turn on the motor power supply.
8. Use the potentiometer R4 to control the speed of the motor and the switches to disable the motor driver, change the direction, or apply a brake to the motor. Optionally, use the Motor Studio GUI to monitor real-time speed of the motor, put the MCF8316D into a low-power sleep mode, and read status of the LED as shown in [Section 8](#).

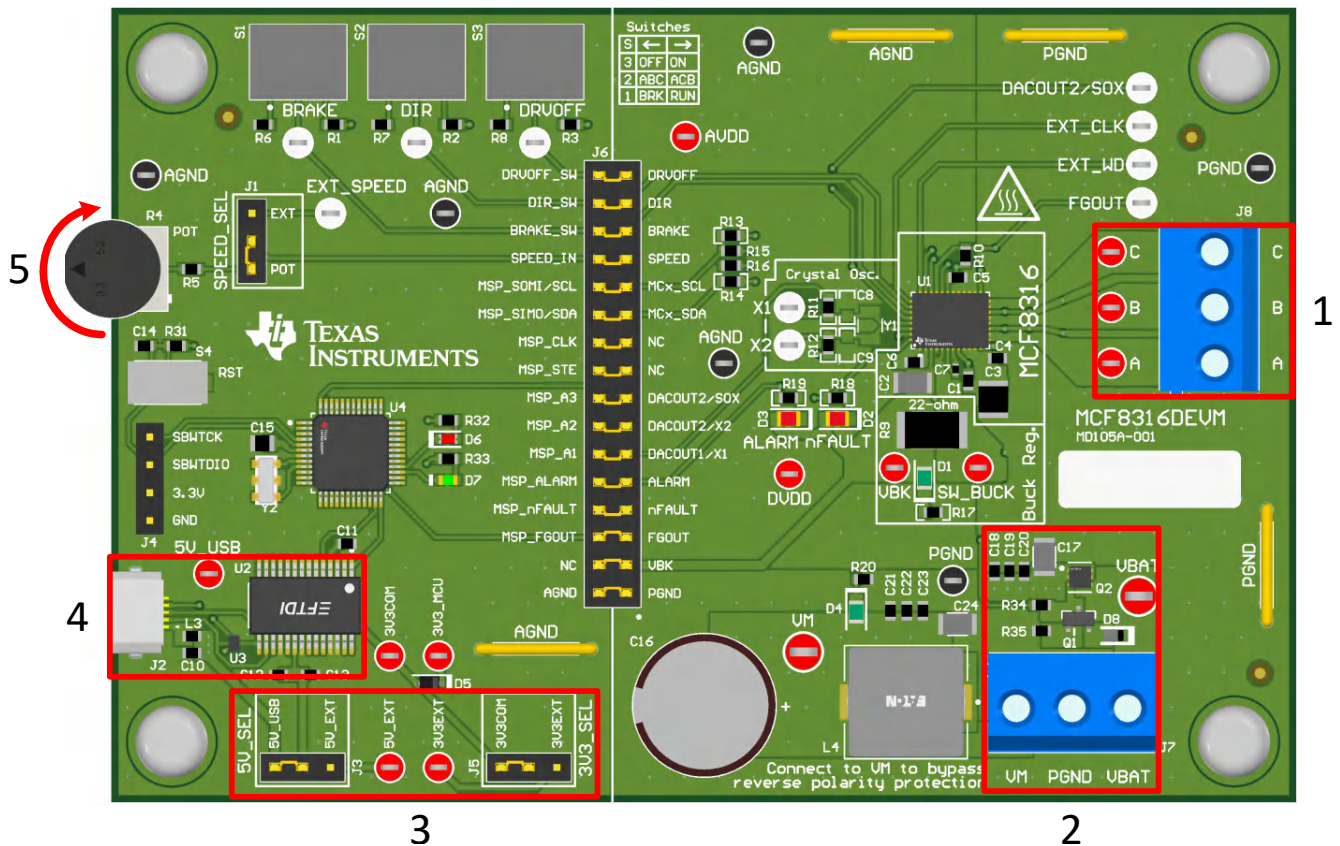

Figure 2-1. Reference for Quick Start Guide

### 2.2 Hardware Setup

The hardware required to run the motor is the MCF8316DEVM, a Micro-USB cable, and a power supply with a DC output from 4.5V to 35V. Follow these steps to start up the MCF8316DEVM:

1. Connect the DC power supply to header J7. Connect to VBAT and PGND to apply reverse polarity protection and the pi filter to the EVM. Otherwise, connect to VM and PGND to bypass the reverse polarity protection and pi filter.
2. Apply user configurable jumper settings. See [Section 7](#) section for more information.
3. Flash program into the MCU as described in [Section 5](#). Launch the GUI in GUI Composer and disconnect the 4-pin JTAG connections.
4. Connect a Micro-USB cable to the MCF8316DEVM and computer.
5. Turn on the power supply and power up the PCB.

If using the MCF8316DEVM with an external microcontroller, remove all shunt jumpers from jumper bridge J6. Connect with external jumpers to the left side of the jumper bridge from the external MCU.

### 3 Hardware Connections Overview

Figure 3-1 shows the major blocks of MCF8316D evaluation module. The MCF8316DEVM is designed for an input supply from 4.5V to 35V. The MCF8316D includes three integrated half-bridges and implements a sensorless FOC algorithm to spin a motor with up to 8A peak current. It also integrates an adjustable buck regulator. For interfacing with the GUI, the MCF8316DEVM has an onboard FTDI chip and MSP430FR2355.

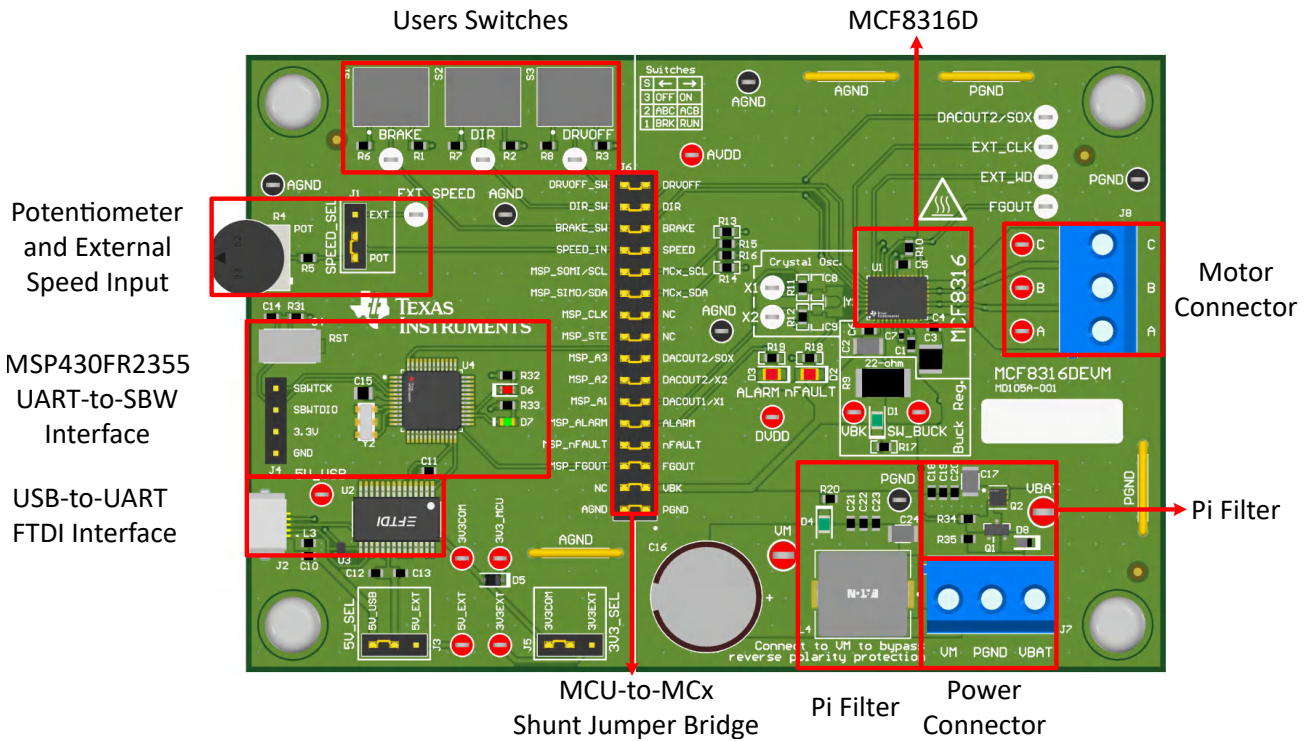

**Figure 3-1. MCF8316DEVM Major Hardware Blocks**



## 4 Connection Details

Figure 4-1 shows the connections made to the MCF8316DEVM in order to spin a 3-phase sensorless Brushless-DC motor.

An 4.5V to 35V power supply or battery is connected to the VBAT or VM and PGND terminals on connector J7. There is a reverse polarity protection and Pi filter implemented on the VBAT and PGND terminals. To bypass the reverse polarity protection and Pi filter, connect the power supply to the VM terminal or VM test point on the board and PGND.

The three phases of the BLDC motor connect directly to the A, B, and C terminals of the screw terminal connector J8.

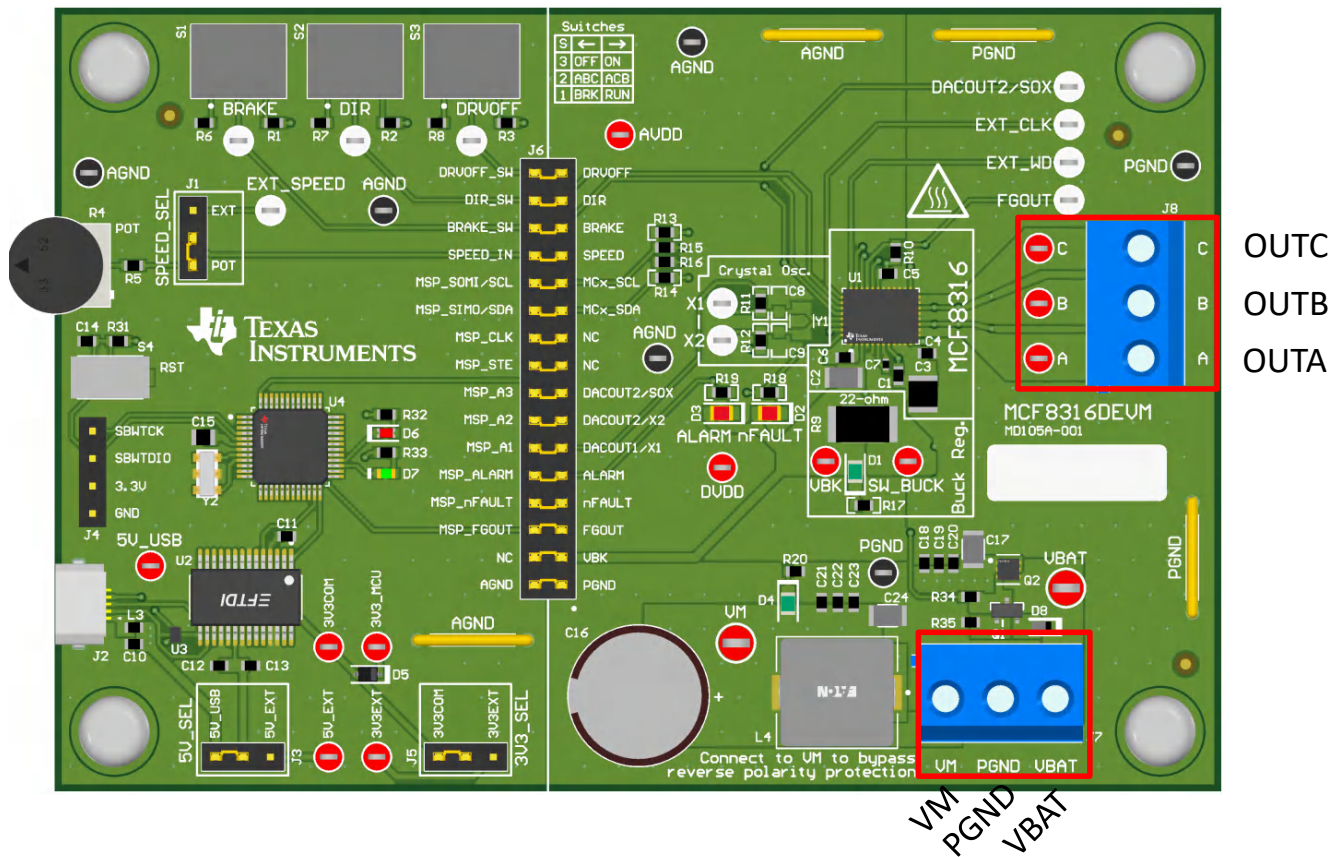

**Figure 4-1. Connections from Motor to MCF8316DEVM**

Figure 4-2 shows where the micro-USB cable is plugged into the MCF8316DEVM to provide communication between the evaluation module and GUI. The USB data and 5V power from the USB is converted into UART data and 3.3 V power to power the MSP430FR2355 microcontroller. The 5V from the USB power is limited to 500mA and the 3.3V from the FTDI chip is limited to 30mA. If the user wishes to supply more current to these rails, they may use the 5V\_SEL jumper J3 and 3V3\_SEL jumper J5 to connect external power rails.

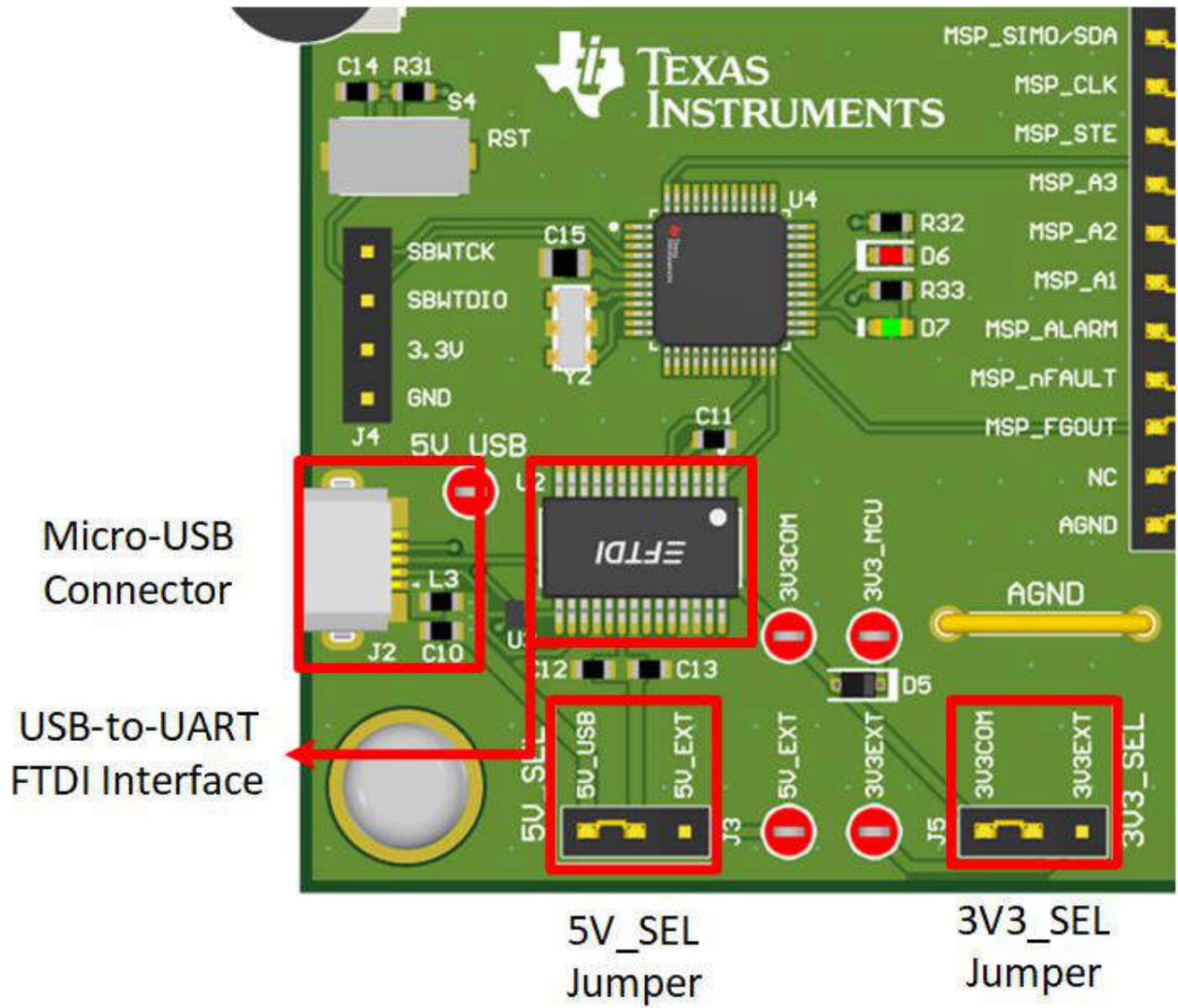

Figure 4-2. Micro-USB Connector and UART for MCF8316DEVM

## 5 MSP430FR2355 Microcontroller & User Interface

The MCF8316DEVM includes the MSP430FR2355 low-power MCU (as shown in [Figure 5-1](#)) to communicate via I2C with the MCF8316. The MSP430FR2355 is, by default, flashed with the firmware required to enable communication between the GUI and MCF8316.

To program the MSP430FR2355, an external MSP430 FET programmer, like the eZ-FET Debug Probe, must be connected to the Spy-Bi-Wire (SBW) interface connector J4. Many MSP430 LaunchPad™ provide an onboard eZ-FET Debug Probe that can be jumper-wired to the MCF8316DEVM to flash the firmware into the MSP430FR2355 microcontroller.

The Reset (RST) button at any time to reset and restart the MCU program. Two active-low LEDs, D6 and D7, can be used for debug purposes as well.

Finally, a shunt jumper bridge on the 32-pin connector J6 ties all signals between the microcontroller and MCF8316D. These jumpers can be inserted or removed as needed in order to isolate the microcontroller from the gate driver. This allows for microcontroller signal debugging or using the MCF8316DEVM as a standalone gate driver with an external microcontroller.

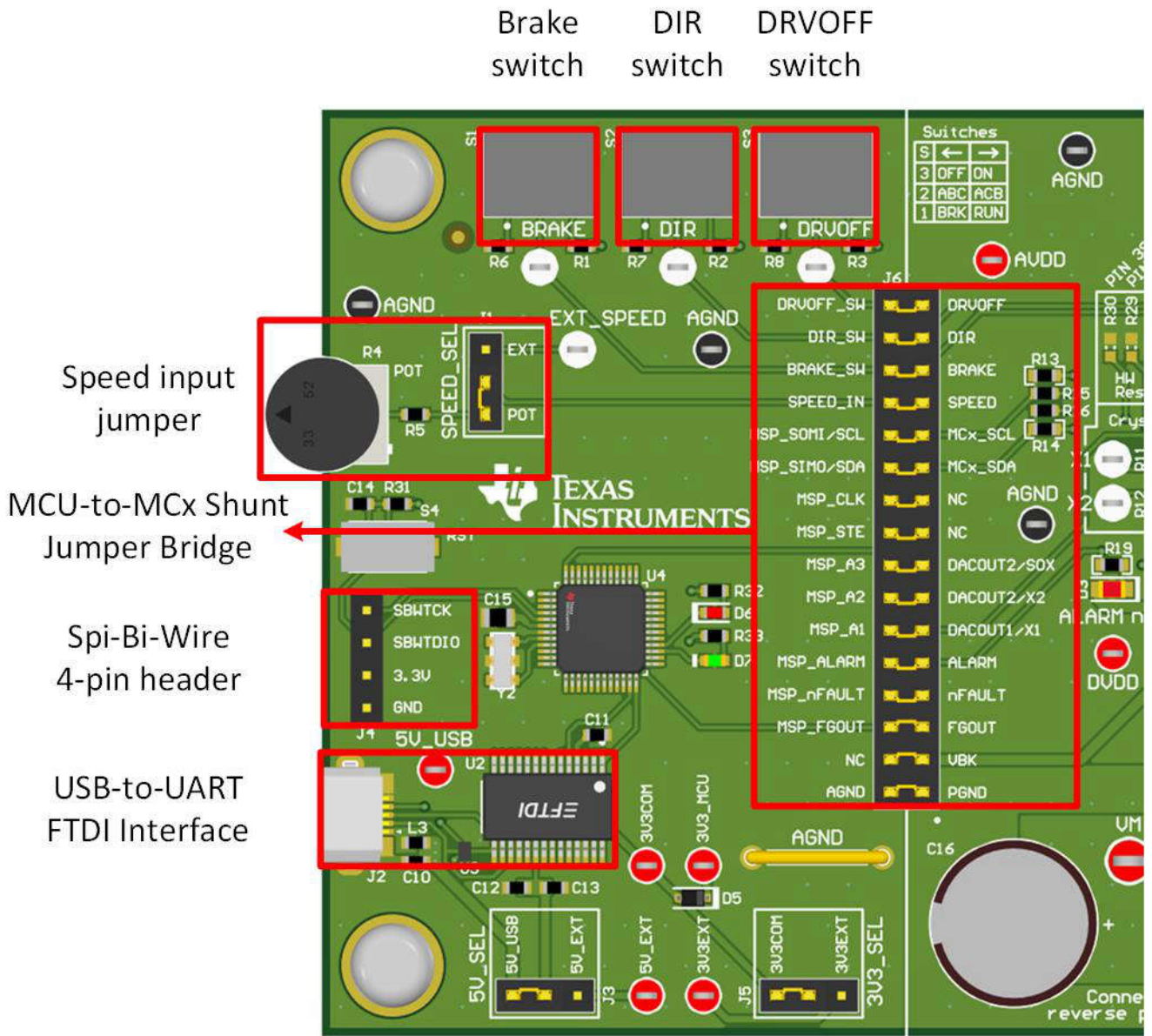

Figure 5-1. MSP430FR2355 MCU on MCF8316DEVM

## 6 LED Lights

The MCF8316DEVM has 6 status LEDs implemented that provide the status of power supplies and functionalities of the evaluation module. By default, the VM LED and 3.3V Buck LEDs will light up when the board is powered. [Table 6-1](#) shows LED descriptions including those that are on during power up in bold and [Figure 6-1](#) shows the locations of the LEDs.

**Table 6-1. Description of MCF8316DEVM LEDs**

Designator	Name	Color	Description
D1	Buck Regulator	Green	Internal buck regulator is voltage output
D2	nFAULT	Red	Lights up when fault condition has occurred on MCF8316D
D3	ALARM	Red	Lights up when alarm condition has occurred on MCF8316D
D4	VM	Green	Motor power is supplied to the board
D5	MSP_LED1	Red	Used for UART or debugging
D6	MSP_LED2	Red	Used for UART or debugging

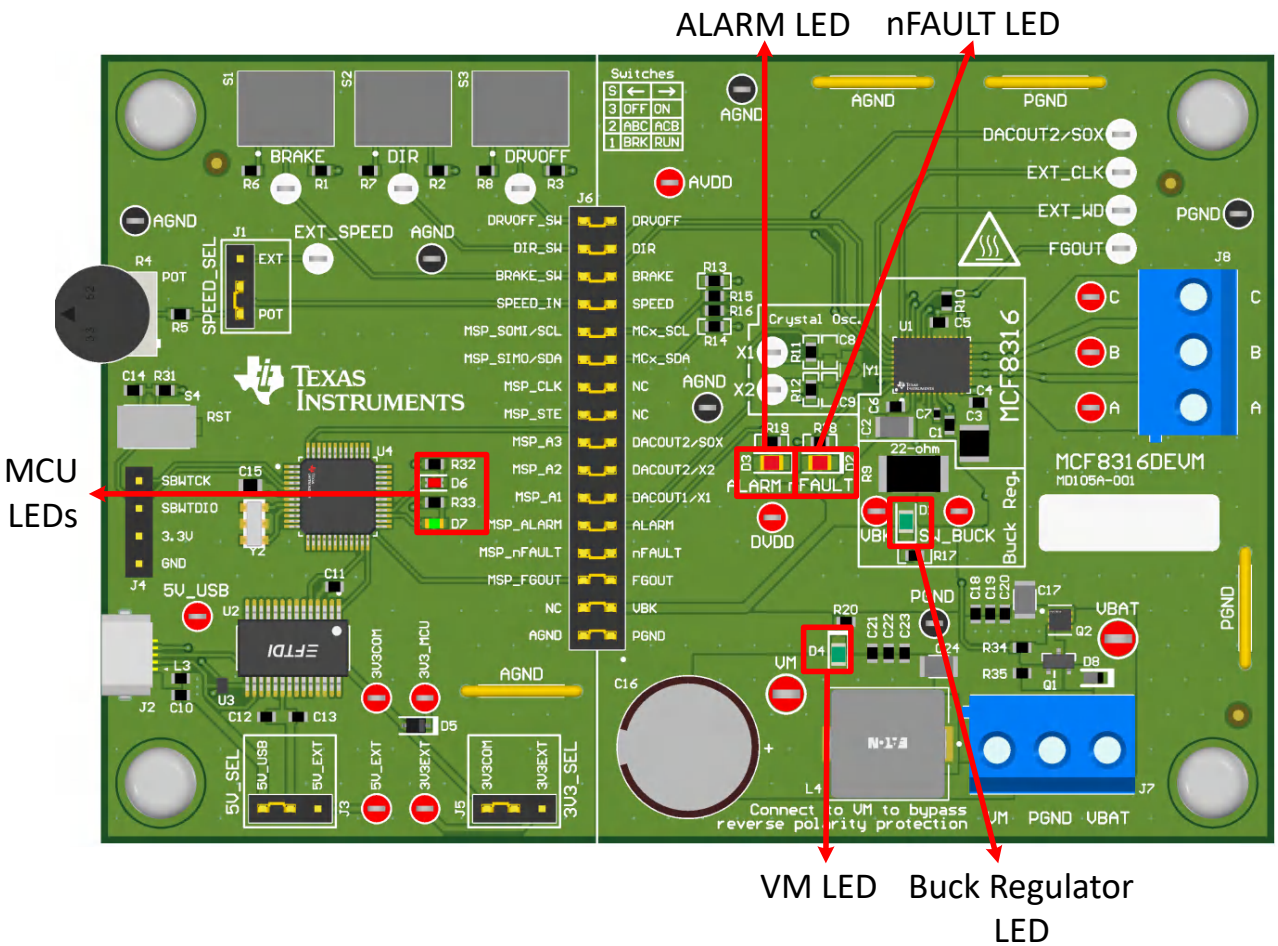

**Figure 6-1. MCF8316DEVM LED Locations**

## 7 User-Configurable Settings

The MCF8316DEVm includes a variety of user-selectable jumpers, switches, and resistors on the entirety of the evaluation board to configure settings. [Table 7-1](#) summarizes all of these configurable settings.

**Table 7-1. Description of User-Selectable Settings on MCF8316DEVm**

Designator	Setting Name	Description	Layer	Position	Function
L1/L2/R9	Buck Regulator mode	User populates L1, L2, or R9 to choose switching component for buck regulator	Top	L1 = 47uH Inductor	Inductor Mode
			Bottom	L2 = 22 $\mu$ H	Inductor Mode
			Bottom	R1 = 22 $\Omega$	Resistor Mode
J5	3V3_SEL	Select 3.3 V for MCU power	Top	J5 = 3V3EXT	External
				J5 = 3V3COM	From FTDI (30 mA)
J3	5V_SEL	Select 5 V for FTDI power	Top	J3 = 5V_EXT	External
				J3 = 5V_USB	From USB power (500 mA)
J1	SPEED_SEL	Selects SPEED input source	Top	J1 = EXT	External EXT_SPEED test point
				J1 = POT	From Potentiometer R4
				J1 is removed	Floating
J6	MSP to MCx Shunt jumper bridge	Connects signals from MCU and user switches to MCx8316A when jumpers are inserted	Top	DRVOFF_SW	DRVOFF
				DIR_SW	DIR
				BRAKE_SW	BRAKE
				SPEED_IN	SPEED
				MSP_SOMI/SCL	MCx_SCL
				MSP_SIMO/SDA	MCx_SDA
				MSP_CLK	NC
				MSP_STE	NC
				MSP_A3	DACOUT2/SOX
				MSP_A2	MCX_DACOUT2/X2
				MSP_A1	MCX_DACOUT1/X1
				MSP_ALARM	ALARM
				MSP_nFAULT	nFAULT
				MSP_FGOUT	FGOUT
NC	VBK				
AGND	AGND				
S1	BRAKE	Turns on all low-side MOSFETs	Top	Left	Brake enabled
				Right	Brake disabled
S2	DIR	Controls direction of motor	Top	Left	ABC
				Right	ACB
S3	DRVOFF	Disables gate drivers	Top	Left	MCF8316D enabled
				Right	MCF8316D disabled

## 8 Software

### 8.1 Firmware and GUI Application

The MCF8316DEVM includes a FTDI chip and MSP430FR2355 microcontroller which serve as a communication bridge between the host PC and the MCF8316 device for configuring various device settings and reading fault diagnostic information. Using this communication interface, the MCF8316DEVM can connect to the Motor Studio GUI to configure the MCF8316. The Motor Studio GUI simplifies the tuning process of the MCF8316 by offering guided tuning instructions, a virtual oscilloscope for real-time variable monitoring, and more. The latest version of the [Motor Studio GUI](#) can be downloaded on ti.com.

By default, the onboard MSP430FR2355 already contains the firmware needed to communicate with the Motor Studio GUI. If there is a firmware update or the GUI does not connect to the EVM, then the user must flash the firmware code into the MSP430 by following the steps outlined in [Section 8.4](#).

Flashing the firmware onto the EVM requires an external MSP430 LaunchPad™ that includes the eZ-FET Debug Probe and Code Composer Studio™ (CCS). The example in [Section 8.4](#) uses the MSP-EXP430FR2355 LaunchPad Development Kit to provide the eZ-FET Debug Probe.

### 8.2 Downloading and running Motor Studio

1. Connect the MCF8329RRYEVM as described in [Section 2.2](#).
2. Download the latest version of the [Motor Studio GUI](#).
3. Once the Motor Studio GUI is installed, run the Motor Studio GUI application.
4. Click the *Setup Now* button and follow the instructions to set up the EVM.
5. After setting up the MCF8316DEVM, click on *Quick Spin* to begin configuring the device.

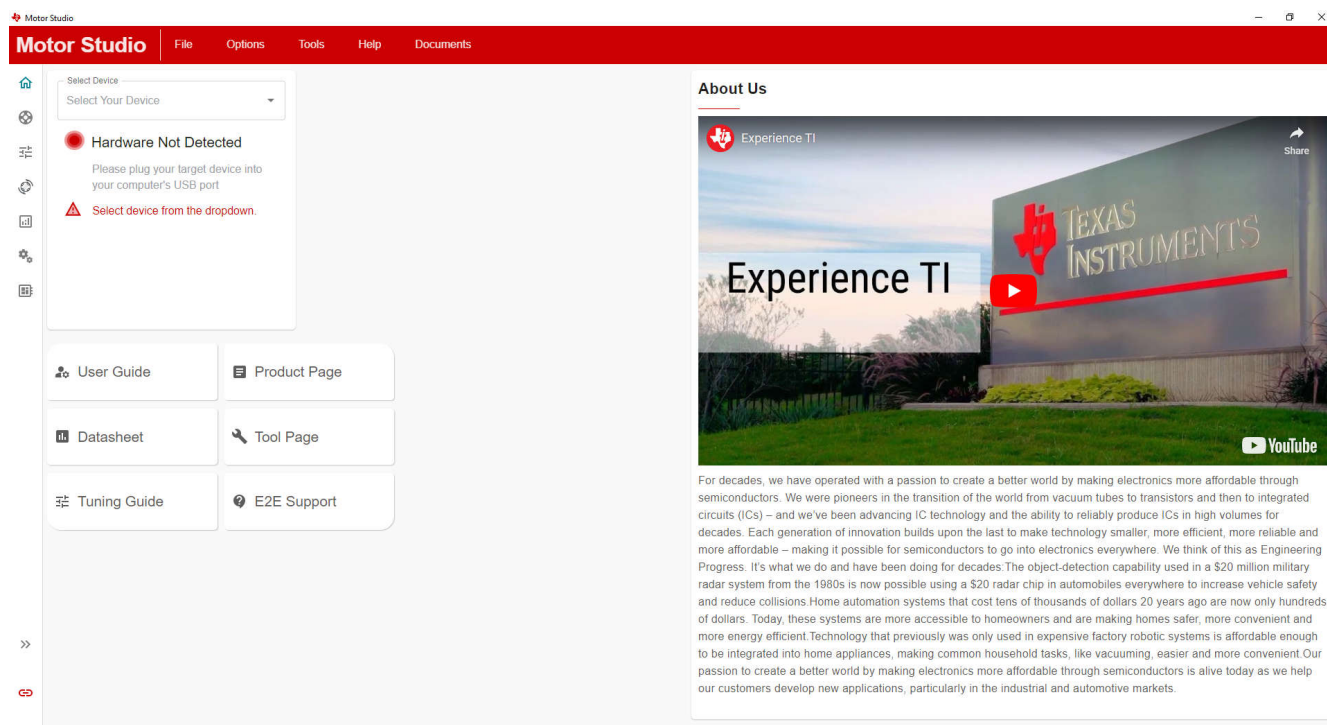

Figure 8-1. Motor Studio GUI Home Page

### 8.3 Downloading Code Composer Studio and Importing GUI Firmware

1. Download and extract the [Motor Studio firmware](#) to a location on your computer.
2. Download the latest version of [Code Composer Studio](#) to set up a folder in the directory C:\ti.
  - a. Accept all agreements, default install instructions, and select *Next* to proceed through the menus.
  - b. In the *Selected Components* window, make sure to check *MSP430 Low-Power MCUs* to install the required packages for the MSP430 Launchpad Evaluation Kits.
3. After installing, run CCS and select a folder or the default to use as the workspace to store any new projects. The location and naming convention can be changed based on the user's preference. Click the OK button to accept.
4. In CCS, click on the Project tab and select *Import CCS Projects*. Click on *Browse*.
5. Select the folder created in step 1 by extracting the Motor Studio firmware.
6. Import the project into your workspace as shown in [Figure 8-2](#)



```

1 /* --COPYRIGHT--.BSD
2 Copyright (c) 2018, Texas Instruments Incorporated
3 All rights reserved.
4
5 Redistribution and use in source and binary forms, with or without
6 modification, are permitted provided that the following conditions
7 are met:
8
9 Redistributions of source code must retain the above copyright
10 notice, this list of conditions and the following disclaimer.
11
12 Redistributions in binary form must reproduce the above copyright
13 notice, this list of conditions and the following disclaimer in the
14 documentation and/or other materials provided with the distribution.
15
16 Neither the name of Texas Instruments Incorporated nor the names of
17 its contributors may be used to endorse or promote products derived
18 from this software without specific prior written permission.
19
20 THIS SOFTWARE IS PROVIDED BY THE COPYRIGHT HOLDERS AND CONTRIBUTORS "AS IS"
21 AND ANY EXPRESS OR IMPLIED WARRANTIES, INCLUDING, BUT NOT LIMITED TO,
22 THE IMPLIED WARRANTIES OF MERCHANTABILITY AND FITNESS FOR A PARTICULAR
23 PURPOSE ARE DISCLAIMED. IN NO EVENT SHALL THE COPYRIGHT OWNER OR
24 CONTRIBUTORS BE LIABLE FOR ANY DIRECT, INDIRECT, INCIDENTAL, SPECIAL,
25 EXEMPLARY, OR CONSEQUENTIAL DAMAGES (INCLUDING, BUT NOT LIMITED TO,
26 PROCUREMENT OF SUBSTITUTE GOODS OR SERVICES; LOSS OF USE, DATA, OR PROFITS;
27 OR BUSINESS INTERRUPTION) HOWEVER CAUSED AND ON ANY THEORY OF LIABILITY,
28 WHETHER IN CONTRACT, STRICT LIABILITY, OR TORT (INCLUDING NEGLIGENCE OR
29 OTHERWISE) ARISING IN ANY WAY OUT OF THE USE OF THIS SOFTWARE,
30 EVEN IF ADVISED OF THE POSSIBILITY OF SUCH DAMAGE.
31 --/COPYRIGHT--/
32
33
34 // MSP430FR2355 firmware for compatibility with Motor Studio
35 //
36 // E. Chen
37 // Texas Instruments Inc.
38 // May 2018
39
40
41 #include <driverlib.h>
42 #include <stdint.h>
43 #include <stdbool.h>
44 #include <stdio.h>
45 #include <stdlib.h>
46 #include <string.h>
47 #include <jsmn.h>
48
49 /* Constants */
50 #define MAX_STR_LEN 256
51 #define INTER_BYTE_DELAY 2800 // at least 100 us
52 #define I2C_TIMEOUT 65535
    
```

**Figure 8-2. MSP430FR2355 Interface Firmware Code in Code Composer Studio**

### 8.4 Using eZ-FET to Program the Onboard MSP430FR2355

The eZ-FET Debug Probe on the MSP430FR2355 LaunchPad uses a Spy-Bi-Wire JTAG interface to program the MSP430FR2355 MCU on the MCF8316DEVM. Consult the [MSP430 LaunchPad Development Kits](#) for MSP430 LaunchPads that include an onboard eZ-FET Debug Probe.

1. Remove the GND, 3V3, SBWTDIO, and SBWTCK jumpers from the MSP430 LaunchPad.
2. Connect the top pins on the eZ-FET side of the LaunchPad of the GND, 3V3, SBWTDIO, and SBWTCK signals to their respective pins on J4 of the MCF8316DEVM as shown in [Table 8-1](#) and [Figure 8-3](#).
3. Connect a micro-USB cable to the MSP430 LaunchPad and the PC.
4. Click on the Build Project icon or CTRL+ B to ensure the project builds successfully. Accept any updates if needed from the Console.
5. Click on *Debug Project* to set up a debug session and press the *Play* button to run the code.
6. Stop the debug session, close Code Composer Studio, disconnect the Spy-by-Wire jumpers, and unplug the micro-USB cable from the MSP430 LaunchPad.

**Table 8-1. Spy-Bi-Wire Connections Needed to Program the MSP430FR2355**

MSP430 LaunchPad™ (eZ-FET Debug Probe Side) (J101)	MCF8316DEVM 4-pin Spi-Bi-Wire Header (J4)
GND	GND



**Table 8-1. Spy-Bi-Wire Connections Needed to Program the MSP430FR2355 (continued)**

MSP430 LaunchPad™ (eZ-FET Debug Probe Side) (J101)	MCF8316DEVM 4-pin Spi-Bi-Wire Header (J4)
3V3	3.3V
SBWTDIO	SBWTDIO
SBWTCK	SBWTCK

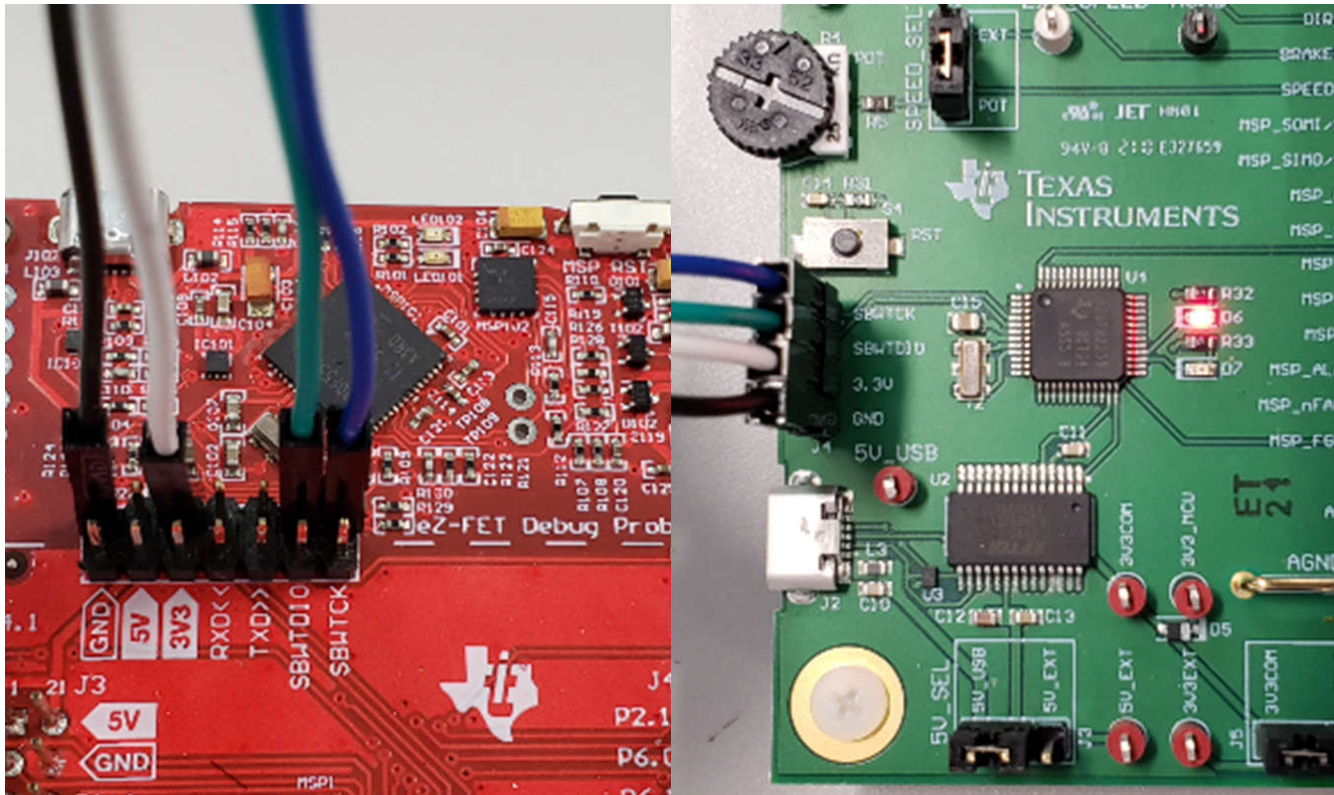

**Figure 8-3. MSP430 LaunchPad eZ-FET Debug Probe Connected to MSP430FR2355**

# 9 Hardware Design Files

## 9.1 Schematics

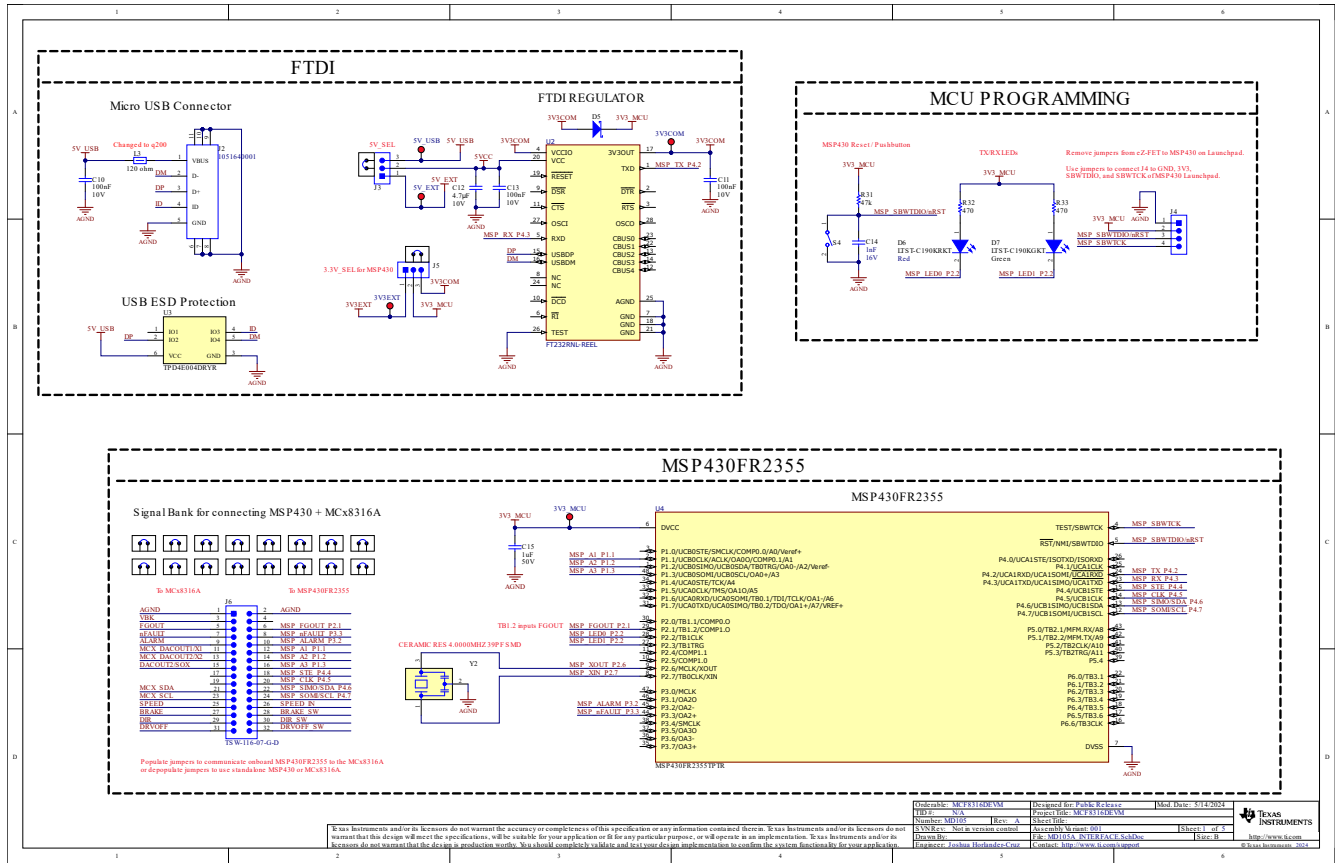

Figure 9-1. Interfaces

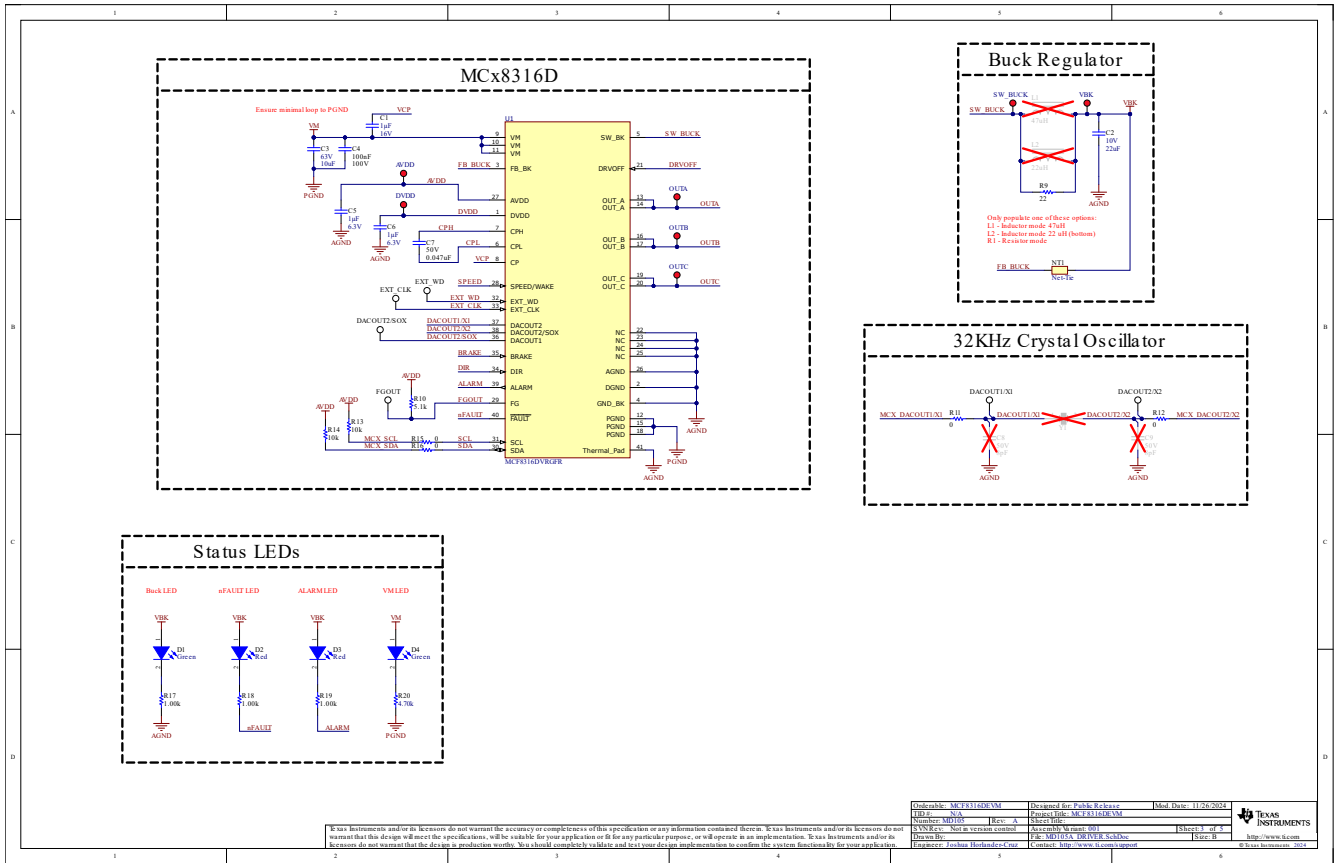

Figure 9-2. Driver

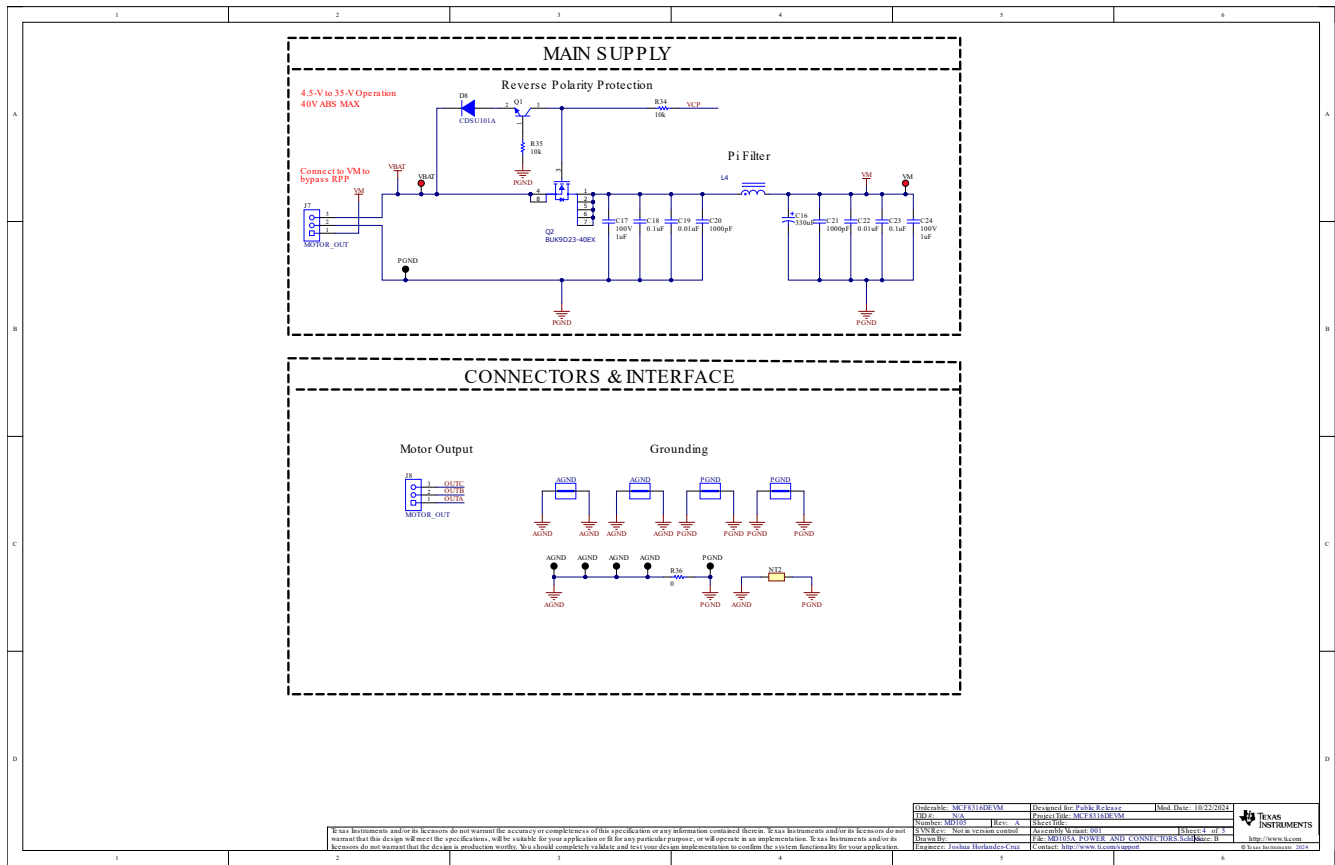

Figure 9-3. Power and Connectors

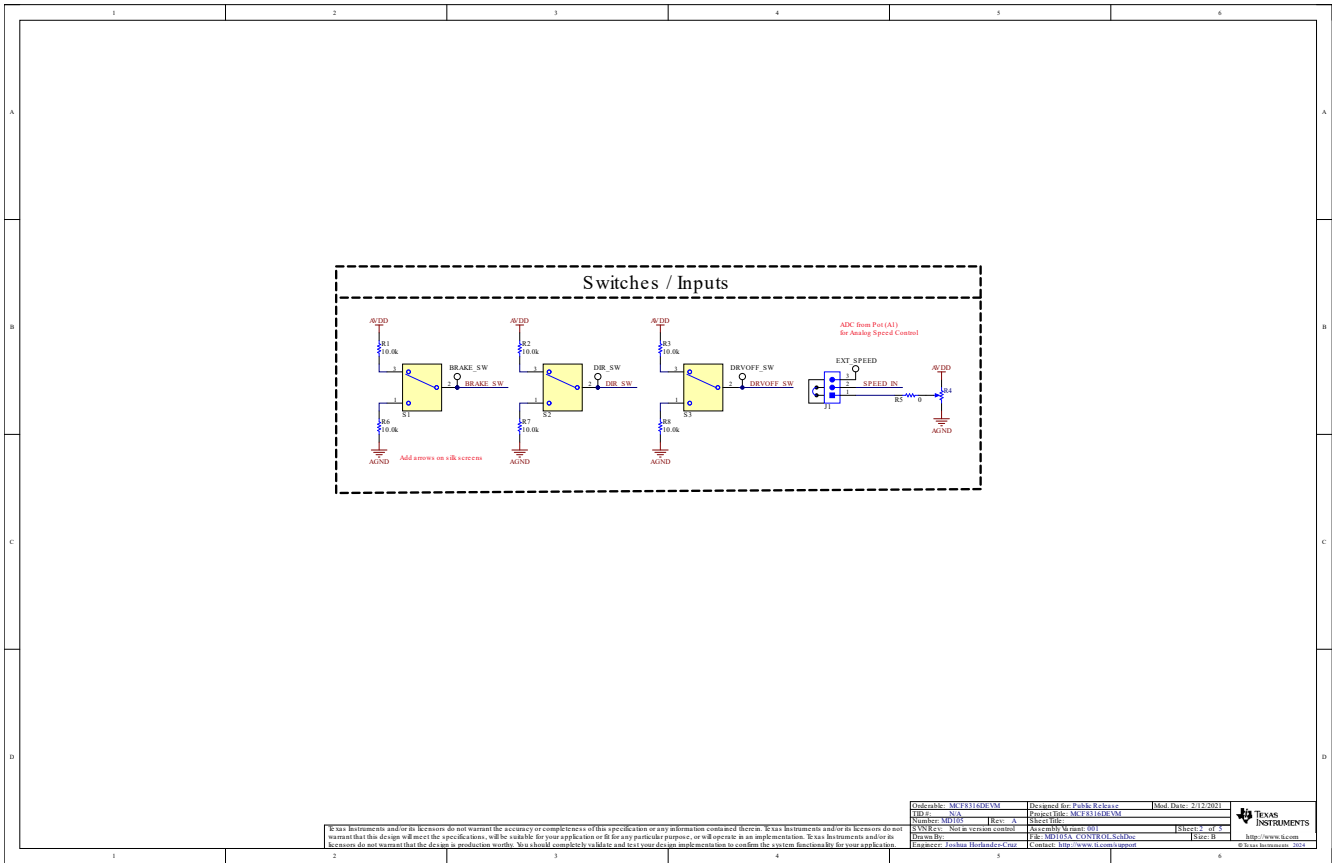

Figure 9-4. Control

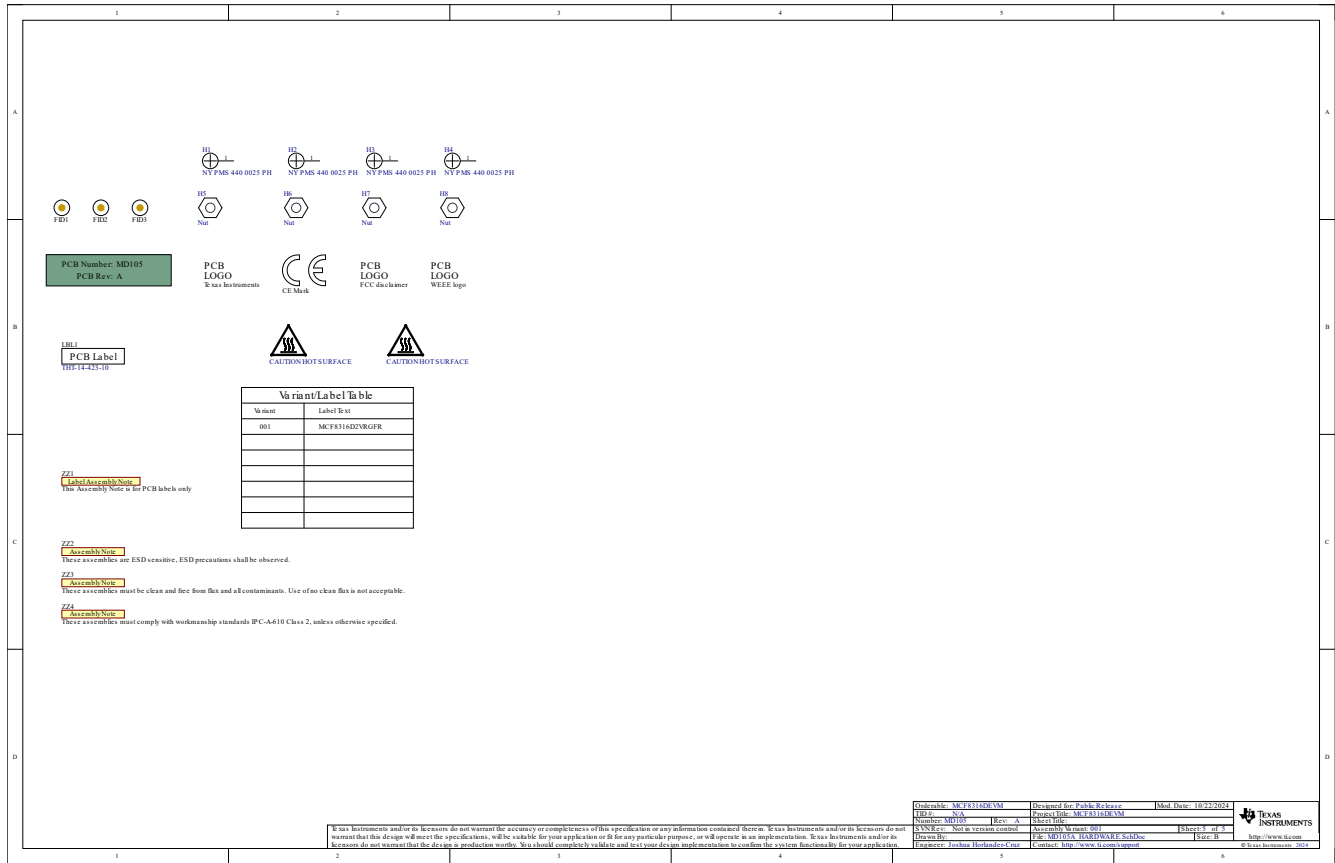
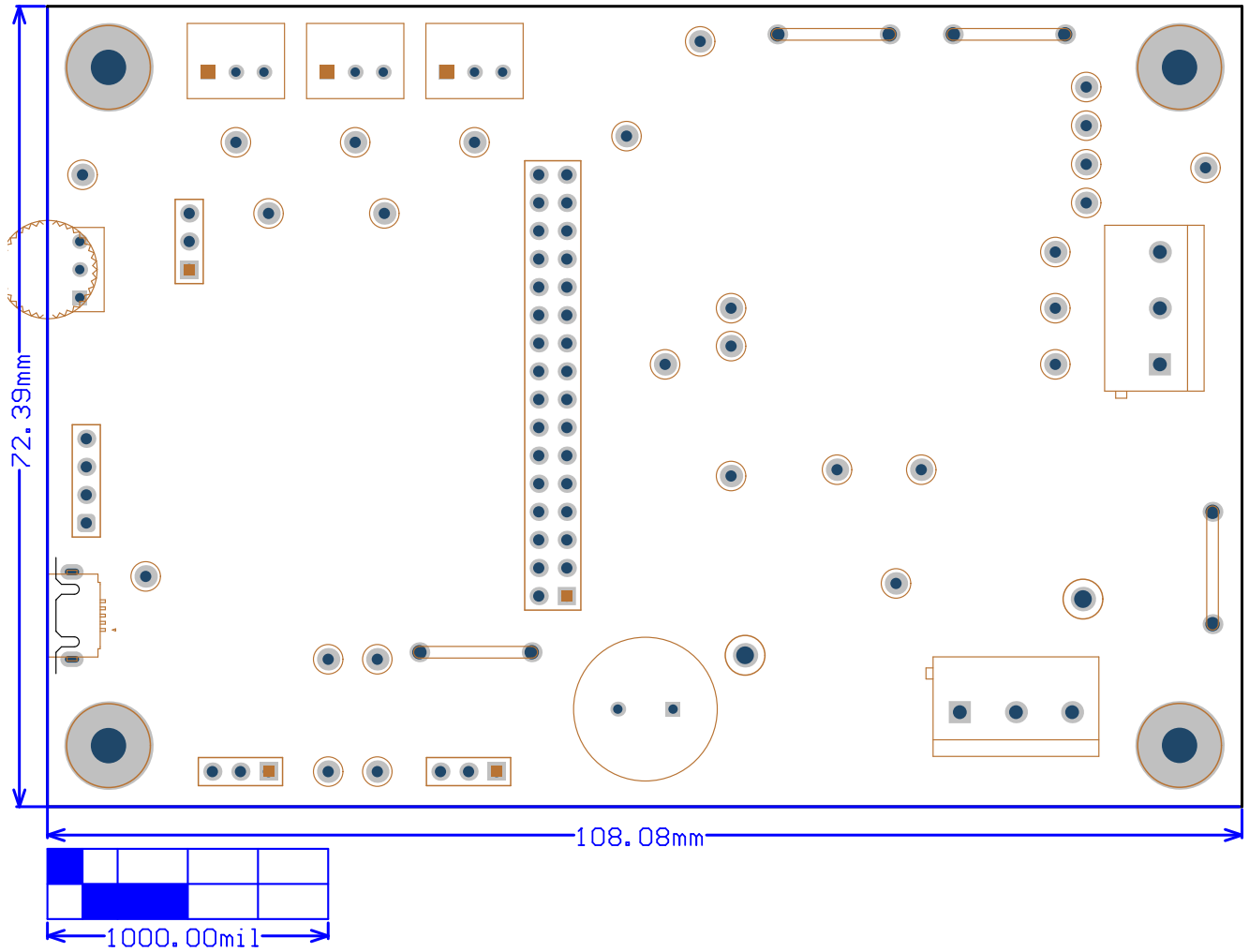

Figure 9-5. Hardware

## 9.2 PCB Layouts



**Figure 9-6. EVM Board Dimensions**

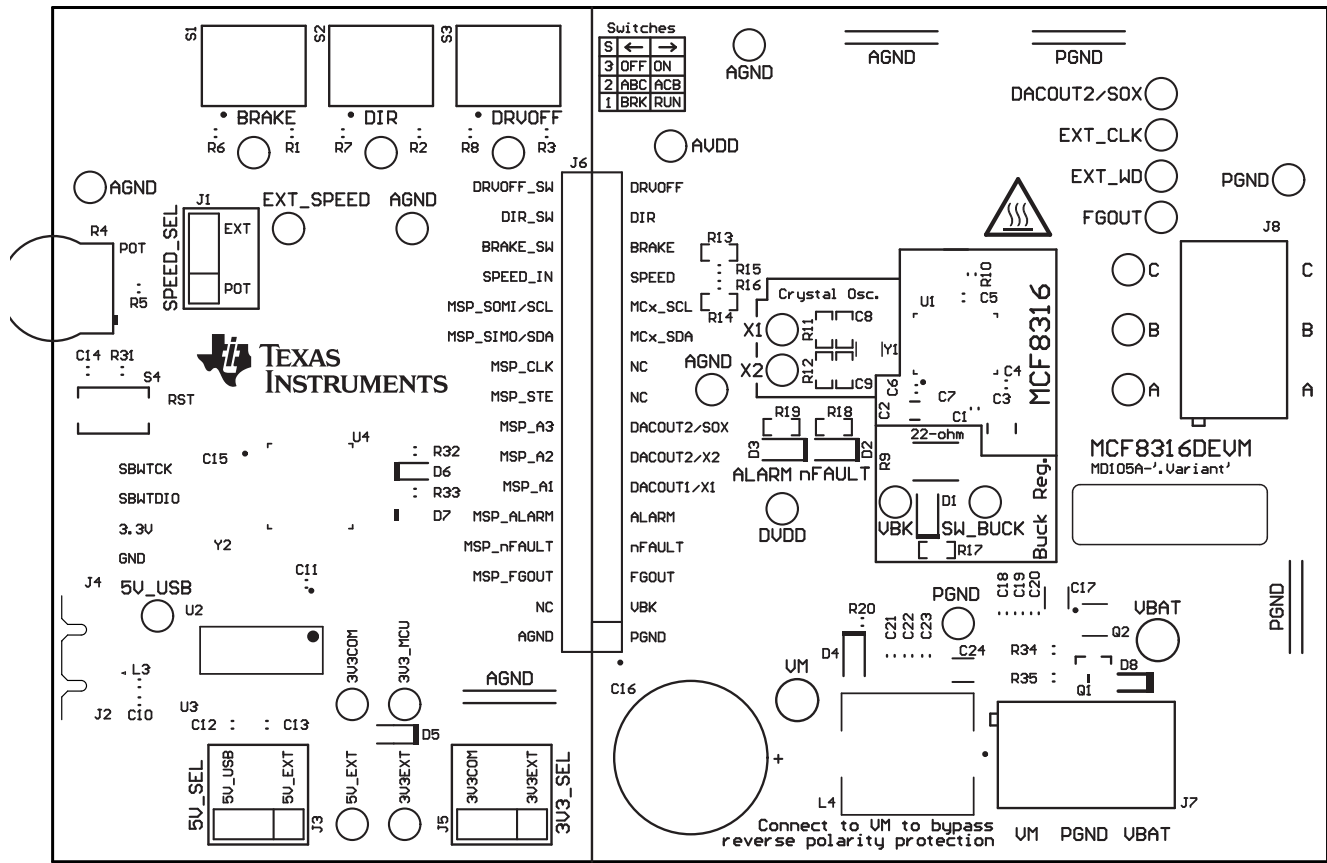
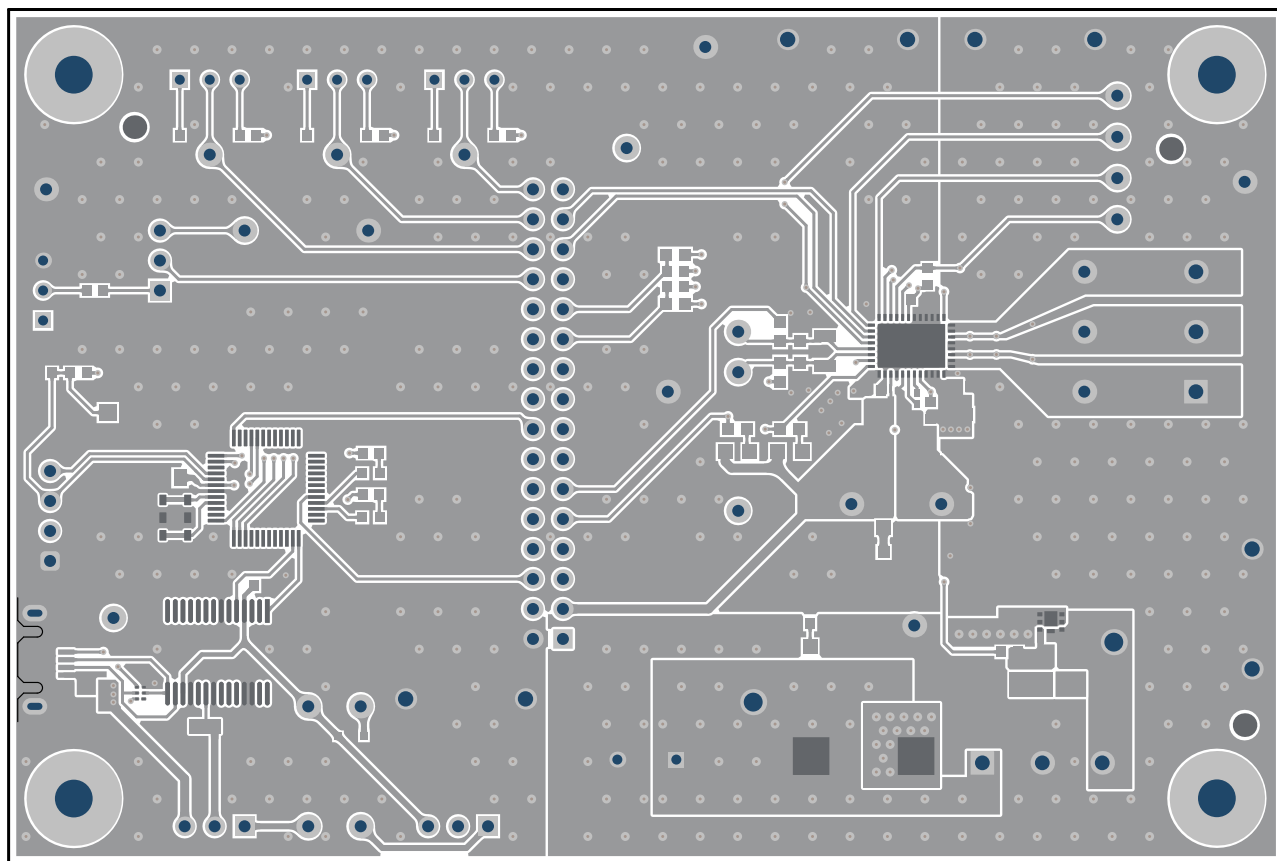
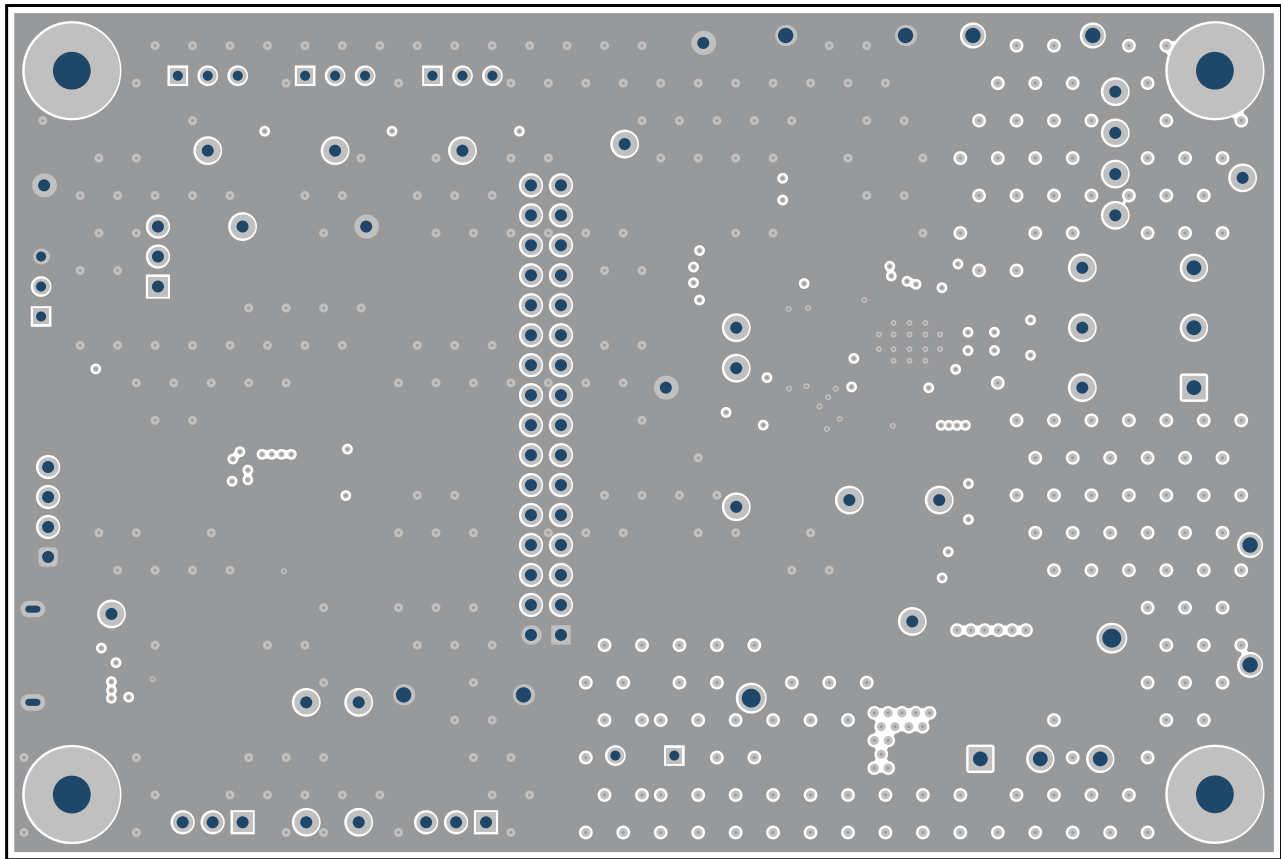

Figure 9-7. EVM Top Overlay

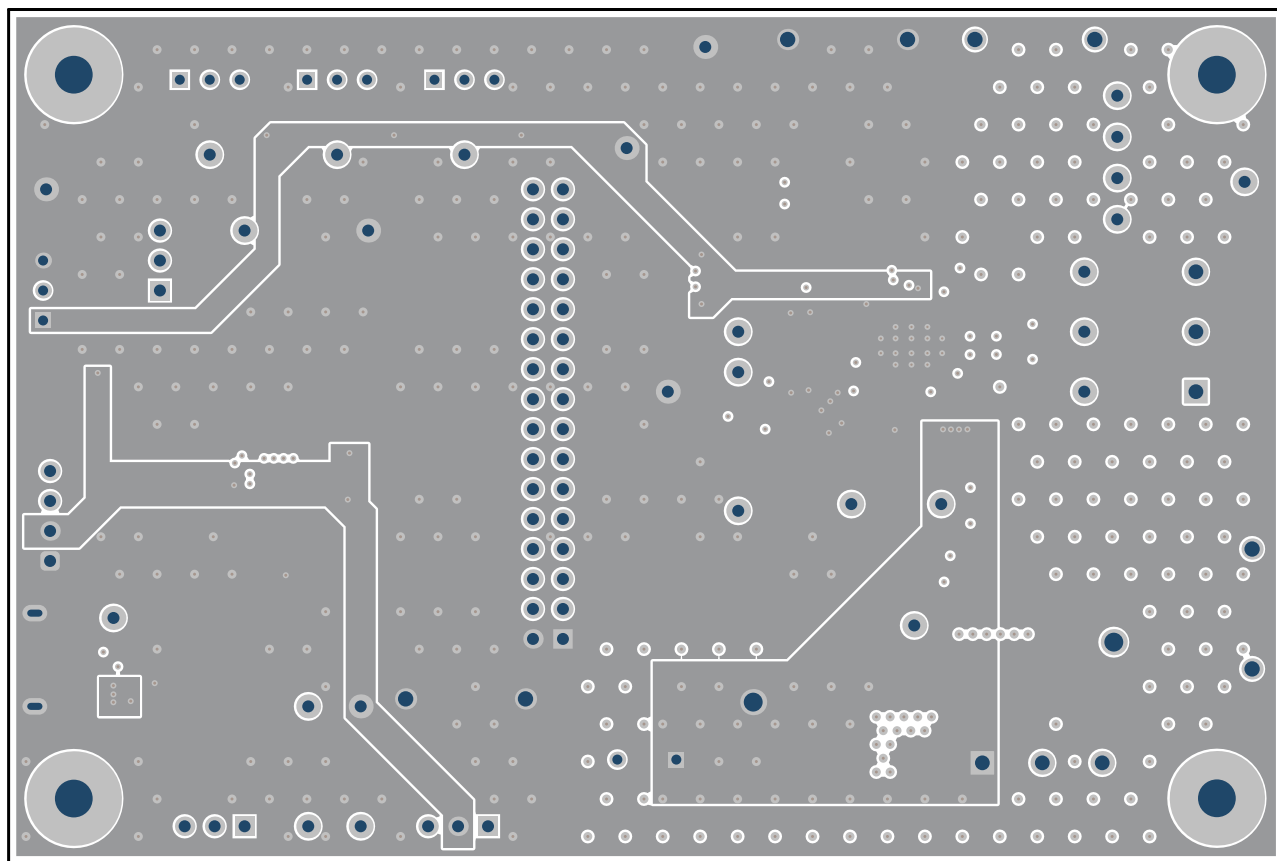



**Figure 9-8. EVM Top Layer**



**Figure 9-9. EVM Signal Layer 1**



**Figure 9-10. EVM Signal Layer 2**

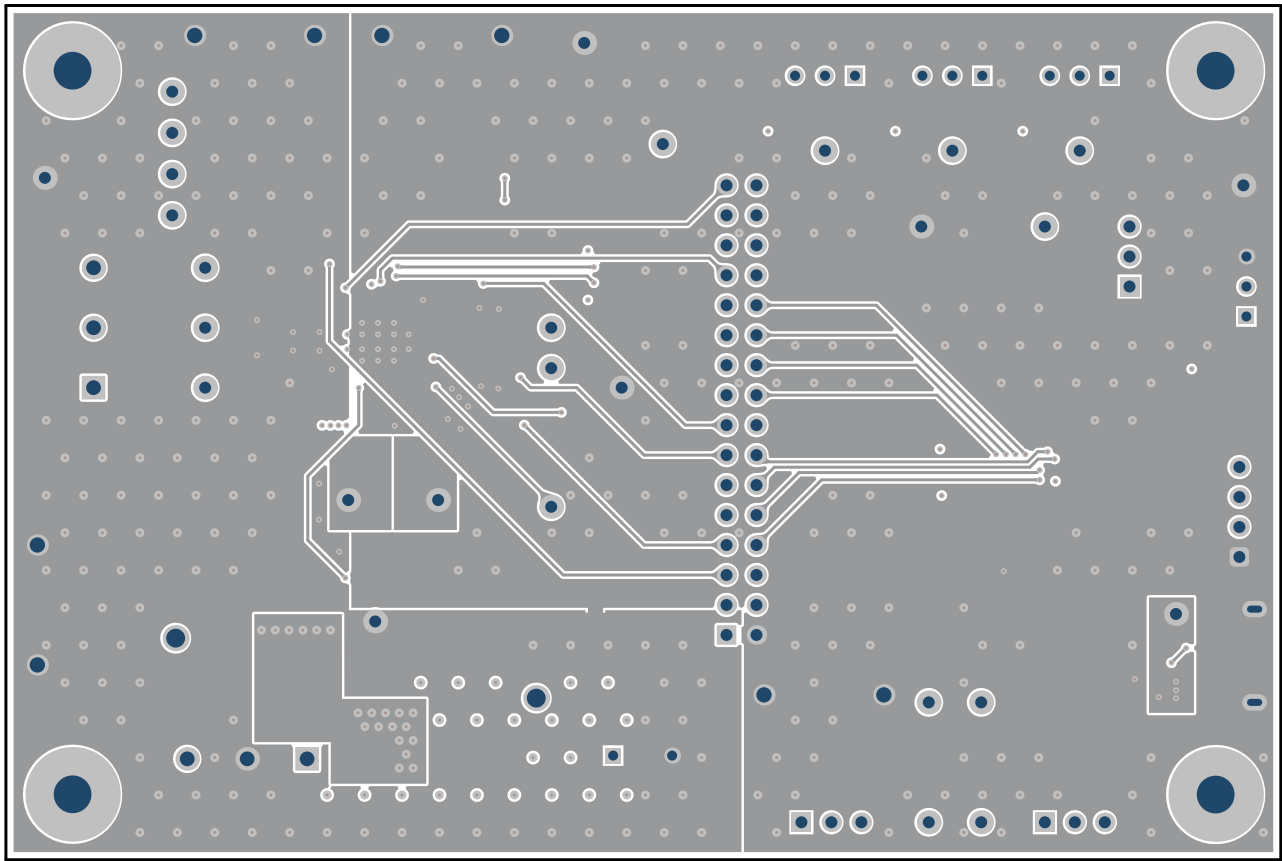

**Figure 9-11. EVM Bottom Layer**

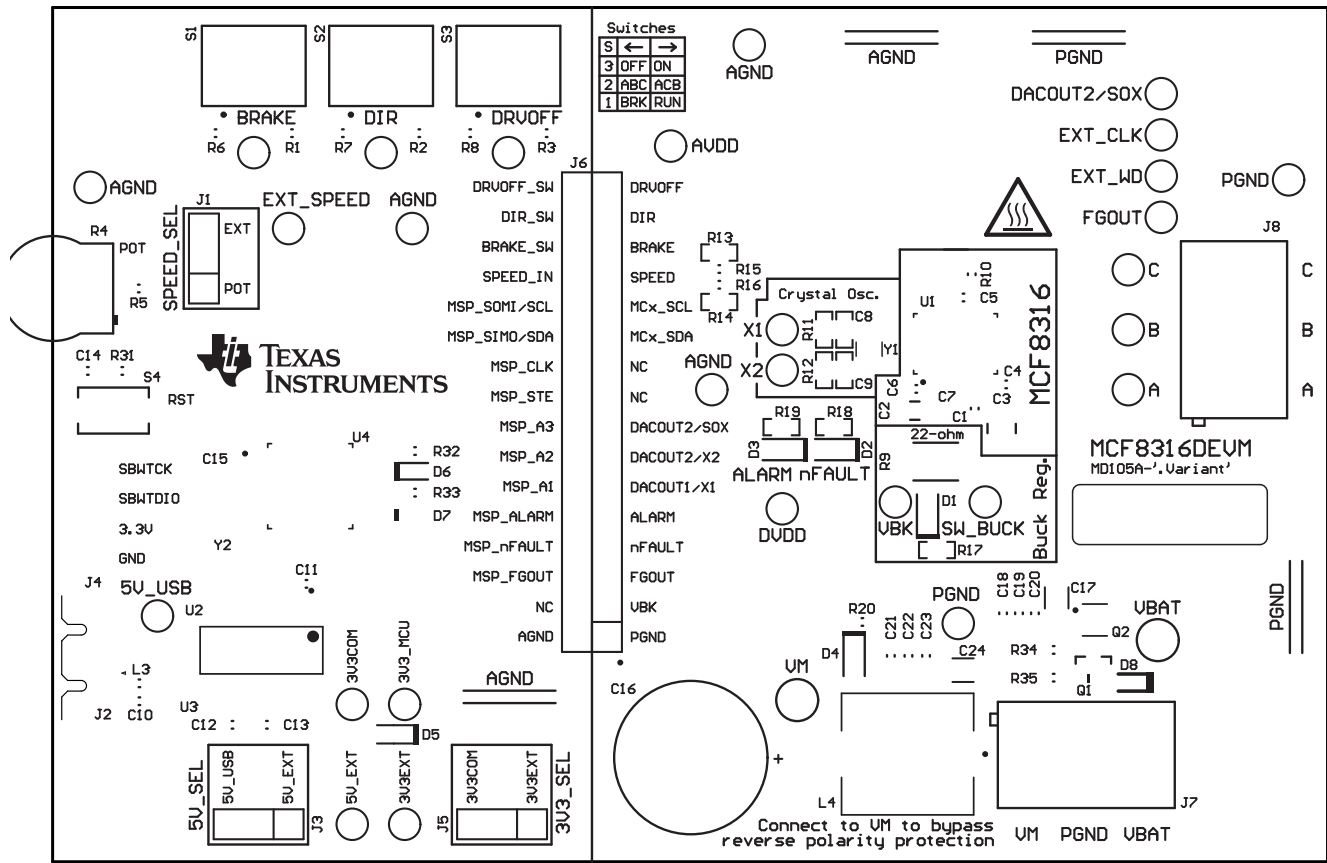

Figure 9-12. EVM Bottom Overlay

### 9.3 Bill of Materials (BOM)

Designator	Quantity	Value	Description	PackageReference	PartNumber	Manufacturer
C1	1	1uF	CAP, CERM, 1µF, 16V,+/- 10%, X7R, AEC-Q200 Grade 1, 0603	603	EMK107B7105KAHT	Taiyo Yuden
C2	1	22uF	CAP, CERM, 22uF, 10V, +/- 10%, X7R, 1206	1206	GRM31CR71A226KE15L	MuRata
C3	1	10uF	CAP, CERM, 10uF, 63V, +/- 10%, X7R, 1210	1210	GRM32ER71J106KA12L	MuRata
C4	1	0.1uF	CAP, CERM, 0.1µF, 100V,+/- 10%, X7R, 0603	603	0603BB104KW101	Passive Plus

Designator	Quantity	Value	Description	PackageReference	PartNumber	Manufacturer
C5, C6	2	1uF	CAP, CERM, 1μF, 6.3V, +/- 10%, X7R, AEC-Q200 Grade 1, 0603	603	C0603C105K9RA CAUTO	Kemet
C7	1	0.047uF	CAP, CERM, 0.047uF, 50V, +/- 10%, X7R, 0402	402	C1005X7R1H473 K050BB	TDK
C10, C11, C13	3	0.1uF	CAP, CERM, 0.1uF, 10V, +/- 10%, X7R, 0603	603	0603ZC104KAT2A	AVX
C12	1	4.7uF	CAP, CERM, 4.7uF, 10V, +/- 20%, X7R, 0603	603	GRM188Z71A475 ME15D	MuRata
C14	1	1000pF	CAP, CERM, 1000pF, 16V, +/- 10%, X7R, 0603	603	8.85012E+11	Würth Elektronik
C15	1	1uF	CAP, CERM, 1uF, 50V, +/- 10%, X7R, 0805	805	8.85012E+11	Würth Elektronik
C16	1	330uF	CAP, AL, 330uF, 63V, +/- 20%, AEC-Q200 Grade 2, TH	D12.5xL20mm	ELXZ630ELL331 MK20S	Chemi-Con
C17, C24	2	1uF	CAP, CERM, 1uF, 100V, +/- 10%, X7R, 1206	1206	CL31B105KCHNN NE	Samsung
C18, C23	2	0.1uF	CAP, CERM, 0.1uF, 100V, +/- 10%, X7S, AEC-Q200 Grade 1, 0603	603	CGA3E3X7S2A10 4K080AB	TDK
C19, C22	2	0.01uF	CAP, CERM, 0.01uF, 100V, +/- 10%, X7R, AEC-Q200 Grade 1, 0603	603	CGA3E2X7R2A10 3K080AA	TDK
C20, C21	2	1000pF	CAP, CERM, 1000pF, 100V, +/- 10%, X7R, AEC-Q200 Grade 1, 0603	603	CGA3E2X7R2A10 2K080AA	TDK
D1, D4	2	Green	LED, Green, SMD	LED_0805	LTST-C170KGKT	Lite-On
D2, D3	2	Red	LED, Red, SMD	Red 0805 LED	LTST-C170KRKT	Lite-On
D5	1	40V	Diode, Schottky, 40V, 0.75A, AEC-Q101, SOD-323	SOD-323	BAT165E6327HT SA1	Infineon Technologies
D6	1	Red	LED, Red, SMD	Red LED, 1.6x0.8x0.8mm	LTST-C190KRKT	Lite-On

Designator	Quantity	Value	Description	PackageReference	PartNumber	Manufacturer
D7	1	Green	LED, Green, SMD	1.6x0.8x0.8mm	LTST-C190KGKT	Lite-On
D8	1	90V	Diode, Switching, 90V, 0.1A, SOD-523F	SOD-523F	CDSU101A	Comchip Technology
FID1, FID2, FID3	3		Fiducial mark. There is nothing to buy or mount.	N/A	N/A	N/A
H1, H2, H3, H4	4		Machine Screw, Round, #4-40 x 1/4, Nylon, Philips panhead	Screw	NY PMS 440 0025 PH	B&F Fastener Supply
H5, H6, H7, H8	4		Standoff, Hex, 0.5"L #4-40 Nylon	Standoff	1902C	Keystone
J1, J3, J5	3		Header, 100mil, 3x1, Gold, TH	PBC03SAAN	PBC03SAAN	Sullins Connector Solutions
J2	1		Receptacle, USB 2.0, Micro B, 5 Position, R/A, SMT	Receptacle, USB 2.0, Micro B, 5 Pos, 0.65mm Pitch, R/A, SMT	1051640001	Molex
J4	1		Header, 100mil, 4x1, Gold, TH	4x1 Header	TSW-104-07-G-S	Samtec
J6	1		Header, 100mil, 16x2, Gold, TH	16x2 Header	TSW-116-07-G-D	Samtec
J7, J8	2		Terminal Block, 5.08mm, 3x1, Brass, TH	3x1 5.08mm Terminal Block	ED120/3DS	On-Shore Technology
L3	1		Inductor, Ferrite Bead, Ferrite, 3A, 120ohm, AEC- Q200 Grade 1, SMD	603	BLM18SG121TZ1 D	MuRata
L4	1	1uH	1µH Shielded - Inductor 19A 3.1mOhm Max Nonstandard	SMD2	HCM1A1104V2-1 R0-R	Eaton
LBL1	1			PCB Label 0.650 x 0.200 inch	THT-14-423-10	Brady
Q1	1	80V	Transistor, NPN, 80V, 1.5A, AEC- Q101, SOT-23	SOT-23	FMMT620TA	Diodes Inc.
Q2	1		N-Channel 40V 8A (Ta) 15W (Tc) Surface Mount DFN2020MD-6	SOT1220	BUK9D23-40EX	Nexperia
R1, R2, R3, R6, R7, R8	6	10.0k	RES, 10.0k, 0.05%, 0.1W, AEC-Q200 Grade 0, 0603	603	ERA-3ARW103V	Panasonic

Designator	Quantity	Value	Description	PackageReference	PartNumber	Manufacturer
R4	1	25 kohm	Trimmer Potentiometer, 25kohm, 0.5W, TH	9.53x8.89mm	3352T-1-253LF	Bourns
R5, R11, R12, R15, R16	5	0	RES, 0, 5%, 0.1 W, AEC-Q200 Grade 0, 0603	603	ERJ-3GEY0R00V	Panasonic
R9	1	22	RES, 22, 5%, 1.5 W, AEC-Q200 Grade 0, 2512	2512	CRCW251222R0J NEGHP	Vishay-Dale
R10	1	5.1k	RES, 5.1 k, 5%, 0.1 W, AEC-Q200 Grade 0, 0603	603	CRCW06035K10J NEA	Vishay-Dale
R13, R14, R34, R35	4	10k	RES, 10 k, 5%, 0.1 W, AEC-Q200 Grade 0, 0603	603	CRCW060310K0J NEA	Vishay-Dale
R17, R18, R19	3	1.00k	RES, 1.00k, 1%, 0.1W, 0603	603	RC0603FR-071KL	Yageo
R20	1	4.70k	RES, 4.70k, 0.1%, 0.1W, 0603	603	RT0603BRD074K 7L	Yageo America
R31	1	47k	RES, 47k, 5%, 0.1W, 0603	603	RC0603JR-0747K L	Yageo
R32, R33	2	470	RES, 470, 5%, 0.1W, 0603	603	RC0603JR-07470 RL	Yageo
R36	1	0	RES, 0, 5%, 0.25W, AEC-Q200 Grade 0, 1206	1206	RCA12060000ZS EA	Vishay-Dale
S1, S2, S3	3		SWITCH TOGGLE SPDT 0.4VA 28V	6.8x23.1x8.8mm	B12AP	NKK Switches
S4	1		Switch, Tactile, SPST, 12V, SMD	SMD, 6x3.9mm	4.34121E+11	Würth Elektronik
SH-J1, SH-J2, SH-J3, SH-J4, SH-J5, SH-J6, SH-J7, SH-J8, SH-J9, SH-J10, SH-J11, SH-J12, SH-J13, SH-J14, SH-J15, SH-J16, SH-J17, SH-J18, SH-J19	19	1x2	Shunt, 100mil, Gold plated, Black	Shunt	SNT-100-BK-G	Samtec
TP1, TP2, TP3, TP4, TP12, TP13, TP14, TP15, TP16, TP17	10		Test Point, Miniature, White, TH	White Miniature Testpoint	5002	Keystone



Designator	Quantity	Value	Description	PackageReference	PartNumber	Manufacturer
TP5, TP6, TP7, TP8, TP9, TP10, TP11, TP18, TP19, TP20, TP21, TP22	12		Test Point, Miniature, Red, TH	Red Miniature Testpoint	5000	Keystone
TP23, TP24	2		Test Point, Compact, Red, TH	Red Compact Testpoint	5005	Keystone
TP25, TP30, TP31, TP32, TP33, TP34	6		Test Point, Miniature, Black, TH	Black Miniature Testpoint	5001	Keystone
TP26, TP27, TP28, TP29	4		1mm Uninsulated Shorting Plug, 10.16mm spacing, TH	Shorting Plug, 10.16mm spacing, TH	D3082-05	Harwin
U1	1		MCF8316DVRGFR	VQFN40	MCF8316DVRGFR	Texas Instruments
U2	1		UART Interface IC USB Full Speed to Serial UART IC, Includes Oscillator and EEPROM, SSOP-28	SSOP28	FT232RNL-REEL	FTDI
U3	1		4-Channel ESD Protection Array for High-Speed Data Interfaces, DRY0006A (USON-6)	DRY0006A	TPD4E004DRYR	Texas Instruments
U4	1		CPU16 MSP430™ FRAM Microcontroller IC 16-Bit 24MHz 32KB (32K x 8) FRAM 48-LQFP (7x7)	LQFP48	MSP430FR2355T PTR	Texas Instruments
Y2	1		Resonator, 4MHz, 39pF, AEC-Q200 Grade 1, SMD	4.5x1.2x2mm	CSTCR4M00G55 B-R0	MuRata

## 10 Additional Information

### Trademarks

LaunchPad™ and Code Composer Studio™ are trademarks of Texas Instruments.  
All trademarks are the property of their respective owners.

## 11 Revision History

NOTE: Page numbers for previous revisions may differ from page numbers in the current version.

DATE	REVISION	NOTES
August 2021	*	Initial Release

## IMPORTANT NOTICE AND DISCLAIMER

TI PROVIDES TECHNICAL AND RELIABILITY DATA (INCLUDING DATA SHEETS), DESIGN RESOURCES (INCLUDING REFERENCE DESIGNS), APPLICATION OR OTHER DESIGN ADVICE, WEB TOOLS, SAFETY INFORMATION, AND OTHER RESOURCES "AS IS" AND WITH ALL FAULTS, AND DISCLAIMS ALL WARRANTIES, EXPRESS AND IMPLIED, INCLUDING WITHOUT LIMITATION ANY IMPLIED WARRANTIES OF MERCHANTABILITY, FITNESS FOR A PARTICULAR PURPOSE OR NON-INFRINGEMENT OF THIRD PARTY INTELLECTUAL PROPERTY RIGHTS.

These resources are intended for skilled developers designing with TI products. You are solely responsible for (1) selecting the appropriate TI products for your application, (2) designing, validating and testing your application, and (3) ensuring your application meets applicable standards, and any other safety, security, regulatory or other requirements.

These resources are subject to change without notice. TI grants you permission to use these resources only for development of an application that uses the TI products described in the resource. Other reproduction and display of these resources is prohibited. No license is granted to any other TI intellectual property right or to any third party intellectual property right. TI disclaims responsibility for, and you will fully indemnify TI and its representatives against, any claims, damages, costs, losses, and liabilities arising out of your use of these resources.

TI's products are provided subject to [TI's Terms of Sale](#) or other applicable terms available either on [ti.com](https://www.ti.com) or provided in conjunction with such TI products. TI's provision of these resources does not expand or otherwise alter TI's applicable warranties or warranty disclaimers for TI products.

TI objects to and rejects any additional or different terms you may have proposed.

Mailing Address: Texas Instruments, Post Office Box 655303, Dallas, Texas 75265  
Copyright © 2024, Texas Instruments Incorporated