

© COPYRIGHT 2021 TEXAS INSTRUMENTS
UN-PUBLISHED. ALL RIGHTS RESERVED.

REVISIONS		DATE	BY
REV	DESCRIPTION		
A	ECO 2191771: INITIAL RELEASE	1/4/2021	BMH

NOTES UNLESS OTHERWISE SPECIFIED:

- 1 DIE PARALLELISM TOLERANCE APPLIES TO DMD ACTIVE ARRAY ONLY.
- 2 ROTATION ANGLE OF DMD ACTIVE ARRAY IS A REFINEMENT OF THE LOCATION TOLERANCE AND HAS A MAXIMUM ALLOWED VALUE OF 0.6 DEGREES.
- 3 BOUNDARY MIRRORS SURROUNDING THE DMD ACTIVE ARRAY.
- 4 NOTCH DIMENSIONS ARE DEFINED BY UPPERMOST LAYERS OF CERAMIC, AS SHOWN IN SECTION A-A.
- 5 ENCAPSULANT TO BE CONTAINED WITHIN DIMENSIONS SHOWN IN VIEW C (SHEET 2). NO ENCAPSULANT IS ALLOWED ON TOP OF THE WINDOW.
- 6 ENCAPSULANT NOT TO EXCEED THE HEIGHT OF THE WINDOW.
- 7 DATUM B IS DEFINED BY A DIA. 2.5 PIN, WITH A FLAT ON THE SIDE FACING TOWARD THE CENTER OF THE ACTIVE ARRAY, AS SHOWN IN VIEW B (SHEET 2).
- 8 WHILE ONLY THE THREE DATUM A TARGET AREAS A1, A2, AND A3 ARE USED FOR MEASUREMENT, ALL 4 CORNERS SHOULD BE CONTACTED, INCLUDING E1, TO SUPPORT MECHANICAL LOADS.

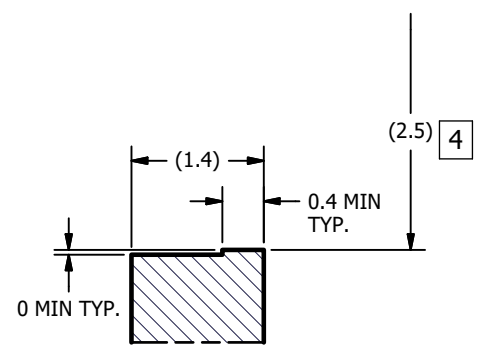
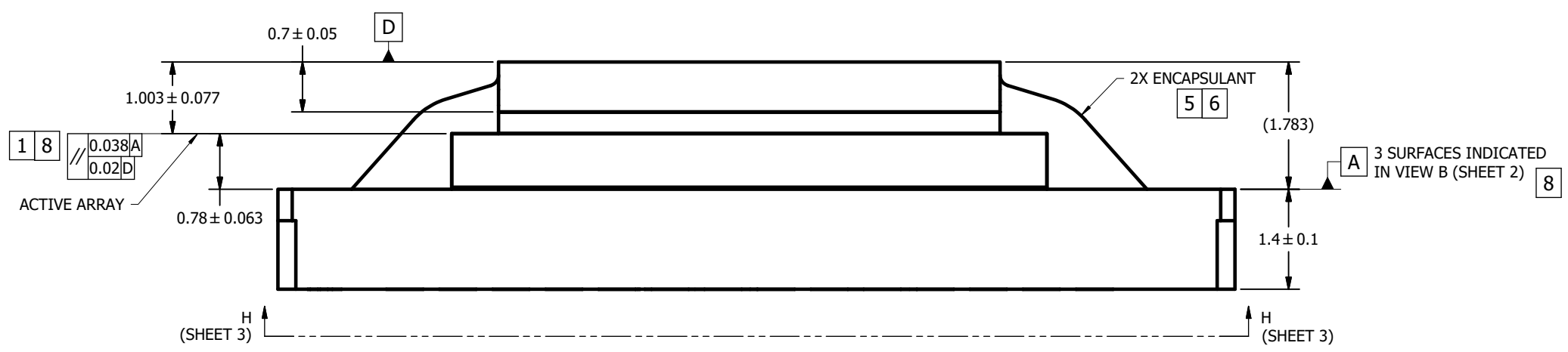
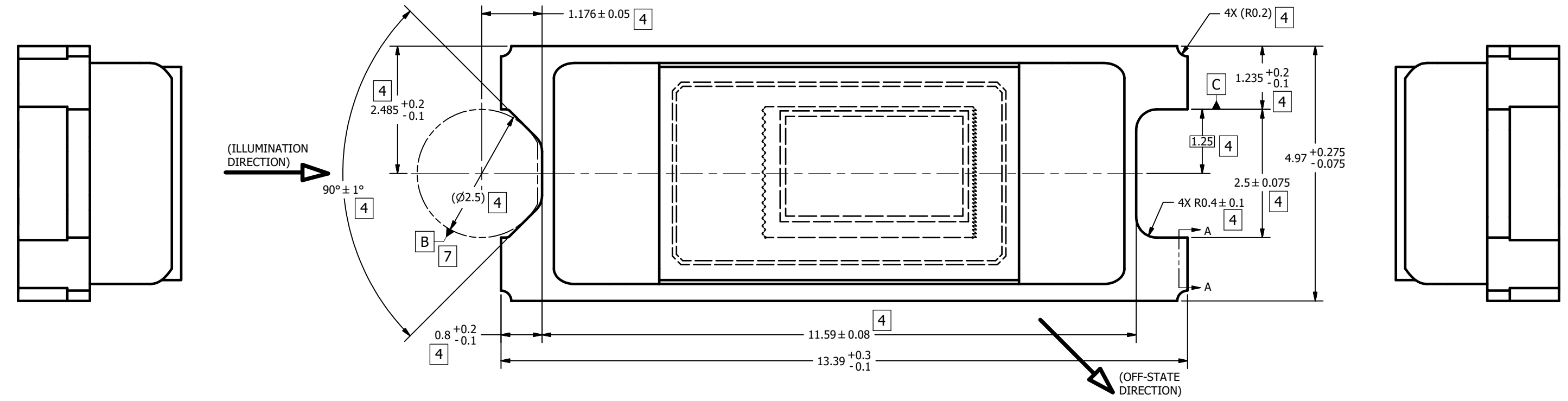

UNLESS OTHERWISE SPECIFIED ● DIMENSIONS ARE IN MILLIMETERS ● TOLERANCES: ANGLES ± 1' 2 PLACE DECIMALS ± 0.25 1 PLACE DECIMALS ± 0.50 ● DIMENSIONAL LIMITS APPLY BEFORE PROCEEDING ● INTERPRET DIMENSIONS IN ACCORDANCE WITH ASME Y14.5M-1994 ● REMOVE ALL BURRS AND SHARP EDGES ● PARENTHETICAL INFORMATION FOR REFERENCE ONLY	DRAWN B. HASKETT ENGINEER B. HASKETT QA/CE C. HART CM F. KHAN G. HERMOSILLO APPROVED J. GRIMMETT	DATE 1/4/2021 1/4/2021 1/8/2021 1/4/2021 1/13/2021 1/11/2021	TEXAS INSTRUMENTS Dallas, Texas TITLE ICD, MECHANICAL, DMD, .16 nHD SERIES 248 (FQT PACKAGE) SIZE D SCALE 25:1	DWG NO. 2517439 SHEET 1 OF 3
	APPLICATION 0314DA NEXT ASSY USED ON	REV A		

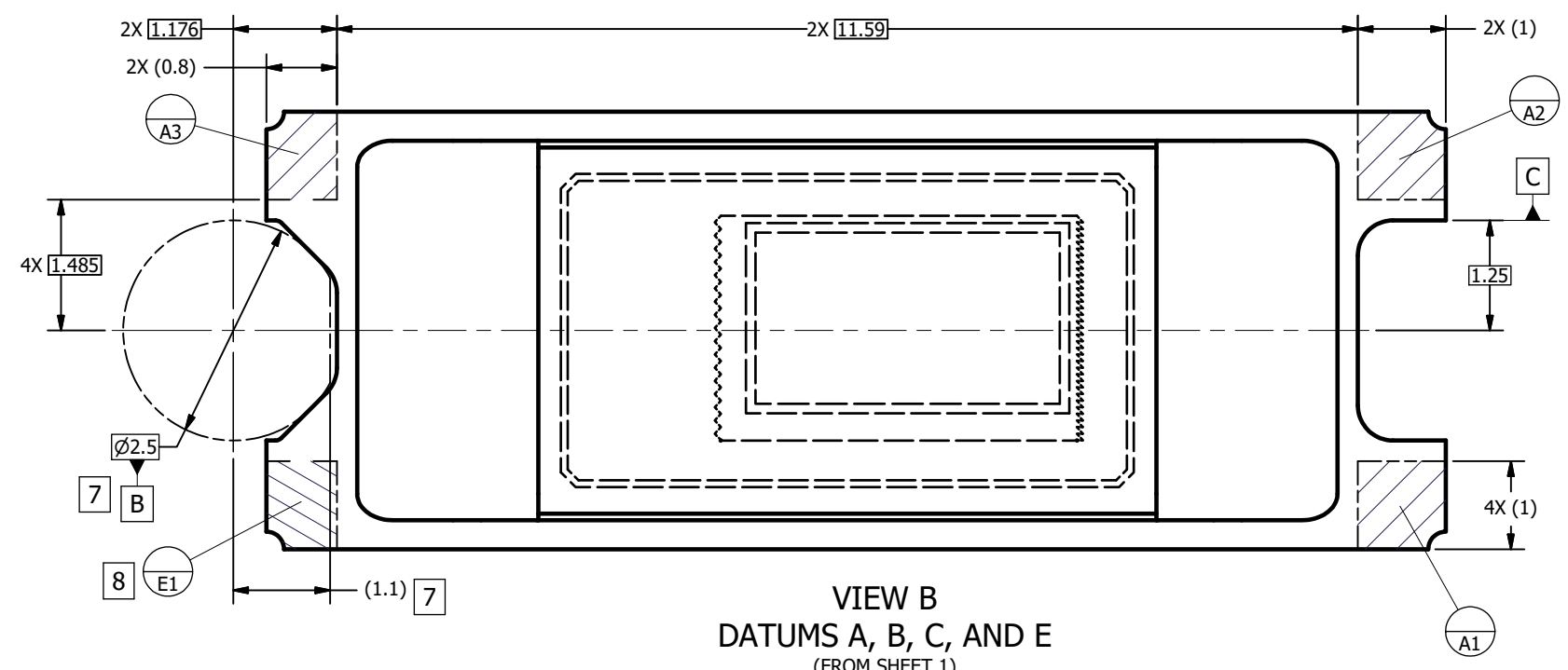

VIEW B
DATUMS A, B, C, AND E
(FROM SHEET 1)

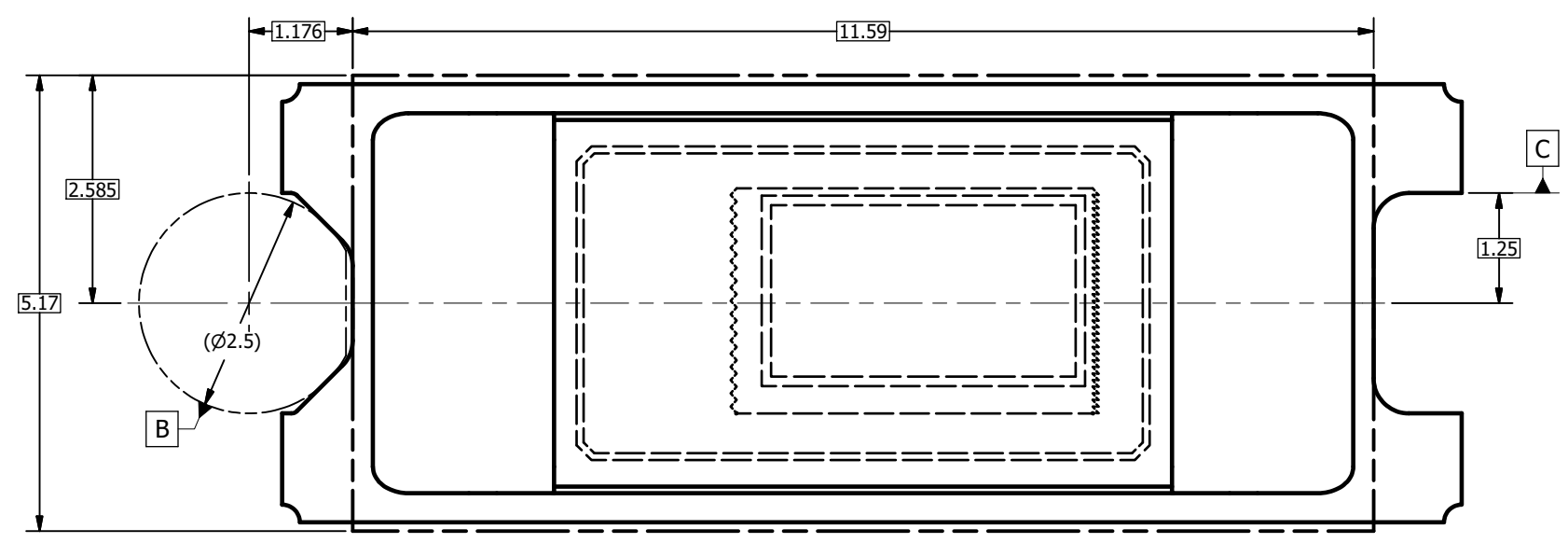

VIEW C
ENCAPSULANT MAXIMUM X/Y DIMENSIONS [5]
(FROM SHEET 1)

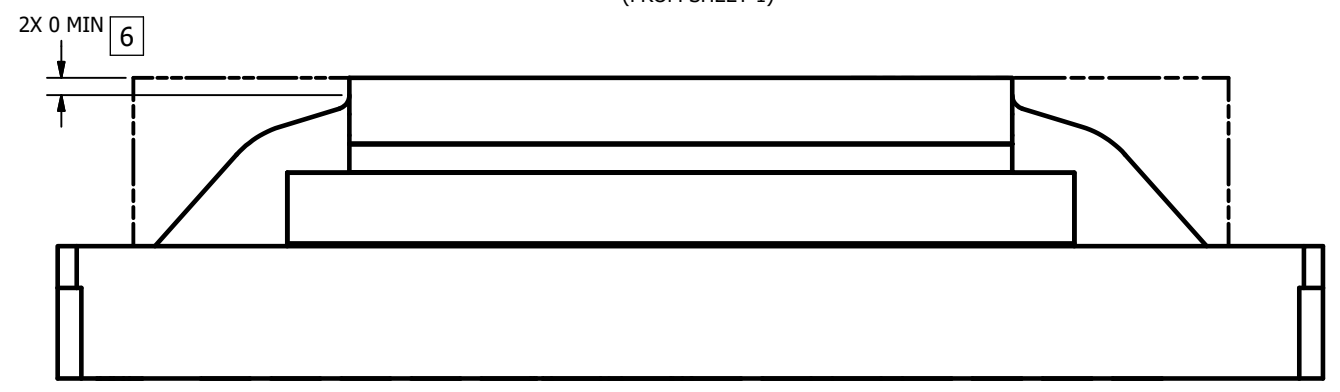

VIEW D
ENCAPSULANT MAXIMUM HEIGHT

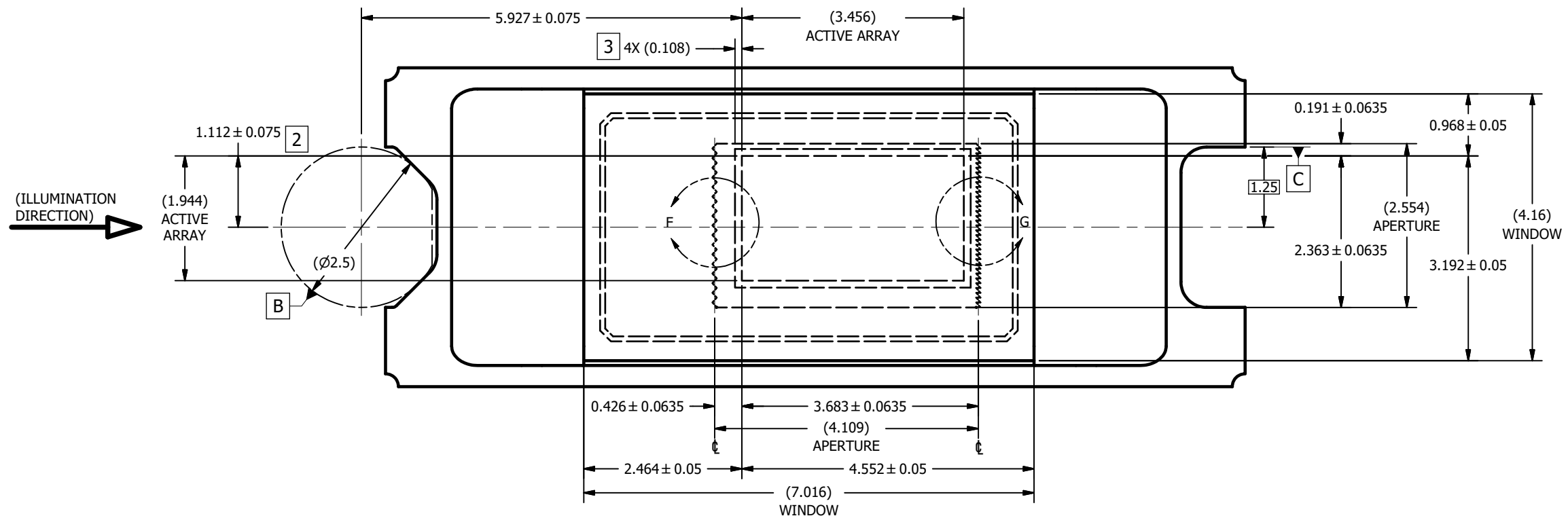

VIEW E
WINDOW AND ACTIVE ARRAY
(FROM SHEET 1)

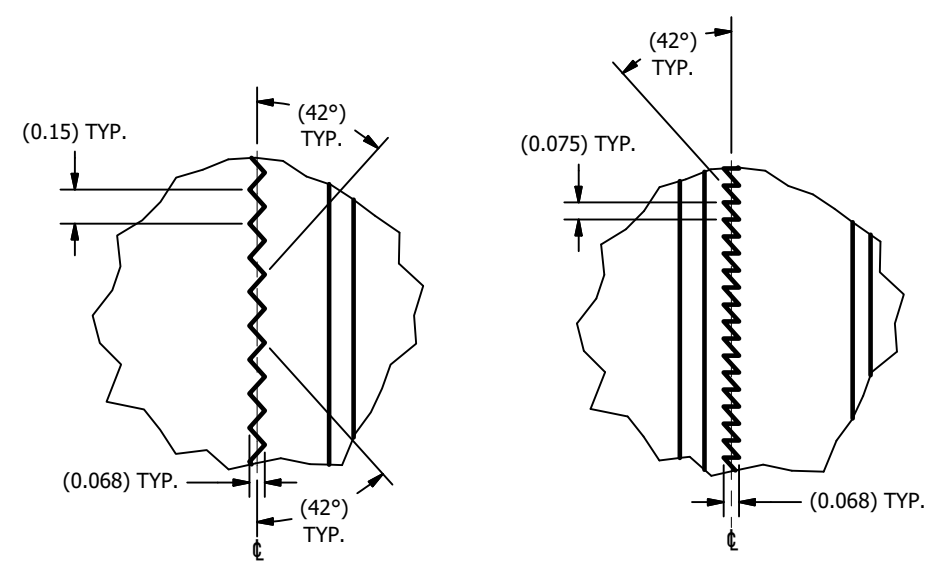

DETAIL F
APERTURE LEFT EDGE
(WINDOW OMITTED FOR CLARITY)
SCALE 60 : 1

DETAIL G
APERTURE RIGHT EDGE
(WINDOW OMITTED FOR CLARITY)
SCALE 60 : 1

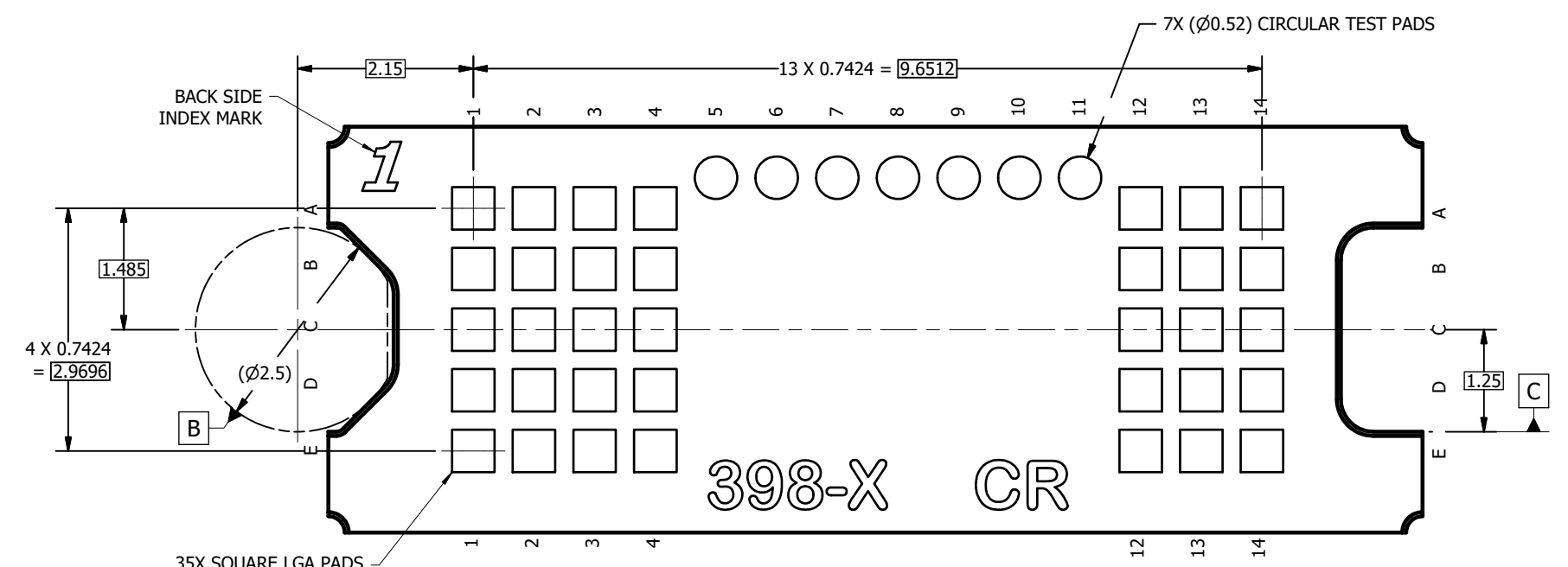

VIEW H-H
BACK SIDE METALLIZATION
(FROM SHEET 1)

IMPORTANT NOTICE AND DISCLAIMER

TI PROVIDES TECHNICAL AND RELIABILITY DATA (INCLUDING DATASHEETS), DESIGN RESOURCES (INCLUDING REFERENCE DESIGNS), APPLICATION OR OTHER DESIGN ADVICE, WEB TOOLS, SAFETY INFORMATION, AND OTHER RESOURCES "AS IS" AND WITH ALL FAULTS, AND DISCLAIMS ALL WARRANTIES, EXPRESS AND IMPLIED, INCLUDING WITHOUT LIMITATION ANY IMPLIED WARRANTIES OF MERCHANTABILITY, FITNESS FOR A PARTICULAR PURPOSE OR NON-INFRINGEMENT OF THIRD PARTY INTELLECTUAL PROPERTY RIGHTS.

These resources are intended for skilled developers designing with TI products. You are solely responsible for (1) selecting the appropriate TI products for your application, (2) designing, validating and testing your application, and (3) ensuring your application meets applicable standards, and any other safety, security, or other requirements. These resources are subject to change without notice. TI grants you permission to use these resources only for development of an application that uses the TI products described in the resource. Other reproduction and display of these resources is prohibited. No license is granted to any other TI intellectual property right or to any third party intellectual property right. TI disclaims responsibility for, and you will fully indemnify TI and its representatives against, any claims, damages, costs, losses, and liabilities arising out of your use of these resources.

TI's products are provided subject to TI's Terms of Sale (<https://www.ti.com/legal/termsofsale.html>) or other applicable terms available either on [ti.com](https://www.ti.com) or provided in conjunction with such TI products. TI's provision of these resources does not expand or otherwise alter TI's applicable warranties or warranty disclaimers for TI products.

Mailing Address: Texas Instruments, Post Office Box 655303, Dallas, Texas 75265
Copyright © 2021, Texas Instruments Incorporated