

# MSP430AFE2x3, MSP430AFE2x2, MSP430AFE2x1 Mixed-Signal Microcontrollers

## 1 Device Overview

### 1.1 Features

- Low Supply Voltage Range: 1.8 V to 3.6 V
- Ultra-Low Power Consumption
  - Active Mode: 220  $\mu$ A at 1 MHz, 2.2 V
  - Standby Mode: 0.5  $\mu$ A
  - Off Mode (RAM Retention): 0.1  $\mu$ A
- Five Power-Saving Modes
- Ultra-Fast Wake-up From Standby Mode in Less Than 1  $\mu$ s
- 16-Bit RISC Architecture, up to 12-MHz System Clock
- Basic Clock Module Configurations
  - Internal Frequencies up to 12 MHz With Two Calibrated Frequencies
  - Internal Very-Low-Power Low-Frequency (LF) Oscillator
  - High-Frequency (HF) Crystal up to 16 MHz Resonator
  - External Digital Clock Source
- Up to Three 24-Bit Sigma-Delta Analog-to-Digital Converters (ADCs) With Differential PGA Inputs
- 16-Bit Timer\_A With Three Capture/Compare Registers
- Serial Communication Interface (USART), Asynchronous UART or Synchronous SPI Selectable by Software
- 16-Bit Hardware Multiplier
- Brownout Detector
- Supply Voltage Supervisor and Monitor With Programmable Level Detection
- Serial Onboard Programming, No External Programming Voltage Needed Programmable Code Protection by Security Fuse
- On-Chip Emulation Module
- [Device Comparison](#) Summarizes the Available Family Members
- For Complete Module Descriptions, See the [MSP430x2xx Family User's Guide](#)

### 1.2 Applications

- Single-Phase Electricity Meters
- Digital Power Monitoring
- Sensor Applications

### 1.3 Description

The TI MSP family of ultra-low-power microcontrollers consists of several devices featuring different sets of peripherals targeted for various applications. The architecture, combined with five low-power modes, is optimized to achieve extended battery life in portable measurement applications. The device features a powerful 16-bit RISC CPU, 16-bit registers, and constant generators that contribute to maximum code efficiency. The digitally controlled oscillator (DCO) allows the device to wake up from low-power modes to active mode in less than 1  $\mu$ s.

The MSP430AFE2x3 devices are ultra-low-power mixed signal microcontrollers integrating three independent 24-bit sigma-delta ADCs, one 16-bit timer, one 16-bit hardware multiplier, USART communication interface, watchdog timer, and 11 I/O pins.

The MSP430AFE2x2 devices are identical to the MSP430AFE2x3, except that there are only two 24-bit sigma-delta ADCs integrated.

The MSP430AFE2x1 devices are identical to the MSP430AFE2x3, except that there is only one 24-bit sigma-delta ADC integrated.

#### Device Information<sup>(1)</sup>

PART NUMBER	PACKAGE	BODY SIZE
MSP430AFE253IPW	TSSOP (24)	7.8 mm x 4.4 mm

(1) For more information, see [Section 8, Mechanical Packaging and Orderable Information](#).



## 1.4 Functional Block Diagram

Figure 1-1 shows the functional block diagram.

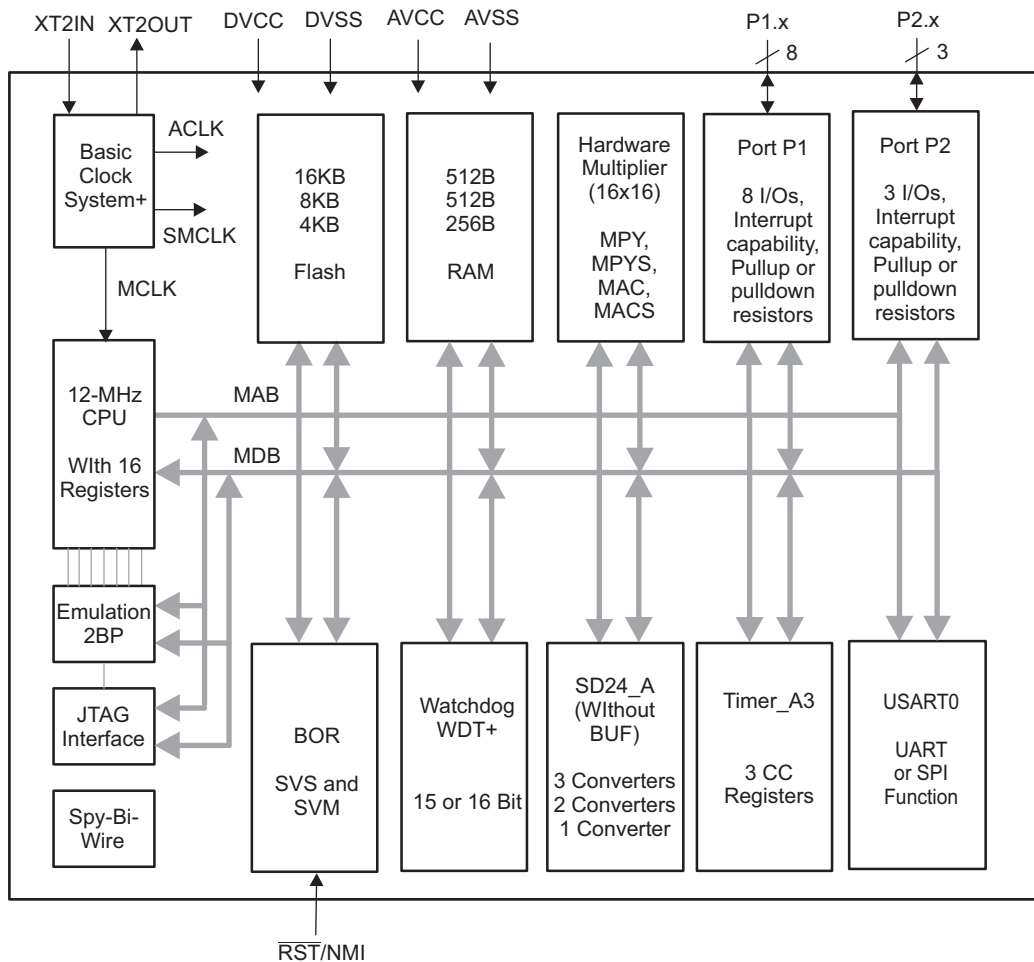

Figure 1-1. Functional Block Diagram

## Table of Contents

<b>1</b>	<b>Device Overview</b>	<b>1</b>	5.26	SD24_A, Input Range	<b>23</b>
1.1	Features	1	5.27	SD24_A, Performance	<b>24</b>
1.2	Applications	1	5.28	SD24_A, Temperature Sensor and Built-In V <sub>CC</sub> Sense	<b>24</b>
1.3	Description	1	5.29	SD24_A, Built-In Voltage Reference	<b>24</b>
1.4	Functional Block Diagram	2	5.30	SD24_A, Reference Output Buffer	<b>25</b>
<b>2</b>	<b>Revision History</b>	<b>4</b>	5.31	SD24_A, External Reference Input	<b>25</b>
<b>3</b>	<b>Device Comparison</b>	<b>5</b>	5.32	USART0	<b>25</b>
3.1	Related Products	5	5.33	Timer_A3	<b>25</b>
<b>4</b>	<b>Terminal Configuration and Functions</b>	<b>6</b>	5.34	Flash Memory	<b>26</b>
4.1	Pin Diagrams	6	5.35	RAM	<b>26</b>
4.2	Signal Descriptions	7	5.36	JTAG and Spy-Bi-Wire Interface	<b>27</b>
<b>5</b>	<b>Specifications</b>	<b>9</b>	5.37	JTAG Fuse	<b>27</b>
5.1	Absolute Maximum Ratings	9	<b>6</b>	<b>Detailed Description</b>	<b>28</b>
5.2	ESD Ratings	9	6.1	CPU	<b>28</b>
5.3	Recommended Operating Conditions	9	6.2	Instruction Set	<b>29</b>
5.4	Thermal Resistance Characteristics for PW-24 Package	10	6.3	Operating Modes	<b>30</b>
5.5	Active Mode Supply Current (Into DVCC and AVCC) Excluding External Current	11	6.4	Interrupt Vector Addresses	<b>31</b>
5.6	Typical Characteristics – Active-Mode Supply Current (Into DVCC and AVCC)	11	6.5	Special Function Registers	<b>32</b>
5.7	Low-Power-Mode Supply Currents (Into V <sub>CC</sub> ) Excluding External Current	12	6.6	Memory Organization	<b>34</b>
5.8	Typical Characteristics – LPM4 Current	12	6.7	Flash Memory	<b>34</b>
5.9	Schmitt-Trigger Inputs (Ports Px and $\overline{\text{RST}}/\text{NMI}$ )	13	6.8	Peripherals	<b>35</b>
5.10	Leakage Current (Ports Px)	13	6.9	Oscillator and System Clock	<b>35</b>
5.11	Outputs (Ports Px)	13	6.10	Brownout, Supply Voltage Supervisor	<b>35</b>
5.12	Output Frequency (Ports Px)	13	6.11	Digital I/O	<b>35</b>
5.13	Typical Characteristics – Outputs	14	6.12	Watchdog Timer (WDT+)	<b>36</b>
5.14	POR, BOR	15	6.13	Timer_A3	<b>36</b>
5.15	Typical Characteristics – POR, BOR	16	6.14	USART0	<b>36</b>
5.16	Supply Voltage Supervisor (SVS), Supply Voltage Monitor (SVM)	17	6.15	Hardware Multiplier	<b>36</b>
5.17	Main DCO Characteristics	19	6.16	SD24_A	<b>37</b>
5.18	DCO Frequency	19	6.17	Peripheral File Map	<b>37</b>
5.19	Calibrated DCO Frequencies – Tolerance	20	6.18	I/O Port Schematics	<b>39</b>
5.20	Wake-up Times From Lower-Power Modes (LPM3, LPM4)	20	<b>7</b>	<b>Device and Documentation Support</b>	<b>48</b>
5.21	Typical Characteristics – DCO Clock Wake-up Time	20	7.1	Getting Started	<b>48</b>
5.22	Internal Very-Low-Power Low-Frequency Oscillator (VLO)	21	7.2	Device Nomenclature	<b>48</b>
5.23	Crystal Oscillator (XT2)	21	7.3	Tools and Software	<b>50</b>
5.24	Typical Characteristics – XT2 Oscillator	22	7.4	Documentation Support	<b>51</b>
5.25	SD24_A, Power Supply	23	7.5	Related Links	<b>52</b>
			7.6	Community Resources	<b>52</b>
			7.7	Trademarks	<b>52</b>
			7.8	Electrostatic Discharge Caution	<b>53</b>
			7.9	Glossary	<b>53</b>
			<b>8</b>	<b>Mechanical, Packaging, and Orderable Information</b>	<b>54</b>

## 2 Revision History

NOTE: Page numbers for previous revisions may differ from page numbers in the current version.

Changes from March 21, 2011 to June 11, 2018	Page
• Format changes throughout document, including addition of section numbering .....	<a href="#">1</a>
• Added <a href="#">Section 1.2, Applications</a> .....	<a href="#">1</a>
• Added <a href="#">Section 1.4, Functional Block Diagram</a> , and moved functional block diagram to it .....	<a href="#">2</a>
• Added <a href="#">Section 3.1, Related Products</a> .....	<a href="#">5</a>
• Added <a href="#">Section 5, Specifications</a> , and moved all electrical specifications to it .....	<a href="#">9</a>
• Added <a href="#">Section 5.2, ESD Ratings</a> .....	<a href="#">9</a>
• Added <a href="#">Section 5.4, Thermal Resistance Characteristics</a> .....	<a href="#">10</a>
• Removed figure <i>Oscillation Allowance vs Crystal Frequency</i> .....	<a href="#">22</a>
• Added <a href="#">Section 7, Device and Documentation Support</a> .....	<a href="#">48</a>
• Added <a href="#">Section 8, Mechanical Packaging and Orderable Information</a> .....	<a href="#">54</a>

### 3 Device Comparison

Table 3-1 summarizes the available family members.

**Table 3-1. Device Comparison<sup>(1)</sup>**

DEVICE	FLASH (KB)	SRAM (Byte)	EEM	SD24_A CONVERTERS	16-BIT MPY	Timer_A <sup>(2)</sup>	USART (UART, SPI)	CLOCKS	I/O	PACKAGE
MSP430AFE253IPW	16	512	1	3	1	3	1	HF, DCO, VLO	11	24-TSSOP
MSP430AFE233IPW	8	512	1	3	1	3	1	HF, DCO, VLO	11	24-TSSOP
MSP430AFE223IPW	4	256	1	3	1	3	1	HF, DCO, VLO	11	24-TSSOP
MSP430AFE252IPW	16	512	1	2	1	3	1	HF, DCO, VLO	11	24-TSSOP
MSP430AFE232IPW	8	512	1	2	1	3	1	HF, DCO, VLO	11	24-TSSOP
MSP430AFE222IPW	4	256	1	2	1	3	1	HF, DCO, VLO	11	24-TSSOP
MSP430AFE251IPW	16	512	1	1	1	3	1	HF, DCO, VLO	11	24-TSSOP
MSP430AFE231IPW	8	512	1	1	1	3	1	HF, DCO, VLO	11	24-TSSOP
MSP430AFE221IPW	4	256	1	1	1	3	1	HF, DCO, VLO	11	24-TSSOP

(1) For the most current package and ordering information, see the *Package Option Addendum* in [Section 8](#), or see the TI website at [www.ti.com](http://www.ti.com).

(2) Each number in the sequence represents an instantiation of Timer\_A with its associated number of capture compare registers and PWM output generators available. For example, a number sequence of 3, 5 would represent two instantiations of Timer\_A, the first instantiation having 3 and the second instantiation having 5 capture compare registers and PWM output generators, respectively.

#### 3.1 Related Products

For information about other devices in this family of products or related products, see the following links.

**Products for MSP430 ultra-low-power sensing and measurement MCUs** One platform. One ecosystem. Endless possibilities.

**Products for MSP430 ultra-low-power MCUs** MCUs for metrology, monitoring, system control, and communications

**Companion Products for MSP430AFE253** Review products that are frequently purchased or used in conjunction with this product.

**Reference Designs for MSP430AFE253** TI reference designs leverage the best in TI technology – from analog and power management to embedded processors. All designs include a schematic, test data, and design files. Search and download designs at [ti.com/tidesigns](http://ti.com/tidesigns).

## 4 Terminal Configuration and Functions

### 4.1 Pin Diagrams

Figure 4-1 shows the pinout of the MSP430AFE2x3 devices in the 24-pin PW (TSSOP) package.

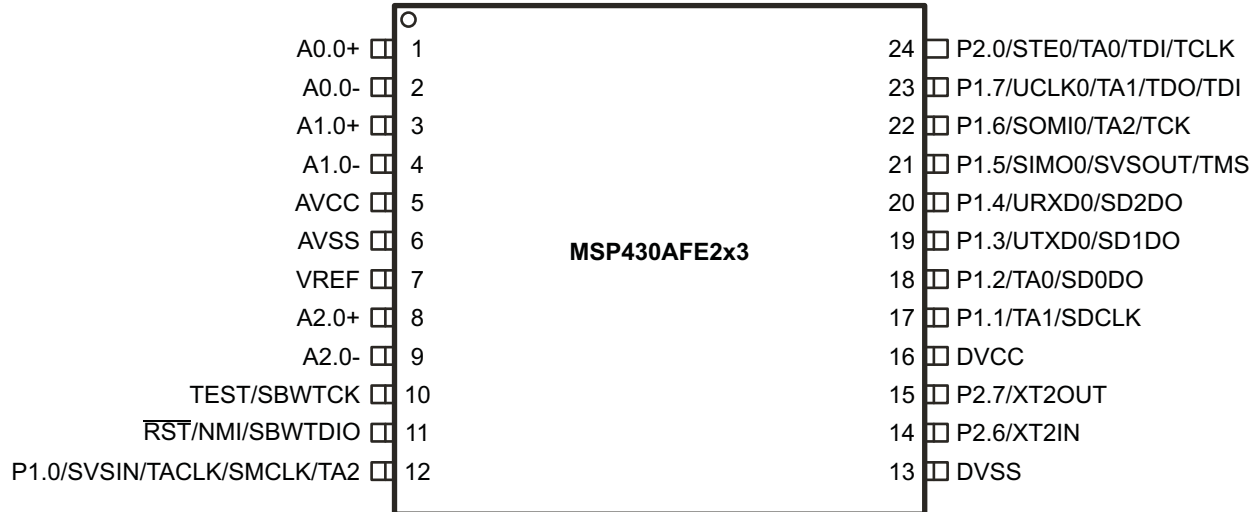
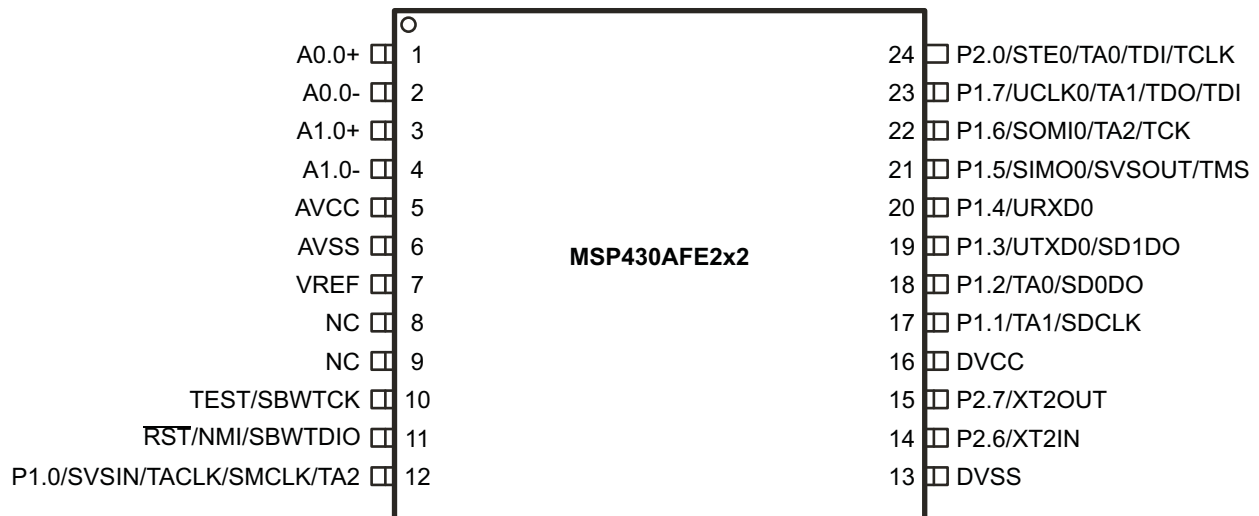

Figure 4-1. 24-Pin PW Package (Top View), MSP430AFE2x3

Figure 4-2 shows the pinout of the MSP430AFE2x2 devices in the 24-pin PW (TSSOP) package.



NOTE: Connect NC pins to analog ground (AVSS)

Figure 4-2. 24-Pin PW Package (Top View), MSP430AFE2x2

Figure 4-3 shows the pinout of the MSP430AFE2x1 devices in the 24-pin PW (TSSOP) package.

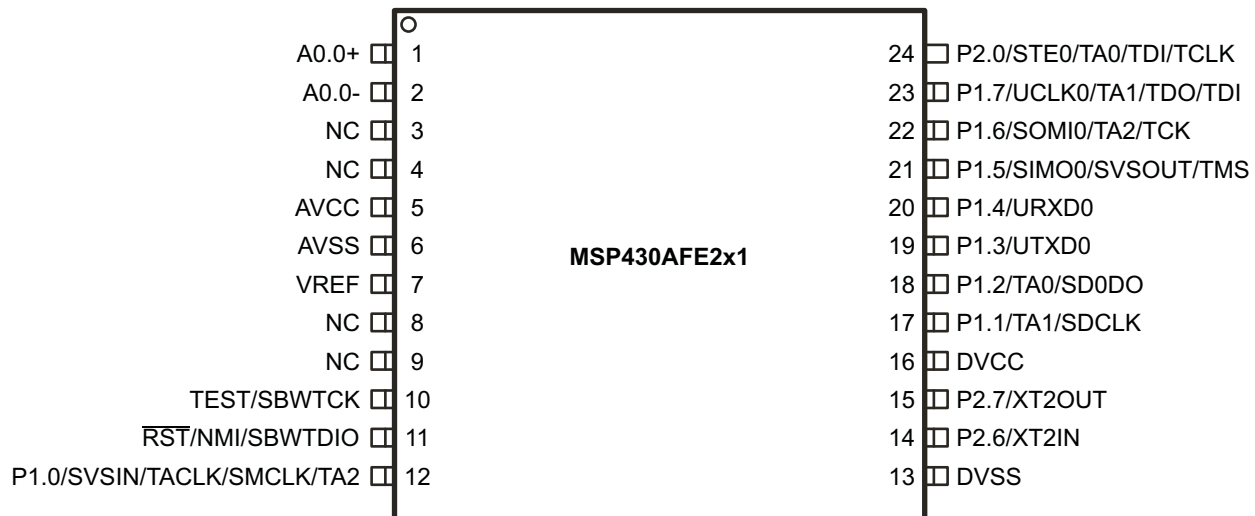

NOTE: Connect NC pins to analog ground (AVSS)

Figure 4-3. 24-Pin PW Package (Top View), MSP430AFE2x1

## 4.2 Signal Descriptions

Table 4-1 describes the signals for all device variants.

Table 4-1. Terminal Functions

TERMINAL		I/O	DESCRIPTION
NAME	NO.		
A0.0+	1	I	SD24_A positive analog input A0.0 <sup>(1)</sup>
A0.0-	2	I	SD24_A negative analog input A0.0 <sup>(1)</sup>
A1.0+	3	I	SD24_A positive analog input A1.0 (not available on MSP430AFE2x1) <sup>(1)</sup>
A1.0-	4	I	SD24_A negative analog input A1.0 (not available on MSP430AFE2x1) <sup>(1)</sup>
AVCC	5		Analog supply voltage, positive terminal. Must not power up prior to DVCC.
AVSS	6		Analog supply voltage, negative terminal
VREF	7	I/O	Input for an external reference voltage output for internal reference voltage (can be used as mid-voltage)
A2.0+	8	I	SD24_A positive analog input A2.0 (not available on MSP430AFE2x2 and MSP430AFE2x1) <sup>(1)</sup>
A2.0-	9	I	SD24_A negative analog input A2.0 (not available on MSP430AFE2x2 and MSP430AFE2x1) <sup>(1)</sup>
TEST/SBWTCK	10	I	Selects test mode for JTAG pins on P1.5 to P1.7 and P2.0. The device protection fuse is connected to TEST. Spy-Bi-Wire test clock input for device programming and test.
RST/NMI/SBWDIO	11	I	Reset or nonmaskable interrupt input Spy-Bi-Wire test data input/output for device programming and test.
P1.0/SVSIN/TACLK/SMCLK/TA2	12	I/O	General-purpose digital I/O pin Analog input to supply voltage supervisor Timer_A3, clock signal TACLK input SMCLK signal output Timer_A3, compare: Out2 Output
DVSS	13		Digital supply voltage, negative terminal
P2.6/XT2IN	14	I/O	Input terminal of crystal oscillator General-purpose digital I/O pin
P2.7/XT2OUT	15	I/O	Output terminal of crystal oscillator General-purpose digital I/O pin

(1) TI recommends shorting unused analog input pairs and connecting them to analog ground.

**Table 4-1. Terminal Functions (continued)**

TERMINAL		I/O	DESCRIPTION
NAME	NO.		
DVCC	16		Digital supply voltage, positive terminal.
P1.1/TA1/SDCLK	17	I/O	General-purpose digital I/O pin Timer_A3, capture: CCI1A and CCI1B inputs, compare: Out1 output SD24_A bit stream clock output
P1.2/TA0/SD0DO	18	I/O	General-purpose digital I/O pin Timer_A3, capture: CCI0A and CCI0B inputs, compare: Out0 output SD24_A bit stream data output for channel 0
P1.3/UTXD0/SD1DO	19	I/O	General-purpose digital I/O pin Transmit data out - USART0 in UART mode SD24_A bit stream data output for channel 1 (not available on MSP430AFE2x1)
P1.4/URXD0/SD2DO	20	I/O	General-purpose digital I/O pin Receive data in - USART0 in UART mode SD24_A bit stream data output for channel 2 (not available on MSP430AFE2x2 and MSP430AFE2x1)
P1.5/SIMO0/SVSOUT/TMS	21	I/O	General-purpose digital I/O Slave in/master out of USART0 in SPI mode SVS: output of SVS comparator JTAG test mode select. TMS is used as an input port for device programming and test.
P1.6/SOMI0/TA2/TCK	22	I/O	General-purpose digital I/O pin Slave out/master in of USART0 in SPI mode Timer_A3, compare: Out2 output JTAG test clock. TCK is the clock input port for device programming and test.
P1.7/UCLK0/TA1/TDO/TDI	23	I/O	General-purpose digital I/O pin External clock input - USART0 in UART or SPI mode, clock output - USART0/SPI mode. Timer_A3, compare: Out1 output JTAG test data output port. TDO/TDI data output or programming data input terminal.
P2.0/STE0/TA0/TDI/TCLK	24	I/O	General-purpose digital I/O pin Slave transmit enable - USART0 in SPI mode. Timer_A3, compare: Out0 output JTAG test data input or test clock input for device programming and test.



## 5 Specifications

### 5.1 Absolute Maximum Ratings<sup>(1)</sup>

over recommended ranges of supply voltage and operating free-air temperature (unless otherwise noted)

		MIN	MAX	UNIT
Voltage applied at $V_{CC}$ to $V_{SS}$		-0.3	4.1	V
Voltage applied to any pin <sup>(2)</sup>		-0.3	$V_{CC} + 0.3$	V
Diode current at any device terminal		-2	2	mA
Storage temperature, $T_{stg}$	Unprogrammed device	-55	150	°C
	Programmed device	-40	85	

- (1) Stresses beyond those listed under *Absolute Maximum Ratings* may cause permanent damage to the device. These are stress ratings only, and functional operation of the device at these or any other conditions beyond those indicated under *Recommended Operating Conditions* is not implied. Exposure to absolute-maximum-rated conditions for extended periods may affect device reliability.
- (2) All voltages referenced to  $V_{SS}$ . The JTAG fuse-blow voltage,  $V_{FB}$ , is allowed to exceed the absolute maximum rating. The voltage is applied to the TEST pin when blowing the JTAG fuse.

### 5.2 ESD Ratings

		VALUE	UNIT
$V_{(ESD)}$ Electrostatic discharge	Human-body model (HBM), per ANSI/ESDA/JEDEC JS-001 <sup>(1)</sup>	±1000	V
	Charged-device model (CDM), per JEDEC specification JESD22-C101 <sup>(2)</sup>	±250	

- (1) JEDEC document JEP155 states that 500-V HBM allows safe manufacturing with a standard ESD control process. Pins listed as ±1000 V may actually have higher performance.
- (2) JEDEC document JEP157 states that 250-V CDM allows safe manufacturing with a standard ESD control process. Pins listed as ±250 V may actually have higher performance.

### 5.3 Recommended Operating Conditions<sup>(1)(2)</sup>

		MIN	NOM	MAX	UNIT
$V_{CC}$ Supply voltage	AVCC = DVCC = $V_{CC}$ <sup>(1)</sup>	During program execution <sup>(3)</sup>	1.8	3.6	V
		During program or erase of flash memory	2.2	3.6	
$V_{SS}$ Supply voltage	AVSS = DVSS = $V_{SS}$		0		V
$T_A$ Operating free-air temperature		-40		85	°C
$f_{SYSTEM}$ Processor frequency (maximum MCLK frequency) <sup>(1)(2)</sup> (see Figure 5-1)	$V_{CC} = 1.8$ V, Duty cycle = 50% ±10%	dc		4.15	MHz
	$V_{CC} = 2.7$ V, Duty cycle = 50% ±10%	dc		9	
	$V_{CC} \geq 3.3$ V, Duty cycle = 50% ±10%	dc		12	

- (1) The MSP430 CPU is clocked directly with MCLK. Both the high and low phases of MCLK must not exceed the pulse duration of the specified maximum frequency.
- (2) Modules might have a different maximum input clock specification. See the specification of the respective module in this data sheet.
- (3) The operating voltage range for SD24\_A is 2.5 V to 3.6 V

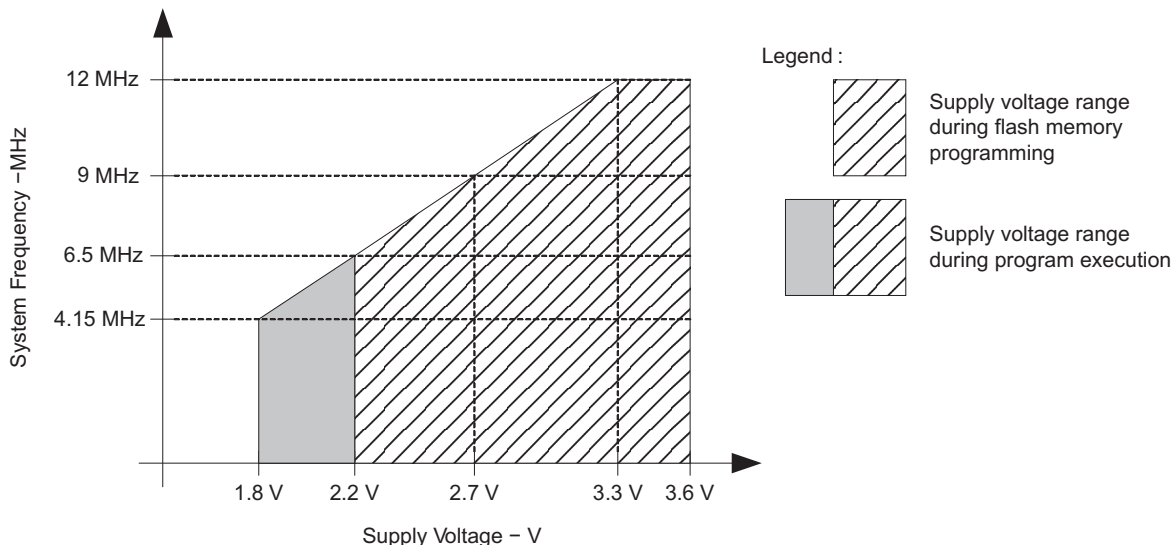

- Minimum processor frequency is defined by system clock. Flash program or erase operations require a minimum  $V_{CC}$  of 2.2 V.
- If high frequency crystal used is above 12 MHz and selected to source CPU clock then MCLK divider should be programmed appropriately to run CPU below 8 MHz.

Figure 5-1. Operating Area

#### 5.4 Thermal Resistance Characteristics for PW-24 Package

THERMAL METRIC <sup>(1)</sup> <sup>(2)</sup>		VALUE <sup>(3)</sup>	UNIT
$R_{\theta JA}$	Junction-to-ambient thermal resistance, still air	76.4	°C/W
$R_{\theta JC(TOP)}$	Junction-to-case (top) thermal resistance	21.1	°C/W
$R_{\theta JC(BOT)}$	Junction-to-case (bottom) thermal resistance	31.7	°C/W
$R_{\theta JB}$	Junction-to-board thermal resistance	31.1	°C/W
$\Psi_{JB}$	Junction-to-board thermal characterization parameter	1.0	°C/W
$\Psi_{JT}$	Junction-to-top thermal characterization parameter	N/A	°C/W

- For more information about traditional and new thermal metrics, see [Semiconductor and IC Package Thermal Metrics](#).
- These values are based on a JEDEC-defined 2S2P system (with the exception of the Theta JC [ $R_{\theta JC}$ ] value, which is based on a JEDEC-defined 1S0P system) and will change based on environment and application. For more information, see these EIA/JEDEC standards:
  - JESD51-2, *Integrated Circuits Thermal Test Method Environmental Conditions - Natural Convection (Still Air)*
  - JESD51-3, *Low Effective Thermal Conductivity Test Board for Leaded Surface Mount Packages*
  - JESD51-7, *High Effective Thermal Conductivity Test Board for Leaded Surface Mount Packages*
  - JESD51-9, *Test Boards for Area Array Surface Mount Package Thermal Measurements*
- N/A = Not applicable

### 5.5 Active Mode Supply Current (Into DVCC and AVCC) Excluding External Current<sup>(1)</sup>

over recommended ranges of supply voltage and operating free-air temperature (unless otherwise noted)

PARAMETER	TEST CONDITIONS	V <sub>CC</sub>	MIN	TYP	MAX	UNIT
I <sub>AM, 1MHz</sub> Active mode (AM) current at 1 MHz	f <sub>DCO</sub> = f <sub>MCLK</sub> = f <sub>SMCLK</sub> = DCO default frequency (approximately 1 MHz), f <sub>ACLK</sub> = f <sub>VLO</sub> = 12 kHz, Program executes in flash, CPUOFF = 0, SCG0 = 0, SCG1 = 0, OSCOFF = 0	2.2 V		220		μA
		3 V		350		
I <sub>AM, 12MHz</sub> Active mode (AM) current at 12 MHz	f <sub>DCO</sub> = f <sub>MCLK</sub> = f <sub>SMCLK</sub> = 12 MHz, f <sub>ACLK</sub> = f <sub>VLO</sub> = 12 kHz, Program executes in flash, CPUOFF = 0, SCG0 = 0, SCG1 = 0, OSCOFF = 0	3.3 V		4.0	4.5	mA

(1) All inputs are tied to 0 V or V<sub>CC</sub>. Outputs do not source or sink any current.

### 5.6 Typical Characteristics – Active-Mode Supply Current (Into DVCC and AVCC)

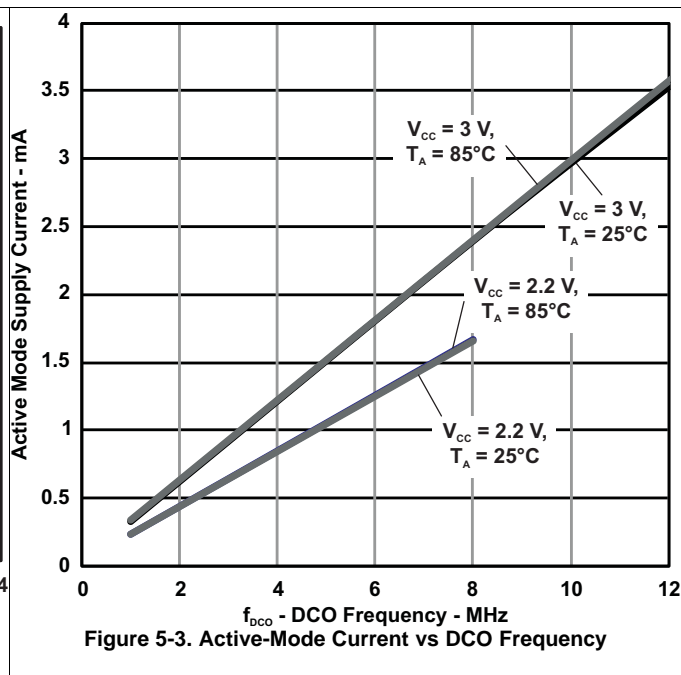
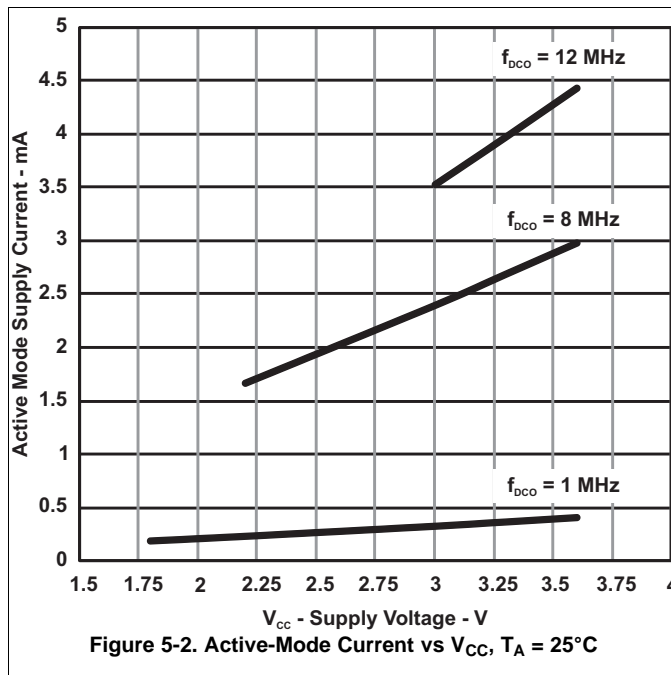

## 5.7 Low-Power-Mode Supply Currents (Into $V_{CC}$ ) Excluding External Current<sup>(1)</sup>

over recommended ranges of supply voltage and operating free-air temperature (unless otherwise noted)

PARAMETER	TEST CONDITIONS	$T_A$	$V_{CC}$	MIN	TYP	MAX	UNIT
$I_{LPM0}$	Low-power mode 0 (LPM0) current <sup>(2)</sup> $f_{MCLK} = 0$ MHz, $f_{SMCLK} = f_{DCO} =$ DCO default frequency (approximately 1 MHz), $f_{ACLK} = f_{VLO} = 12$ kHz, CPUOFF = 1, SCG0 = 0, SCG1 = 0, OSCOFF = 0	25°C	2.2 V		65		$\mu$ A
$I_{LPM2}$	Low-power mode 2 (LPM2) current <sup>(3)</sup> $f_{MCLK} = f_{SMCLK} = 0$ MHz, $f_{DCO} =$ DCO default frequency (approximately 1 MHz), $f_{ACLK} = f_{VLO} = 12$ kHz, CPUOFF = 1, SCG0 = 0, SCG1 = 1, OSCOFF = 0	25°C	2.2 V		22		$\mu$ A
$I_{LPM3,VLO}$	Low-power mode 3 (LPM3) current <sup>(3)</sup> $f_{DCO} = f_{MCLK} = f_{SMCLK} = 0$ MHz, $f_{ACLK} = f_{VLO} = 12$ kHz, CPUOFF = 1, SCG0 = 1, SCG1 = 1, OSCOFF = 0	25°C	2.2 V		0.5	1.0	$\mu$ A
$I_{LPM4}$	Low-power mode 4 (LPM4) current <sup>(4)</sup> $f_{DCO} = f_{MCLK} = f_{SMCLK} = 0$ MHz, $f_{ACLK} = f_{VLO} = 0$ Hz, CPUOFF = 1, SCG0 = 1, SCG1 = 1, OSCOFF = 1	25°C	2.2 V		0.1	0.7	$\mu$ A
		85°C			1.1	2.5	

(1) All inputs are tied to 0 V or  $V_{CC}$ . Outputs do not source or sink any current.

(2) Current for brownout and WDT clocked by SMCLK included.

(3) Current for brownout and WDT clocked by ACLK included.

(4) Current for brownout included.

## 5.8 Typical Characteristics – LPM4 Current

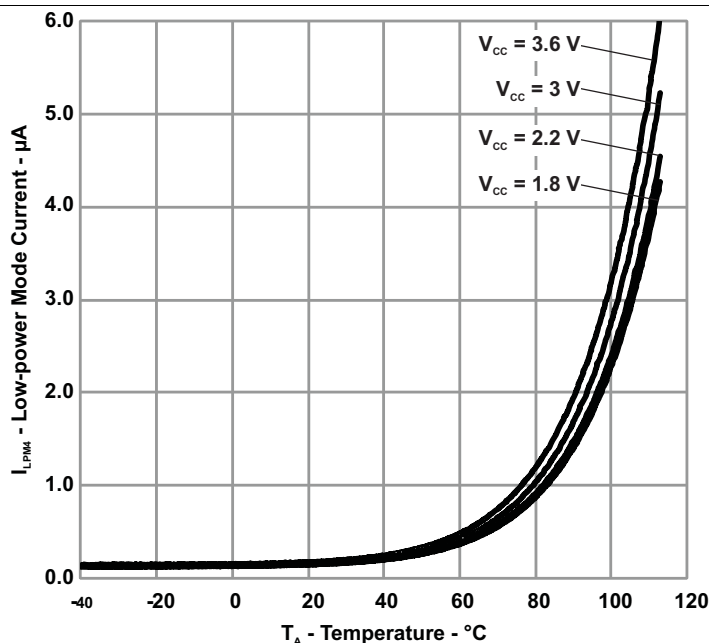

Figure 5-4.  $I_{LPM4}$  -- LPM4 Current vs Temperature

## 5.9 Schmitt-Trigger Inputs (Ports Px and $\overline{\text{RST/NMI}}$ )

over recommended ranges of supply voltage and operating free-air temperature (unless otherwise noted)

PARAMETER		TEST CONDITIONS	V <sub>CC</sub>	MIN	TYP	MAX	UNIT
V <sub>IT+</sub>	Positive-going input threshold voltage			0.45 V <sub>CC</sub>		0.75 V <sub>CC</sub>	V
			3 V	1.35		2.25	
V <sub>IT-</sub>	Negative-going input threshold voltage			0.25 V <sub>CC</sub>		0.55 V <sub>CC</sub>	V
			3 V	0.75		1.65	
V <sub>hys</sub>	Input voltage hysteresis (V <sub>IT+</sub> – V <sub>IT-</sub> )		3 V	0.3		1.0	V
R <sub>Pull</sub>	Pullup or pulldown resistor (not $\overline{\text{RST/NMI}}$ pin)	For pullup: V <sub>IN</sub> = V <sub>SS</sub> , For pulldown: V <sub>IN</sub> = V <sub>CC</sub>	3 V	20	35	50	kΩ
C <sub>I</sub>	Input capacitance	V <sub>IN</sub> = V <sub>SS</sub> or V <sub>CC</sub>			5		pF

## 5.10 Leakage Current (Ports Px)

over recommended ranges of supply voltage and operating free-air temperature (unless otherwise noted)

PARAMETER		TEST CONDITIONS	V <sub>CC</sub>	MIN	MAX	UNIT
I <sub>lkg(Px,y)</sub>	High-impedance leakage current	See <sup>(1)</sup> <sup>(2)</sup>	3 V		±50	nA

(1) The leakage current is measured with V<sub>SS</sub> or V<sub>CC</sub> applied to the corresponding pin, unless otherwise noted.

(2) The leakage of the digital port pins is measured individually. The port pin is selected for input and the pullup or pulldown resistor is disabled.

## 5.11 Outputs (Ports Px)

over recommended ranges of supply voltage and operating free-air temperature (unless otherwise noted)

PARAMETER		TEST CONDITIONS	V <sub>CC</sub>	MIN	TYP	MAX	UNIT
V <sub>OH</sub>	High-level output voltage	I <sub>OH(max)</sub> = –6 mA <sup>(1)</sup>	3 V		V <sub>CC</sub> – 0.2		V
V <sub>OL</sub>	Low-level output voltage	I <sub>OL(max)</sub> = 6 mA <sup>(1)</sup>	3 V		V <sub>SS</sub> + 0.2		V

(1) The maximum total current (I<sub>OH(max)</sub> and I<sub>OL(max)</sub>) for all outputs combined cannot exceed ±48 mA to hold the maximum voltage drop specified.

## 5.12 Output Frequency (Ports Px)

over recommended ranges of supply voltage and operating free-air temperature (unless otherwise noted)

PARAMETER		TEST CONDITIONS	V <sub>CC</sub>	MIN	TYP	MAX	UNIT
f <sub>Px,y</sub>	Port output frequency (with load)	Px,y, C <sub>L</sub> = 20 pF, R <sub>L</sub> = 1 kΩ <sup>(1)</sup> <sup>(2)</sup>	3 V		12		MHz
f <sub>Port_CLK</sub>	Clock output frequency	Px,y, C <sub>L</sub> = 20 pF <sup>(2)</sup>	3 V		16		MHz

(1) A resistive divider with two 0.5-kΩ resistors between V<sub>CC</sub> and V<sub>SS</sub> is used as load. The output is connected to the center tap of the divider.

(2) The output voltage reaches at least 10% and 90% V<sub>CC</sub> at the specified toggle frequency.

### 5.13 Typical Characteristics – Outputs

One output loaded at a time.

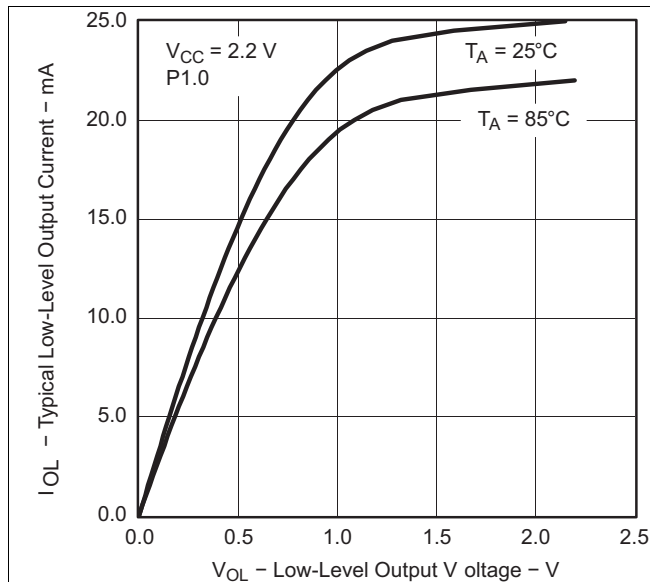

**Figure 5-5. Typical Low-Level Output Current vs Low-Level Output Voltage**

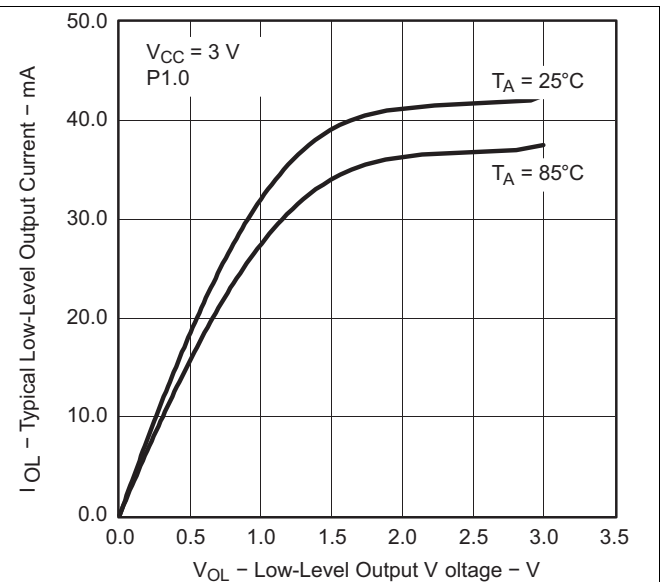

**Figure 5-6. Typical Low-Level Output Current vs Low-Level Output Voltage**

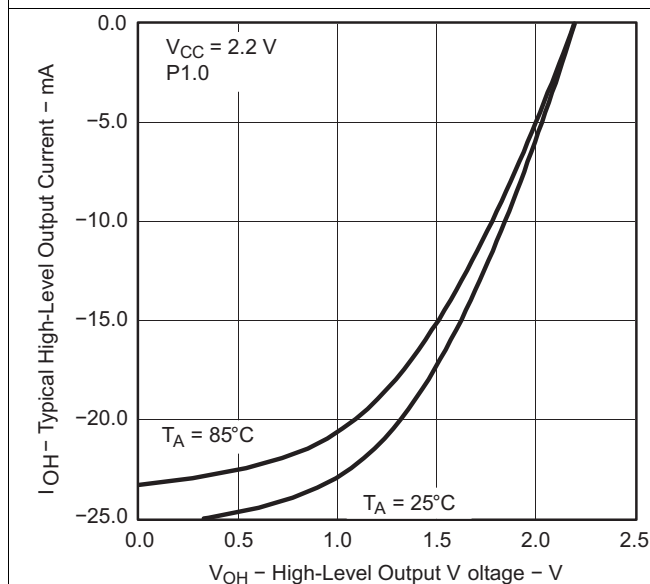

**Figure 5-7. Typical High-Level Output Current vs High-Level Output Voltage**

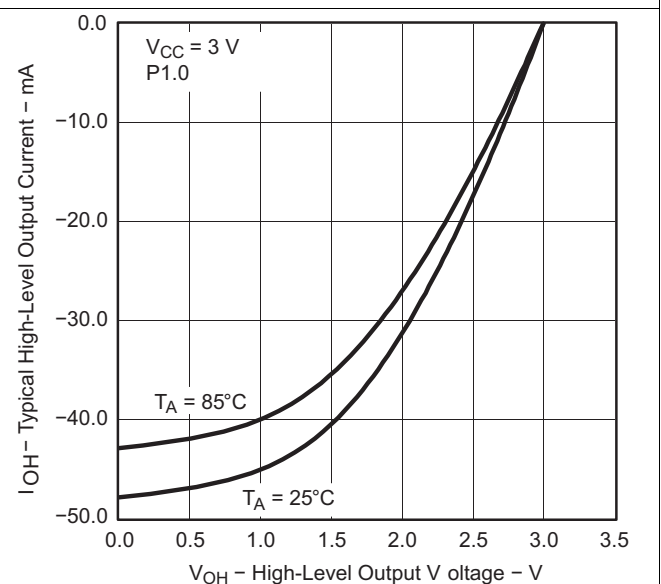

**Figure 5-8. Typical High-Level Output Current vs High-Level Output Voltage**

## 5.14 POR, BOR <sup>(1)(2)</sup>

over recommended ranges of supply voltage and operating free-air temperature (unless otherwise noted)

PARAMETER	TEST CONDITIONS	V <sub>CC</sub>	MIN	TYP	MAX	UNIT
V <sub>CC(start)</sub>	See Figure 5-9			0.7 × V <sub>(B_IT-)</sub>		V
V <sub>(B_IT-)</sub>	See Figure 5-9 through Figure 5-11			1.42		V
V <sub>hys(B_IT-)</sub>	See Figure 5-9			120		mV
t <sub>d(BOR)</sub>	See Figure 5-9			2000		μs
t <sub>(reset)</sub>	Pulse duration needed at $\overline{\text{RST/NMI}}$ pin to accepted reset internally	3 V	2			μs

- (1) The current consumption of the brownout module is already included in the I<sub>CC</sub> current consumption data. The voltage level V<sub>(B\_IT-)</sub> + V<sub>hys(B\_IT-)</sub> is ≤ 1.8 V.
- (2) During power up, the CPU begins code execution following a period of t<sub>d(BOR)</sub> after V<sub>CC</sub> = V<sub>(B\_IT-)</sub> + V<sub>hys(B\_IT-)</sub>. The default DCO settings must not be changed until V<sub>CC</sub> ≥ V<sub>CC(min)</sub>, where V<sub>CC(min)</sub> is the minimum supply voltage for the desired operating frequency.

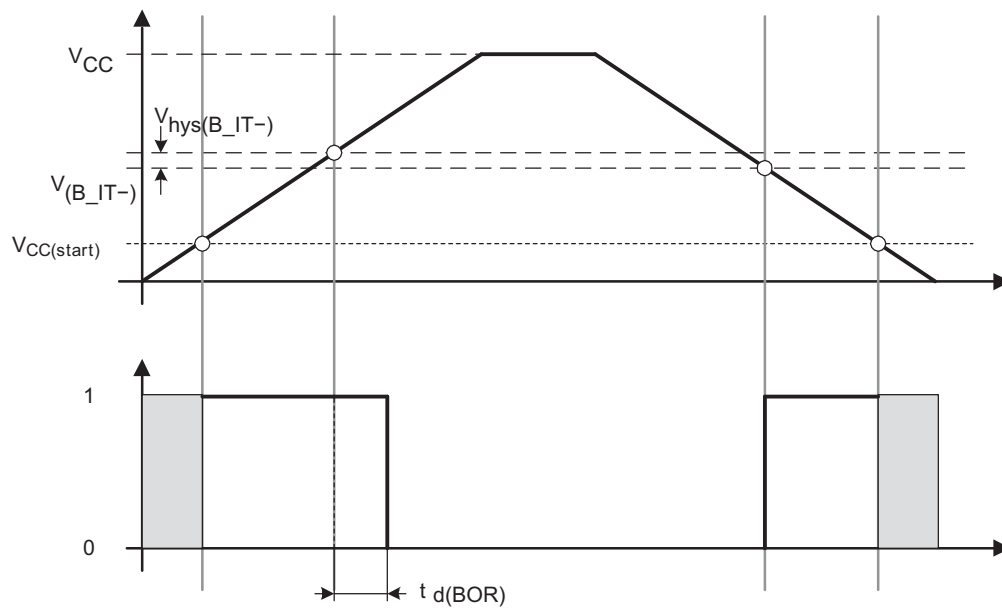

Figure 5-9. POR, BOR vs Supply Voltage

## 5.15 Typical Characteristics – POR, BOR

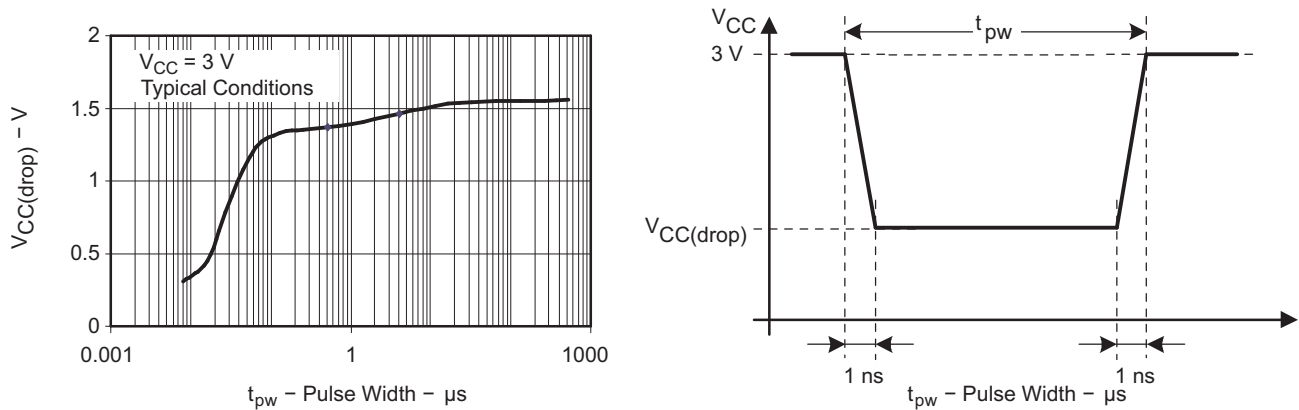

Figure 5-10.  $V_{CC(drop)}$  Level With a Square Voltage Drop to Generate a POR or BOR Signal

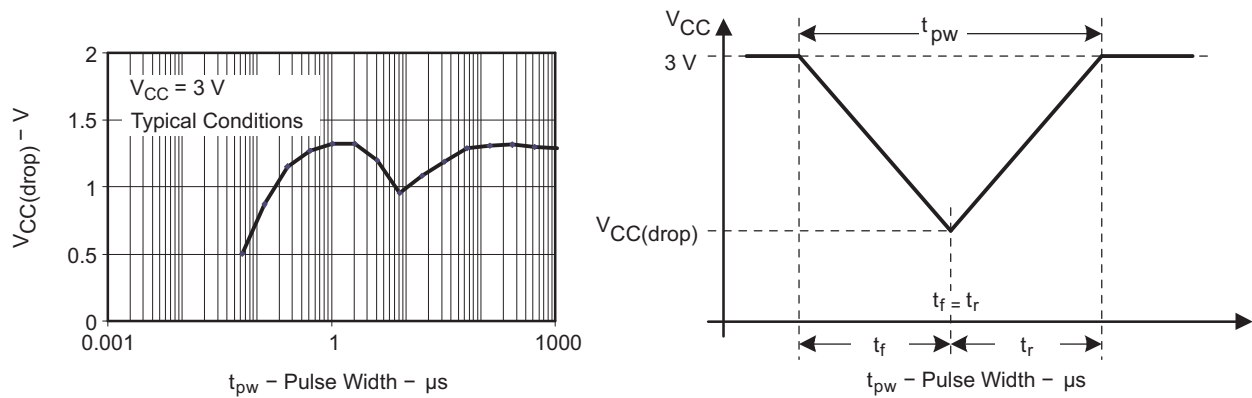

Figure 5-11.  $V_{CC(drop)}$  Level With a Triangular Voltage Drop to Generate a POR or BOR Signal



## 5.16 Supply Voltage Supervisor (SVS), Supply Voltage Monitor (SVM)<sup>(1)</sup>

over recommended ranges of supply voltage and operating free-air temperature (unless otherwise noted)

PARAMETER	TEST CONDITIONS		MIN	TYP	MAX	UNIT		
$t_{\text{SVSR}}$	$dV_{\text{CC}}/dt > 30 \text{ V/ms}$ (see Figure 5-12)		100			$\mu\text{s}$		
	$dV_{\text{CC}}/dt \leq 30 \text{ V/ms}$		2000					
$t_{\text{d(SVSON)}}$	SVS on, switch from VLD = 0 to VLD $\neq$ 0, $V_{\text{CC}} = 3 \text{ V}$		100			$\mu\text{s}$		
$t_{\text{settle}}$	VLD $\neq$ 0 <sup>(2)</sup>		12			$\mu\text{s}$		
$V_{\text{(SVSstart)}}$	VLD $\neq$ 0, $V_{\text{CC}}/dt \leq 3 \text{ V/s}$ (see Figure 5-12)		1.55	1.7	V			
$V_{\text{hys(SVS_IT-)}}$	$V_{\text{CC}}/dt \leq 3 \text{ V/s}$ (see Figure 5-12)	VLD = 1	120			mV		
		VLD = 2 to 14	15					
$V_{\text{hys(SVS_IT-)}}$	$V_{\text{CC}}/dt \leq 3 \text{ V/s}$ (see Figure 5-12), external voltage applied on SVSIN		VLD = 15			10		
	$V_{\text{(SVS_IT-)}}$	$V_{\text{CC}}/dt \leq 3 \text{ V/s}$ (see Figure 5-12)	VLD = 1	1.8	1.9	2.05	V	
VLD = 2			2.1					
VLD = 3			2.2					
VLD = 4			2.3					
VLD = 5			2.24	2.4	2.6			
VLD = 6			2.5					
VLD = 7			2.65					
VLD = 8			2.8					
VLD = 9			2.69	2.9	3.13			
VLD = 10			3.05					
VLD = 11			3.2					
VLD = 12			3.35					
VLD = 13			3.24	3.5	3.76 <sup>(3)</sup>			
VLD = 14			3.7 <sup>(3)</sup>					
$V_{\text{(SVS_IT-)}}$	$V_{\text{CC}}/dt \leq 3 \text{ V/s}$ (see Figure 5-12), external voltage applied on SVSIN		VLD = 15			1.1	1.2	1.3
	$I_{\text{CC(SVS)}}$ <sup>(1)</sup>	VLD $\neq$ 0, $V_{\text{CC}} = 3 \text{ V}$		12			17	$\mu\text{A}$

(1) The current consumption of the SVS module is not included in the  $I_{\text{CC}}$  current consumption data.

(2)  $t_{\text{settle}}$  is the settling time that the comparator operational amplifier needs to have a stable level after VLD is switched from VLD  $\neq$  0 to a different VLD value between 2 and 15. The overdrive is assumed to be greater than 50 mV.

(3) The recommended operating voltage range is limited to 3.6 V.

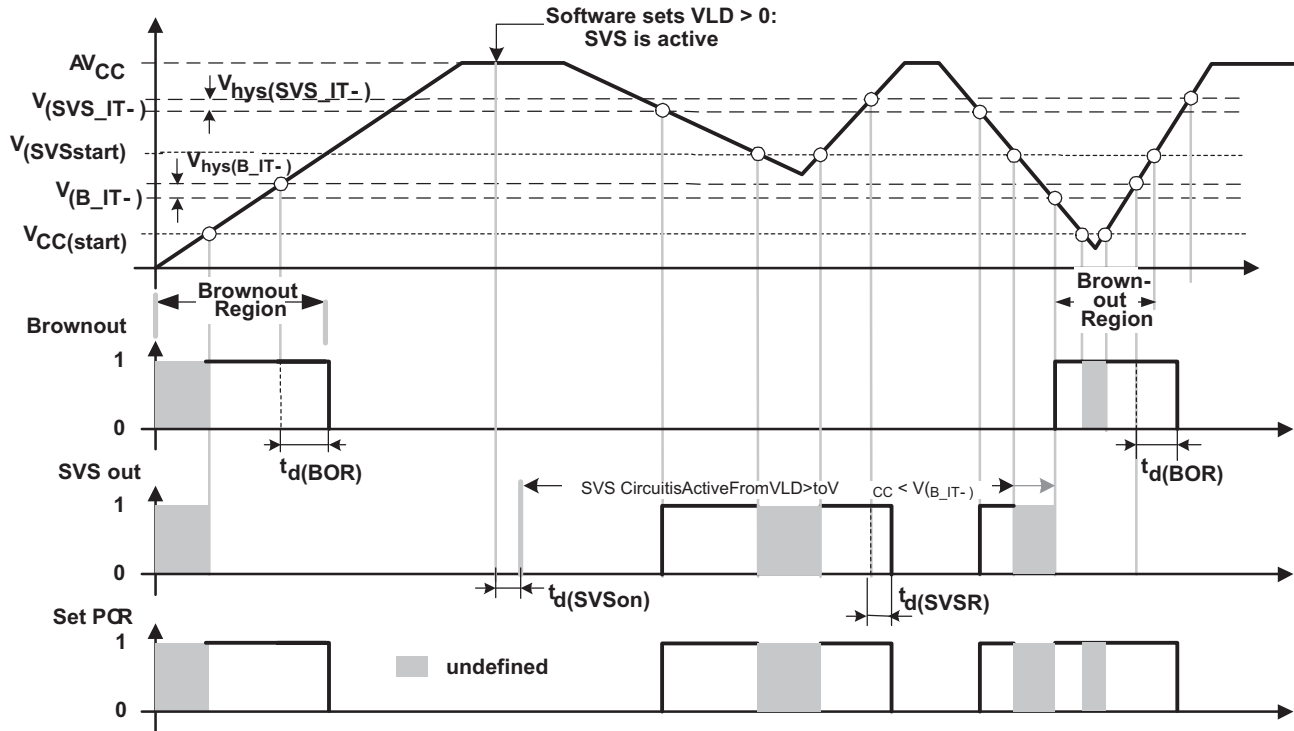

Figure 5-12. SVS Reset (SVSR) vs Supply Voltage

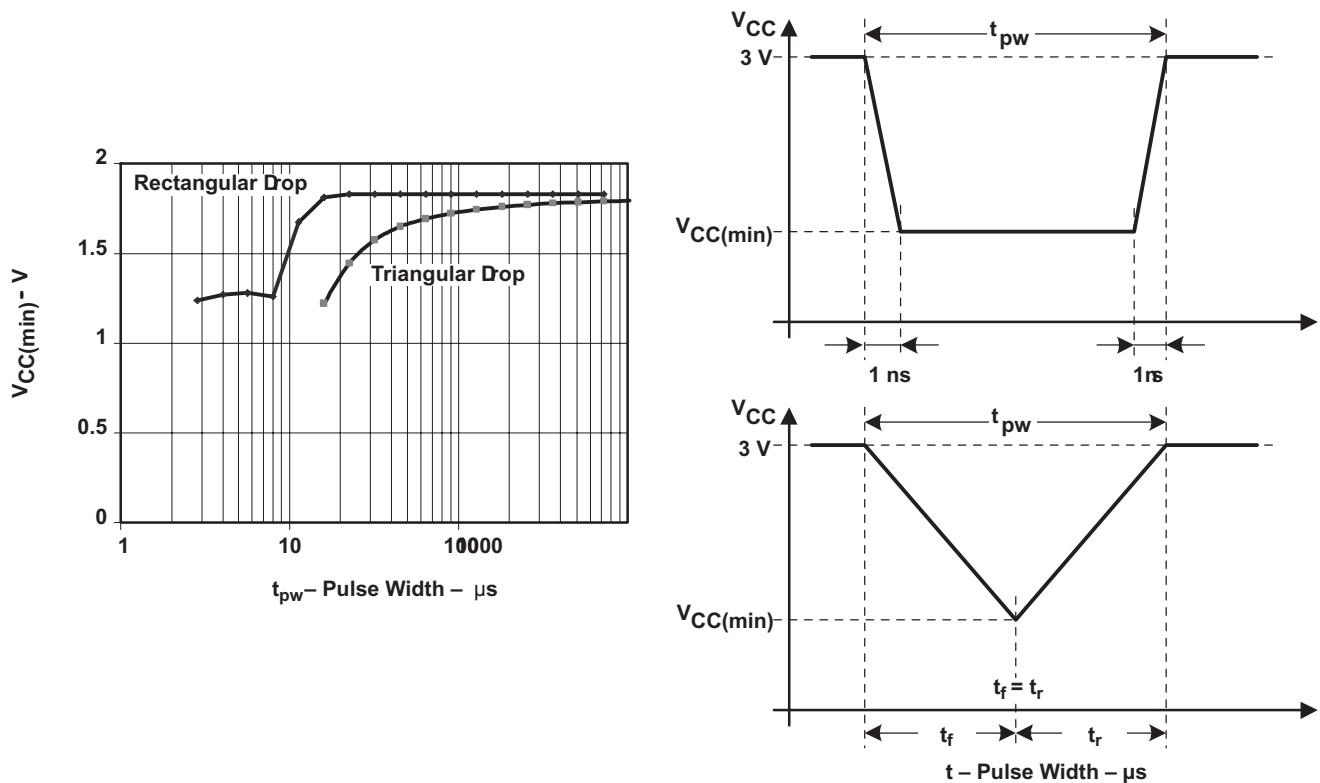

Figure 5-13.  $V_{CC(min)}$  With a Square Voltage Drop and a Triangular Voltage Drop to Generate an SVS Signal

## 5.17 Main DCO Characteristics

- All ranges selected by RSELx overlap with RSELx + 1: RSELx = 0 overlaps RSELx = 1, ... RSELx = 14 overlaps RSELx = 15.
- DCO control bits DCOx have a step size as defined by parameter S<sub>DCO</sub>.
- Modulation control bits MODx select how often f<sub>DCO(RSEL,DCO+1)</sub> is used within the period of 32 DCOCLK cycles. The frequency f<sub>DCO(RSEL,DCO)</sub> is used for the remaining cycles. The frequency is an average equal to:

$$f_{\text{average}} = \frac{32 \times f_{\text{DCO(RSEL,DCO)}} \times f_{\text{DCO(RSEL,DCO+1)}}}{\text{MOD} \times f_{\text{DCO(RSEL,DCO)}} + (32 - \text{MOD}) \times f_{\text{DCO(RSEL,DCO+1)}}}$$

## 5.18 DCO Frequency

over recommended ranges of supply voltage and operating free-air temperature (unless otherwise noted)

PARAMETER		TEST CONDITIONS	V <sub>CC</sub>	MIN	TYP	MAX	UNIT
V <sub>CC</sub>	Supply voltage range	RSELx < 14		1.8		3.6	V
		RSELx = 14		2.2		3.6	
		RSELx = 15		3.0		3.6	
f <sub>DCO(0,0)</sub>	DCO frequency (0, 0)	RSELx = 0, DCOx = 0, MODx = 0	3.3 V	0.06	0.10	0.14	MHz
f <sub>DCO(0,3)</sub>	DCO frequency (0, 3)	RSELx = 0, DCOx = 3, MODx = 0	3.3 V		0.12		MHz
f <sub>DCO(1,3)</sub>	DCO frequency (1, 3)	RSELx = 1, DCOx = 3, MODx = 0	3.3 V		0.15		MHz
f <sub>DCO(2,3)</sub>	DCO frequency (2, 3)	RSELx = 2, DCOx = 3, MODx = 0	3.3 V		0.21		MHz
f <sub>DCO(3,3)</sub>	DCO frequency (3, 3)	RSELx = 3, DCOx = 3, MODx = 0	3.3 V		0.30		MHz
f <sub>DCO(4,3)</sub>	DCO frequency (4, 3)	RSELx = 4, DCOx = 3, MODx = 0	3.3 V		0.41		MHz
f <sub>DCO(5,3)</sub>	DCO frequency (5, 3)	RSELx = 5, DCOx = 3, MODx = 0	3.3 V		0.58		MHz
f <sub>DCO(6,3)</sub>	DCO frequency (6, 3)	RSELx = 6, DCOx = 3, MODx = 0	3.3 V		0.80		MHz
f <sub>DCO(7,3)</sub>	DCO frequency (7, 3)	RSELx = 7, DCOx = 3, MODx = 0	3.3 V		1.15		MHz
f <sub>DCO(8,3)</sub>	DCO frequency (8, 3)	RSELx = 8, DCOx = 3, MODx = 0	3.3 V		1.60		MHz
f <sub>DCO(9,3)</sub>	DCO frequency (9, 3)	RSELx = 9, DCOx = 3, MODx = 0	3.3 V		2.30		MHz
f <sub>DCO(10,3)</sub>	DCO frequency (10, 3)	RSELx = 10, DCOx = 3, MODx = 0	3.3 V		3.40		MHz
f <sub>DCO(11,3)</sub>	DCO frequency (11, 3)	RSELx = 11, DCOx = 3, MODx = 0	3.3 V		4.25		MHz
f <sub>DCO(12,3)</sub>	DCO frequency (12, 3)	RSELx = 12, DCOx = 3, MODx = 0	3.3 V		5.80		M Hz
f <sub>DCO(13,3)</sub>	DCO frequency (13, 3)	RSELx = 13, DCOx = 3, MODx = 0	3.3 V		7.80		MHz
f <sub>DCO(14,3)</sub>	DCO frequency (14, 3)	RSELx = 14, DCOx = 3, MODx = 0	3.3 V	8.6	11.25	13.9	MHz
f <sub>DCO(15,3)</sub>	DCO frequency (15, 3)	RSELx = 15, DCOx = 3, MODx = 0	3.3 V		15.30		MHz
f <sub>DCO(15,7)</sub>	DCO frequency (15, 7)	RSELx = 15, DCOx = 7, MODx = 0	3.3 V		21.00		MHz
S <sub>RSEL</sub>	Frequency step between range RSEL and RSEL+1	S <sub>RSEL</sub> = f <sub>DCO(RSEL+1,DCO)</sub> /f <sub>DCO(RSEL,DCO)</sub>	3.3 V		1.35		ratio
S <sub>DCO</sub>	Frequency step between tap DCO and DCO+1	S <sub>DCO</sub> = f <sub>DCO(RSEL,DCO+1)</sub> /f <sub>DCO(RSEL,DCO)</sub>	3.3 V		1.08		ratio
	Duty cycle	Measured at SMCLK output	3.3 V		50		%

## 5.19 Calibrated DCO Frequencies – Tolerance

over recommended ranges of supply voltage and operating free-air temperature (unless otherwise noted)

PARAMETER	TEST CONDITIONS	T <sub>A</sub>	V <sub>CC</sub>	MIN	TYP	MAX	UNIT
8-MHz tolerance over temperature <sup>(1)</sup>	BCSCTL1 = CALBC1_8MHZ, DCOCTL = CALDCO_8MHZ, calibrated at 30°C and 3.3 V	0°C to 85°C	3.3 V	7.76	8	8.24	MHz
8-MHz tolerance over V <sub>CC</sub>	BCSCTL1 = CALBC1_8MHZ, DCOCTL = CALDCO_8MHZ, calibrated at 30°C and 3.3 V	30°C	2.7 V to 3.6 V	7.76	8	8.24	MHz
8-MHz tolerance overall	BCSCTL1 = CALBC1_8MHZ, DCOCTL = CALDCO_8MHZ, calibrated at 30°C and 3.3 V	–40°C to 85°C	2.7 V to 3.6 V	7.52	8	8.48	MHz
12-MHz tolerance over temperature <sup>(1)</sup>	BCSCTL1 = CALBC1_12MHZ, DCOCTL = CALDCO_12MHZ, calibrated at 30°C and 3.3 V	0°C to 85°C	3.3 V	11.64	12	12.36	MHz
12-MHz tolerance over V <sub>CC</sub>	BCSCTL1 = CALBC1_12MHZ, DCOCTL = CALDCO_12MHZ, calibrated at 30°C and 3.3 V	30°C	3.3 V to 3.6 V	11.64	12	12.36	MHz
12-MHz tolerance overall	BCSCTL1 = CALBC1_12MHZ, DCOCTL = CALDCO_12MHZ, calibrated at 30°C and 3.3 V	–40°C to 85°C	3.3 V to 3.6 V	11.28	12	12.72	MHz

(1) This is the frequency change from the measured frequency at 30°C over temperature.

## 5.20 Wake-up Times From Lower-Power Modes (LPM3, LPM4)

over recommended ranges of supply voltage and operating free-air temperature (unless otherwise noted)

PARAMETER	TEST CONDITIONS	V <sub>CC</sub>	MIN	TYP	MAX	UNIT
t <sub>DCO,LPM3/4</sub>	DCO clock wake-up time from LPM3 or LPM4 <sup>(1)</sup>	f <sub>DCO</sub> = DCO default frequency (approximately 1 MHz)	3 V	1.5		μs
t <sub>CPU,LPM3/4</sub>	CPU wake-up time from LPM3 or LPM4 <sup>(2)</sup>			1 / f <sub>MCLK</sub> + t <sub>DCO,LPM3/4</sub>		μs

(1) The DCO clock wake-up time is measured from the edge of an external wake-up signal (for example, a port interrupt) to the first clock edge observable externally on a clock pin (MCLK or SMCLK).

(2) Parameter applicable only if DCOCLK is used for MCLK.

## 5.21 Typical Characteristics – DCO Clock Wake-up Time

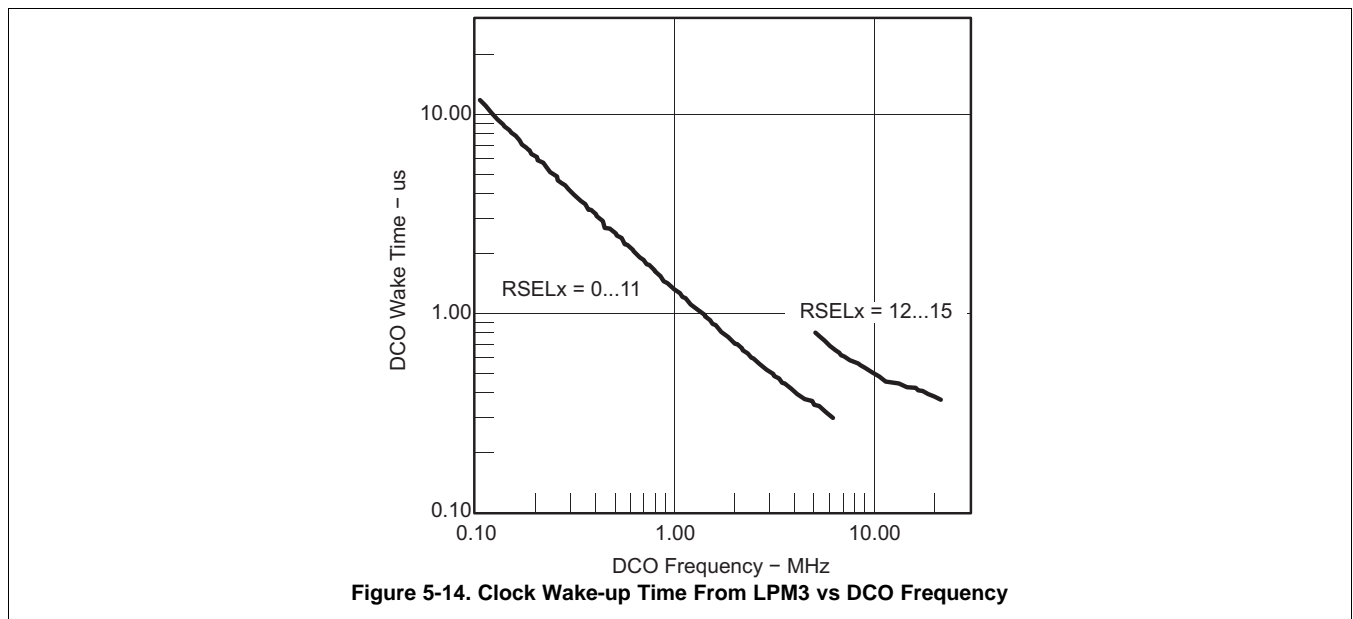

## 5.22 Internal Very-Low-Power Low-Frequency Oscillator (VLO)

over recommended ranges of supply voltage and operating free-air temperature (unless otherwise noted)

PARAMETER		T <sub>A</sub>	V <sub>CC</sub>	MIN	TYP	MAX	UNIT
f <sub>VLO</sub>	VLO frequency	–40°C to 85°C	3 V	4	12	22	kHz
df <sub>VLO</sub> /dT	VLO frequency temperature drift <sup>(1)</sup>	–40°C to 85°C	3 V		0.5		%/°C
df <sub>VLO</sub> /dV <sub>CC</sub>	VLO frequency supply voltage drift <sup>(2)</sup>	25°C	1.8 V to 3.6 V		4		%/V

(1) Calculated using the box method: [MAX(–40°C to 85°C) – MIN(–40°C to 85°C)] / MIN(–40°C to 85°C) / [85°C – (–40°C)]

(2) Calculated using the box method: [MAX(1.8 V to 3.6 V) – MIN(1.8 V to 3.6 V)] / MIN(1.8 V to 3.6 V) / (3.6 V – 1.8 V)

## 5.23 Crystal Oscillator (XT2)<sup>(1)</sup>

over recommended ranges of supply voltage and operating free-air temperature (unless otherwise noted)

PARAMETER		TEST CONDITIONS	V <sub>CC</sub>	MIN	TYP	MAX	UNIT
f <sub>XT2,HF0</sub>	XT2 oscillator crystal frequency, HF mode 0	XT2OFF = 0, XT2Sx = 0	1.8 V to 3.6 V	0.4		1	MHz
f <sub>XT2,HF1</sub>	XT2 oscillator crystal frequency, HF mode 1	XT2OFF = 0, XT2Sx = 1	1.8 V to 3.6 V	1		4	MHz
f <sub>XT2,HF2</sub>	XT2 oscillator crystal frequency, HF mode 2	XT2OFF = 0, XT2Sx = 2	1.8 V to 2.2 V	2		10	MHz
			2.2 V to 3.0 V	2		12	
			3.0 V to 3.6 V	2		16	
f <sub>XT2,HF,logic</sub>	XT2 oscillator logic-level square-wave input frequency, HF mode	XT2OFF = 0, XT2Sx = 3	1.8 V to 2.2 V	0.4		10	MHz
			2.2 V to 3.0 V	0.4		12	
			3.0 V to 3.6 V	0.4		16	
O <sub>AHF</sub>	Oscillation allowance for HF crystals (see Figure 5-15)	XT2OFF = 0, XT2Sx = 0 f <sub>XT2,HF</sub> = 1 MHz, C <sub>L,eff</sub> = 15 pF			2700		Ω
		XT2OFF = 0, XT2Sx = 1 f <sub>XT2,HF</sub> = 4 MHz, C <sub>L,eff</sub> = 15 pF			800		
		XT2OFF = 0, XT2Sx = 2 f <sub>XT2,HF</sub> = 16 MHz, C <sub>L,eff</sub> = 15 pF			300		
C <sub>L,eff</sub>	Integrated effective load capacitance, HF mode <sup>(2)</sup>	XT2OFF = 0 <sup>(3)</sup>			1		pF
Duty cycle	Duty cycle	XT2OFF = 0, Measured at P1.0/SVSIN/TACLK/SMCLK/TA2, f <sub>XT2,HF</sub> = 10 MHz	3 V	40	50	60	%
		XT2OFF = 0, Measured at P1.0/SVSIN/TACLK/SMCLK/TA2, f <sub>XT2,HF</sub> = 16 MHz		40	50	60	
f <sub>Fault,HF</sub>	Oscillator fault frequency <sup>(4)</sup>	XT2OFF = 0, XT2Sx = 3 <sup>(5)</sup>	3 V	30		300	kHz

(1) To improve EMI on the XT2 oscillator, observe the following guidelines:

- Keep the trace between the device and the crystal as short as possible.
- Design a good ground plane around the oscillator pins.
- Prevent crosstalk from other clock or data lines into oscillator pins XT2IN and XT2OUT.
- Avoid running PCB traces underneath or adjacent to the XT2IN and XT2OUT pins.
- Use assembly materials and processes that avoid any parasitic load on the oscillator XT2IN and XT2OUT pins.
- If conformal coating is used, make sure that it does not induce capacitive or resistive leakage between the oscillator pins.

(2) Includes parasitic bond and package capacitance (approximately 2 pF per pin). Because the PCB adds additional capacitance, TI recommends verifying the correct load by measuring the ACLK frequency. For a correct setup, the effective load capacitance should always match the specification of the used crystal.

(3) Requires external capacitors at both terminals. Values are specified by crystal manufacturers.

(4) Frequencies below the MIN specification set the fault flag, frequencies above the MAX specification do not set the fault flag, and frequencies in between might set the flag.

(5) Measured with logic-level input frequency, but also applies to operation with crystals.

## 5.24 Typical Characteristics – XT2 Oscillator

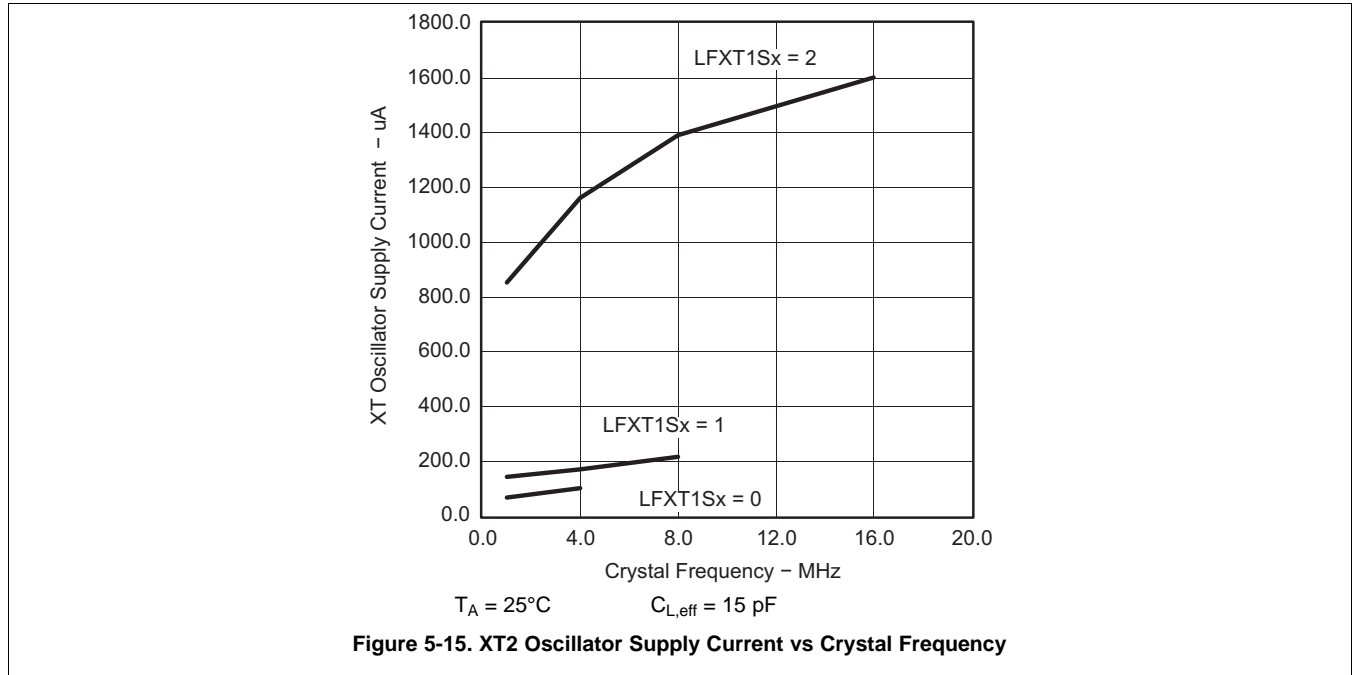

## 5.25 SD24\_A, Power Supply

over recommended ranges of supply voltage and operating free-air temperature (unless otherwise noted)

PARAMETER		TEST CONDITIONS	V <sub>CC</sub>	MIN	TYP	MAX	UNIT	
AV <sub>CC</sub>	Analog supply voltage	AV <sub>CC</sub> = DV <sub>CC</sub> AV <sub>SS</sub> = DV <sub>SS</sub> = 0 V		2.5		3.6	V	
I <sub>SD24</sub>	Analog supply current: 1 active SD24_A channel including internal reference	SD24LP = 0, f <sub>SD24</sub> = 1 MHz, SD24OSR = 256	3 V	GAIN: 1, 2		800	1100	μA
				GAIN: 4, 8, 16		900		
				GAIN: 32		1200		
		SD24LP = 1, f <sub>SD24</sub> = 0.5 MHz, SD24OSR = 256		GAIN: 1		800		
				GAIN: 32		900		
f <sub>SD24</sub>	Analog front-end input clock frequency	SD24LP = 0 (low-power mode disabled)	3 V	0.03	1	1.1	MHz	
		SD24LP = 1 (low-power mode enabled)		0.03	0.5			

## 5.26 SD24\_A, Input Range<sup>(1)</sup>

over recommended ranges of supply voltage and operating free-air temperature (unless otherwise noted)

PARAMETER		TEST CONDITIONS	V <sub>CC</sub>	MIN	TYP	MAX	UNIT
V <sub>ID,FSR</sub>	Differential full-scale input voltage range	Bipolar mode, SD24UNI = 0		$-V_{REF} / 2GAIN$		$+V_{REF} / 2GAIN$	mV
		Unipolar mode, SD24UNI = 1		0		$+V_{REF} / 2GAIN$	
V <sub>ID</sub>	Differential input voltage range for specified performance <sup>(2)</sup>	SD24REFON = 1		SD24GAINx = 1		±500	mV
				SD24GAINx = 2		±250	
				SD24GAINx = 4		±125	
				SD24GAINx = 8		±62	
				SD24GAINx = 16		±31	
				SD24GAINx = 32		±15	
Z <sub>I</sub>	Input impedance (one input pin to AV <sub>SS</sub> )	f <sub>SD24</sub> = 1 MHz	3 V	SD24GAINx = 1		200	kΩ
				SD24GAINx = 32		75	
Z <sub>ID</sub>	Differential input impedance (IN+ to IN-)	f <sub>SD24</sub> = 1 MHz	3 V	SD24GAINx = 1		300	kΩ
				SD24GAINx = 32		100	
V <sub>I</sub>	Absolute input voltage range			AV <sub>SS</sub> – 1		AV <sub>CC</sub>	V
V <sub>IC</sub>	Common-mode input voltage range			AV <sub>SS</sub> – 1		AV <sub>CC</sub>	V

(1) All parameters pertain to each SD24\_A channel.

(2) The full-scale range is defined by V<sub>FSR+</sub> = +(V<sub>REF</sub> / 2) / GAIN and V<sub>FSR-</sub> = -(V<sub>REF</sub> / 2) / GAIN. If V<sub>REF</sub> is sourced externally, the analog input range cannot exceed 80% of V<sub>FSR+</sub> or V<sub>FSR-</sub>; that is, V<sub>ID</sub> = 0.8 × V<sub>FSR-</sub> to 0.8 × V<sub>FSR+</sub>. If V<sub>REF</sub> is sourced internally, the given V<sub>ID</sub> ranges apply.

## 5.27 SD24\_A, Performance

$f_{SD24} = 1$  MHz, SD24OSRx = 256, SD24REFON = 1, over recommended ranges of supply voltage and operating free-air temperature (unless otherwise noted)

PARAMETER		TEST CONDITIONS	V <sub>CC</sub>	MIN	TYP	MAX	UNIT
G	Nominal gain	SD24GAINx = 1	3 V		1		
		SD24GAINx = 2		1.96			
		SD24GAINx = 4		3.86			
		SD24GAINx = 8		7.62			
		SD24GAINx = 16		15.04			
		SD24GAINx = 32		28.35			
E <sub>OS</sub>	Offset error	SD24GAINx = 1	3 V			±0.2	%FSR
		SD24GAINx = 32				±1.5	
ΔEOS/ΔT	Offset error temperature coefficient	SD24GAINx = 1	3 V		±4	±20	ppm FSR/°C
		SD24GAINx = 32			±20	±100	
CMRR	Common-mode rejection ratio	SD24GAINx = 1, Common-mode input signal: V <sub>ID</sub> = 500 mV, f <sub>IN</sub> = 50 Hz or 100 Hz	3 V		>90		dB
		SD24GAINx = 32, Common-mode input signal: V <sub>ID</sub> = 16 mV, f <sub>IN</sub> = 50 Hz or 100 Hz			>75		
AC PSRR	AC power supply rejection ratio	SD24GAINx = 1, V <sub>CC</sub> = 3 V ±100 mV, f <sub>VCC</sub> = 50 Hz	3 V		>80		dB
XT	Crosstalk	SD24GAINx = 1, V <sub>ID</sub> = 500 mV, f <sub>IN</sub> = 50 Hz or 100 Hz	3 V		<-100		dB

## 5.28 SD24\_A, Temperature Sensor and Built-In V<sub>CC</sub> Sense

over recommended ranges of supply voltage and operating free-air temperature (unless otherwise noted)

PARAMETER		TEST CONDITIONS	V <sub>CC</sub>	MIN	TYP	MAX	UNIT
TC <sub>Sensor</sub>	Sensor temperature coefficient			1.18	1.32	1.46	mV/°C
V <sub>Offset,sensor</sub>	Sensor offset voltage			-100		100	mV
V <sub>Sensor</sub>	Sensor output voltage <sup>(1)(2)</sup>	Temperature sensor voltage at T <sub>A</sub> = 85°C	3 V	420	475	515	mV
		Temperature sensor voltage at T <sub>A</sub> = 30°C		350	402	442	
V <sub>CC,Sense</sub>	V <sub>CC</sub> divider at input 5	f <sub>SD24</sub> = 1 MHz, SD24OSRx = 256, SD24REFON = 1			V <sub>CC</sub> /1 1		V
R <sub>Source,VCC</sub>	Source resistance of V <sub>CC</sub> divider at input 5				20		kΩ

(1) The following formula can be used to calculate the temperature sensor output voltage:

$$V_{\text{Sensor,typ}} = TC_{\text{Sensor}} (273 + T [^{\circ}\text{C}]) + V_{\text{Offset,sensor}} [\text{mV}]$$

(2) Results based on characterization and/or production test, not TC<sub>Sensor</sub> or V<sub>Offset,sensor</sub>. Measured with f<sub>SD24</sub> = 1 MHz, SD24OSRx = 256, SD24REFON = 1.

## 5.29 SD24\_A, Built-In Voltage Reference

over recommended ranges of supply voltage and operating free-air temperature (unless otherwise noted)

PARAMETER		TEST CONDITIONS	V <sub>CC</sub>	MIN	TYP	MAX	UNIT
V <sub>REF</sub>	Internal reference voltage	SD24REFON = 1, SD24VMIDON = 0	3 V	1.14	1.2	1.26	V
I <sub>REF</sub>	Reference supply current	SD24REFON = 1, SD24VMIDON = 0	3 V		200	320	μA
TC	Temperature coefficient	SD24REFON = 1, SD24VMIDON = 0 <sup>(1)</sup>	3 V		18	50	ppm/°C
C <sub>REF</sub>	V <sub>REF</sub> load capacitance	SD24REFON = 1, SD24VMIDON = 0 <sup>(2)</sup>			100		nF
I <sub>LOAD</sub>	V <sub>REF(I)</sub> maximum load current	SD24REFON = 1, SD24VMIDON = 0	3 V			±200	nA
t <sub>ON</sub>	Turn-on time	SD24REFON = 0→1, SD24VMIDON = 0, C <sub>REF</sub> = 100 nF	3 V		5		ms
DC PSR	DC power supply rejection ΔV <sub>REF</sub> /ΔV <sub>CC</sub>	SD24REFON = 1, SD24VMIDON = 0, V <sub>CC</sub> = 2.5 V to 3.6 V			100		μV/V

(1) Calculated using the box method: (MAX(-40°C to 85°C) – MIN(-40°C to 85°C)) / MIN(-40°C to 85°C) / (85°C – (-40°C))

(2) There is no capacitance required on V<sub>REF</sub>. However, a capacitance of at least 100 nF is recommended to reduce any reference voltage noise.



### 5.30 SD24\_A, Reference Output Buffer

over recommended ranges of supply voltage and operating free-air temperature (unless otherwise noted)

PARAMETER		TEST CONDITIONS	V <sub>CC</sub>	MIN	TYP	MAX	UNIT
V <sub>REF,BUF</sub>	Reference buffer output voltage	SD24REFON = 1, SD24VMIDON = 1	3 V		1.2		V
I <sub>REF,BUF</sub>	Reference supply + reference output buffer quiescent current	SD24REFON = 1, SD24VMIDON = 1	3 V		430	650	μA
C <sub>REF(O)</sub>	Required load capacitance on VREF	SD24REFON = 1, SD24VMIDON = 1		470			nF
I <sub>LOAD,Max</sub>	Maximum load current on VREF	SD24REFON = 1, SD24VMIDON = 1	3 V			±1	mA
	Maximum voltage variation vs load current	I <sub>LOAD</sub>   = 0 to 1 mA	3 V	-15		+15	mV
t <sub>ON</sub>	Turnon time	SD24REFON = 0→1, SD24VMIDON = 0→1, C <sub>REF</sub> = 470 nF	3 V		100		μs

### 5.31 SD24\_A, External Reference Input

over recommended ranges of supply voltage and operating free-air temperature (unless otherwise noted)

PARAMETER		TEST CONDITIONS	V <sub>CC</sub>	MIN	TYP	MAX	UNIT
V <sub>REF(I)</sub>	Input voltage range	SD24REFON = 0	3 V	1.0	1.25	1.5	V
I <sub>REF(I)</sub>	Input current	SD24REFON = 0	3 V			50	nA

### 5.32 USART0

over recommended ranges of supply voltage and operating free-air temperature (unless otherwise noted)

PARAMETER		TEST CONDITIONS	MIN	TYP	MAX	UNIT
f <sub>USART</sub>	USART clock frequency				8	MHz
t <sub>(τ)</sub>	USART0: deglitch time <sup>(1)</sup>	V <sub>CC</sub> = 3 V, SYNC = 0, UART mode	150	280	500	ns

- (1) The signal applied to the USART0 receive signal/terminal (URXD0) should meet the timing requirements of t<sub>(τ)</sub> to ensure that the URXS flip-flop is set. The URXS flip-flop is set with negative pulses meeting the minimum-timing condition of t<sub>(τ)</sub>. The operating conditions to set the flag must be met independently from this timing constraint. The deglitch circuitry is active only on negative transitions on the URXD0 line.

### 5.33 Timer\_A3

over recommended ranges of supply voltage and operating free-air temperature (unless otherwise noted)

PARAMETER		TEST CONDITIONS	V <sub>CC</sub>	MIN	TYP	MAX	UNIT
f <sub>TA</sub>	Timer_A3 clock frequency	SMCLK, Duty cycle = 50% ±10%			f <sub>SYSTEM</sub>		MHz
t <sub>TA,cap</sub>	Timer_A3, capture timing	TA0, TA1	3 V	20			ns

### 5.34 Flash Memory

over recommended ranges of supply voltage and operating free-air temperature (unless otherwise noted)

PARAMETER		TEST CONDITIONS	V <sub>CC</sub>	MIN	TYP	MAX	UNIT
V <sub>CC(PGM/ERASE)</sub>	Program and erase supply voltage			2.2		3.6	V
f <sub>FTG</sub>	Flash timing generator frequency			257		476	kHz
I <sub>PGM</sub>	Supply current from V <sub>CC</sub> during program		2.2 V, 3.6 V		1	5	mA
I <sub>ERASE</sub>	Supply current from V <sub>CC</sub> during erase		2.2 V, 3.6 V		1	7	mA
t <sub>CPT</sub>	Cumulative program time <sup>(1)</sup>		2.2 V, 3.6 V			10	ms
t <sub>CMErase</sub>	Cumulative mass erase time		2.2 V, 3.6 V	20			ms
	Program and erase endurance			10 <sup>4</sup>	10 <sup>5</sup>		cycles
t <sub>Retention</sub>	Data retention duration	T <sub>J</sub> = 25°C		100			years
t <sub>Word</sub>	Word or byte program time	See <sup>(2)</sup>			30		t <sub>FTG</sub>
t <sub>Block, 0</sub>	Block program time for first byte or word	See <sup>(2)</sup>			25		t <sub>FTG</sub>
t <sub>Block, 1-63</sub>	Block program time for each additional byte or word	See <sup>(2)</sup>			18		t <sub>FTG</sub>
t <sub>Block, End</sub>	Block program end-sequence wait time	See <sup>(2)</sup>			6		t <sub>FTG</sub>
t <sub>Mass Erase</sub>	Mass erase time	See <sup>(2)</sup>			10593		t <sub>FTG</sub>
t <sub>Seg Erase</sub>	Segment erase time	See <sup>(2)</sup>			4819		t <sub>FTG</sub>

- (1) The cumulative program time must not be exceeded when writing to a 64-byte flash block. This parameter applies to all programming methods: individual word/byte write and block write modes.  
(2) These values are hardwired into the state machine of the flash controller (t<sub>FTG</sub> = 1 / f<sub>FTG</sub>).

### 5.35 RAM

over recommended ranges of supply voltage and operating free-air temperature (unless otherwise noted)

PARAMETER		TEST CONDITIONS	MIN	MAX	UNIT
V <sub>(RAMh)</sub>	RAM retention supply voltage <sup>(1)</sup>	CPU halted	1.6		V

- (1) This parameter defines the minimum supply voltage V<sub>CC</sub> when the data in RAM remains unchanged. No program execution should happen during this supply voltage condition.

### 5.36 JTAG and Spy-Bi-Wire Interface

over recommended ranges of supply voltage and operating free-air temperature (unless otherwise noted)

PARAMETER		V <sub>CC</sub>	MIN	TYP	MAX	UNIT
f <sub>SBW</sub>	Spy-Bi-Wire input frequency	3 V	0		20	MHz
t <sub>SBW,Low</sub>	Spy-Bi-Wire low clock pulse duration	3 V	0.025		15	μs
t <sub>SBW,En</sub>	Spy-Bi-Wire enable time (TEST high to acceptance of first clock edge <sup>(1)</sup> )	3 V			1	μs
t <sub>SBW,Ret</sub>	Spy-Bi-Wire return to normal operation time	3 V	15		100	μs
f <sub>TCK</sub>	TCK input frequency <sup>(2)</sup>	3 V	0		10	MHz
R <sub>Internal</sub>	Internal pulldown resistance on TEST	3 V	25	60	90	kΩ

- (1) Tools accessing the Spy-Bi-Wire interface must wait for the maximum t<sub>SBW,En</sub> time after pulling the TEST/SBWCLK pin high before applying the first SBWCLK clock edge.
- (2) f<sub>TCK</sub> may be restricted to meet the timing requirements of the module selected.

### 5.37 JTAG Fuse<sup>(1)</sup>

over recommended ranges of supply voltage and operating free-air temperature (unless otherwise noted)

PARAMETER		TEST CONDITIONS	MIN	MAX	UNIT
V <sub>CC(FB)</sub>	Supply voltage during fuse-blow condition	T <sub>A</sub> = 25°C	2.5		V
V <sub>FB</sub>	Voltage level on TEST for fuse blow		6	7	V
I <sub>FB</sub>	Supply current into TEST during fuse blow			100	mA
t <sub>FB</sub>	Time to blow fuse			1	ms

- (1) After the fuse is blown, no further access to the JTAG Test, Spy-Bi-Wire, or emulation features is possible, and JTAG is switched to bypass mode.

## 6 Detailed Description

### 6.1 CPU

The MSP430 CPU has a 16-bit RISC architecture that is highly transparent to the application. All operations, other than program-flow instructions, are performed as register operations in conjunction with seven addressing modes for source operand and four addressing modes for destination operand.

The CPU is integrated with 16 registers that provide reduced instruction execution time. The register-to-register operation execution time is one cycle of the CPU clock. Four of the registers, R0 to R3, are dedicated as program counter, stack pointer, status register, and constant generator respectively. The remaining registers are general-purpose registers (see [Figure 6-1](#)).

Peripherals are connected to the CPU using data, address, and control buses and can be handled with all instructions.

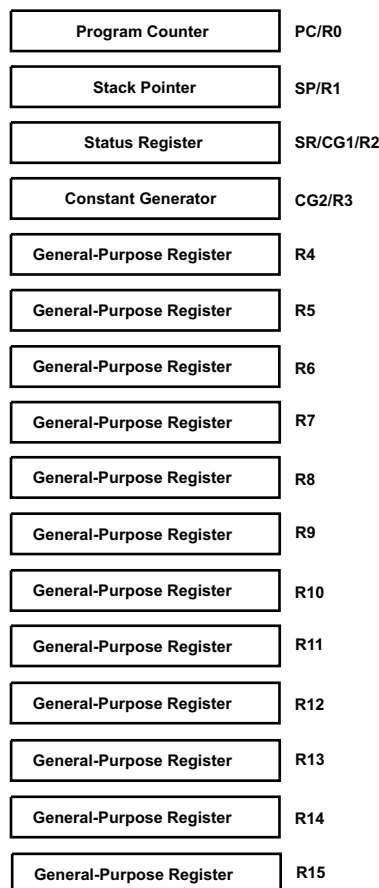

Figure 6-1. CPU Registers

## 6.2 Instruction Set

The instruction set consists of 51 instructions with three formats and seven address modes. Each instruction can operate on word and byte data. [Table 6-1](#) lists examples of the three types of instruction formats. [Table 6-2](#) lists the address modes.

**Table 6-1. Instruction Word Formats**

INSTRUCTION FORMAT	EXAMPLE	OPERATION
Dual operands, source-destination	ADD R4,R5	R4 + R5 → R5
Single operands, destination only	CALL R8	PC → (TOS), R8 → PC
Relative jump, unconditional or conditional	JNE	Jump-on-equal bit = 0

**Table 6-2. Address Mode Descriptions**

ADDRESS MODE	S <sup>(1)</sup>	D <sup>(2)</sup>	SYNTAX	EXAMPLE	OPERATION
Register	✓	✓	MOV Rs,Rd	MOV R10,R11	R10 → R11
Indexed	✓	✓	MOV X(Rn),Y(Rm)	MOV 2(R5),6(R6)	M(2+R5) → M(6+R6)
Symbolic (PC relative)	✓	✓	MOV EDE,TONI		M(EDE) → M(TONI)
Absolute	✓	✓	MOV &MEM,&TCDAT		M(MEM) → M(TCDAT)
Indirect	✓		MOV @Rn,Y(Rm)	MOV @R10,Tab(R6)	M(R10) → M(Tab+R6)
Indirect autoincrement	✓		MOV @Rn+,Rm	MOV @R10+,R11	M(R10) → R11 R10 + 2 → R10
Immediate	✓		MOV #X,TONI	MOV #45,TONI	#45 → M(TONI)

(1) S = source

(2) D = destination

## 6.3 Operating Modes

These microcontrollers have one active mode and five software-selectable low-power modes of operation. An interrupt event can wake up the device from any of the five low-power modes, service the request, and restore back to the low-power mode on return from the interrupt program.

Software can configure the following operating modes:

- Active mode ( AM)
  - All clocks are active.
- Low-power mode 0 (LPM0)
  - CPU is disabled.
  - ACLK and SMCLK remain active. MCLK is disabled.
- Low-power mode 1 (LPM1)
  - CPU is disabled ACLK and SMCLK remain active. MCLK is disabled.
  - DC generator of the DCO is disabled if DCO not used in active mode.
- Low-power mode 2 (LPM2)
  - CPU is disabled.
  - MCLK and SMCLK are disabled.
  - DC generator of the DCO remains enabled.
  - ACLK remains active.
- Low-power mode 3 (LPM3)
  - CPU is disabled.
  - MCLK and SMCLK are disabled.
  - DC generator of the DCO is disabled.
  - ACLK remains active.
- Low-power mode 4 (LPM4)
  - CPU is disabled.
  - ACLK is disabled.
  - MCLK and SMCLK are disabled.
  - DC generator of the DCO is disabled.
  - Crystal oscillator is stopped.

## 6.4 Interrupt Vector Addresses

The interrupt vectors and the power-up starting address are in the address range of 0FFFFh to 0FFE0h (see [Table 6-3](#)). The vector contains the 16-bit address of the appropriate interrupt handler instruction sequence.

If the reset vector (at address 0FFFEh) contains 0FFFFh (for example, if flash is not programmed), the CPU goes into LPM4 immediately after power up.

**Table 6-3. Interrupt Vector Addresses**

INTERRUPT SOURCE	INTERRUPT FLAG	SYSTEM INTERRUPT	WORD ADDRESS	PRIORITY
Power up External reset Watchdog Flash key violation PC out-of-range <sup>(1)</sup>	PORIFG RSTIFG WDTIFG KEYV <sup>(2)</sup>	Reset	0FFFEh	15, highest
NMI Oscillator fault Flash memory access violation	NMIIFG OFIFG ACCVIFG <sup>(2) (3)</sup>	(Non)maskable, (Non)maskable, (Non)maskable	0FFFCCh	14
			0FFFAh	13
SD24_A	SD24CCTLx SD24OVIFG, SD24CCTLx SD24IFG <sup>(2) (4)</sup>	Maskable	0FFF8h	12
			0FFF6h	11
Watchdog Timer	WDTIFG	Maskable	0FFF4h	10
USART0 Receive	URXIFG0	Maskable	0FFF2h	9
USART0 Transmit	UTXIFG0	Maskable	0FFF0h	8
			0FFEEh	7
Timer_A3	TA0CCR0 CCIFG <sup>(4)</sup>	Maskable	0FFECh	6
Timer_A3	TA0CCR1 CCIFG, TA0CCR2 CCIFG, TA0CTL TAIFG <sup>(2) (4)</sup>	Maskable	0FFEAh	5
I/O Port P1 (eight flags)	P1IFG.0 to P1IFG.7 <sup>(2) (4)</sup>	Maskable	0FFE8h	4
			0FFE6h	3
			0FFE4h	2
I/O Port P2 (three flags)	P2IFG.0 to P2IFG.2 <sup>(2) (4)</sup>	Maskable	0FFE2h	1
			0FFE0h	0, lowest

(1) A reset is generated if the CPU tries to fetch instructions from within the module register memory address range (0h to 01FFh) or from within unused address range.

(2) Multiple source flags

(3) (Non)maskable: the individual interrupt-enable bit can disable an interrupt event, but the general interrupt enable cannot.

(4) Interrupt flags are in the module.

## 6.5 Special Function Registers

Most interrupt and module enable bits are collected into the lowest address space. Special function register bits not allocated to a functional purpose are not physically present in the device. Simple software access is provided with this arrangement.

### Legend

- rw Bit can be read and written.
- rw-0, rw-1 Bit can be read and written. It is reset or set by PUC.
- rw-(0), rw-(1) Bit can be read and written. It is reset or set by POR.
- SFR bit is not present in device.

**Figure 6-2. Interrupt Enable Register 1 (Address 00h)**

7	6	5	4	3	2	1	0
UTXIE0	URXIE0	ACCVIE	NMIIE			OFIE	WDTIE
rw-0	rw-0	rw-0	rw-0			rw-0	rw-0

**Table 6-4. Interrupt Enable Register 1 Field Descriptions**

Bit	Field	Type	Reset	Description
7	UTXIE0	RW	0h	USART0: UART and SPI transmit interrupt enable
6	URXIE0	RW	0h	USART0: UART and SPI receive interrupt enable
5	ACCVIE	RW	0h	Flash access violation interrupt enable
4	NMIIE	RW	0h	(Non)maskable interrupt enable
3-2	Unused			
1	OFIE	RW	0h	Oscillator fault interrupt enable
0	WDTIE	RW	0h	Watchdog timer interrupt enable. Inactive if watchdog mode is selected. Active if watchdog timer is configured in interval timer mode.

**Figure 6-3. Interrupt Enable Register 2 (Address 01h)**

7	6	5	4	3	2	1	0



**Figure 6-4. Interrupt Flag Register 1 (Address 02h)**

7	6	5	4	3	2	1	0
UTXIFG0	URXIFG0		NMIIFG	RSTIFG	PORIFG	OFIFG	WDTIFG
rw-1	rw-0		rw-0	rw-(0)	rw-(1)	rw-1	rw-(0)

**Table 6-5. Interrupt Flag Register 1 Field Descriptions**

Bit	Field	Type	Reset	Description
7	UTXIFG0	RW	1h	USART0: UART and SPI transmit interrupt flag
6	URXIFG0	RW	0h	USART0: UART and SPI receive interrupt flag
5	Unused			
4	NMIIFG	RW	0h	Set by $\overline{\text{RST}}$ /NMI pin
3	RSTIFG	RW	0h	Power-on reset interrupt flag. Set on $V_{CC}$ power up.
2	PORIFG	RW	1h	External reset interrupt flag. Set on a reset condition at $\overline{\text{RST}}$ /NMI pin in reset mode. Reset on $V_{CC}$ power up.
1	OFIFG	RW	1h	Flag set on oscillator fault
0	WDTIFG	RW	0h	Set on watchdog timer overflow (in watchdog mode) or security key violation. Reset on $V_{CC}$ power-up or a reset condition at $\overline{\text{RST}}$ /NMI pin in reset mode.

**Figure 6-5. Interrupt Flag Register 2 (Address 03h)**

7	6	5	4	3	2	1	0

**Figure 6-6. Module Enable Register 1 (Address 04h)**

7	6	5	4	3	2	1	0
UTXE0	URXE0 USPIE0						
rw-0	rw-0						

**Table 6-6. Module Enable Register 1 Field Descriptions**

Bit	Field	Type	Reset	Description
7	UTXE0	RW	0h	USART0: UART mode transmit enable
6	URXE0 USPIE0	RW	0h	USART0: UART mode receive enable USART0: SPI mode transmit and receive enable
5-0	Unused			

**Figure 6-7. Module Enable Register 2 (Address 05h)**

7	6	5	4	3	2	1	0

## 6.6 Memory Organization

Table 6-7 summarizes the memory map of all device variants.

Table 6-7. Memory Organization

		MSP430AFE22x	MSP430AFE23x	MSP430AFE25x
Memory Main: interrupt vector Main: code memory	Size	4KB	8KB	16KB
	Flash	FFFFh to FFE0h	FFFFh to FFE0h	FFFFh to FFE0h
	Flash	FFFFh to F000h	FFFFh to E000h	FFFFh to C000h
Information memory	Size	256 Byte	256 Byte	256 Byte
	Flash	10FFh to 1000h	10FFh to 1000h	10FFh to 1000h
RAM	Size	256 bytes	512 bytes	512 bytes
		02FFh to 0200h	03FFh to 0200h	03FFh to 0200h
Peripherals	16-bit	01FFh to 0100h	01FFh to 0100h	01FFh to 0100h
	8-bit	00FFh to 0010h	00FFh to 0010h	00FFh to 0010h
	8-bit SFR	000Fh to 0000h	000Fh to 0000h	000Fh to 0000h

## 6.7 Flash Memory

The flash memory can be programmed through the Spy-Bi-Wire or JTAG port or in-system by the CPU. The CPU can perform single-byte and single-word writes to the flash memory. Features of the flash memory include:

- Flash memory has  $n$  segments of main memory and four segments of information memory (A to D) of 64 bytes each. Each segment in main memory is 512 bytes in size.
- Segments 0 to  $n$  may be erased in one step, or each segment may be individually erased.
- Segments A to D can be erased individually, or as a group with segments 0 to  $n$ . Segments A to D are also called *information memory*.
- Segment A contains calibration data. After reset, segment A is protected against programming and erasing. It can be unlocked, but do not erase this segment if the device-specific calibration data is required.

## 6.8 Peripherals

Peripherals are connected to the CPU through data, address, and control buses. Peripherals can be managed using all instructions. For complete module descriptions, see the [MSP430x2xx Family User's Guide](#).

## 6.9 Oscillator and System Clock

The clock system is supported by the Basic Clock module that includes support for an internal digitally controlled oscillator (DCO), a high-frequency crystal oscillator, and an internal very-low-power low-frequency oscillator (VLO). The clock module is designed to meet the requirements of both low system cost and low power consumption. The internal DCO provides a fast turnon clock source and stabilizes in less than 1  $\mu$ s. The clock module provides the following clock signals:

- Auxiliary clock (ACLK), sourced from the VLO
- Main clock (MCLK), the system clock used by the CPU
- Sub-Main clock (SMCLK), the subsystem clock used by the peripheral modules

Table 6-8 lists the addresses of the available DCO calibration data.

**Table 6-8. DCO Calibration Data  
(Provided From Factory in Flash Information Memory Segment A)**

DCO FREQUENCY	CALIBRATION REGISTER	SIZE	ADDRESS
8 MHz	CALBC1_8MHZ	byte	010FDh
	CALDCO_8MHZ	byte	010FCh
12 MHz	CALBC1_12MHZ	byte	010FBh
	CALDCO_12MHZ	byte	010FAh

## 6.10 Brownout, Supply Voltage Supervisor

The brownout circuit is implemented to provide the proper internal reset signal to the device during power on and power off. The supply voltage supervisor (SVS) circuitry detects if supply voltage drops below a user-selectable level and supports both supply voltage supervision (the device is automatically reset) and supply voltage monitoring (SVM) (the device is not automatically reset).

The CPU begins code execution after the brownout circuit releases the device reset. However,  $V_{CC}$  may not have ramped to  $V_{CC(min)}$  at that time. The user must make sure that the default DCO settings are not changed until  $V_{CC}$  reaches  $V_{CC(min)}$ . If desired, the SVS circuit can be used to determine when  $V_{CC}$  reaches  $V_{CC(min)}$ .

## 6.11 Digital I/O

Two I/O ports are implemented: 8-bit port P1 and 3-bit port P2.

- All individual I/O bits are independently programmable.
- Any combination of input, output, and interrupt condition is possible.
- Edge-selectable interrupt input capability for all eight bits of port P1 and three bits of port P2.
- Read and write access to port-control registers is supported by all instructions.
- Each I/O has an individually programmable pullup or pulldown resistor.

Because there are only three I/O pins implemented from port P2, bits [5:1] of all port P2 registers read as 0, and write data is ignored.

## 6.12 Watchdog Timer (WDT+)

The primary function of the WDT+ module is to perform a controlled system restart after a software problem occurs. If the selected time interval expires, a system reset is generated. If the watchdog function is not needed in an application, the module can be disabled or configured as an interval timer and can generate interrupts at selected time intervals.

## 6.13 Timer\_A3

Timer\_A3 is a 16-bit timer/counter with three capture/compare registers. Timer\_A3 can support multiple capture/compares, PWM outputs, and interval timing (see Table 6-9). Timer\_A3 also has extensive interrupt capabilities. Interrupts may be generated from the counter on overflow conditions and from each of the capture/compare registers.

**Table 6-9. Timer\_A3 Signal Connections**

INPUT PIN NUMBER	DEVICE INPUT SIGNAL	MODULE INPUT NAME	MODULE BLOCK	MODULE OUTPUT SIGNAL	OUTPUT PIN NUMBER
24-PIN PW					24-PIN PW
12 - P1.0	TACLK	TACLK	Timer	NA	
	ACLK	ACLK			
	SMCLK	SMCLK			
12 - P1.0	$\overline{\text{TACLK}}$	INCLK			
18 - P1.2	TA0	CCI0A	CCR0	TA0	18 - P1.2
18 - P1.2	TA0	CCI0B			24 - P2.0
	DVSS	GND			
	DVCC	VCC			
17 - P1.1	TA1	CCI1A	CCR1	TA1	17 - P1.1
17 - P1.1	TA1	CCI1B			23 - P1.7
	DVSS	GND			
	DVCC	VCC			
	DVSS	CCI2A	CCR2	TA2	12 - P1.0
	ACLK (internal)	CCI2B			22 - P1.6
	DVSS	GND			
	DVCC	VCC			

## 6.14 USART0

The MSP430AFE2xx devices have one hardware universal synchronous/asynchronous receive transmit (USART0) peripheral module that is used for serial data communication. The USART0 module supports synchronous SPI (3-pin or 4-pin) and asynchronous UART communication protocols, using double-buffered transmit and receive channels. The maximum operational frequency for the USART0 module is 8 MHz.

## 6.15 Hardware Multiplier

The multiplication operation is supported by a dedicated peripheral module. The module performs 16×16-, 16×8-, 8×16-, and 8×8-bit operations. The module supports signed and unsigned multiplication as well as signed and unsigned multiply-and-accumulate operations. The result of an operation can be accessed immediately after the operands have been loaded into the peripheral registers. No additional clock cycles are required.

## 6.16 SD24\_A

The SD24\_A module integrates up to three independent 24-bit sigma-delta ADCs. Each channel is designed with fully differential analog input pair and programmable gain amplifier input stage. In addition to external analog inputs, an internal VCC sense and temperature sensor are also available.

## 6.17 Peripheral File Map

[Table 6-10](#) lists the peripheral registers with word access. [Table 6-11](#) lists the peripheral registers with byte access. Some registers are included in both tables.

**Table 6-10. Peripherals With Word Access**

PERIPHERAL	REGISTER NAME	ACRONYM	ADDRESS
Timer_A3	Capture/compare register 2	TACCR2	0176h
	Capture/compare register 1	TACCR1	0174h
	Capture/compare register 0	TACCR0	0172h
	Timer_A register	TAR	0170h
	Capture/compare control 2	TACCTL2	0166h
	Capture/compare control 1	TACCTL1	0164h
	Capture/compare control 0	TACCTL0	0162h
	Timer_A control	TACTL	0160h
	Timer_A interrupt vector	TAIV	012Eh
Hardware Multiplier	Sum extend	SUMEXT	013Eh
	Result high word	RESHI	013Ch
	Result low word	RESLO	013Ah
	Second operand	OP2	0138h
	Multiply signed + accumulate/operand 1	MACS	0136h
	Multiply + accumulate/operand 1	MAC	0134h
	Multiply signed/operand 1	MPYS	0132h
	Multiply unsigned/operand 1	MPY	0130h
Flash Memory	Flash control 3	FCTL3	012Ch
	Flash control 2	FCTL2	012Ah
	Flash control 1	FCTL1	0128h
Watchdog Timer+	Watchdog/timer control	WDTCTL	0120h
SD24_A (also see <a href="#">Table 6-11</a> )	General Control	SD24CTL	0100h
	Channel 0 Control	SD24CCTL0	0102h
	Channel 1Control	SD24CCTL1	0104h
	Channel 2 Control	SD24CCTL2	0106h
	Channel 0 conversion memory	SD24MEM0	0110h
	Channel 1 conversion memory	SD24MEM1	0112h
	Channel 2 conversion memory	SD24MEM2	0114h
	SD24 Interrupt vector word register	SD24IV	01AEh

**Table 6-11. Peripherals With Byte Access**

PERIPHERAL	REGISTER NAME	ACRONYM	ADDRESS
SD24_A (also see <a href="#">Table 6-10</a> )	Channel 0 Input Control	SD24INCTL0	00B0h
	Channel 1 Input Control	SD24INCTL1	00B1h
	Channel 2 Input Control	SD24INCTL2	00B2h
	Channel 0 Preload	SD24PRE0	00B8h
	Channel 1 Preload	SD24PRE1	00B9h
	Channel 2 Preload	SD24PRE2	00BAh
	Reserved (Internal SD24_A Configuration 1)	SD24CONF1	00BFh
USART0	Transmit buffer	U0TXBUF	0077h
	Receive buffer	U0RXBUF	0076h
	Baud rate	U0BR1	0075h
	Baud rate	U0BR0	0074h
	Modulation control	U0MCTL	0073h
	Receive control	U0RCTL	0072h
	Transmit control	U0TCTL	0071h
	USART control	U0CTL	0070h
Basic Clock System+	Basic clock system control 3	BCSCTL3	0053h
	Basic clock system control 2	BCSCTL2	0058h
	Basic clock system control 1	BCSCTL1	0057h
	DCO clock frequency control	DCOCTL	0056h
Brownout, SVS	SVS control register (reset by brownout signal)	SVSCTL	0055h
Port P2	Port P2 selection 2	P2SEL2	0042h
	Port P2 resistor enable	P2REN	002Fh
	Port P2 selection	P2SEL	002Eh
	Port P2 interrupt enable	P2IE	002Dh
	Port P2 interrupt edge select	P2IES	002Ch
	Port P2 interrupt flag	P2IFG	002Bh
	Port P2 direction	P2DIR	002Ah
	Port P2 output	P2OUT	0029h
	Port P2 input	P2IN	0028h
Port P1	Port P1 selection 2 register	P1SEL2	0041h
	Port P1 resistor enable	P1REN	0027h
	Port P1 selection	P1SEL	0026h
	Port P1 interrupt enable	P1IE	0025h
	Port P1 interrupt edge select	P1IES	0024h
	Port P1 interrupt flag	P1IFG	0023h
	Port P1 direction	P1DIR	0022h
	Port P1 output	P1OUT	0021h
	Port P1 input	P1IN	0020h
Special Function	SFR module enable 2	ME2	0005h
	SFR module enable 1	ME1	0004h
	SFR interrupt flag 2	IFG2	0003h
	SFR interrupt flag 1	IFG1	0002h
	SFR interrupt enable 2	IE2	0001h
	SFR interrupt enable 1	IE1	0000h

## 6.18 I/O Port Schematics

### 6.18.1 Port P1 Pin Schematic: P1.0 Input/Output With Schmitt Trigger

Figure 6-8 shows the port schematic. Table 6-12 summarizes the selection of the pin functions.

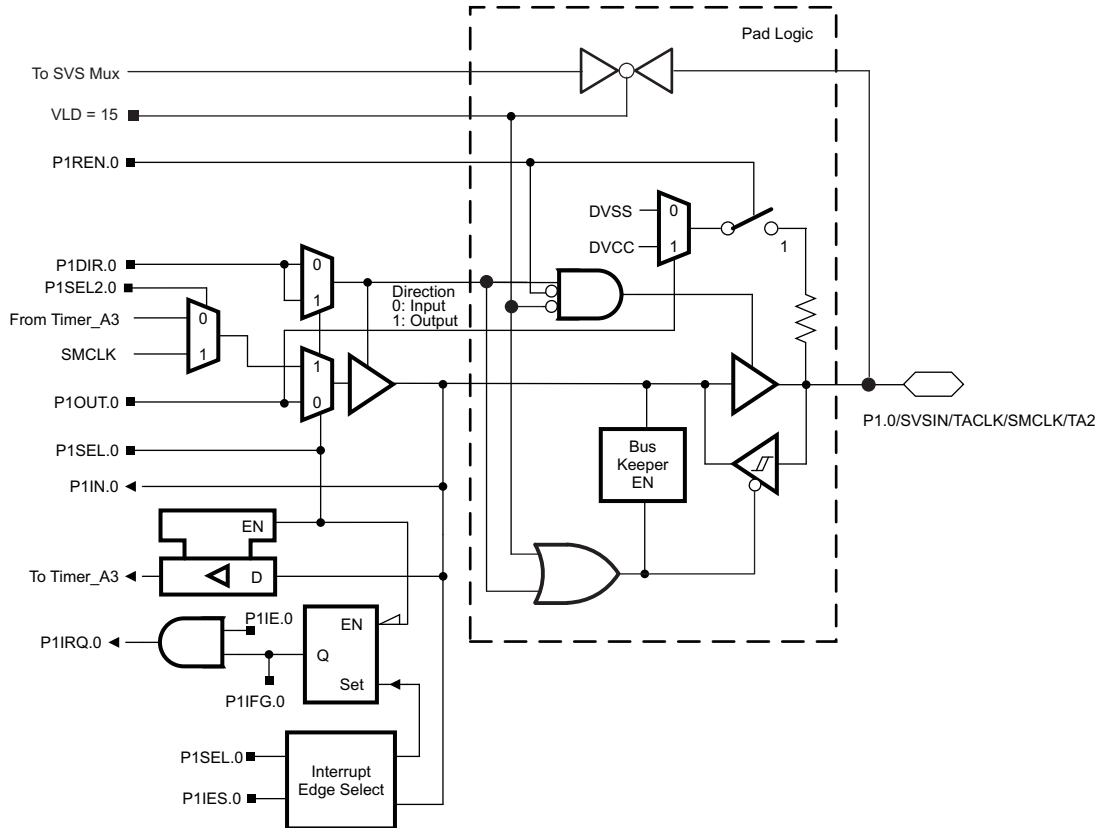

Figure 6-8. Port P1 (P1.0) Schematic

Table 6-12. Port P1 (P1.0) Pin Functions

PIN NAME (P1.x)	x	FUNCTION	CONTROL BITS OR SIGNALS <sup>(1)</sup>		
			P1DIR.x	P1SEL.x	P1SEL2.x
P1.0/SVSIN/TACLK/SMCLK/TA2	0	P1.0 (I/O)	I: 0, O: 1	0	X
		SVSIN (VLD = 15)	X	X	X
		Timer_A3.TACLK	0	1	0
		SMCLK	1	1	1
		Timer_A3.TA2	1	1	0

(1) X = don't care

### 6.18.2 Port P1 Pin Schematic: P1.1 and P1.2 Input/Output With Schmitt Trigger

Figure 6-9 shows the port schematic. Table 6-13 summarizes the selection of the pin functions.

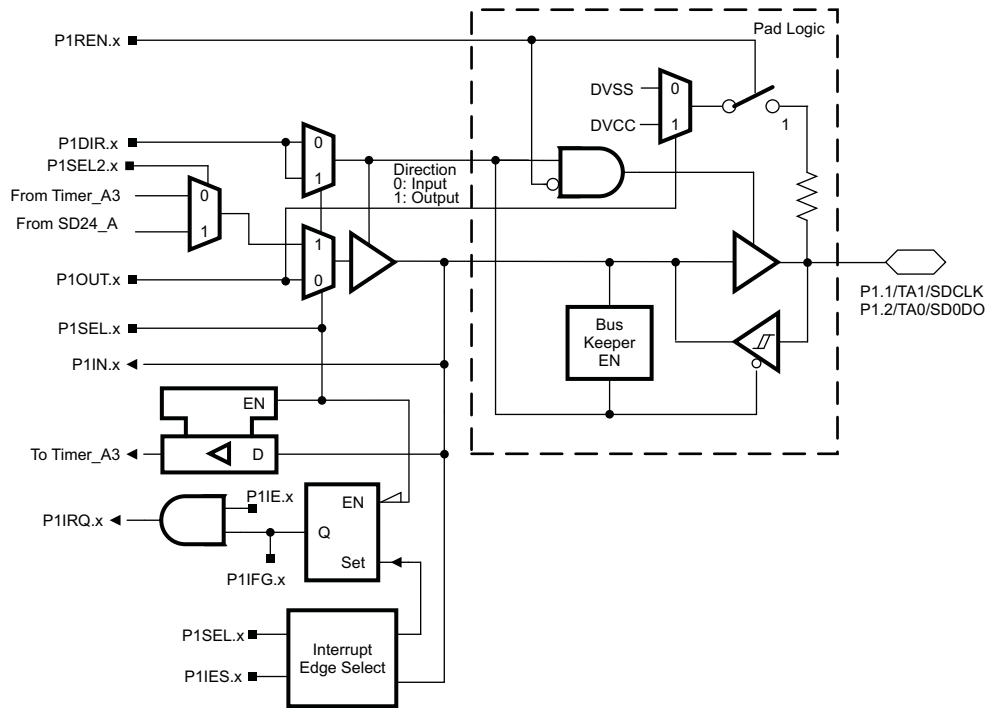

Figure 6-9. Port P1 (P1.1 and P1.2) Schematic

Table 6-13. Port P1 (P1.1 and P1.2) Pin Functions

PIN NAME (P1.x)	x	FUNCTION	CONTROL BITS / SIGNAL <sup>(1)</sup>		
			P1DIR.x	P1SEL.x	P1SEL2.x
P1.1/TA1/SDCLK	1	P1.1 (I/O)	I: 0, O: 1	0	X
		Timer_A3.CCI1A and CCI1B	0	1	0
		Timer_A3.TA1	1	1	0
		SDCLK	1	1	1
P1.2/TA0/SD0DO	2	P1.2 (I/O)	I: 0, O: 1	0	X
		Timer_A3.CCI0A and CCI0B	0	1	0
		Timer_A3.TA0	1	1	0
		SD0DO	1	1	1

(1) X = don't care



### 6.18.3 Port P1 Pin Schematic: P1.3 Input/Output With Schmitt Trigger

Figure 6-10 shows the port schematic. Table 6-14 summarizes the selection of the pin functions.

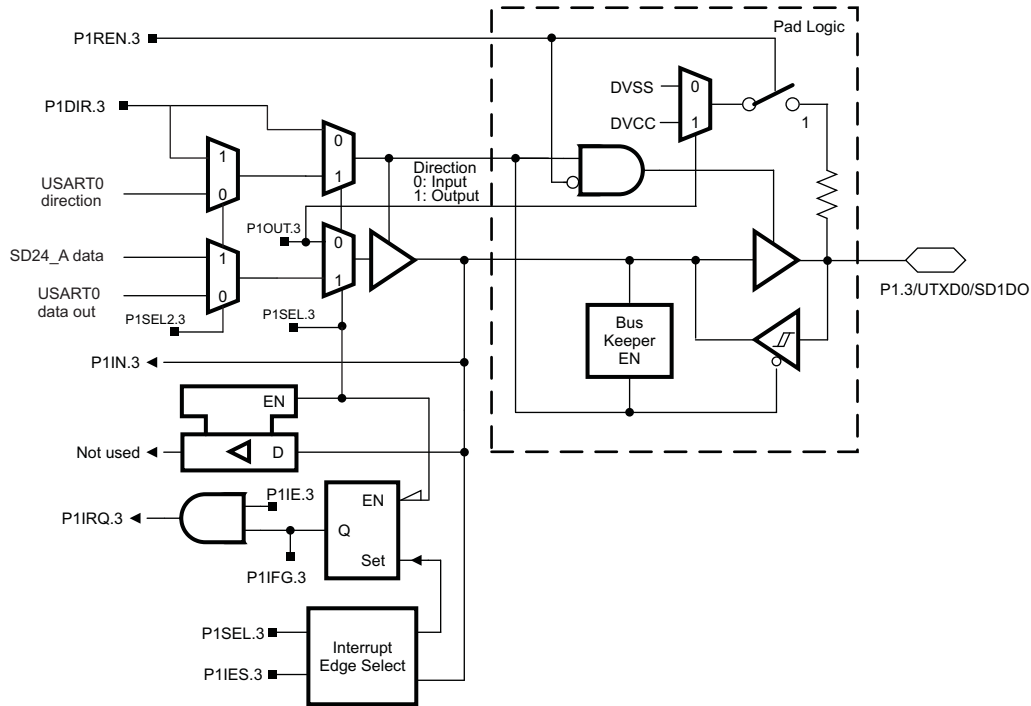

Figure 6-10. Port P1 (P1.3) Schematic

Table 6-14. Port P1 (P1.3) Pin Functions

PIN NAME (P1.x)	x	FUNCTION	CONTROL BITS OR SIGNALS <sup>(1)</sup>		
			P1DIR.x	P1SEL.x	P1SEL2.x
P1.3/UTXD0/SD1DO	3	P1.3 (I/O)	I: 0, O: 1	0	X
		UTXD0	X	1	0
		SD1DO	1	1	1

(1) X = don't care

### 6.18.4 Port P1 Pin Schematic: P1.4 Input/Output With Schmitt Trigger

Figure 6-11 shows the port schematic. Table 6-15 summarizes the selection of the pin functions.

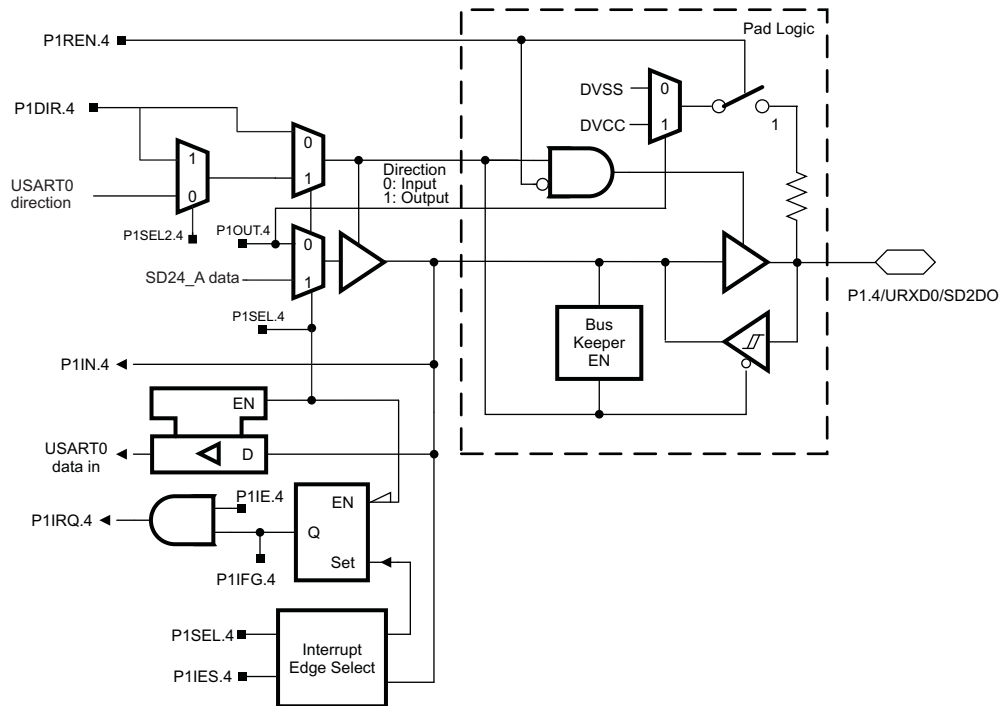

Figure 6-11. Port P1 (P1.4) Schematic

Table 6-15. Port P1 (P1.4) Pin Functions

PIN NAME (P1.x)	x	FUNCTION	CONTROL BITS OR SIGNALS <sup>(1)</sup>		
			P1DIR.x	P1SEL.x	P1SEL2.x
P1.4/URXD0/SD2DO	4	P1.4 (I/O)	I: 0, O: 1	0	X
		URXD0	X	1	0
		SD2DO	1	1	1

(1) X = don't care

### 6.18.5 Port P1 Pin Schematic: P1.5 to P1.7 Input/Output With Schmitt Trigger

Figure 6-12 shows the port schematic. Table 6-16 summarizes the selection of the pin functions.

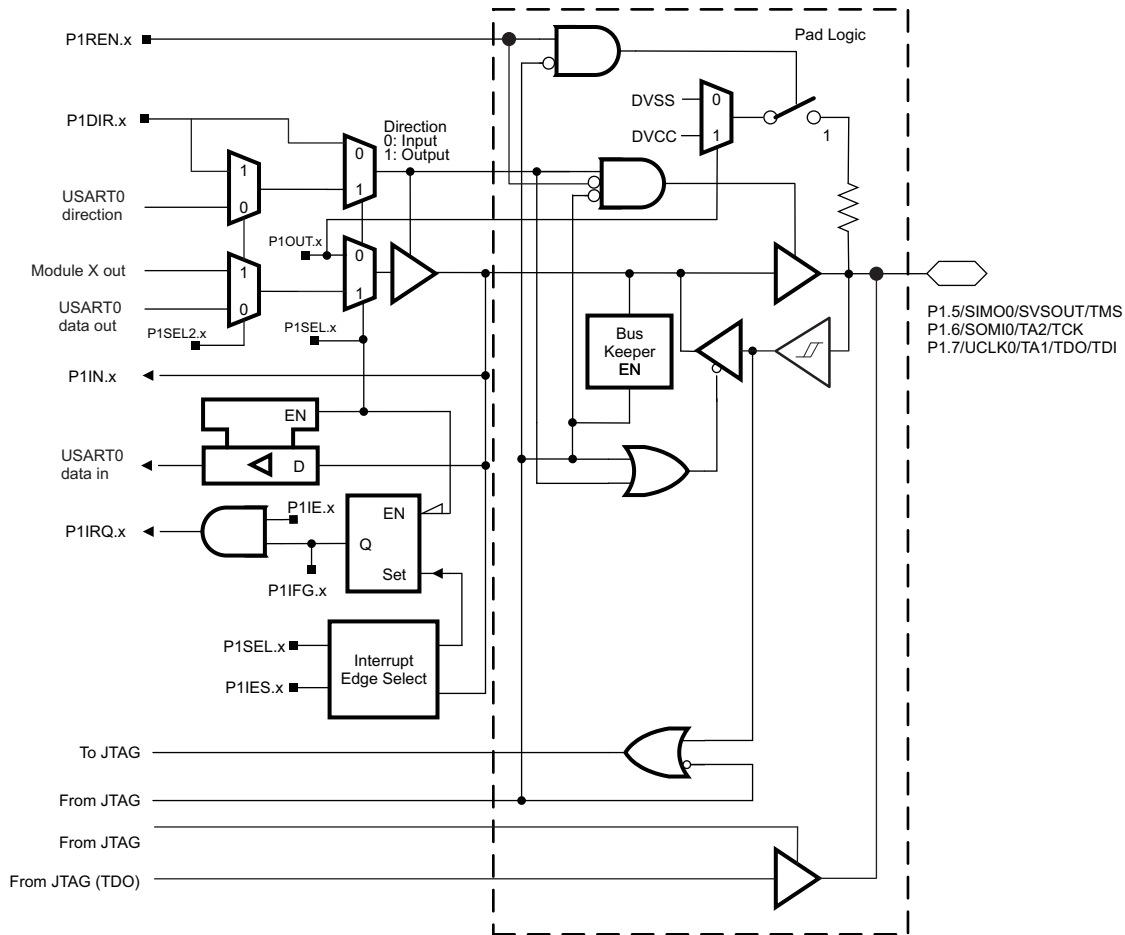

Figure 6-12. Port P1 (P1.5 to P1.7) Schematic

Table 6-16. Port P1 (P1.5 to P1.7) Pin Functions

PIN NAME (P1.x)	x	FUNCTION	CONTROL BITS OR SIGNALS <sup>(1)</sup>			
			P1DIR.x	P1SEL.x	P1SEL2.x	JTAG Mode <sup>(2)</sup>
P1.5/SIMO0/SVSOUT/TMS	5	P1.5 (I/O)	I: 0; O: 1	0	X	0
		SIMO0	X	1	0	0
		SVSOUT	1	1	1	0
		TMS	X	X	X	1
P1.6/SOMI0/TA2/TCK	6	P1.6 (I/O)	I: 0; O: 1	0	X	0
		SOMI0	X	1	0	0
		Timer_A3.TA2	1	1	1	0
		TCK	X	X	X	1
P1.7/UCLK0/TA1/TDO/TDI	7	P1.7 (I/O)	I: 0; O: 1	0	X	0
		UCLK0	X	1	0	0
		Timer_A3.TA1	1	1	1	0
		TDO/TDI	X	X	X	1

(1) X = don't care

(2) JTAG Mode is not a register bit but signal generated internally when the 4-wire JTAG option is selected in the IDE.

### 6.18.6 Port P2 Pin Schematic: P2.0 Input/Output With Schmitt Trigger

Figure 6-13 shows the port schematic. Table 6-17 summarizes the selection of the pin functions.

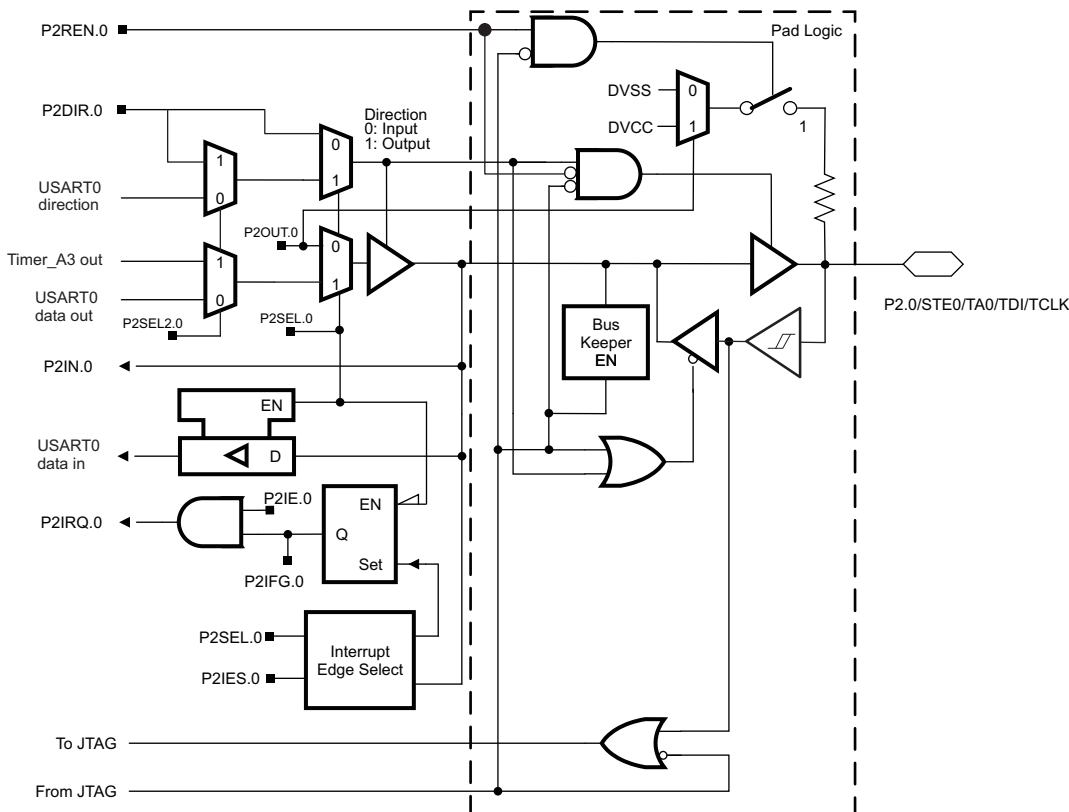

Figure 6-13. Port P2 (P2.0) Schematic

Table 6-17. Port P2 (P2.0) Pin Functions

PIN NAME (P2.x)	x	FUNCTION	CONTROL BITS OR SIGNALS <sup>(1)</sup>			
			P2DIR.x	P2SEL.x	P2SEL2.x	JTAG Mode <sup>(2)</sup>
P2.0/STE0/TA0/TDI/TCLK	0	P2.0 (I/O)	I: 0; O: 1	0	X	0
		STE0	X	1	0	0
		Timer_A3.TA0	1	1	1	0
		TDI/TCLK	X	X	X	1

(1) X = don't care

(2) JTAG Mode is not a register bit but signal generated internally when the 4-wire JTAG option is selected in the IDE.

### 6.18.7 Port P2 Pin Schematic: P2.6, Input/Output With Schmitt Trigger

Figure 6-14 shows the port schematic. Table 6-18 summarizes the selection of the pin functions.

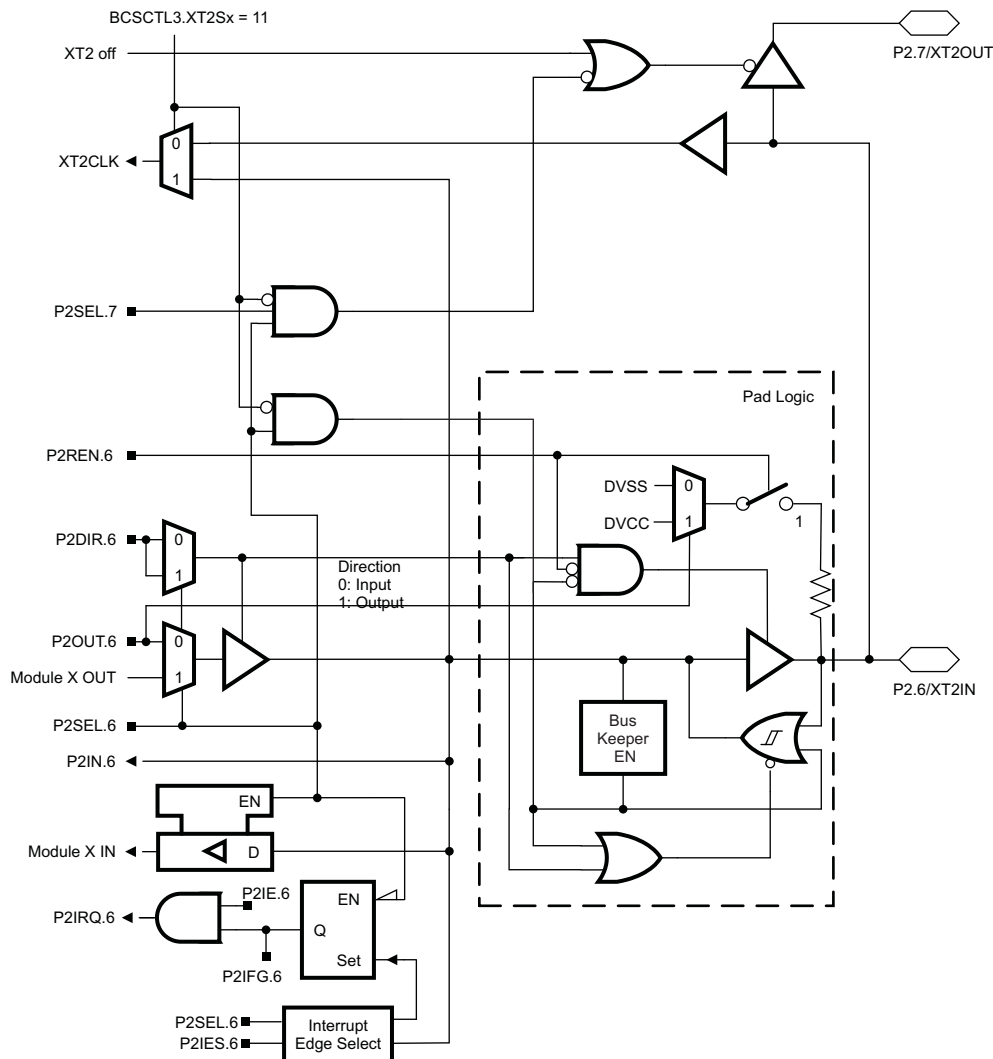

Figure 6-14. Port P2 (P2.6) Schematic

Table 6-18. Port P2 (P2.6) Pin Functions

Pin Name (P2.x)	x	FUNCTION	CONTROL BITS OR SIGNALS	
			P2DIR.6	P2SEL.6
P2.6/XT2IN	6	P2.6 (I/O)	I: 0; O: 1	0
		XT2IN (default)	0	1

### 6.18.8 Port P2 Pin Schematic: P2.7, Input/Output With Schmitt Trigger

Figure 6-15 shows the port schematic. Table 6-19 summarizes the selection of the pin functions.

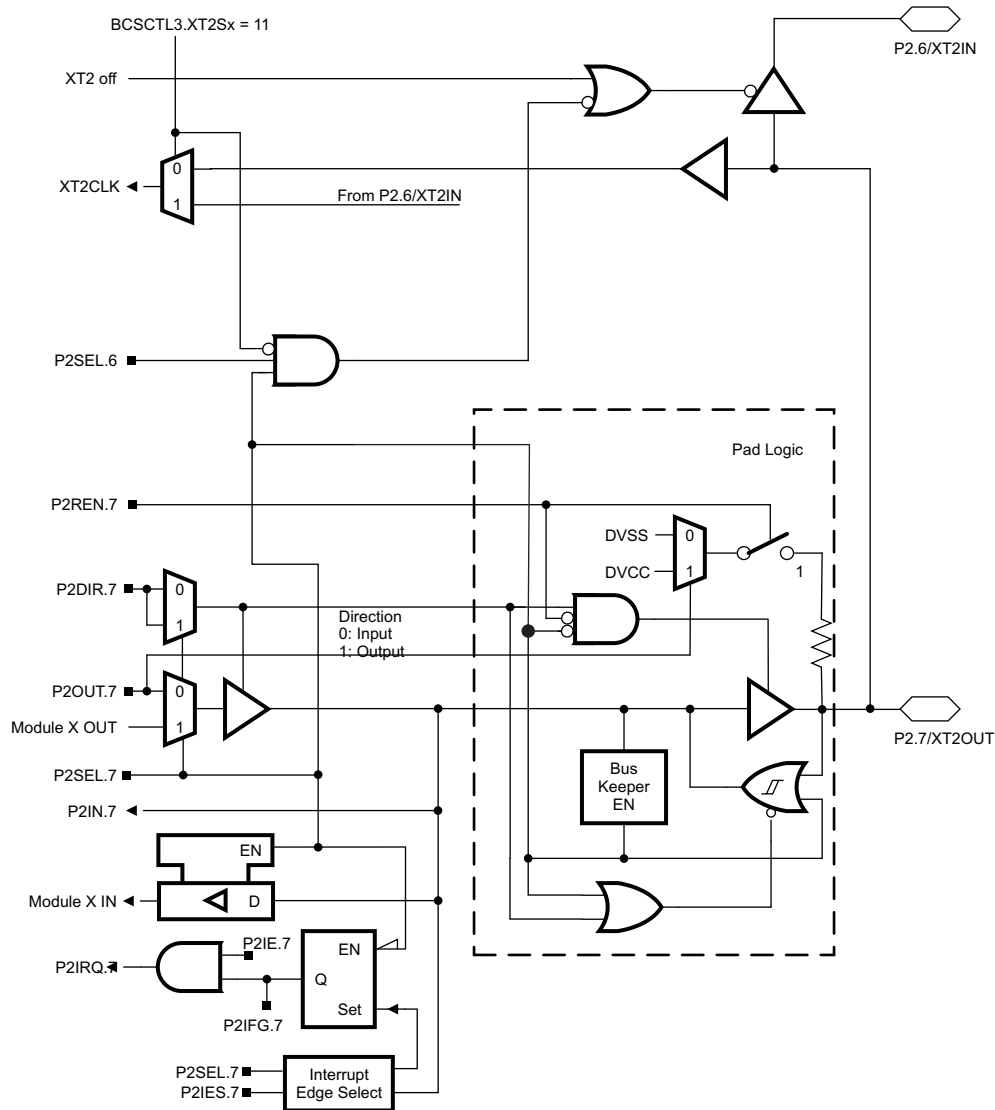

Figure 6-15. Port P2 (P2.7) Schematic

Table 6-19. Port P2 (P2.7) Pin Functions

PIN NAME (P2.x)	x	FUNCTION	CONTROL BITS OR SIGNALS	
			P2DIR.7	P2SEL.7
P2.7/XT2OUT	7	P2.7 (I/O)	I: 0, O: 1	0
		XT2OUT (default)	0	1

### 6.18.9 JTAG Fuse Check Mode

MSP430 devices that have the fuse on the TEST terminal have a fuse check mode that tests the continuity of the fuse the first time the JTAG port is accessed after a power-on reset (POR). When activated, a fuse check current,  $I_{TF}$ , of 1 mA at 3 V or 2.5 mA at 5 V can flow from the TEST pin to ground if the fuse is not burned. Care must be taken to avoid accidentally activating the fuse check mode and increasing overall system power consumption.

When the TEST pin is again taken low after a test or programming session, the fuse check mode and sense currents are terminated.

Activation of the fuse check mode occurs with the first negative edge on the TMS pin after power up or if TMS is being held low during power up. The second positive edge on the TMS pin deactivates the fuse check mode. After deactivation, the fuse check mode remains inactive until another POR occurs. After each POR, the fuse check mode has the potential to be activated.

The fuse check current flow only when the fuse check mode is active and the TMS pin is in a low state (see Figure 6-16). Therefore, the additional current flow can be prevented by holding the TMS pin high (default condition).

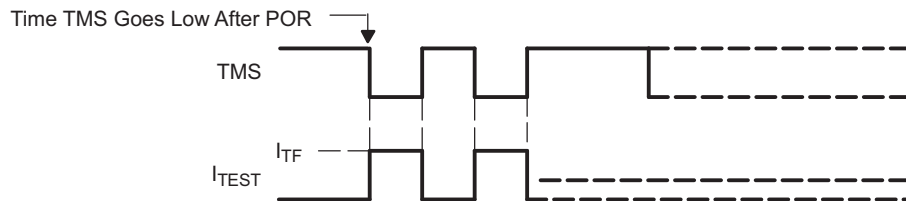

**Figure 6-16. Fuse Check Mode Current**

#### NOTE

The CODE and RAM data protection is ensured if the JTAG fuse is blown.

## 7 Device and Documentation Support

### 7.1 Getting Started

For more information on the MSP430™ family of devices and the tools and libraries that are available to help with your development, visit the [overview page](#).

### 7.2 Device Nomenclature

To designate the stages in the product development cycle, TI assigns prefixes to the part numbers of all MSP430 MCU devices and support tools. Each MSP430 MCU commercial family member has one of three prefixes: MSP, PMS, or XMS (for example, MSP430F5438A). TI recommends two of three possible prefix designators for its support tools: MSP and MSPX. These prefixes represent evolutionary stages of product development from engineering prototypes (with XMS for devices and MSPX for tools) through fully qualified production devices and tools (with MSP for devices and MSP for tools).

Device development evolutionary flow:

**XMS** – Experimental device that is not necessarily representative of the electrical specifications for the final device

**PMS** – Final silicon die that conforms to the electrical specifications for the device but has not completed quality and reliability verification

**MSP** – Fully qualified production device

Support tool development evolutionary flow:

**MSPX** – Development-support product that has not yet completed TI's internal qualification testing.

**MSP** – Fully-qualified development-support product

XMS and PMS devices and MSPX development-support tools are shipped against the following disclaimer:

"Developmental product is intended for internal evaluation purposes."

MSP devices and MSP development-support tools have been characterized fully, and the quality and reliability of the device have been demonstrated fully. TI's standard warranty applies.

Predictions show that prototype devices (XMS and PMS) have a greater failure rate than the standard production devices. TI recommends that these devices not be used in any production system because their expected end-use failure rate still is undefined. Only qualified production devices are to be used.

TI device nomenclature also includes a suffix with the device family name. This suffix indicates the package type (for example, PZP) and temperature range (for example, T). [Figure 7-1](#) provides a legend for reading the complete device name for any family member.



**Figure 7-1. Device Nomenclature**

### 7.3 Tools and Software

All MSP microcontrollers are supported by a wide variety of software and hardware development tools. Tools are available from TI and various third parties. See them all at [Development Kits and Software for Low-Power MCUs](#).

Table 7-1 lists the debug features of the MSP430AFE2xx MCUs. See the [Code Composer Studio for MSP430 User's Guide](#) for details on the available features.

**Table 7-1. Hardware Debug Features**

MSP430 ARCHITECTURE	4-WIRE JTAG	2-WIRE JTAG	BREAK-POINTS (N)	RANGE BREAK-POINTS	CLOCK CONTROL	STATE SEQUENCER	TRACE BUFFER
MSP430	Yes	Yes	2	No	Yes	No	No

#### Design Kits and Evaluation Modules

**MSP-TS430PW24 - 24-pin Target Development Board for MSP430AFEx MCUs** The MSP-TS430PW24 is a stand-alone ZIF socket target board used to program and debug the MSP430 MCU in-system through the JTAG interface or the Spy-Bi-Wire (2-wire JTAG) protocol.

**MSP430AFE253 embedded metering (sub-meter) EVM** This embedded metering (sub-meter/e-meter) EVM is designed based on the MSP430AFE253. The EVM can be connected to the mains (or to DC) and the load directly. The EVM measures the electrical parameters of the load and the result of measurement can be read from the UART port. This EVM provided with built-in power supply and isolated serial connect to facilitate user quick start to the evaluation of the MSP430AFE253 in embedded metering application.

#### Software

**MSP430Ware™ Software** MSP430Ware software is a collection of code examples, data sheets, and other design resources for all MSP430 devices delivered in a convenient package. In addition to providing a complete collection of existing MSP430 MCU design resources, MSP430Ware software also includes a high-level API called MSP Driver Library. This library makes it easy to program MSP430 hardware. MSP430Ware software is available as a component of CCS or as a stand-alone package.

**MSP430AFE2x3, MSP430AFE2x2, MSP430AFE2x1 Code Examples** C code examples are available for every MSP device that configures each of the integrated peripherals for various application needs.

**Fixed Point Math Library for MSP** The TI MSP IQmath and Qmath Libraries are a collection of highly optimized and high-precision mathematical functions for C programmers to seamlessly port a floating-point algorithm into fixed-point code on MSP430 and MSP432 devices. These routines are typically used in computationally intensive real-time applications where optimal execution speed, high accuracy and ultra-low energy are critical. By using the IQmath and Qmath libraries, it is possible to achieve execution speeds considerably faster and energy consumption considerably lower than equivalent code written using floating-point math.

**Digital Signal Processing (DSP) Library for MSP Microcontrollers** The Digital Signal Processing library is a set of highly optimized functions to perform many common signal processing operations on fixed-point numbers for MSP430 microcontrollers. This function set is typically utilized for applications where processing-intensive transforms are done in real-time for minimal energy and with very high accuracy. This library's optimal use of the MSP families' intrinsic hardware for fixed-point math allows for significant performance gains.

#### Development Tools

**Code Composer Studio™ Integrated Development Environment for MSP Microcontrollers** Code Composer Studio (CCS) integrated development environment (IDE) supports all MSP microcontroller devices. CCS comprises a suite of embedded software utilities used to develop and debug embedded applications. CCS includes an optimizing C/C++ compiler, source code editor, project build environment, debugger, profiler, and many other features.

**MSP Flasher - Command Line Programmer** MSP Flasher is an open-source shell-based interface for programming MSP microcontrollers through a FET programmer or eZ430 using JTAG or Spy-Bi-Wire (SBW) communication. MSP Flasher can download binary files (.txt or .hex) directly to the MSP microcontroller without an IDE.

**MSP MCU Programmer and Debugger** The MSP-FET is a powerful emulation development tool – often called a debug probe – which lets users quickly begin application development on MSP low-power MCUs. Creating MCU software usually requires downloading the resulting binary program to the MSP device for validation and debugging.

**MSP-GANG Production Programmer** The MSP Gang Programmer is an MSP430 or MSP432 device programmer that can program up to eight identical MSP430 or MSP432 flash or FRAM devices at the same time. The MSP Gang Programmer connects to a host PC using a standard RS-232 or USB connection and provides flexible programming options that let the user fully customize the process.

## 7.4 Documentation Support

The following documents describe the MSP430AFE2xx MCUs. Copies of these documents are available on the Internet at [www.ti.com](http://www.ti.com).

### Receiving Notification of Document Updates

To receive notification of documentation updates—including silicon errata—go to the product folder for your device on [ti.com](http://ti.com) (for links to product folders, see [Section 7.5](#)). In the upper right corner, click the "Alert me" button. This registers you to receive a weekly digest of product information that has changed (if any). For change details, check the revision history of any revised document.

### Errata

**MSP430AFE253 Device Erratasheet** Describes the known exceptions to the functional specifications.

**MSP430AFE252 Device Erratasheet** Describes the known exceptions to the functional specifications.

**MSP430AFE251 Device Erratasheet** Describes the known exceptions to the functional specifications.

**MSP430AFE233 Device Erratasheet** Describes the known exceptions to the functional specifications.

**MSP430AFE232 Device Erratasheet** Describes the known exceptions to the functional specifications.

**MSP430AFE231 Device Erratasheet** Describes the known exceptions to the functional specifications.

**MSP430AFE223 Device Erratasheet** Describes the known exceptions to the functional specifications.

**MSP430AFE222 Device Erratasheet** Describes the known exceptions to the functional specifications.

**MSP430AFE221 Device Erratasheet** Describes the known exceptions to the functional specifications.

### User's Guides

**MSP430x2xx Family User's Guide** Detailed information on the modules and peripherals available in this device family.

**MSP430 Programming With the Bootloader (BSL)** The MSP430 bootloader (BSL) (formerly known as the bootstrap loader) lets users communicate with embedded memory in the MSP430 microcontroller during the prototyping phase, final production, and in service. Both the programmable memory (flash memory) and the data memory (RAM) can be modified as required. Do not confuse the bootloader with the bootstrap loader programs found in some digital signal processors (DSPs) that automatically load program code (and data) from external memory to the internal memory of the DSP.

**MSP430 Programming With the JTAG Interface** This document describes the functions that are required to erase, program, and verify the memory module of the MSP430 flash-based and FRAM-based microcontroller families using the JTAG communication port. In addition, it describes how to program the JTAG access security fuse that is available on all MSP430 devices. This document describes device access using both the standard 4-wire JTAG interface and the 2-wire JTAG interface, which is also referred to as Spy-Bi-Wire (SBW).

**MSP430 Hardware Tools User's Guide** This manual describes the hardware of the TI MSP-FET430 Flash Emulation Tool (FET). The FET is the program development tool for the MSP430 ultra-low-power microcontroller. Both available interface types, the parallel port interface and the USB interface, are described.

### Application Reports

**MSP430 32-kHz Crystal Oscillators** Selection of the correct crystal, correct load circuit, and proper board layout are important for a stable crystal oscillator. This application report summarizes crystal oscillator function and explains the parameters to select the correct crystal for MSP430 ultra-low-power operation. In addition, hints and examples for correct board layout are given. The document also contains detailed information on the possible oscillator tests to ensure stable oscillator operation in mass production.

**MSP430 System-Level ESD Considerations** System-Level ESD has become increasingly demanding with silicon technology scaling towards lower voltages and the need for designing cost-effective and ultra-low-power components. This application report addresses three different ESD topics to help board designers and OEMs understand and design robust system-level designs.

## 7.5 Related Links

Table 7-2 lists quick access links. Categories include technical documents, support and community resources, tools and software, and quick access to sample or buy.

Table 7-2. Related Links

PARTS	PRODUCT FOLDER	ORDER NOW	TECHNICAL DOCUMENTS	TOOLS & SOFTWARE	SUPPORT & COMMUNITY
MSP430AFE253	<a href="#">Click here</a>	<a href="#">Click here</a>	<a href="#">Click here</a>	<a href="#">Click here</a>	<a href="#">Click here</a>
MSP430AFE252	<a href="#">Click here</a>	<a href="#">Click here</a>	<a href="#">Click here</a>	<a href="#">Click here</a>	<a href="#">Click here</a>
MSP430AFE251	<a href="#">Click here</a>	<a href="#">Click here</a>	<a href="#">Click here</a>	<a href="#">Click here</a>	<a href="#">Click here</a>
MSP430AFE233	<a href="#">Click here</a>	<a href="#">Click here</a>	<a href="#">Click here</a>	<a href="#">Click here</a>	<a href="#">Click here</a>
MSP430AFE232	<a href="#">Click here</a>	<a href="#">Click here</a>	<a href="#">Click here</a>	<a href="#">Click here</a>	<a href="#">Click here</a>
MSP430AFE231	<a href="#">Click here</a>	<a href="#">Click here</a>	<a href="#">Click here</a>	<a href="#">Click here</a>	<a href="#">Click here</a>
MSP430AFE223	<a href="#">Click here</a>	<a href="#">Click here</a>	<a href="#">Click here</a>	<a href="#">Click here</a>	<a href="#">Click here</a>
MSP430AFE222	<a href="#">Click here</a>	<a href="#">Click here</a>	<a href="#">Click here</a>	<a href="#">Click here</a>	<a href="#">Click here</a>
MSP430AFE221	<a href="#">Click here</a>	<a href="#">Click here</a>	<a href="#">Click here</a>	<a href="#">Click here</a>	<a href="#">Click here</a>

## 7.6 Community Resources

The following links connect to TI community resources. Linked contents are provided "AS IS" by the respective contributors. They do not constitute TI specifications and do not necessarily reflect TI's views; see TI's [Terms of Use](#).

### TI E2E™ Community

TI's *Engineer-to-Engineer (E2E) Community*. Created to foster collaboration among engineers. At [e2e.ti.com](http://e2e.ti.com), you can ask questions, share knowledge, explore ideas, and help solve problems with fellow engineers.

### TI Embedded Processors Wiki

*Texas Instruments Embedded Processors Wiki*. Established to help developers get started with embedded processors from Texas Instruments and to foster innovation and growth of general knowledge about the hardware and software surrounding these devices.

## 7.7 Trademarks

MSP430, MSP430Ware, Code Composer Studio, E2E are trademarks of Texas Instruments. All other trademarks are the property of their respective owners.

## 7.8 Electrostatic Discharge Caution



This integrated circuit can be damaged by ESD. Texas Instruments recommends that all integrated circuits be handled with appropriate precautions. Failure to observe proper handling and installation procedures can cause damage.

ESD damage can range from subtle performance degradation to complete device failure. Precision integrated circuits may be more susceptible to damage because very small parametric changes could cause the device not to meet its published specifications.

## 7.9 Glossary

[TI Glossary](#) This glossary lists and explains terms, acronyms, and definitions.

## 8 Mechanical, Packaging, and Orderable Information

The following pages include mechanical, packaging, and orderable information. This information is the most current data available for the designated devices. This data is subject to change without notice and revision of this document. For browser-based versions of this data sheet, refer to the left-hand navigation.

**PACKAGING INFORMATION**

Orderable Device	Status (1)	Package Type	Package Drawing	Pins	Package Qty	Eco Plan (2)	Lead finish/ Ball material (6)	MSL Peak Temp (3)	Op Temp (°C)	Device Marking (4/5)	Samples
MSP4301103IPWR	ACTIVE	TSSOP	PW	24	2000	RoHS & Green	NIPDAU	Level-1-260C-UNLIM	-40 to 85	430AFE253	<a href="#">Samples</a>
MSP430AFE221IPW	ACTIVE	TSSOP	PW	24	60	RoHS & Green	NIPDAU	Level-1-260C-UNLIM	-40 to 85	430AFE221	<a href="#">Samples</a>
MSP430AFE221IPWR	ACTIVE	TSSOP	PW	24	2000	RoHS & Green	NIPDAU	Level-1-260C-UNLIM	-40 to 85	430AFE221	<a href="#">Samples</a>
MSP430AFE222IPW	ACTIVE	TSSOP	PW	24	60	RoHS & Green	NIPDAU	Level-1-260C-UNLIM	-40 to 85	430AFE222	<a href="#">Samples</a>
MSP430AFE222IPWR	ACTIVE	TSSOP	PW	24	2000	RoHS & Green	NIPDAU	Level-1-260C-UNLIM	-40 to 85	430AFE222	<a href="#">Samples</a>
MSP430AFE223IPW	ACTIVE	TSSOP	PW	24	60	RoHS & Green	NIPDAU	Level-1-260C-UNLIM	-40 to 85	430AFE223	<a href="#">Samples</a>
MSP430AFE223IPWR	ACTIVE	TSSOP	PW	24	2000	RoHS & Green	NIPDAU	Level-1-260C-UNLIM	-40 to 85	430AFE223	<a href="#">Samples</a>
MSP430AFE231IPW	ACTIVE	TSSOP	PW	24	60	RoHS & Green	NIPDAU	Level-1-260C-UNLIM	-40 to 85	430AFE231	<a href="#">Samples</a>
MSP430AFE231IPWR	ACTIVE	TSSOP	PW	24	2000	RoHS & Green	NIPDAU	Level-1-260C-UNLIM	-40 to 85	430AFE231	<a href="#">Samples</a>
MSP430AFE232IPW	ACTIVE	TSSOP	PW	24	60	RoHS & Green	NIPDAU	Level-1-260C-UNLIM	-40 to 85	430AFE232	<a href="#">Samples</a>
MSP430AFE232IPWR	ACTIVE	TSSOP	PW	24	2000	RoHS & Green	NIPDAU	Level-1-260C-UNLIM	-40 to 85	430AFE232	<a href="#">Samples</a>
MSP430AFE233IPW	ACTIVE	TSSOP	PW	24	60	RoHS & Green	NIPDAU	Level-1-260C-UNLIM	-40 to 85	430AFE233	<a href="#">Samples</a>
MSP430AFE233IPWR	ACTIVE	TSSOP	PW	24	2000	RoHS & Green	NIPDAU	Level-1-260C-UNLIM	-40 to 85	430AFE233	<a href="#">Samples</a>
MSP430AFE251IPW	ACTIVE	TSSOP	PW	24	60	RoHS & Green	NIPDAU	Level-1-260C-UNLIM	-40 to 85	430AFE251	<a href="#">Samples</a>
MSP430AFE251IPWR	ACTIVE	TSSOP	PW	24	2000	RoHS & Green	NIPDAU	Level-1-260C-UNLIM	-40 to 85	430AFE251	<a href="#">Samples</a>
MSP430AFE252IPW	ACTIVE	TSSOP	PW	24	60	RoHS & Green	NIPDAU	Level-1-260C-UNLIM	-40 to 85	430AFE252	<a href="#">Samples</a>
MSP430AFE252IPWR	ACTIVE	TSSOP	PW	24	2000	RoHS & Green	NIPDAU	Level-1-260C-UNLIM	-40 to 85	430AFE252	<a href="#">Samples</a>
MSP430AFE253IPW	ACTIVE	TSSOP	PW	24	60	RoHS & Green	NIPDAU	Level-1-260C-UNLIM	-40 to 85	430AFE253	<a href="#">Samples</a>
MSP430AFE253IPWR	ACTIVE	TSSOP	PW	24	2000	RoHS & Green	NIPDAU	Level-1-260C-UNLIM	-40 to 85	430AFE253	<a href="#">Samples</a>

<sup>(1)</sup> The marketing status values are defined as follows:



---

**ACTIVE:** Product device recommended for new designs.

**LIFEBUY:** TI has announced that the device will be discontinued, and a lifetime-buy period is in effect.

**NRND:** Not recommended for new designs. Device is in production to support existing customers, but TI does not recommend using this part in a new design.

**PREVIEW:** Device has been announced but is not in production. Samples may or may not be available.

**OBSOLETE:** TI has discontinued the production of the device.

<sup>(2)</sup> **RoHS:** TI defines "RoHS" to mean semiconductor products that are compliant with the current EU RoHS requirements for all 10 RoHS substances, including the requirement that RoHS substance do not exceed 0.1% by weight in homogeneous materials. Where designed to be soldered at high temperatures, "RoHS" products are suitable for use in specified lead-free processes. TI may reference these types of products as "Pb-Free".

**RoHS Exempt:** TI defines "RoHS Exempt" to mean products that contain lead but are compliant with EU RoHS pursuant to a specific EU RoHS exemption.

**Green:** TI defines "Green" to mean the content of Chlorine (Cl) and Bromine (Br) based flame retardants meet JS709B low halogen requirements of  $\leq 1000$ ppm threshold. Antimony trioxide based flame retardants must also meet the  $\leq 1000$ ppm threshold requirement.

<sup>(3)</sup> MSL, Peak Temp. - The Moisture Sensitivity Level rating according to the JEDEC industry standard classifications, and peak solder temperature.

<sup>(4)</sup> There may be additional marking, which relates to the logo, the lot trace code information, or the environmental category on the device.

<sup>(5)</sup> Multiple Device Markings will be inside parentheses. Only one Device Marking contained in parentheses and separated by a "~" will appear on a device. If a line is indented then it is a continuation of the previous line and the two combined represent the entire Device Marking for that device.

<sup>(6)</sup> Lead finish/Ball material - Orderable Devices may have multiple material finish options. Finish options are separated by a vertical ruled line. Lead finish/Ball material values may wrap to two lines if the finish value exceeds the maximum column width.

**Important Information and Disclaimer:** The information provided on this page represents TI's knowledge and belief as of the date that it is provided. TI bases its knowledge and belief on information provided by third parties, and makes no representation or warranty as to the accuracy of such information. Efforts are underway to better integrate information from third parties. TI has taken and continues to take reasonable steps to provide representative and accurate information but may not have conducted destructive testing or chemical analysis on incoming materials and chemicals. TI and TI suppliers consider certain information to be proprietary, and thus CAS numbers and other limited information may not be available for release.

In no event shall TI's liability arising out of such information exceed the total purchase price of the TI part(s) at issue in this document sold by TI to Customer on an annual basis.



**TAPE AND REEL INFORMATION**

**QUADRANT ASSIGNMENTS FOR PIN 1 ORIENTATION IN TAPE**

\*All dimensions are nominal

Device	Package Type	Package Drawing	Pins	SPQ	Reel Diameter (mm)	Reel Width W1 (mm)	A0 (mm)	B0 (mm)	K0 (mm)	P1 (mm)	W (mm)	Pin1 Quadrant
MSP430AFE221IPWR	TSSOP	PW	24	2000	330.0	16.4	6.95	8.3	1.6	8.0	16.0	Q1
MSP430AFE222IPWR	TSSOP	PW	24	2000	330.0	16.4	6.95	8.3	1.6	8.0	16.0	Q1
MSP430AFE223IPWR	TSSOP	PW	24	2000	330.0	16.4	6.95	8.3	1.6	8.0	16.0	Q1
MSP430AFE231IPWR	TSSOP	PW	24	2000	330.0	16.4	6.95	8.3	1.6	8.0	16.0	Q1
MSP430AFE232IPWR	TSSOP	PW	24	2000	330.0	16.4	6.95	8.3	1.6	8.0	16.0	Q1
MSP430AFE233IPWR	TSSOP	PW	24	2000	330.0	16.4	6.95	8.3	1.6	8.0	16.0	Q1
MSP430AFE251IPWR	TSSOP	PW	24	2000	330.0	16.4	6.95	8.3	1.6	8.0	16.0	Q1
MSP430AFE252IPWR	TSSOP	PW	24	2000	330.0	16.4	6.95	8.3	1.6	8.0	16.0	Q1
MSP430AFE253IPWR	TSSOP	PW	24	2000	330.0	16.4	6.95	8.3	1.6	8.0	16.0	Q1

**TAPE AND REEL BOX DIMENSIONS**

\*All dimensions are nominal

Device	Package Type	Package Drawing	Pins	SPQ	Length (mm)	Width (mm)	Height (mm)
MSP430AFE221IPWR	TSSOP	PW	24	2000	350.0	350.0	43.0
MSP430AFE222IPWR	TSSOP	PW	24	2000	350.0	350.0	43.0
MSP430AFE223IPWR	TSSOP	PW	24	2000	350.0	350.0	43.0
MSP430AFE231IPWR	TSSOP	PW	24	2000	350.0	350.0	43.0
MSP430AFE232IPWR	TSSOP	PW	24	2000	350.0	350.0	43.0
MSP430AFE233IPWR	TSSOP	PW	24	2000	350.0	350.0	43.0
MSP430AFE251IPWR	TSSOP	PW	24	2000	350.0	350.0	43.0
MSP430AFE252IPWR	TSSOP	PW	24	2000	350.0	350.0	43.0
MSP430AFE253IPWR	TSSOP	PW	24	2000	350.0	350.0	43.0

**TUBE**

\*All dimensions are nominal

Device	Package Name	Package Type	Pins	SPQ	L (mm)	W (mm)	T (μm)	B (mm)
MSP430AFE221IPW	PW	TSSOP	24	60	530	10.2	3600	3.5
MSP430AFE222IPW	PW	TSSOP	24	60	530	10.2	3600	3.5
MSP430AFE223IPW	PW	TSSOP	24	60	530	10.2	3600	3.5
MSP430AFE231IPW	PW	TSSOP	24	60	530	10.2	3600	3.5
MSP430AFE232IPW	PW	TSSOP	24	60	530	10.2	3600	3.5
MSP430AFE233IPW	PW	TSSOP	24	60	530	10.2	3600	3.5
MSP430AFE251IPW	PW	TSSOP	24	60	530	10.2	3600	3.5
MSP430AFE252IPW	PW	TSSOP	24	60	530	10.2	3600	3.5
MSP430AFE253IPW	PW	TSSOP	24	60	530	10.2	3600	3.5

PW0024A



# PACKAGE OUTLINE

## TSSOP - 1.2 mm max height

SMALL OUTLINE PACKAGE



4220208/A 02/2017

### NOTES:

1. All linear dimensions are in millimeters. Any dimensions in parenthesis are for reference only. Dimensioning and tolerancing per ASME Y14.5M.
2. This drawing is subject to change without notice.
3. This dimension does not include mold flash, protrusions, or gate burrs. Mold flash, protrusions, or gate burrs shall not exceed 0.15 mm per side.
4. This dimension does not include interlead flash. Interlead flash shall not exceed 0.25 mm per side.
5. Reference JEDEC registration MO-153.

# EXAMPLE BOARD LAYOUT

PW0024A

TSSOP - 1.2 mm max height

SMALL OUTLINE PACKAGE

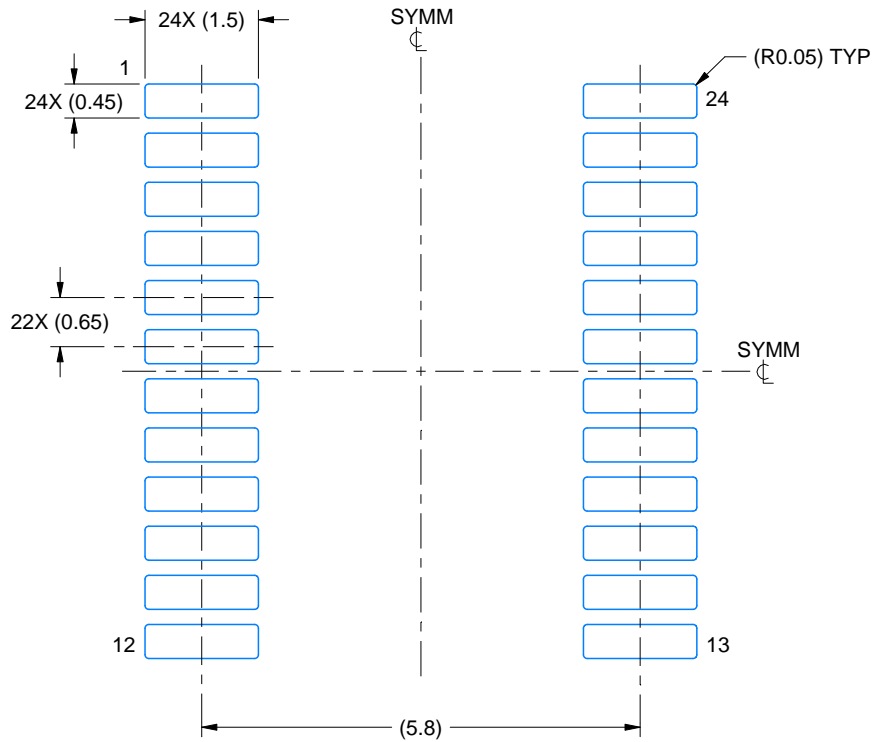

LAND PATTERN EXAMPLE  
EXPOSED METAL SHOWN  
SCALE: 10X



SOLDER MASK DETAILS

4220208/A 02/2017

NOTES: (continued)

- 6. Publication IPC-7351 may have alternate designs.
- 7. Solder mask tolerances between and around signal pads can vary based on board fabrication site.

# EXAMPLE STENCIL DESIGN

PW0024A

TSSOP - 1.2 mm max height

SMALL OUTLINE PACKAGE



NOTES: (continued)

8. Laser cutting apertures with trapezoidal walls and rounded corners may offer better paste release. IPC-7525 may have alternate design recommendations.
9. Board assembly site may have different recommendations for stencil design.

## IMPORTANT NOTICE AND DISCLAIMER

TI PROVIDES TECHNICAL AND RELIABILITY DATA (INCLUDING DATA SHEETS), DESIGN RESOURCES (INCLUDING REFERENCE DESIGNS), APPLICATION OR OTHER DESIGN ADVICE, WEB TOOLS, SAFETY INFORMATION, AND OTHER RESOURCES "AS IS" AND WITH ALL FAULTS, AND DISCLAIMS ALL WARRANTIES, EXPRESS AND IMPLIED, INCLUDING WITHOUT LIMITATION ANY IMPLIED WARRANTIES OF MERCHANTABILITY, FITNESS FOR A PARTICULAR PURPOSE OR NON-INFRINGEMENT OF THIRD PARTY INTELLECTUAL PROPERTY RIGHTS.

These resources are intended for skilled developers designing with TI products. You are solely responsible for (1) selecting the appropriate TI products for your application, (2) designing, validating and testing your application, and (3) ensuring your application meets applicable standards, and any other safety, security, regulatory or other requirements.

These resources are subject to change without notice. TI grants you permission to use these resources only for development of an application that uses the TI products described in the resource. Other reproduction and display of these resources is prohibited. No license is granted to any other TI intellectual property right or to any third party intellectual property right. TI disclaims responsibility for, and you will fully indemnify TI and its representatives against, any claims, damages, costs, losses, and liabilities arising out of your use of these resources.

TI's products are provided subject to [TI's Terms of Sale](#) or other applicable terms available either on [ti.com](https://www.ti.com) or provided in conjunction with such TI products. TI's provision of these resources does not expand or otherwise alter TI's applicable warranties or warranty disclaimers for TI products.

TI objects to and rejects any additional or different terms you may have proposed.

Mailing Address: Texas Instruments, Post Office Box 655303, Dallas, Texas 75265  
Copyright © 2024, Texas Instruments Incorporated