

# LM74703-Q1, LM74704-Q1 Automotive Ideal Diode Controller With External FET Health Indication

## 1 Features

- AEC-Q100 qualified with the following results
  - Device temperature grade 1:
    - 40°C to 125°C ambient operating temperature range
- 3.2-V to 65-V input range (3.9-V start up)
- 65-V reverse voltage rating
- Charge pump for external N-Channel MOSFET
- 20-mV ANODE to CATHODE pin forward voltage drop regulation
- Enable pin feature
- 1- $\mu$ A shutdown current (EN=Low)
- 80- $\mu$ A operating quiescent current (EN=High)
- 2.3-A peak gate turnoff current
- FETGOOD output to indicate external MOSFET health status
- Fast response to reverse current blocking:
  - < 0.75  $\mu$ s
- [EMI performance over extended frequency range \(150-kHz to 1-GHz\)](#)
- Meets automotive ISO7637 transient requirements with external TVS Diode
- 8-pin SOT-23 package 2.90 mm  $\times$  1.60 mm

## 2 Applications

- [Automotive ADAS systems - camera](#)
- [Automotive infotainment systems - digital cluster, head unit](#)
- [Body electronics and lighting](#)
- [Active ORing for redundant power](#)

## 3 Description

The LM74703-Q1, LM74704-Q1 is an automotive AEC Q100 qualified ideal diode controller which operates in conjunction with an external N-channel MOSFET as an ideal diode rectifier for low-loss reverse polarity protection with a 20-mV forward voltage drop. The wide supply input range of 3.2 V to 65 V allows control of popular DC bus voltages such as 12-V, 24-V, and 48-V automotive battery systems. The 3.2-V input voltage support is designed especially for severe cold crank requirements in automotive systems. The device can withstand and protect the loads from negative supply voltages down to –65 V.

The device controls the gate of the MOSFET to regulate the forward voltage drop at 20 mV. The regulation scheme enables graceful turn off of the MOSFET during a reverse current event and provides zero DC reverse current flow. Fast response (< 0.75  $\mu$ s) to reverse current blocking makes the device applicable for systems with output voltage holdup requirements during ISO7637 pulse testing as well as power fail and input micro-short conditions. LM74703-Q1, LM74704-Q1 has FETGOOD output to indicate external MOSFET drain to source short or open condition. The device features enable pin (EN). With the enable pin low, the controller is off and draws approximately 1- $\mu$ A of current.

### Device Information

PART NUMBER	PACKAGE <sup>(1)</sup>	PACKAGE SIZE <sup>(2)</sup>
LM74703-Q1	DDF (SOT-23, 8)	2.90 mm $\times$ 1.60 mm
LM74704-Q1		

(1) For more information, see [Section 12](#).

(2) The package size (length  $\times$  width) is a nominal value and includes pins, where applicable.

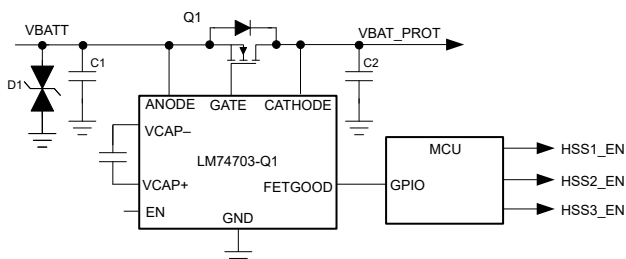

LM74703-Q1 Typical Application Schematic

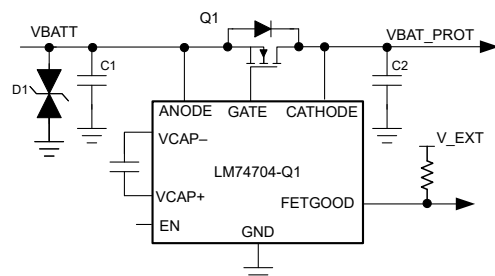

LM74704-Q1 Typical Application Schematic



## Table of Contents

<b>1 Features</b> .....	1	8.3 Feature Description.....	12
<b>2 Applications</b> .....	1	8.4 Device Functional Modes.....	15
<b>3 Description</b> .....	1	<b>9 Application and Implementation</b> .....	16
<b>4 Device Comparison Table</b> .....	3	9.1 Application Information.....	16
<b>5 Pin Configuration and Functions</b> .....	3	9.2 Typical Application.....	16
<b>6 Specifications</b> .....	4	9.3 Power Supply Recommendations.....	22
6.1 Absolute Maximum Ratings.....	4	9.4 Layout.....	22
6.2 ESD Ratings.....	4	<b>10 Device and Documentation Support</b> .....	23
6.3 Recommended Operating Conditions.....	4	10.1 Documentation Support.....	23
6.4 Thermal Information.....	5	10.2 Receiving Notification of Documentation Updates..	23
6.5 Electrical Characteristics.....	5	10.3 Support Resources.....	23
6.6 Switching Characteristics.....	6	10.4 Trademarks.....	23
6.7 Typical Characteristics.....	7	10.5 Electrostatic Discharge Caution.....	23
<b>7 Parameter Measurement Information</b> .....	10	10.6 Glossary.....	23
<b>8 Detailed Description</b> .....	11	<b>11 Revision History</b> .....	23
8.1 Overview.....	11	<b>12 Mechanical, Packaging, and Orderable Information</b> .....	23
8.2 Functional Block Diagram.....	11		

## 4 Device Comparison Table

	LM74703-Q1	LM74704-Q1
FETGOOD Output Type	Push-Pull Output	Open-Drain Output

## 5 Pin Configuration and Functions

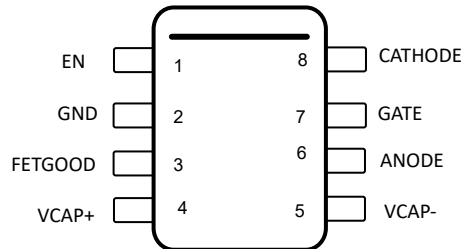

**Figure 5-1. DDF Package, 8-Pin SOT-23 (Top View)**

**Table 5-1. Pin Functions**

PIN		TYPE <sup>(1)</sup>	DESCRIPTION
NO.	NAME		
1	EN	I	Enable pin. Can be connected to ANODE for always ON operation.
2	GND	G	Ground pin.
3	FETGOOD	O	External MOSFET status indicator. LM74703-Q1 has push-pull while LM74704-Q1 has open drain FETGOOD output. When not used, FETGOOD pin can be left floating.
4	VCAP+	O	Charge pump output. Connect to external charge pump capacitor between VCAP+ and VCAP-.
5	VCAP-	I	Charge pump capacitor reference input.
6	ANODE	I	Anode of the diode and input power. Connect to the source of the external N-channel MOSFET.
7	GATE	O	Gate drive output. Connect to gate of the external N-channel MOSFET.
8	CATHODE	I	Cathode of the diode. Connect to the drain of the external N-channel MOSFET.

(1) I = Input, O = Output, G = GND

## 6 Specifications

### 6.1 Absolute Maximum Ratings

over operating free-air temperature range (unless otherwise noted)<sup>(1)</sup>

		MIN	MAX	UNIT
Input pins	ANODE, VCAP– to GND	–65	65	V
	EN to GND, $V_{(ANODE)} > 0$ V	–0.3	65	V
	EN to GND, $V_{(ANODE)} \leq 0$ V	$V_{(ANODE)}$	$(65 + V_{(ANODE)})$	V
Output pins	FETGOOD to GND	–0.3	80	V
	$I_{FETGOOD}$		1	mA
	GATE to ANODE	–0.3	15	V
	VCAP+ to VCAP–, ANODE	–0.3	15	V
Output to input pins	CATHODE to ANODE	–5	75	V
Operating junction temperature <sup>(2)</sup>		–40	150	°C
Storage temperature, $T_{stg}$		–40	150	°C

- Operation outside the Absolute Maximum Ratings may cause permanent device damage. Absolute Maximum Ratings do not imply functional operation of the device at these or any other conditions beyond those listed under Recommended Operating Conditions. If used outside the Recommended Operating Conditions but within the Absolute Maximum Ratings, the device may not be fully functional, and this may affect device reliability, functionality, performance, and shorten the device lifetime.
- High junction temperatures degrade operating lifetimes. Operating lifetime is de-rated for junction temperatures greater than 125°C.

### 6.2 ESD Ratings

			VALUE	UNIT	
$V_{(ESD)}$	Electrostatic discharge	Human body model (HBM), per AEC Q100-002 <sup>(1)</sup> HBM ESD classification level 2	±2000	V	
		Charged device model (CDM), per AEC Q100-011, CDM ESD classification level C4B	Corner pins (EN, VCAP+, VCAP– CATHODE)		±750
			Other pins		±500

- AEC Q100-002 indicates that HBM stressing shall be in accordance with the ANSI/ESDA/JEDEC JS-001 specification.

### 6.3 Recommended Operating Conditions

over operating free-air temperature range (unless otherwise noted)<sup>(1)</sup>

		MIN	NOM	MAX	UNIT
Input pins	ANODE, VCAP– to GND	–60		60	V
	CATHODE to GND			60	
	EN to GND	–60		60	
Input to output pins	ANODE to CATHODE	–70			V
External capacitance	ANODE	22			nF
	CATHODE to GND, VCAP+ to VCAP–	0.1			µF
External MOSFET max $V_{GS}$ rating	GATE to ANODE	15			V
$T_J$	Operating junction temperature range <sup>(2)</sup>	–40		150	°C

- Recommended Operating Conditions are conditions under which the device is intended to be functional. For specifications and test conditions, see [Section 6.5](#).
- High junction temperatures degrade operating lifetimes. Operating lifetime is de-rated for junction temperatures greater than 125°C.

## 6.4 Thermal Information

THERMAL METRIC <sup>(1)</sup>		LM74703-Q1, LM74704-Q1	UNIT
		DDF (SOT)	
		8 PINS	
R <sub>θJA</sub>	Junction-to-ambient thermal resistance	133.8	°C/W
R <sub>θJC(top)</sub>	Junction-to-case (top) thermal resistance	72.6	°C/W
R <sub>θJB</sub>	Junction-to-board thermal resistance	54.5	°C/W
Ψ <sub>JT</sub>	Junction-to-top characterization parameter	4.6	°C/W
Ψ <sub>JB</sub>	Junction-to-board characterization parameter	54.2	°C/W

(1) For more information about traditional and new thermal metrics, see the [Semiconductor and IC Package Thermal Metrics](#) application report.

## 6.5 Electrical Characteristics

T<sub>J</sub> = –40°C to 125°C; typical values at T<sub>J</sub> = 25°C, V<sub>(ANODE)</sub> = 12 V, C<sub>(VCAP+)</sub> = 0.1 μF, V<sub>(EN)</sub> = 3.3 V, over operating free-air temperature range (unless otherwise noted)

PARAMETER		TEST CONDITIONS	MIN	TYP	MAX	UNIT
<b>V<sub>ANODE</sub> SUPPLY VOLTAGE</b>						
V <sub>(ANODE)</sub>	Operating input voltage		4		60	V
V <sub>(ANODE POR)</sub>	VANODE POR rising threshold				3.9	V
	VANODE POR falling threshold		2.2	2.8	3.1	V
I <sub>(SHDN)</sub>	Shutdown supply current	V <sub>(EN)</sub> = 0 V		1	1.5	μA
I <sub>(Q)</sub>	Operating quiescent current			80	130	μA
<b>ENABLE INPUT</b>						
V <sub>(EN_IL)</sub>	Enable input low threshold		0.5	0.9	1.22	V
V <sub>(EN_IH)</sub>	Enable input high threshold		1.06	2	2.6	
I <sub>(EN)</sub>	Enable sink current	V <sub>(EN)</sub> = 12 V		3	5	μA
<b>FETGOOD</b>						
FETGOOD High	FETGOOD voltage for logic high	VCAP > VCAP_UVLO, V <sub>ANODE</sub> – V <sub>CATHODE</sub> < 200 mV, LM74703-Q1	4.45	5.2	6	V
R <sub>FETGOOD(pullup)</sub>	FETGOOD pullup resistor	VCAP > VCAP_UVLO, V <sub>ANODE</sub> – V <sub>CATHODE</sub> < 200 mV, LM74703-Q1		50		kΩ
R <sub>FETGOOD(pulldown)</sub>	FETGOOD pulldown resistor	VCAP < VCAP_UVLO or V <sub>ANODE</sub> – V <sub>CATHODE</sub> > 200 mV, LM74703-Q1		50		kΩ
R <sub>FETGOOD(pulldown)</sub>	FETGOOD pulldown resistor	VCAP < VCAP_UVLO or V <sub>ANODE</sub> – V <sub>CATHODE</sub> > 200 mV, LM74704-Q1		1	1.3	kΩ
FETGOOD Comparator	V <sub>AC</sub> comparator rising threshold for FETGOOD going low		180	200	230	mV
FETGOOD Comparator	V <sub>AC</sub> comparator falling threshold for FETGOOD going high		160	185	215	mV
FETGOOD Comparator hysteresis				15		mV
<b>V<sub>ANODE</sub> to V<sub>CATHODE</sub></b>						
V <sub>(AC_REG)</sub>	Regulated forward V <sub>(AC)</sub> threshold		13	20	29	mV
V <sub>(AC_FC)</sub>	V <sub>(AC)</sub> threshold for full conduction mode		34	50	57	mV
V <sub>(AC_REV)</sub>	V <sub>(AC)</sub> threshold for reverse current blocking		–17	–11	–2	mV
<b>GATE DRIVE</b>						

**LM74703-Q1, LM74704-Q1**

SNOSDF7A – MAY 2023 – REVISED DECEMBER 2023

 $T_J = -40^{\circ}\text{C}$  to  $125^{\circ}\text{C}$ ; typical values at  $T_J = 25^{\circ}\text{C}$ ,  $V_{(\text{ANODE})} = 12\text{ V}$ ,  $C_{(\text{VCAP}+)} = 0.1\ \mu\text{F}$ ,  $V_{(\text{EN})} = 3.3\text{ V}$ , over operating free-air temperature range (unless otherwise noted)

PARAMETER		TEST CONDITIONS	MIN	TYP	MAX	UNIT
$I_{(\text{GATE})}$	Peak source current	$V_{(\text{ANODE})} - V_{(\text{CATHODE})} = 100\text{ mV}$ , $V_{(\text{GATE})} - V_{(\text{ANODE})} = 200\text{ mV}$	3	11		mA
	Peak sink current	$V_{(\text{ANODE})} - V_{(\text{CATHODE})} = -20\text{ mV}$ , $V_{(\text{GATE})} - V_{(\text{ANODE})} = 5\text{ V}$		2370		mA
	Regulation max sink current	$V_{(\text{ANODE})} - V_{(\text{CATHODE})} = 0\text{ V}$ , $V_{(\text{GATE})} - V_{(\text{ANODE})} = 200\text{ mV}$	6	26		$\mu\text{A}$
$R_{\text{DS(ON)}}$	Discharge switch $R_{\text{DS(ON)}}$	$V_{(\text{ANODE})} - V_{(\text{CATHODE})} = -100\text{ mV}$ , $V_{(\text{GATE})} - V_{(\text{ANODE})} = 100\text{ mV}$	0.4	1	2	$\Omega$
<b>CHARGE PUMP</b>						
$I_{(\text{VCAP})}$	Charge pump source current (charge pump on)	$V_{(\text{VCAP}+)} - V_{(\text{VCAP}-)} = 7\text{ V}$	162	300	600	$\mu\text{A}$
	Charge pump sink current (charge pump off)	$V_{(\text{VCAP}+)} - V_{(\text{VCAP}-)} = 14\text{ V}$		5	10	$\mu\text{A}$
$V_{(\text{VCAP}+)} - V_{(\text{VCAP}-)}$	Charge pump voltage at $V_{(\text{ANODE})} = 3.2\text{ V}$	$I_{(\text{VCAP})} \leq 30\ \mu\text{A}$	8			V
	Charge pump turn on voltage		10.8	12.1	12.9	V
	Charge pump turn off voltage		11.6	13	13.9	V
	Charge pump enable comparator hysteresis		0.54	0.9	1.36	V
$V_{(\text{VCAP UVLO})}$	$V_{(\text{VCAP})} - V_{(\text{ANODE})}$ UV release at rising edge	$V_{(\text{ANODE})} - V_{(\text{CATHODE})} = 100\text{ mV}$	5.8	6.6	7.7	V
	$V_{(\text{VCAP})} - V_{(\text{ANODE})}$ UV threshold at falling edge	$V_{(\text{ANODE})} - V_{(\text{CATHODE})} = 100\text{ mV}$	5.11	5.68	6	V
<b>CATHODE</b>						
$I_{(\text{CATHODE})}$	CATHODE sink current	$V_{(\text{ANODE})} = 12\text{ V}$ , $V_{(\text{ANODE})} - V_{(\text{CATHODE})} = 100\text{ mV}$		1.7	2	$\mu\text{A}$
		$V_{(\text{ANODE})} - V_{(\text{CATHODE})} = -100\text{ mV}$		1.2	2.2	$\mu\text{A}$
		$V_{(\text{ANODE})} = -12\text{ V}$ , $V_{(\text{CATHODE})} = 12\text{ V}$		1.25	2.06	$\mu\text{A}$

## 6.6 Switching Characteristics

 $T_J = -40^{\circ}\text{C}$  to  $125^{\circ}\text{C}$ ; typical values at  $T_J = 25^{\circ}\text{C}$ ,  $V_{(\text{ANODE})} = 12\text{ V}$ ,  $C_{(\text{VCAP}+)} = 0.1\ \mu\text{F}$ ,  $V_{(\text{EN})} = 3.3\text{ V}$ , over operating free-air temperature range (unless otherwise noted)

PARAMETER		TEST CONDITIONS	MIN	TYP	MAX	UNIT
$t_{\text{ENTDLY}}$	Enable (low to high) to gate turn on delay	$V_{(\text{VCAP})} > V_{(\text{VCAP UVLOR})}$		75	115	$\mu\text{s}$
$t_{\text{Reverse delay}}$	Reverse voltage detection to gate turn off delay	$V_{(\text{ANODE})} - V_{(\text{CATHODE})} = 100\text{ mV}$ to $-100\text{ mV}$		0.5	0.75	$\mu\text{s}$
$t_{\text{Forward recovery}}$	Forward voltage detection to gate turn on delay	$V_{(\text{ANODE})} - V_{(\text{CATHODE})} = -100\text{ mV}$ to $700\text{ mV}$		1.4	2.6	$\mu\text{s}$
$t_{\text{FETGOOD\_ASSERT(DLY)}}$	FETGOOD assert delay	$V_{\text{ANODE}} - V_{\text{CATHODE}} > 200\text{ mV}$ or $\text{VCAP} < \text{VCAP\_UVLO}$ to FETGOOD $\downarrow$		40	60	$\mu\text{s}$
$t_{\text{FETGOOD\_DEASSERT(DLY)}}$	FETGOOD de-assert delay	$V_{\text{ANODE}} - V_{\text{CATHODE}} < 200\text{ mV}$ and $\text{VCAP} > \text{VCAP\_UVLO}$ to FETGOOD $\uparrow$		5		$\mu\text{s}$

### 6.7 Typical Characteristics

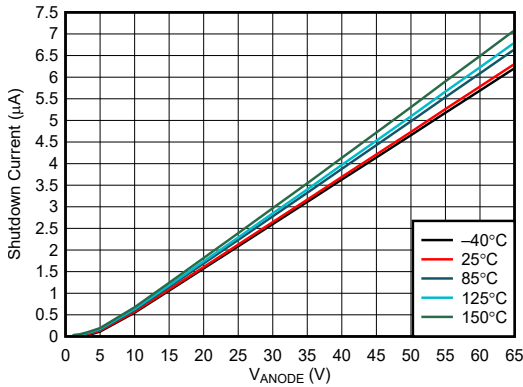

Figure 6-1. Shutdown Supply Current vs Supply Voltage

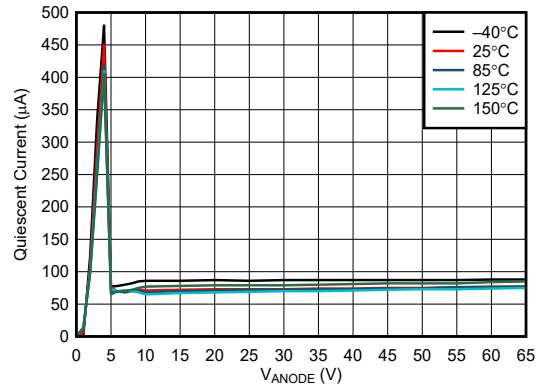

Figure 6-2. Operating Quiescent Current vs Supply Voltage

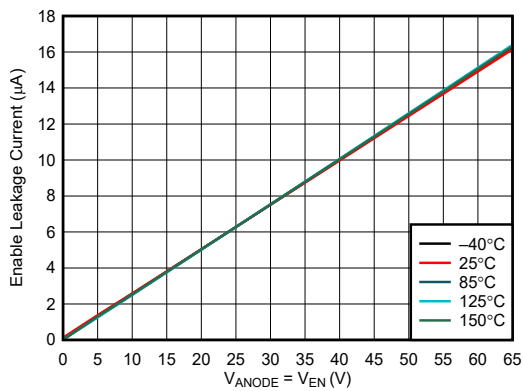

Figure 6-3. Enable Sink Current vs Supply Voltage

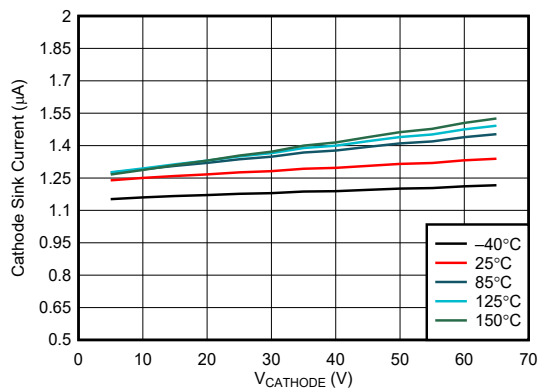

Figure 6-4. CATHODE Sink Current vs Supply Voltage

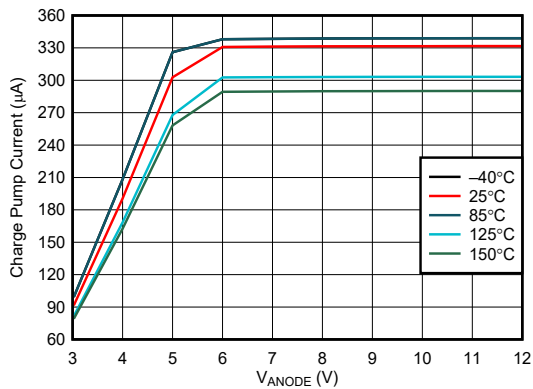

Figure 6-5. Charge Pump Current vs Supply Voltage at VCAP = 6 V

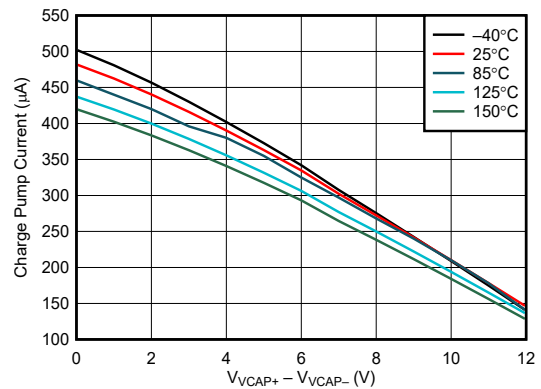

Figure 6-6. Charge Pump V-I Characteristics at ANODE >= 12 V

### 6.7 Typical Characteristics (continued)

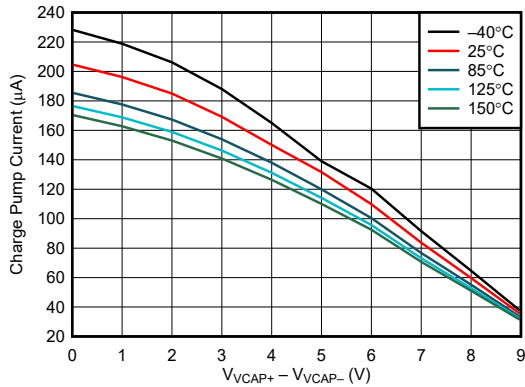

Figure 6-7. Charge Pump V-I Characteristics at ANODE = 3.2 V

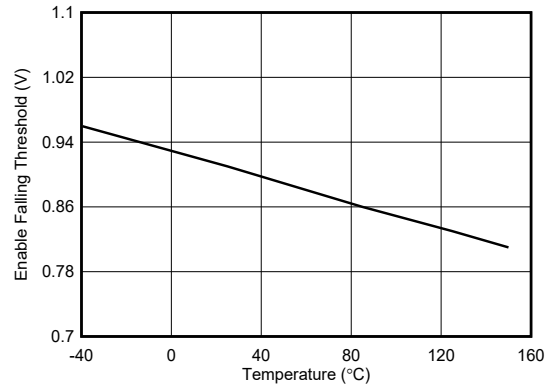

Figure 6-8. Enable Falling Threshold vs Temperature

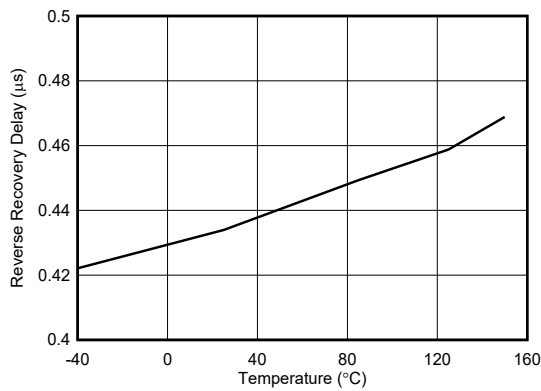

Figure 6-9. Reverse Current Blocking Delay vs Temperature

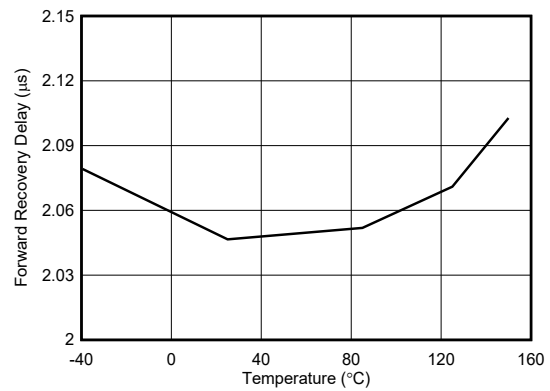

Figure 6-10. Forward Recovery Delay vs Temperature

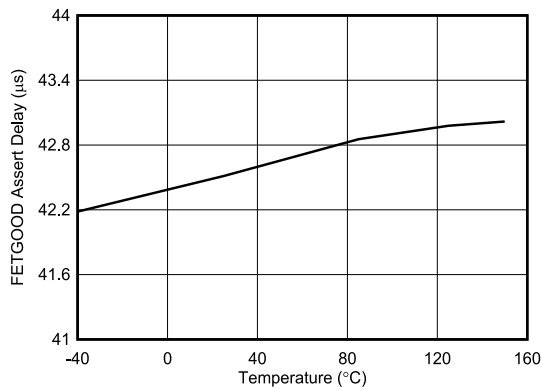

Figure 6-11. FETGOOD Assert Delay

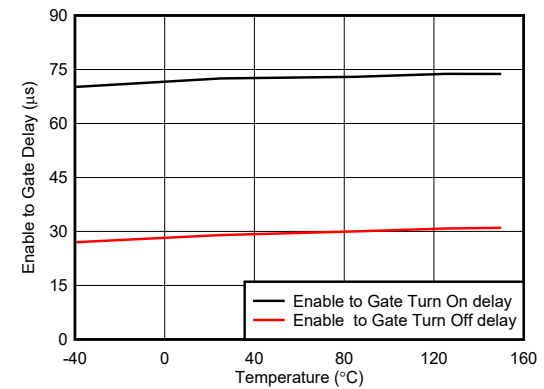
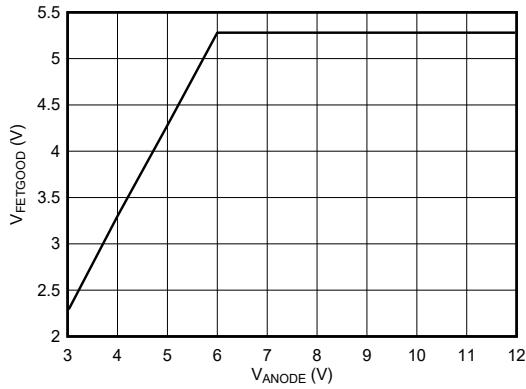

Figure 6-12. Enable to Gate Delay vs Temperature



### 6.7 Typical Characteristics (continued)



**Figure 6-13. LM74703-Q1 FETGOOD Output Level (Push-Pull Variant)**

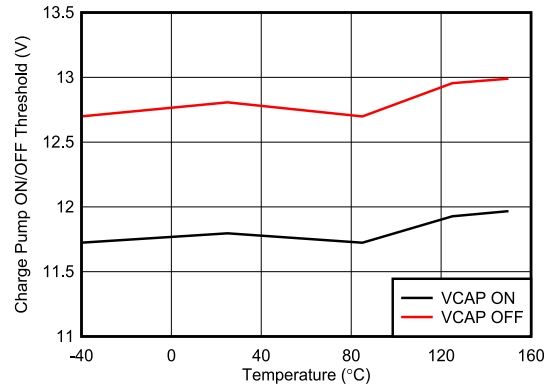

**Figure 6-14. Charge Pump ON/OFF Threshold vs Temperature**

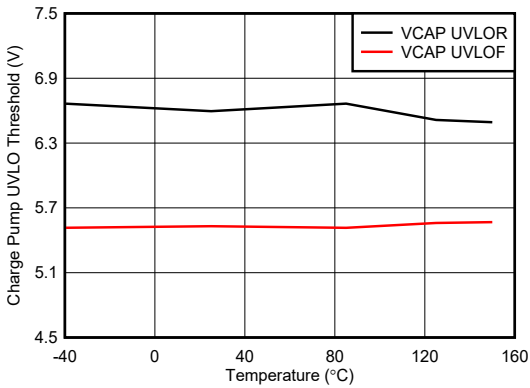

**Figure 6-15. Charge Pump UVLO Threshold vs Temperature**

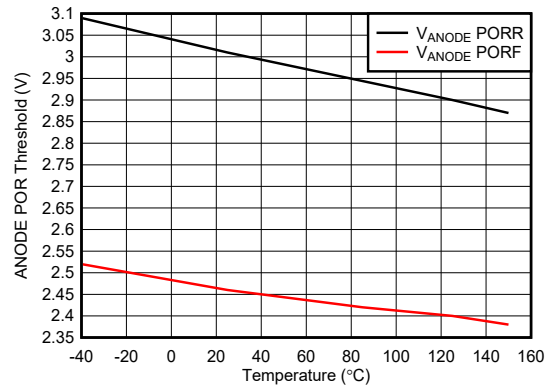

**Figure 6-16. ANODE POR Threshold vs Temperature**

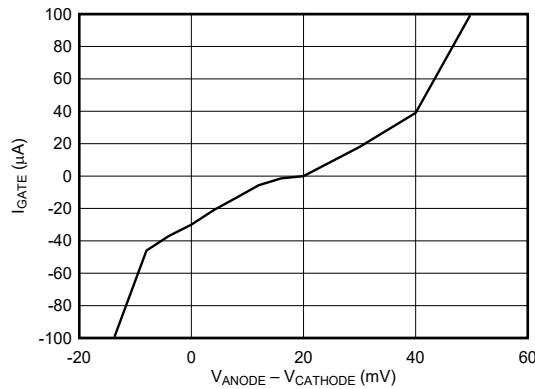

**Figure 6-17. Gate Current vs Forward Voltage Drop**

## 7 Parameter Measurement Information

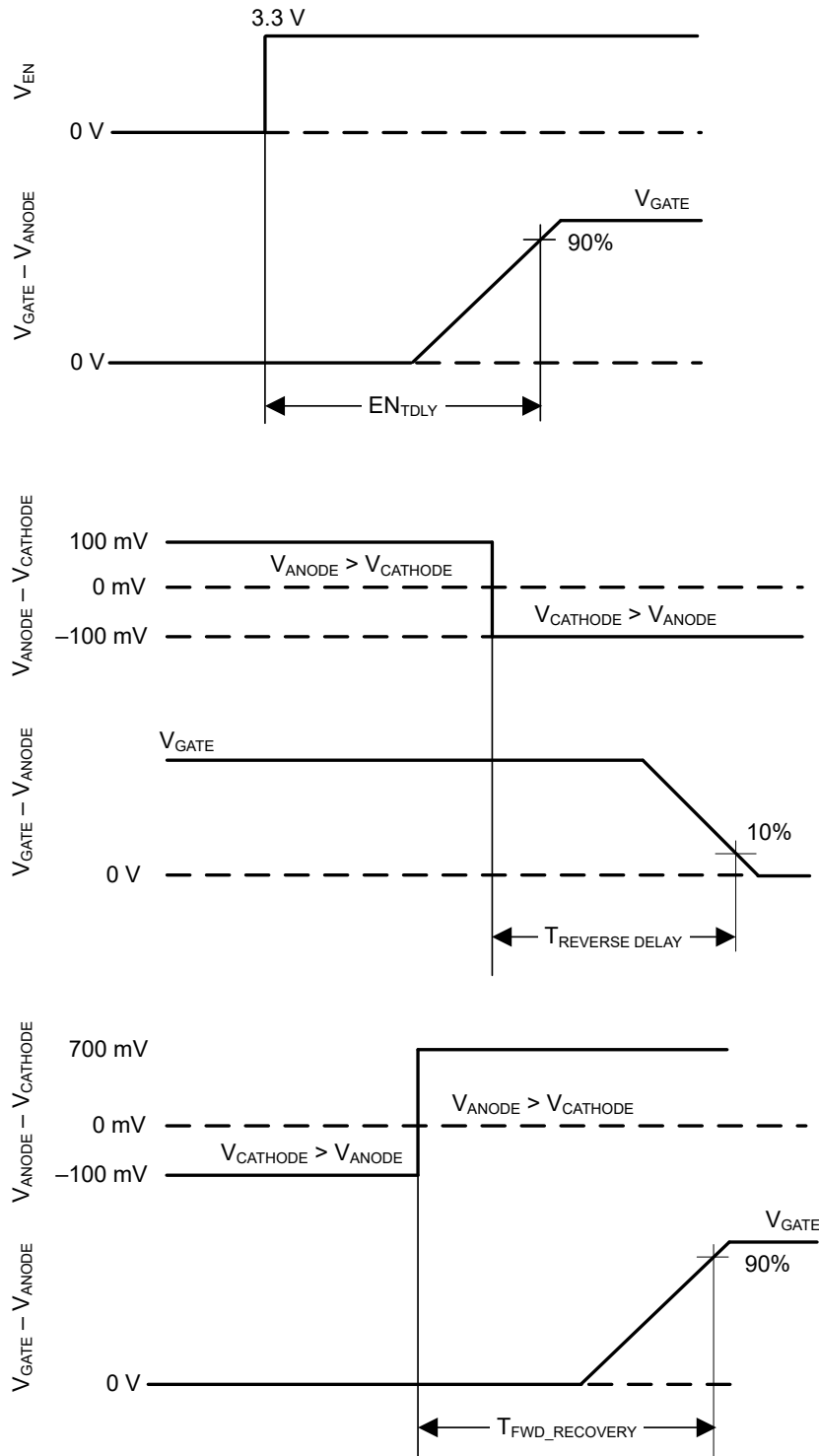

Figure 7-1. Timing Waveforms

## 8 Detailed Description

### 8.1 Overview

The LM74703-Q1 and LM74704-Q1 **ideal diode controllers** have all the features necessary to implement an efficient and fast reverse polarity protection circuit. The devices can be used in an ORing configuration while minimizing the number of external components. This easy-to-use ideal diode controller is paired with an external N-channel MOSFET to replace other reverse polarity schemes like a P-channel MOSFET or a Schottky diode. An internal charge pump drives the external N-Channel MOSFET to a maximum gate-to-source drive voltage of approximately 12 V. The voltage drop across the MOSFET is continuously monitored between the ANODE and CATHODE pins, and the GATE to ANODE pin voltages are adjusted as needed to regulate the forward voltage drop at 20 mV. This closed-loop regulation scheme enables graceful turn off of the MOSFET during a reverse current event and provides zero DC reverse current flow. A fast reverse current condition is detected when the voltage across the ANODE and CATHODE pins reduces below  $-11$  mV. This behavior connects the GATE pin internally to the ANODE pin, turning off the external N-channel MOSFET, and using the body diode to block any of the reverse current. An enable pin, EN, is available to place the LM74703-Q1 in shutdown mode, disabling the N-Channel MOSFET and minimizing the quiescent current.

LM74703-Q1 and LM74704-Q1 offer an external FET health monitoring feature with the FETGOOD pin. The device monitors for external FET drain-to-source short or open condition during power-up and pulls the FETGOOD pin low in case the external FET fault condition is diagnosed.

For automotive applications like automotive lighting, camera modules that are typically exterior facing require low conducted and radiated emissions in the frequency band ranging up to few Gigahertz (GHz). LM74703-Q1 and LM74704-Q1 offer **low emissions in high-frequency band**, making these devices a good candidate for applications where emissions in high-frequency band are a key consideration.

### 8.2 Functional Block Diagram

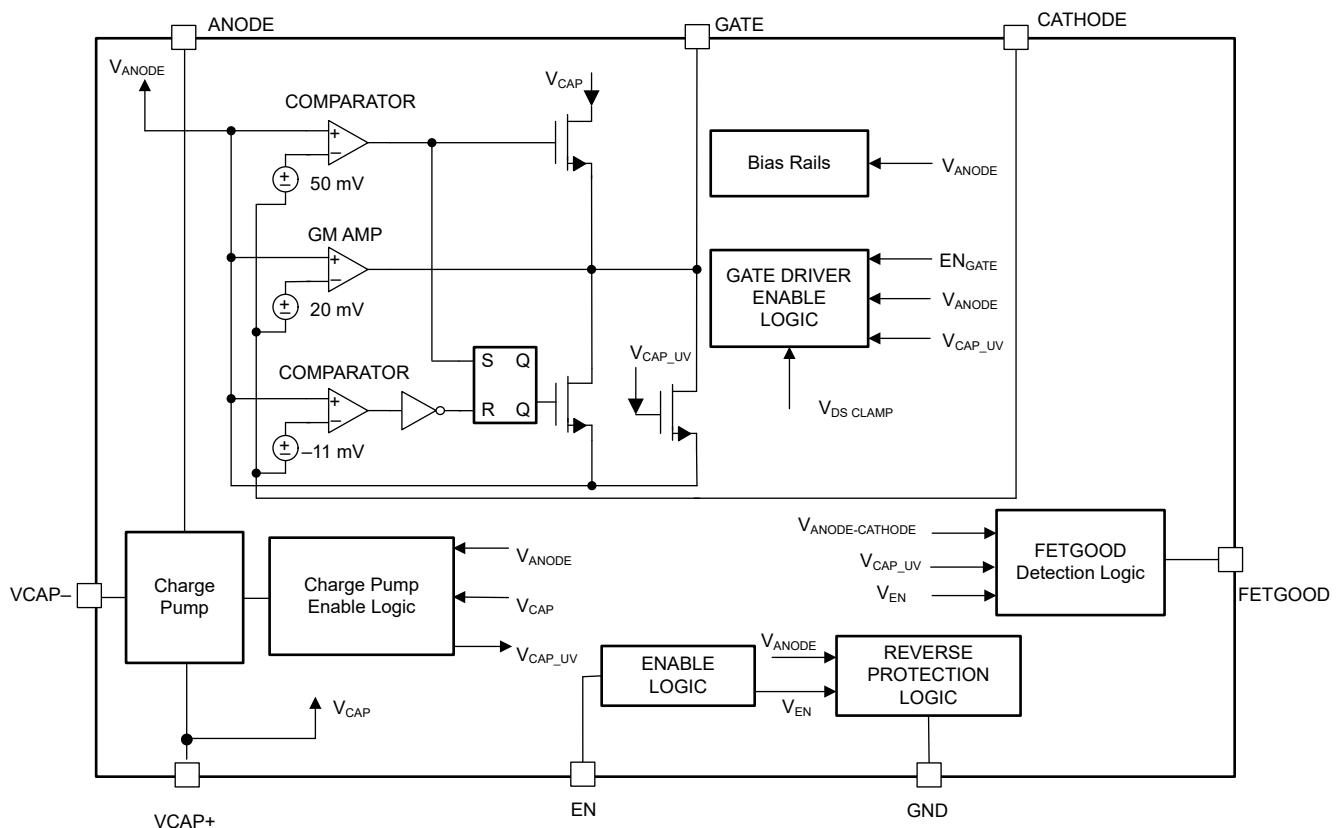

## 8.3 Feature Description

### 8.3.1 Input Voltage

The ANODE pin is used to power the internal circuitry of the LM74703-Q1, LM74704-Q1 typically drawing 80  $\mu\text{A}$  when enabled and 1  $\mu\text{A}$  when disabled. If the ANODE pin voltage is greater than the POR rising threshold, then LM74703-Q1 operates in either shutdown mode or conduction mode in accordance with the EN pin voltage. The voltage from ANODE to GND is designed to vary from  $-65\text{ V}$  to  $65\text{ V}$ , allowing the device to withstand negative voltage transients.

### 8.3.2 Charge Pump

The charge pump supplies the voltage necessary to drive the external N-channel MOSFET. An external charge pump capacitor is placed between VCAP+ and VCAP– pins to provide energy to turn on the external MOSFET. For the charge pump to supply current to the external capacitor, the EN pin voltage must be above the specified input high threshold,  $V_{(\text{EN\_IH})}$ . When enabled, the charge pump sources a charging current of 300- $\mu\text{A}$  typical. If EN pins is pulled low, then the charge pump remains disabled. To make sure that the external MOSFET can be driven above the specified threshold voltage of the MOSFET, the VCAP+ to VCAP–voltage must be above the undervoltage lockout threshold, which is typically 6.6 V, before the internal gate driver is enabled. Use [Equation 1](#) to calculate the initial gate driver enable delay.

$$T_{\text{DRV\_EN}} = 75\ \mu\text{s} + C_{\text{VCAP}} \times \frac{V_{\text{VCAP\_UVLOR}}}{300\ \mu\text{A}} \quad (1)$$

where

- $C_{(\text{VCAP})}$  is the charge pump capacitance connected across ANODE and VCAP pins
- $V_{(\text{VCAP\_UVLOR})} = 6.6\text{ V}$  (typical)

To remove any chatter on the gate drive, approximately 900 mV of hysteresis is added to the VCAP undervoltage lockout. The charge pump remains enabled until the VCAP+ to VCAP–voltage reaches the typical 13 V, typically, at which point the charge pump is disabled, decreasing the current drawn on the ANODE pin. The charge pump remains disabled until the VCAP+ to VCAP– voltage is below the typical 12.1 V, enabling the charge pump. The voltage between VCAP+ to VCAP– continue to charge and discharge between 12.1 V and 13 V as shown in [Figure 8-1](#). By enabling and disabling the charge pump, the operating quiescent current of the LM74703-Q1 is reduced. When the charge pump is disabled, the charge pump typically sinks 5  $\mu\text{A}$ .

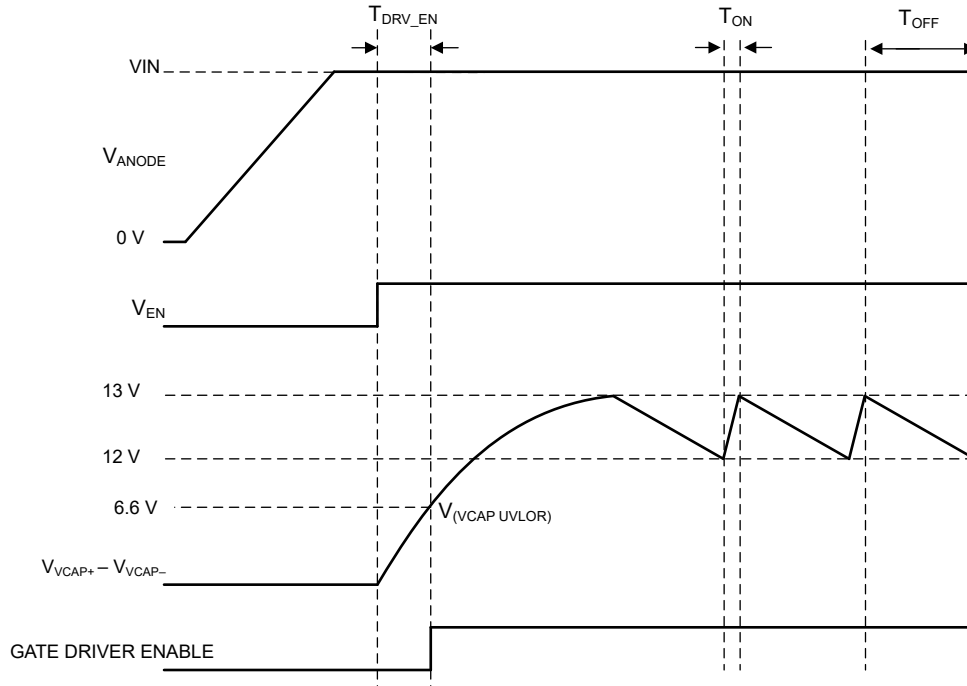

Figure 8-1. Charge Pump Operation

### 8.3.3 Gate Driver

The gate driver is used to control the external N-Channel MOSFET by setting the GATE to ANODE voltage to the corresponding mode of operation. According to the ANODE to CATHODE voltage, there are three defined modes of operation that the gate driver operates under: forward regulation, full conduction mode, and reverse current protection. Forward regulation mode, full conduction mode, and reverse current protection mode are described in more detail in the [Regulated conduction Mode](#), [Full Conduction Mode](#), and [Reverse Current Production Mode](#) sections. Figure 8-2 depicts how the modes of operation vary according to the ANODE to CATHODE voltage of the LM74703-Q1. The threshold between forward regulation mode and conduction mode is when the ANODE to CATHODE voltage is 50 mV. The threshold between forward regulation mode and reverse current protection mode is when the ANODE to CATHODE pin voltages are -11 mV.

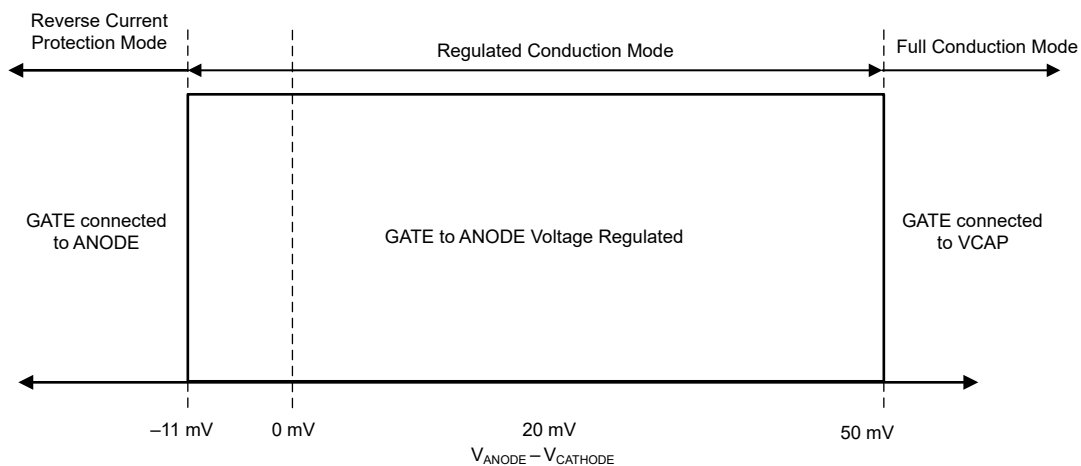

Figure 8-2. Gate Driver Mode Transitions

Before the gate driver is enabled, the following three conditions must be achieved:

- The EN pin voltage must be greater than the specified input high voltage.
- The VCAP+ to VCAP– voltage must be greater than the undervoltage lockout voltage.
- The ANODE voltage must be greater than  $V_{\text{ANODE}}$  POR rising threshold.

If the above conditions are not achieved, then the GATE pin is internally connected to the ANODE pin, assuring that the external MOSFET is disabled. Once these conditions are achieved, the gate driver operates in the correct mode depending on the ANODE to CATHODE pin voltage.

### 8.3.4 Enable

The LM74703-Q1 has an enable pin, EN. The enable pin allows for the gate driver to be either enabled or disabled by an external signal. If the EN pin voltage is greater than the rising threshold, the gate driver and charge pump operates as described in [Gate Driver](#) and [Charge Pump](#) sections. If the enable pin voltage is less than the input low threshold, the charge pump and gate driver are disabled placing the LM74703-Q1 in shutdown mode. The EN pin can withstand a voltage as large as 65 V and as low as –65 V. This range allows for the EN pin to be connected directly to the ANODE pin if enable functionality is not needed. In conditions where EN is left floating, the internal sink current of 3  $\mu\text{A}$  pulls the EN pin low and disables the device.

### 8.3.5 FET Status Indication (FETGOOD)

LM74703-Q1 and LM74704-Q1 have FETGOOD pin, which can be used to detect external MOSFET health, such as in cases where a MOSFET is short or open. The device monitors the external MOSFET source to drain voltage drop to decide MOSFET status as either MOSFET open or MOSFET short condition. The FETGOOD pin is pulled low whenever a MOSFET fault condition is detected.

MOSFET source to drain short detection is performed and status is indicated at each start-up event (ANODE ramp-up or EN pin going from low to high). For MOSFET source to drain short detection to work correctly, the device ANODE pin voltage must be 200 mV higher than the CATHODE pin voltage before performing external MOSFET short diagnosis.

For ideal diode configuration when the controller is off, output loads are always powered through the body diode of the external MOSFET. Detecting if the external MOSFET is completely turned-on or not before turning on downstream loads is important for avoiding large currents flowing through the body diode of MOSFET, which can potentially damage the MOSFET. This condition can arise due to gate voltage not getting applied to the MOSFET gate pin under specific fault condition, such as a MOSFET gate pin open due to a PCB manufacturing defect. LM74703-Q1 and LM74704-Q1 monitor external MOSFET source-to-drain drops and pulls the FETGOOD pin low if this drop is higher than 200 mV, even when the gate voltage is applied to the MOSFET. This behavior helps the system to monitor the MOSFET off condition during start-up (even when ideal diode controller is enabled) and indicate the MOSFET open fault using FETGOOD pin so that a decision on system level can be taken to turn off downstream loads to avoid large load current flowing through the body diode of the MOSFET. MOSFET open detection is available during device start-up as well as during normal operation.

The FETGOOD pin is also pulled low if the charge pump voltage is lower than the charge pump UVLO threshold of 6.6 V indicating gate drive voltage is not enough to fully enhance the MOSFET.

LM74703-Q1 has a push-pull FETGOOD output to support systems where there are not external pullups or bias voltages available when the system starts-up.

LM74704-Q1 has an open-drain FETGOOD output. The FETGOOD pin must be pulled to an external bias voltage through a pullup resistor. The external pullup resistor must be selected such that current through the FETGOOD pulldown switch is less than 1-mA to stay within the recommended operating conditions.

When not used, the FETGOOD pin must be left floating.

## 8.4 Device Functional Modes

### 8.4.1 Shutdown Mode

The LM74703-Q1 enters shutdown mode when the EN pin voltage is below the specified input low threshold  $V_{(EN\_IL)}$ . Both the gate driver and the charge pump are disabled in shutdown mode. During shutdown mode the LM74703-Q1 enters low  $I_Q$  operation with the ANODE pin only sinking 1  $\mu$ A. When the LM74703-Q1 is in shutdown mode, forward current flow through the external MOSFET is not interrupted but is conducted through the body diode of the MOSFET.

### 8.4.2 Conduction Mode

Conduction mode occurs when the gate driver is enabled. There are three regions of operating during conduction mode based on the ANODE to CATHODE pin voltage of the LM74703-Q1. Each of the three modes is described in the [Regulated Conduction Mode](#), [Full Conduction Mode](#) and [Reverse Current Protection Mode](#) sections.

#### 8.4.2.1 Regulated Conduction Mode

For the LM74703-Q1 to operate in regulated conduction mode, the gate driver must be enabled as described in the [Gate Driver](#) section and the current from source to drain of the external MOSFET must be within range to result in an ANODE to CATHODE pin voltage drop of  $-11$  mV to 50 mV. During forward regulation mode, the ANODE to CATHODE pin voltages are regulated to 20 mV by adjusting the GATE to ANODE pin voltage. This closed loop regulation scheme provides graceful turn off of the MOSFET at very light loads and provides zero DC reverse current flow.

#### 8.4.2.2 Full Conduction Mode

For the LM74703-Q1 to operate in full conduction mode the gate driver must be enabled as described in the [Gate Driver](#) section and the current from source to drain of the external MOSFET must be large enough to result in an ANODE to CATHODE pin voltage drop of greater than 50-mV typical. If these conditions are achieved, the GATE pin is internally connected to the VCAP pin resulting in the GATE to ANODE pin voltages being approximately the same as the VCAP to ANODE voltage. By connecting VCAP to GATE pin the  $R_{DS(ON)}$  of the external MOSFET is minimized reducing the power loss of the external MOSFET when forward currents are large.

#### 8.4.2.3 Reverse Current Protection Mode

For the LM74703-Q1 to operate in reverse current protection mode, the gate driver must be enabled as described in the [Gate Driver](#) section and the current of the external MOSFET must be flowing from the drain to the source. When the ANODE to CATHODE pin voltage is typically less than  $-11$  mV, reverse current protection mode is entered and the GATE pin is internally connected to the ANODE pin. The connection of the GATE to ANODE pin disables the external MOSFET. The body diode of the MOSFET blocks any reverse current from flowing from the drain to source.

## 9 Application and Implementation

### Note

Information in the following applications sections is not part of the TI component specification, and TI does not warrant its accuracy or completeness. TI's customers are responsible for determining suitability of components for their purposes, as well as validating and testing their design implementation to confirm system functionality.

### 9.1 Application Information

The LM74703-Q1, LM74704-Q1 is used with an N-Channel MOSFET controller in a typical reverse polarity protection application. The schematic for the 12-V battery protection application is shown in [Figure 9-1](#) where the LM74703-Q1, LM74704-Q1 is used in series with a battery to drive the MOSFET Q1. The external TVS diode is not required for the LM74703-Q1 and LM74704-Q1 to operate, but the TVS diode is used to clamp the positive and negative voltage surges. The output capacitor  $C_{OUT}$  is recommended to protect the immediate output voltage collapse as a result of line disturbance.

### 9.2 Typical Application

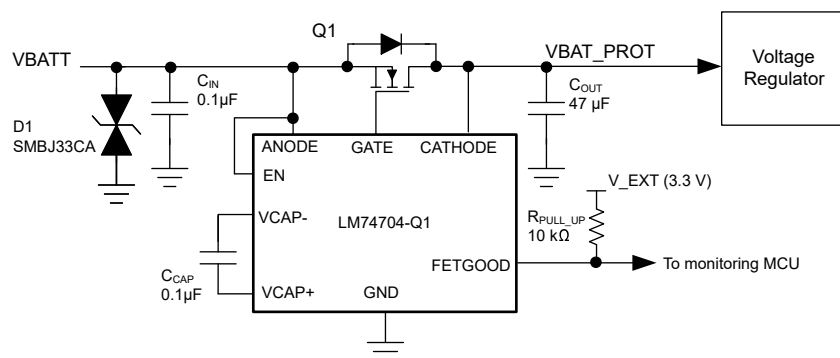

**Figure 9-1. Typical Application Circuit**

#### 9.2.1 Design Requirements

A design example, with system design parameters listed in [Table 9-1](#) is presented.

**Table 9-1. Design Parameters**

DESIGN PARAMETER	EXAMPLE VALUE
Input voltage range	12-V Battery, 12-V Nominal with 3.2-V Cold Crank and 35-V Load Dump
Output voltage	3.2 V during Cold Crank to 35-V Load Dump
Output current range	3-A Nominal, 6-A Maximum
Output capacitance	1- $\mu$ F Minimum, optional 47- $\mu$ F Hold Up Capacitance
Automotive EMC Compliance	ISO 7637-2 and ISO 16750-2

#### 9.2.2 Detailed Design Procedure

##### 9.2.2.1 Design Considerations

- Input operating voltage range, including cold crank and load dump conditions
- Nominal load current and maximum load current



### 9.2.2.2 MOSFET Selection

Important MOSFET electrical parameters are the maximum continuous drain current  $I_D$ , the maximum drain-to-source voltage  $V_{DS(MAX)}$ , the maximum source current through body diode, and the drain-to-source On resistance  $R_{DS(ON)}$ .

The maximum continuous drain current,  $I_D$ , rating must exceed the maximum continuous load current. The maximum drain-to-source voltage,  $V_{DS(MAX)}$ , must be high enough to withstand the highest differential voltage seen in the application, including any anticipated fault conditions. Using MOSFETs with voltage rating up to 60-V maximum with the LM74704-Q1 is recommended because the ANODE and CATHODE pin maximum voltage rating is 65 V. The maximum  $V_{GS}$  that the LM74704-Q1 can drive is 13 V, so a MOSFET with 15-V minimum  $V_{GS}$  must be selected. If a MOSFET with < 15-V  $V_{GS}$  rating is selected, a Zener diode can be used to clamp  $V_{GS}$  to safe level. During startup, inrush current flows through the body diode to charge the bulk hold-up capacitors at the output. The maximum source current through the body diode must be higher than the inrush current that can be seen in the application.

To reduce the MOSFET conduction losses, the lowest possible  $R_{DS(ON)}$  is preferred, but selecting a MOSFET based on low  $R_{DS(ON)}$  is not always beneficial. Higher  $R_{DS(ON)}$  provides increased voltage information to the reverse comparator of the LM74704-Q1 at a lower reverse current. Reverse current detection is better with increased  $R_{DS(ON)}$ . Operating the MOSFET in regulated conduction mode during nominal load conditions is recommended as well as selecting  $R_{DS(ON)}$  such that at nominal operating current the forward voltage drop  $V_{DS}$  is close to 20-mV regulation point and not more than 50 mV.

As a guideline, choose  $(20 \text{ mV} / I_{Load(Nominal)}) \leq R_{DS(ON)} \leq (50 \text{ mV} / I_{Load(Nominal)})$ .

MOSFET manufacturers typically specify  $R_{DS(ON)}$  at 4.5-V  $V_{GS}$  and 10-V  $V_{GS}$ .  $R_{DS(ON)}$  increases drastically below 4.5-V  $V_{GS}$  and  $R_{DS(ON)}$  is highest when  $V_{GS}$  is close to MOSFET  $V_{th}$ . For stable regulation at light load conditions, operating the MOSFET close to 4.5-V  $V_{GS}$  is recommended, which is much higher than the MOSFET gate threshold voltage. Choosing a MOSFET with a typical gate threshold voltage  $V_{th}$  of 2 V to 2.5 V is recommended. Choosing a lower  $V_{th}$  MOSFET also reduces the turn ON time.

Based on the design requirements, the preferred MOSFET ratings are:

- 60-V  $V_{DS(MAX)}$  and  $\pm 20$ -V  $V_{GS(MAX)}$
- $R_{DS(ON)}$  at 3-A nominal current:  $(20 \text{ mV} / 3 \text{ A}) \leq R_{DS(ON)} \leq (50 \text{ mV} / 3 \text{ A}) = 6.67 \text{ m}\Omega \leq R_{DS(ON)} \leq 16.67 \text{ m}\Omega$
- MOSFET gate threshold voltage  $V_{th}$ : 2 V typical

Thermal resistance of the MOSFET must be considered against the expected maximum power dissipation in the MOSFET to make sure that the junction temperature ( $T_J$ ) is well controlled.

### 9.2.2.3 Charge Pump VCAP, Input and Output Capacitance

Minimum required capacitance for charge pump VCAP, input and output capacitance are:

- VCAP: Minimum 0.1  $\mu\text{F}$  is required; recommended value of VCAP ( $\mu\text{F}$ )  $\geq 10 \times C_{ISS(MOSFET)}$ ( $\mu\text{F}$ )
- $C_{IN}$ : minimum 22 nF of input capacitance
- $C_{OUT}$ : minimum 100 nF of output capacitance

### 9.2.2.4 Selection of TVS Diodes for 12-V Battery Protection Applications

TVS diodes are used in automotive systems for protection against transients. In the 12-V battery protection application circuit shown in [Figure 9-2](#), a bi-directional TVS diode is used to protect from positive and negative transient voltages that occur during normal operation of the car. These transient voltage levels and pulses are specified in ISO 7637-2 and ISO 16750-2 standards.

Two important specifications are breakdown voltage and clamping voltage of the TVS. Breakdown voltage is the voltage at which the TVS diode goes into avalanche, similar to a Zener diode, and is specified at a low current value (typical 1 mA). The breakdown voltage must be higher than worst-case steady state voltages seen in the system. The breakdown voltage of the TVS+ must be higher than 24-V jump start voltage and 35-V suppressed load dump voltage and less than the maximum ratings of LM74703-Q1 and LM74704-Q1 (65 V). The breakdown

voltage of TVS- must be beyond the maximum reverse battery voltage  $-16\text{ V}$ , so that the TVS- is not damaged due to long time exposure to reverse connected battery.

Clamping voltage is the voltage the TVS diode clamps in high-current pulse situations. This voltage is much higher than the breakdown voltage. TVS diodes are designed to clamp transient pulses and must not interfere with steady-state operation. In the case of an ISO 7637-2 pulse 1, the input voltage goes up to  $-150\text{ V}$  with a generator impedance of  $10\ \Omega$ . This behavior translates to  $15\text{ A}$  flowing through the TVS- and the voltage across the TVS is close to the clamping voltage.

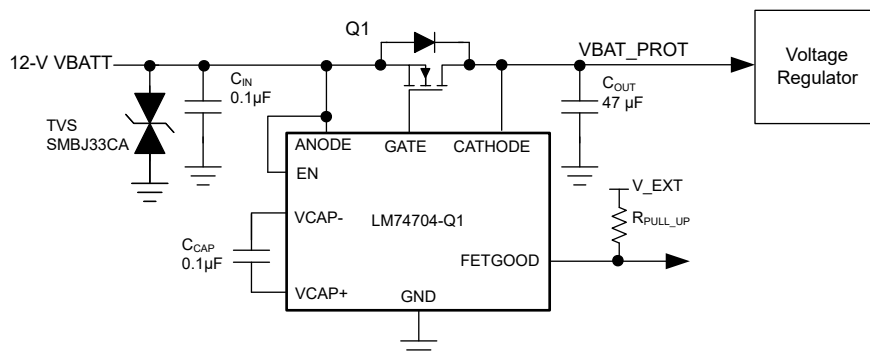

**Figure 9-2. Typical 12-V Battery Protection With Single Bidirectional TVS**

The next criterion is that the absolute maximum rating of anode-to-cathode reverse voltage of the LM74703-Q1 and LM74704-Q1 ( $-75\text{ V}$ ) and the maximum  $V_{DS}$  rating MOSFET must not be exceeded. In the design example, 60-V rated MOSFET is selected and the maximum limit on the cathode to anode voltage is  $60\text{ V}$ .

In case of an ISO 7637-2 pulse 1, the anode of LM74703-Q1, LM74704-Q1 is pulled down by the ISO pulse and clamped by TVS-. The MOSFET is turned off quickly to prevent reverse current from discharging the bulk output capacitors. When the MOSFET turns off, the cathode to anode voltage seen is equal to (TVS Clamping voltage + Output capacitor voltage). If the maximum voltage on output capacitor is  $16\text{ V}$  (maximum battery voltage), then the clamping voltage of the TVS- must not exceed  $(60\text{ V} - 16)\text{ V} = -44\text{ V}$ .

The SMBJ33CA TVS diode can be used for 12-V battery protection applications. The breakdown voltage of  $36.7\text{ V}$  meets the jump start, load dump requirements on the positive side and  $16\text{-V}$  reverse battery connection on the negative side. During an ISO 7637-2 pulse 1 test, the SMBJ33CA clamps at  $-42\text{ V}$  with  $15\text{ A}$  of peak surge current as shown in Figure 9-5 and meets the clamping voltage  $\leq 44\text{ V}$ .

The SMBJ series of TVS diodes are rated up to  $600\text{-W}$  peak pulse power levels. This rating is sufficient for ISO 7637-2 pulses and suppressed load dump (ISO-16750-2 pulse B).

### 9.2.2.5 Selection of TVS Diodes and MOSFET for 24-V Battery Protection Applications

A typical 24-V battery protection application circuit shown in Figure 9-3. This circuit uses two unidirectional TVS diodes to protect from positive and negative transient voltages.

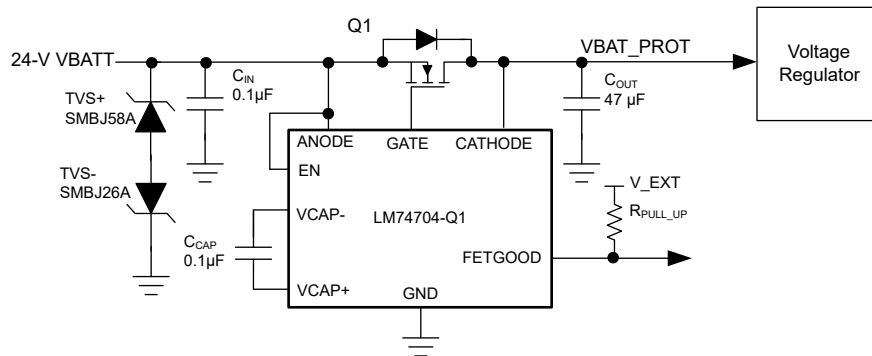

Figure 9-3. Typical 24-V Battery Protection With Two Unidirectional TVS

The breakdown voltage of the TVS+ must be higher than the 48-V jump start voltage, less than the absolute maximum ratings of the anode and enable pin of the LM74703-Q1 and LM74704-Q1 (65 V) and must withstand 65-V suppressed load dump. The breakdown voltage of TVS- must be lower than the maximum reverse battery voltage  $-32$  V, so that the TVS- is not damaged due to long time exposure to reverse connected battery.

During ISO 7637-2 pulse 1, the input voltage goes up to  $-600$  V with a generator impedance of  $50 \Omega$ . This behavior translates to 12 A flowing through the TVS-. The clamping voltage of the TVS- can not be the same as that of the 12-V battery protection circuit because during the ISO 7637-2 pulse, the ANODE to CATHODE pin voltage seen is equal to  $(-TVS \text{ Clamping voltage} + \text{Output capacitor voltage})$ . For a 24-V battery application, the maximum battery voltage is 32 V, which indicates that the clamping voltage of the TVS- must not exceed,  $75 \text{ V} - 32 \text{ V} = 43 \text{ V}$ .

Single bidirectional TVS can not be used for 24-V battery protection because breakdown voltage for TVS+  $\geq 65$  V, maximum clamping voltage is  $\leq 43$  V and the clamping voltage can not be less than the breakdown voltage. Two unidirectional TVS that are connected back-to-back need to be used at the input. For the positive side TVS+, the SMBJ58A with the breakdown voltage of 64.4 V (minimum), 67.8 (typical) is recommended. For the negative side TVS-, the SMBJ26A with breakdown voltage close to 32 V (to withstand maximum reverse battery voltage of  $-32$  V) and maximum clamping voltage of 42.1 V is recommended.

For 24-V battery protection, a 75-V rated MOSFET is recommended to be used along with the SMBJ26A and SMBJ58A connected back-to-back at the input.

### 9.2.3 Application Curves

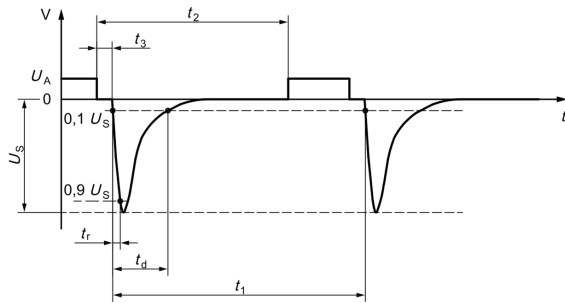
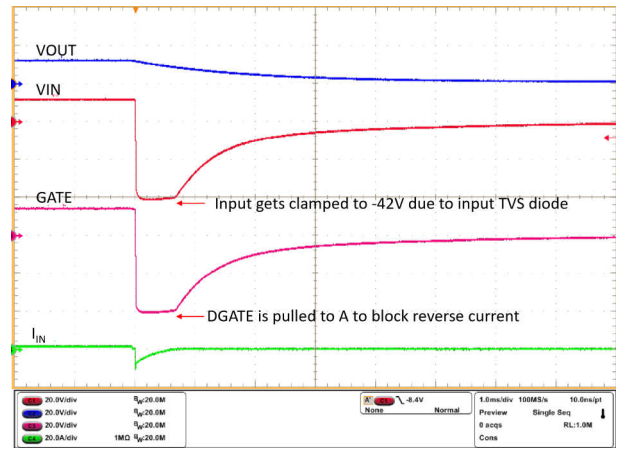
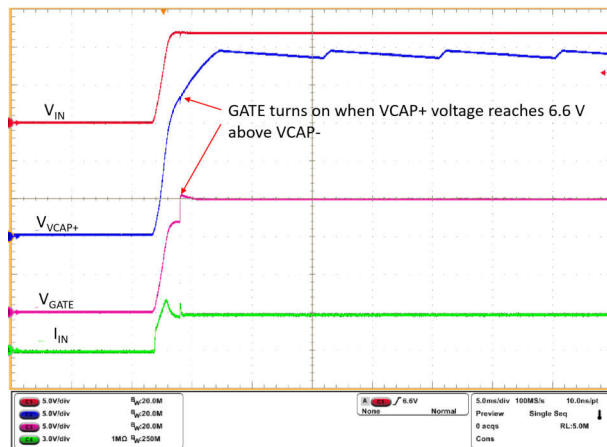

Figure 9-4. ISO 7637-2 Pulse 1



Time (1 ms/DIV)

Figure 9-5. Response to ISO 7637-2 Pulse 1



Time (5 ms/DIV)

Figure 9-6. Start-up With 3-A Load

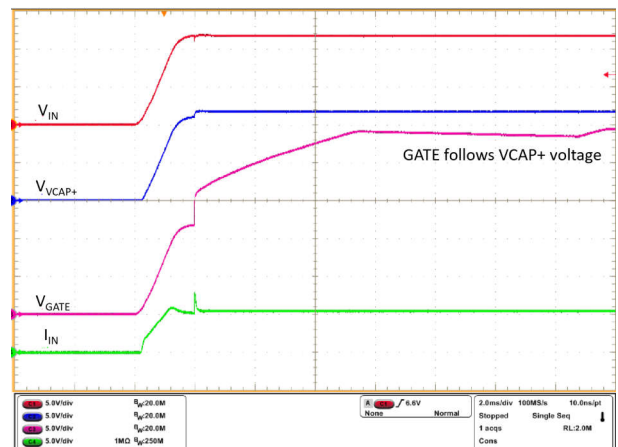

Time (2 ms/DIV)

Figure 9-7. Start-up With 5.8-A Load

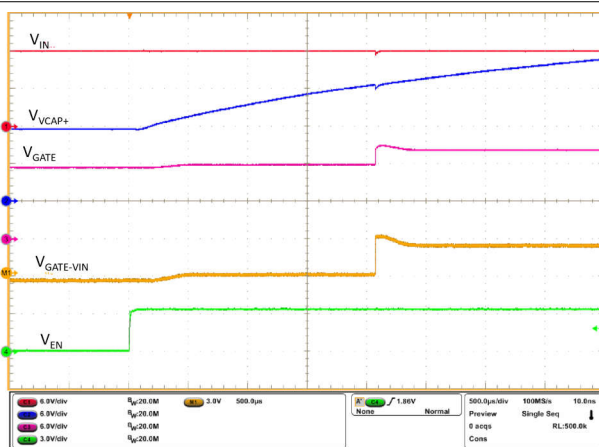

Time (0.5 ms/DIV)

Figure 9-8. Device Start-up With EN Toggle

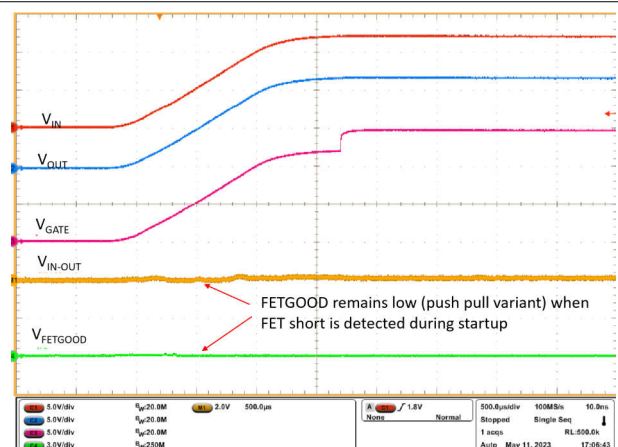

Time (0.5 ms/DIV)

Figure 9-9. FETGOOD During Start-up With FET Short (LM74703-Q1)

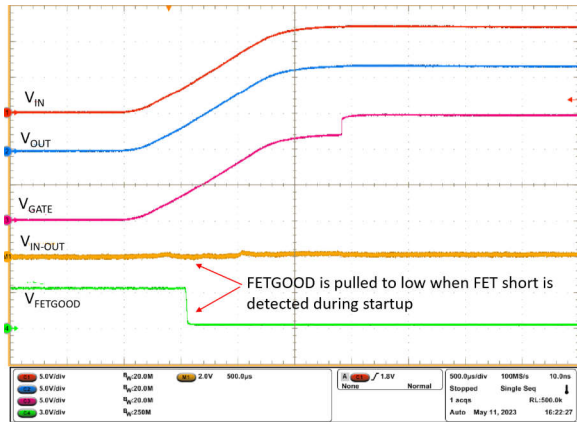

Time (0.5 ms/DIV)

Figure 9-10. FETGOOD During Start-up With FET Short (LM74704-Q1)

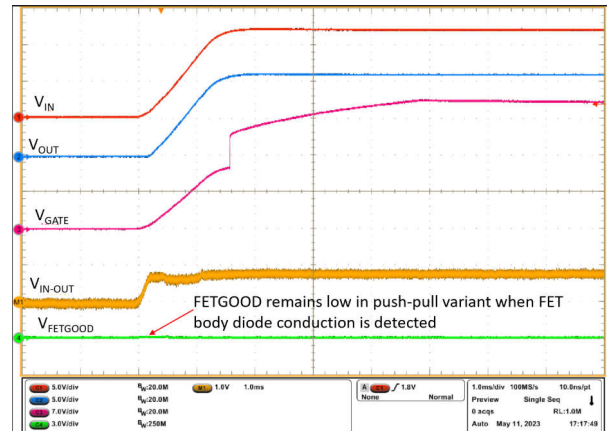

Time (1 ms/DIV)

Figure 9-11. FETGOOD During Start-up With FET Off or GATE Pin Open (LM74703-Q1)

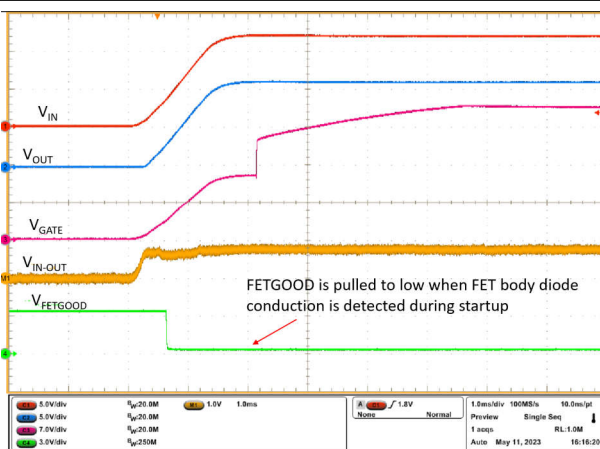

Time (1 ms/DIV)

Figure 9-12. FETGOOD During Start-up With FET Off or GATE Pin Open (LM74704-Q1)

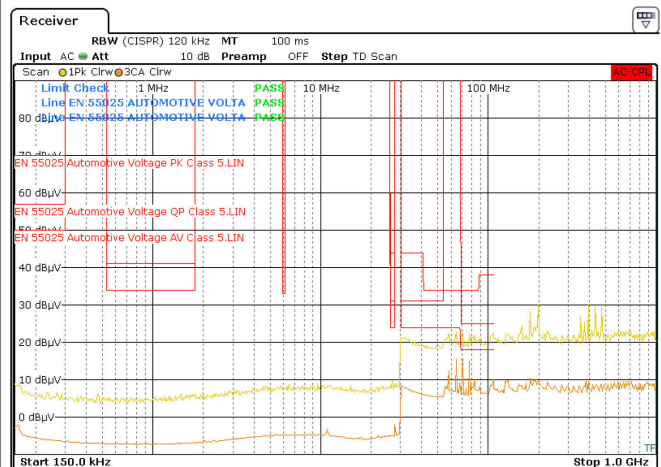

Figure 9-13. LM74703-Q1, LM74704-Q1 Conducted EMI Performance (150 kHz to 1 GHz)

## 9.3 Power Supply Recommendations

The LM74703-Q1, LM74704-Q1 Ideal Diode Controller is designed for the supply voltage range of  $3.2\text{ V} \leq V_{\text{ANODE}} \leq 65\text{ V}$ . If the input supply is located more than a few inches from the device, an input ceramic bypass capacitor higher than 100 nF is recommended. To prevent LM74703-Q1 and surrounding components from damage under the conditions of a direct output short circuit, using a power supply with overload and short circuit protection is necessary.

## 9.4 Layout

### 9.4.1 Layout Guidelines

- Connect ANODE, GATE, and CATHODE pins of LM74703-Q1, LM74704-Q1 close to the SOURCE, GATE, and DRAIN pins of the MOSFET.
- The high current path of this design is through the MOSFET, using thick traces for source and drain of the MOSFET to minimize resistive losses is important.
- The charge pump capacitor across VCAP+ and VCAP– pins must be kept away from the MOSFET to lower the thermal effects on the capacitance value.
- The GATE pin of the LM74703-Q1, LM74704-Q1 must be connected to the MOSFET gate with a short trace. Avoid excessively thin and long traces to the Gate Drive.
- Keep the GATE pin close to the MOSFET to avoid increases in MOSFET turn-off delay due to trace resistance.
- Obtaining acceptable performance with alternate layout schemes is possible, however the layout shown in the [Layout Example](#) is intended as a guideline and produces good results.

### 9.4.2 Layout Example

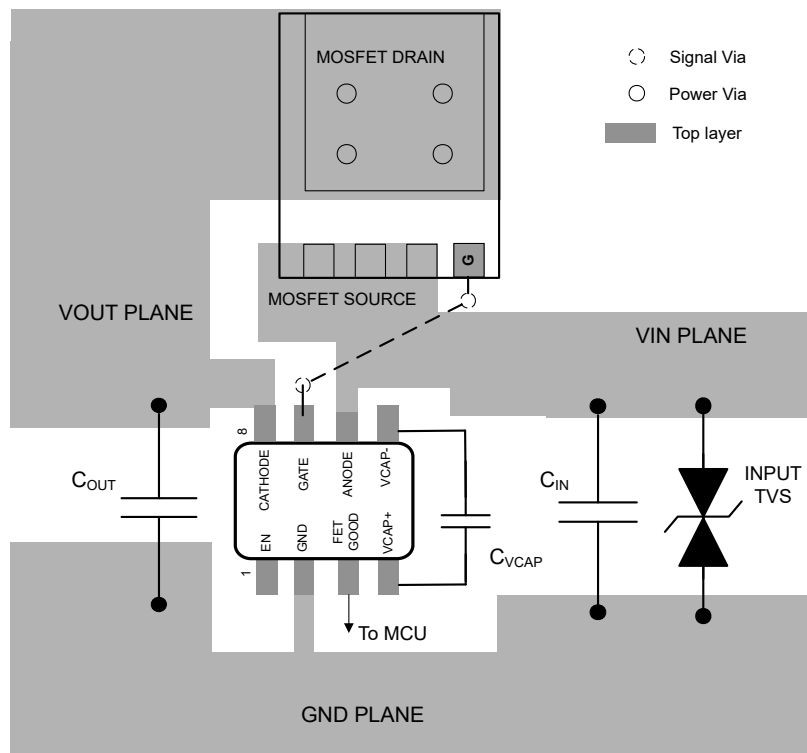

Figure 9-14. LM74703-Q1 DDF Package Example Layout

## 10 Device and Documentation Support

### 10.1 Documentation Support

#### 10.1.1 Related Documentation

Texas Instruments, [LM74704Q1EVM: LM74704-Q1 and LM74703-Q1 evaluation module for ideal diode controllers](#), product page

### 10.2 Receiving Notification of Documentation Updates

To receive notification of documentation updates, navigate to the device product folder on [ti.com](#). Click on *Notifications* to register and receive a weekly digest of any product information that has changed. For change details, review the revision history included in any revised document.

### 10.3 Support Resources

[TI E2E™ support forums](#) are an engineer's go-to source for fast, verified answers and design help — straight from the experts. Search existing answers or ask your own question to get the quick design help you need.

Linked content is provided "AS IS" by the respective contributors. They do not constitute TI specifications and do not necessarily reflect TI's views; see TI's [Terms of Use](#).

### 10.4 Trademarks

TI E2E™ is a trademark of Texas Instruments.  
All trademarks are the property of their respective owners.

### 10.5 Electrostatic Discharge Caution



This integrated circuit can be damaged by ESD. Texas Instruments recommends that all integrated circuits be handled with appropriate precautions. Failure to observe proper handling and installation procedures can cause damage.

ESD damage can range from subtle performance degradation to complete device failure. Precision integrated circuits may be more susceptible to damage because very small parametric changes could cause the device not to meet its published specifications.

### 10.6 Glossary

[TI Glossary](#) This glossary lists and explains terms, acronyms, and definitions.

## 11 Revision History

NOTE: Page numbers for previous revisions may differ from page numbers in the current version.

<b>Changes from Revision * (May 2023) to Revision A (December 2023)</b>	<b>Page</b>
• Changed the document status from <i>Advanced Information</i> to <i>Production</i> data .....	<b>1</b>

## 12 Mechanical, Packaging, and Orderable Information

The following pages include mechanical, packaging, and orderable information. This information is the most current data available for the designated devices. This data is subject to change without notice and revision of this document. For browser-based versions of this data sheet, refer to the left-hand navigation.

**PACKAGING INFORMATION**

Orderable Device	Status (1)	Package Type	Package Drawing	Pins	Package Qty	Eco Plan (2)	Lead finish/ Ball material (6)	MSL Peak Temp (3)	Op Temp (°C)	Device Marking (4/5)	Samples
LM74703QDDFRQ1	ACTIVE	SOT-23-THIN	DDF	8	3000	RoHS & Green	SN	Level-1-260C-UNLIM	-40 to 125	L703Q	<a href="#">Samples</a>
LM74704QDDFRQ1	ACTIVE	SOT-23-THIN	DDF	8	3000	RoHS & Green	Call TI	Level-1-260C-UNLIM	-40 to 125	L704Q	<a href="#">Samples</a>

(1) The marketing status values are defined as follows:

**ACTIVE:** Product device recommended for new designs.

**LIFEBUY:** TI has announced that the device will be discontinued, and a lifetime-buy period is in effect.

**NRND:** Not recommended for new designs. Device is in production to support existing customers, but TI does not recommend using this part in a new design.

**PREVIEW:** Device has been announced but is not in production. Samples may or may not be available.

**OBSELETE:** TI has discontinued the production of the device.

(2) **RoHS:** TI defines "RoHS" to mean semiconductor products that are compliant with the current EU RoHS requirements for all 10 RoHS substances, including the requirement that RoHS substance do not exceed 0.1% by weight in homogeneous materials. Where designed to be soldered at high temperatures, "RoHS" products are suitable for use in specified lead-free processes. TI may reference these types of products as "Pb-Free".

**RoHS Exempt:** TI defines "RoHS Exempt" to mean products that contain lead but are compliant with EU RoHS pursuant to a specific EU RoHS exemption.

**Green:** TI defines "Green" to mean the content of Chlorine (Cl) and Bromine (Br) based flame retardants meet JS709B low halogen requirements of <=1000ppm threshold. Antimony trioxide based flame retardants must also meet the <=1000ppm threshold requirement.

(3) MSL, Peak Temp. - The Moisture Sensitivity Level rating according to the JEDEC industry standard classifications, and peak solder temperature.

(4) There may be additional marking, which relates to the logo, the lot trace code information, or the environmental category on the device.

(5) Multiple Device Markings will be inside parentheses. Only one Device Marking contained in parentheses and separated by a "~" will appear on a device. If a line is indented then it is a continuation of the previous line and the two combined represent the entire Device Marking for that device.

(6) Lead finish/Ball material - Orderable Devices may have multiple material finish options. Finish options are separated by a vertical ruled line. Lead finish/Ball material values may wrap to two lines if the finish value exceeds the maximum column width.

**Important Information and Disclaimer:**The information provided on this page represents TI's knowledge and belief as of the date that it is provided. TI bases its knowledge and belief on information provided by third parties, and makes no representation or warranty as to the accuracy of such information. Efforts are underway to better integrate information from third parties. TI has taken and continues to take reasonable steps to provide representative and accurate information but may not have conducted destructive testing or chemical analysis on incoming materials and chemicals. TI and TI suppliers consider certain information to be proprietary, and thus CAS numbers and other limited information may not be available for release.

In no event shall TI's liability arising out of such information exceed the total purchase price of the TI part(s) at issue in this document sold by TI to Customer on an annual basis.





**TAPE AND REEL INFORMATION**

**QUADRANT ASSIGNMENTS FOR PIN 1 ORIENTATION IN TAPE**

\*All dimensions are nominal

Device	Package Type	Package Drawing	Pins	SPQ	Reel Diameter (mm)	Reel Width W1 (mm)	A0 (mm)	B0 (mm)	K0 (mm)	P1 (mm)	W (mm)	Pin1 Quadrant
LM74703QDDFRQ1	SOT-23-THIN	DDF	8	3000	180.0	8.4	3.2	3.1	1.25	4.0	8.0	Q3
LM74704QDDFRQ1	SOT-23-THIN	DDF	8	3000	180.0	8.4	3.2	3.1	1.25	4.0	8.0	Q3

**TAPE AND REEL BOX DIMENSIONS**

\*All dimensions are nominal

Device	Package Type	Package Drawing	Pins	SPQ	Length (mm)	Width (mm)	Height (mm)
LM74703QDDFRQ1	SOT-23-THIN	DDF	8	3000	210.0	185.0	35.0
LM74704QDDFRQ1	SOT-23-THIN	DDF	8	3000	210.0	185.0	35.0

# DDF0008A



# PACKAGE OUTLINE

## SOT-23-THIN - 1.1 mm max height

PLASTIC SMALL OUTLINE

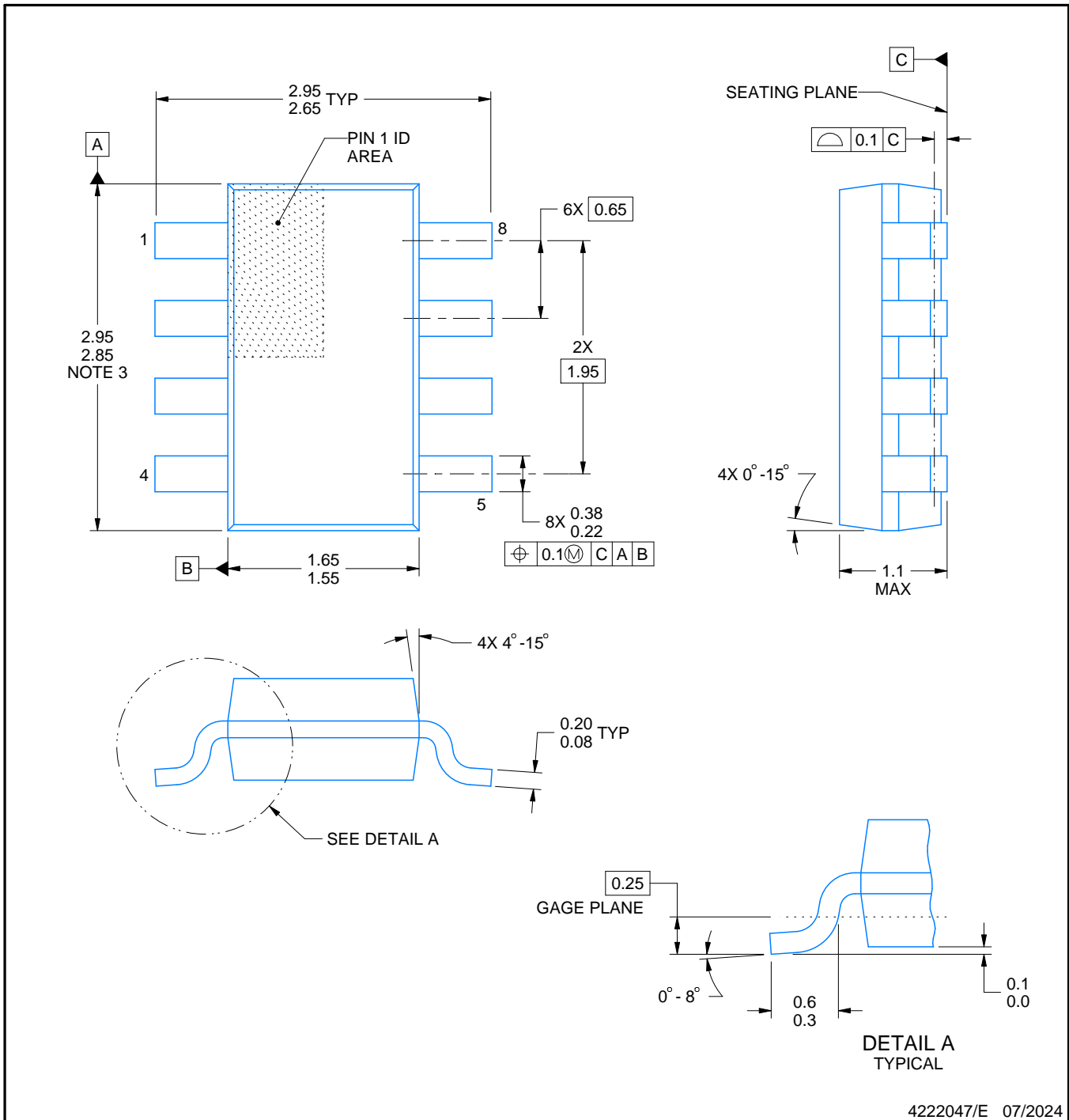

4222047/E 07/2024

**NOTES:**

1. All linear dimensions are in millimeters. Any dimensions in parenthesis are for reference only. Dimensioning and tolerancing per ASME Y14.5M.
2. This drawing is subject to change without notice.
3. This dimension does not include mold flash, protrusions, or gate burrs. Mold flash, protrusions, or gate burrs shall not exceed 0.15 mm per side.

# EXAMPLE BOARD LAYOUT

DDF0008A

SOT-23-THIN - 1.1 mm max height

PLASTIC SMALL OUTLINE

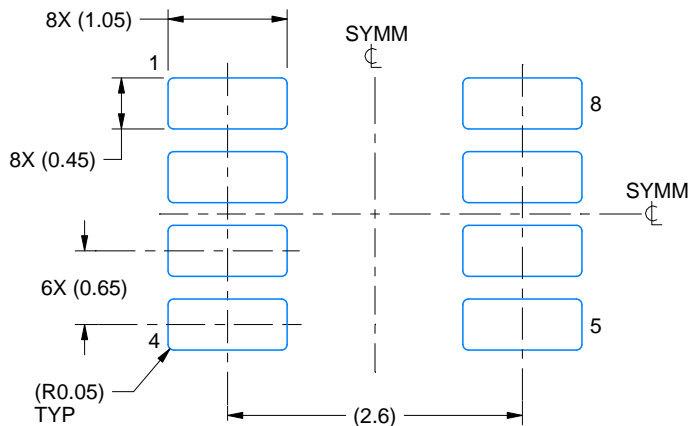

LAND PATTERN EXAMPLE  
EXPOSED METAL SHOWN  
SCALE:15X

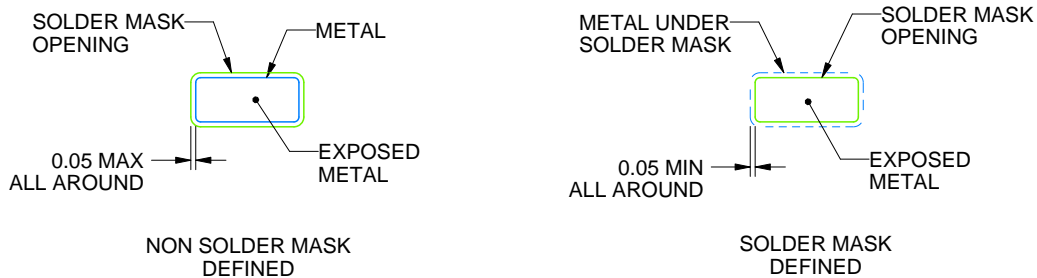

SOLDER MASK DETAILS

4222047/E 07/2024

NOTES: (continued)

- 4. Publication IPC-7351 may have alternate designs.
- 5. Solder mask tolerances between and around signal pads can vary based on board fabrication site.

# EXAMPLE STENCIL DESIGN

DDF0008A

SOT-23-THIN - 1.1 mm max height

PLASTIC SMALL OUTLINE

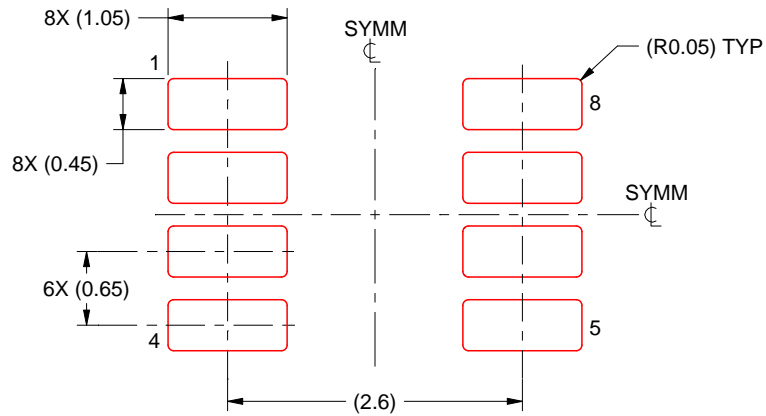

SOLDER PASTE EXAMPLE  
BASED ON 0.125 mm THICK STENCIL  
SCALE:15X

4222047/E 07/2024

NOTES: (continued)

6. Laser cutting apertures with trapezoidal walls and rounded corners may offer better paste release. IPC-7525 may have alternate design recommendations.
7. Board assembly site may have different recommendations for stencil design.

## IMPORTANT NOTICE AND DISCLAIMER

TI PROVIDES TECHNICAL AND RELIABILITY DATA (INCLUDING DATA SHEETS), DESIGN RESOURCES (INCLUDING REFERENCE DESIGNS), APPLICATION OR OTHER DESIGN ADVICE, WEB TOOLS, SAFETY INFORMATION, AND OTHER RESOURCES "AS IS" AND WITH ALL FAULTS, AND DISCLAIMS ALL WARRANTIES, EXPRESS AND IMPLIED, INCLUDING WITHOUT LIMITATION ANY IMPLIED WARRANTIES OF MERCHANTABILITY, FITNESS FOR A PARTICULAR PURPOSE OR NON-INFRINGEMENT OF THIRD PARTY INTELLECTUAL PROPERTY RIGHTS.

These resources are intended for skilled developers designing with TI products. You are solely responsible for (1) selecting the appropriate TI products for your application, (2) designing, validating and testing your application, and (3) ensuring your application meets applicable standards, and any other safety, security, regulatory or other requirements.

These resources are subject to change without notice. TI grants you permission to use these resources only for development of an application that uses the TI products described in the resource. Other reproduction and display of these resources is prohibited. No license is granted to any other TI intellectual property right or to any third party intellectual property right. TI disclaims responsibility for, and you will fully indemnify TI and its representatives against, any claims, damages, costs, losses, and liabilities arising out of your use of these resources.

TI's products are provided subject to [TI's Terms of Sale](#) or other applicable terms available either on [ti.com](https://www.ti.com) or provided in conjunction with such TI products. TI's provision of these resources does not expand or otherwise alter TI's applicable warranties or warranty disclaimers for TI products.

TI objects to and rejects any additional or different terms you may have proposed.

Mailing Address: Texas Instruments, Post Office Box 655303, Dallas, Texas 75265

Copyright © 2025, Texas Instruments Incorporated