



# Building your application with security in mind



Guide to embedded security

**1**

Chapter 1: Introduction to cybersecurity

- 1.1. Why does security matter?
- 1.2. Security framework: view of a typical embedded application

**2**

Chapter 2: Risk assessment and security discovery process

- 2.1. Threats or threat modeling (attackers capabilities and attack surfaces)
- 2.2. Map your security measures to security enablers
- 2.3. Security discovery process examples
- 2.4. Selecting the appropriate device

**3**

Chapter 3: How to implement security

- 3.1. Terminology
- 3.2. Detailed security goals and definitions
- 3.3. Elements for building an embedded application with security features

**4**

Chapter 4: Threats and adversaries

- 4.1. Network threats
- 4.2. Board threats
- 4.3. Chip threats
- 4.4. Some examples of consequences of poor security
- 4.5. Leveraging industry standards and specifications for security

**5**

Chapter 5: TI and security

- 5.1. A long history

**6**

Chapter 6: Overview of TI solutions to help implement security measures

- 6.1. SimpleLink™ Bluetooth® low energy
- 6.2. SimpleLink Sub-1 GHz
- 6.3. SimpleLink Wi-Fi®
- 6.4. C2000
- 6.5. SimpleLink MSP432™ MCUs
- 6.6. MSP430™ MCUs
- 6.7. Processors
- 6.8. Auto processors

**7**

Conclusion

**8**

Appendix

- 8.1. Resources



# Introduction

Security is paramount in our increasingly connected and complex world. Security and cybersecurity have become top concerns and gained a lot of international attention through news reports of recent attacks and data breaches. These events have underscored the need for designers to improve security from endpoint to endpoint.

Looking at the Internet of Things (IoT) for instance, security is necessary in industrial applications like building and home automation, smart grids, appliances, factory automation, personal electronics and automotive. Designers must take security seriously, conducting a thorough risk evaluation and selecting appropriate measures so that their application protects user privacy and defends consumers against fraudulent actions – all while providing the proper functionality and services.

In this context, the question arises: How do you achieve your desired level of security in connected devices? Achieving a sufficiently good level of security requires a lot of effort, investment and time. This e-book will provide an overview of why security matters, how to evaluate which security measures you need, and how to implement these measures against threats and adversaries. We will also take a look at the main security enablers that Texas Instruments (TI) offers to assist you in furthering your security objectives.

# 1 Chapter 1: Introduction to cybersecurity

As the world continues to seek greater convenience, the internet and the devices connected to it have become a predominant tool in our lives. However, this connection to the internet comes with a range of drawbacks that are somewhat tolerable – such as a partial loss of data on social media, or not – like the loss of personal information and privacy. Preserving privacy also means preserving human rights and freedom, which is why cybersecurity has become a major concern for many types of applications, especially those that connect to the internet or to each other.

Cybersecurity is no longer something that only concerns a small group of experts. It concerns us all and has spread into nearly every corner of daily life. All designs requiring security or involving some aspect of security must be taken seriously (and with a lot of humility) from the very first day of a project.

While integrated circuits (ICs) like microcontrollers (MCUs), processors and wireless connectivity devices do not

constitute a complete solution for securing an application, they can provide the building blocks for you to use to incorporate security features into your application. These are various types of security features that enable and assist designers in reducing the security risk consistent with their intended end application and design requirements. At TI, we have partitioned these features into 12 categories in order to help our customers easily identify the security features that are pertinent to their applications. We call these categories “security enablers”.

## 1.1. Why does security matter?

Why should system architects, designers and engineers concern themselves with the security of the products they create?

When designers think about the word “security,” there are inevitably other terms that come to mind, such as “privacy,” “safety,” “protection” and “defense.” The broad

topic of security actually encompasses and embraces all of these other terms. To maintain privacy, consumers create passwords for online accounts, establish PINs for payment cards and give fingerprints to prove their identity. These actions are intended to “secure” personal information, or in some cases to “secure” individuals or property from harm, as much as possible.

Anything precious and valuable is worth securing. But an obvious question arises: From whom or what are we securing these precious items? In the modern world, security measures are intended to defend against other people. This type of security is both a unique human need and a unique human problem because, while obvious, items of value to one person are likely to be items of value to many others.

**Security enabler:** A category of security features that TI devices may support. They can help customers achieve their security objectives.

In the modern digital world, many precious items have moved from being tangible, analog things to digital bits. For example, the money in bank accounts is just a set of bytes in a database; photographs and favorite songs are simply files on smartphones or computers (now more commonly in the cloud); and communications – text messages, chat logs, emails, voice calls, social media posts, etc. – are all packets of digital data moving in and around a vast digital network spanning the globe.

But these things are no less valuable just because they are collections of bits rather than the tangible objects they represent. Consumers value photos, music and other data, so they try to prevent attackers from getting into devices and modifying their content. Because individuals value privacy and freedom from unauthorized parties knowing what they say and who they say it to, there is a

conscious attempt to protect communications from being intercepted. Because users want to protect their online identity and reputation, efforts are made to prevent others from accessing accounts and impersonating them online. This is all security.

## 1.2. Security framework: a view of a typical embedded application

Everything starts at the application level. As shown in **Figure 1**, designers will typically want to protect their customer assets against threats by implementing security measures. At the semiconductor level, the main assets in a system that need protection are data, code, device identities and keys. This e-book intends to help developers understand how to identify their “customer assets” and categorize them into one of these three categories at the semiconductor level.

The exposure points (often referred to as the “attack surface”) in a system can increase the vulnerability of assets at each part of the application/system life cycle and operations. Exposure points in a system can be broadly categorized as storage, run-time or transfer operations.

TI offers security enablers in order to help designers implement their security measures. Based on the assets that need protection and the exposure points, you should consider all of the appropriate security enablers and then select security features at the device level to design appropriate protection. The green blocks in **on the next page** are 12 security enablers that we will define in the next section.

**Assets:** The objects (either physical or logical) that you want to protect. An asset can be firmware that a user loads onto a device, data transmitted over a network or key material stored on a device.

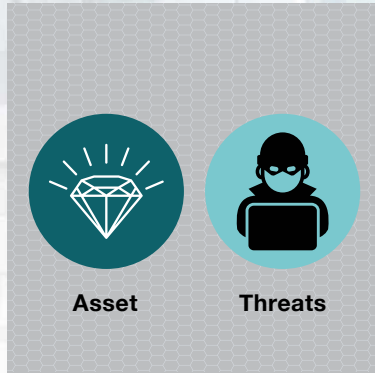

It starts with an asset you want to protect against different types of threats.

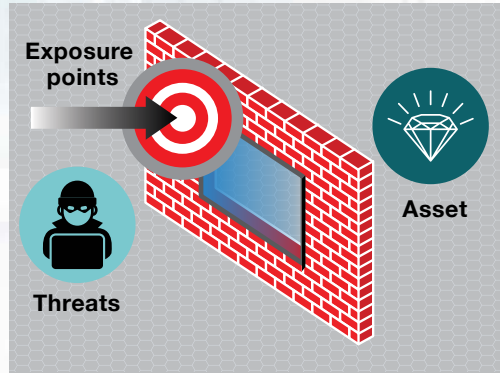

In the real world, there can be holes in the protection called exposure points.

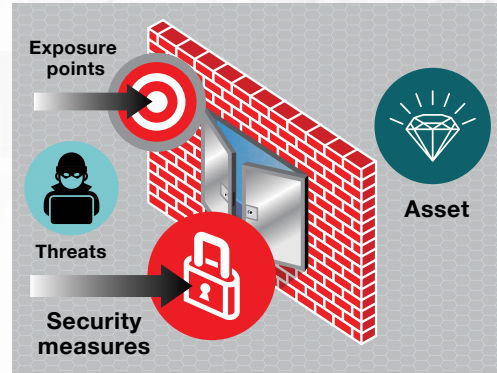

To protect those asset, you would implement security measures.

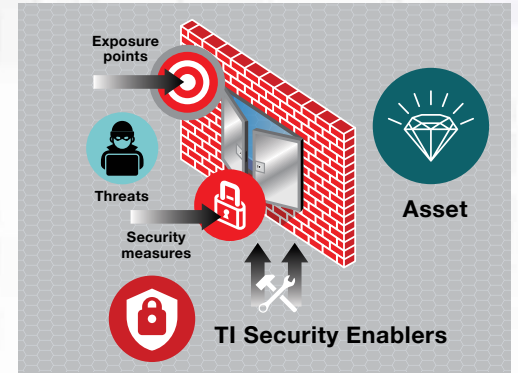

TI delivers different types of security enablers to help you address the emerging threats and implement security measures to protect your asset.

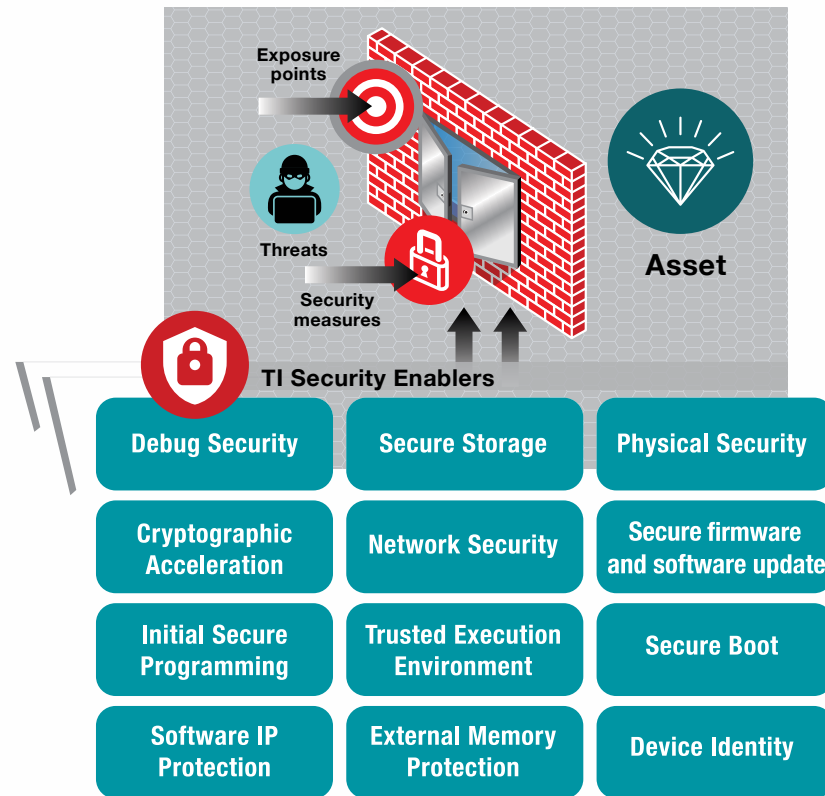

Figure 1 - Security framework.

# 2

## Chapter 2: Risk assessment and security discovery process

It's safe to assume that someone with sufficient motivation, expertise, equipment and time can break any security measure. With this in mind, a discussion on security requirements must weigh the cost and effort of implementing security against the value of what is being secured and the assumed cost of mounting a successful attack.

**Security:** using an objective and holistic risk analysis, a designer may assess an asset as secure if the designer has confidence in determining that the value of the protected asset is smaller than the cost of the cheapest attack that compromises this asset.

A risk assessment should consist of two steps: a qualitative risk assessment first (identifying the vulnerabilities, threats, threat probabilities and measures) and a quantitative risk

assessment (quantifying loss in case a threat is realized, such as mapping a dollar amount to a specific risk).

This principle revolves around three fundamental questions:

- What is being protected? (asset)
- Who or what are you protecting against? (threat and threat probability)
- What is the attack surface? (exposure points and threat probability)

You must start with a good understanding of the targeted application and then conduct a risk assessment to identify

which security measures will mitigate the threats and which are possible to implement in your system. Once identified, you can connect the security measures to actual security enablers (security features in TI devices). This leads to the identification of an embedded device that may contain the right ingredients (security features) to implement these security measures. The flow chart in **figure 2** describes this process, sometimes iterative, but we will explain it in further detail in the following sections.

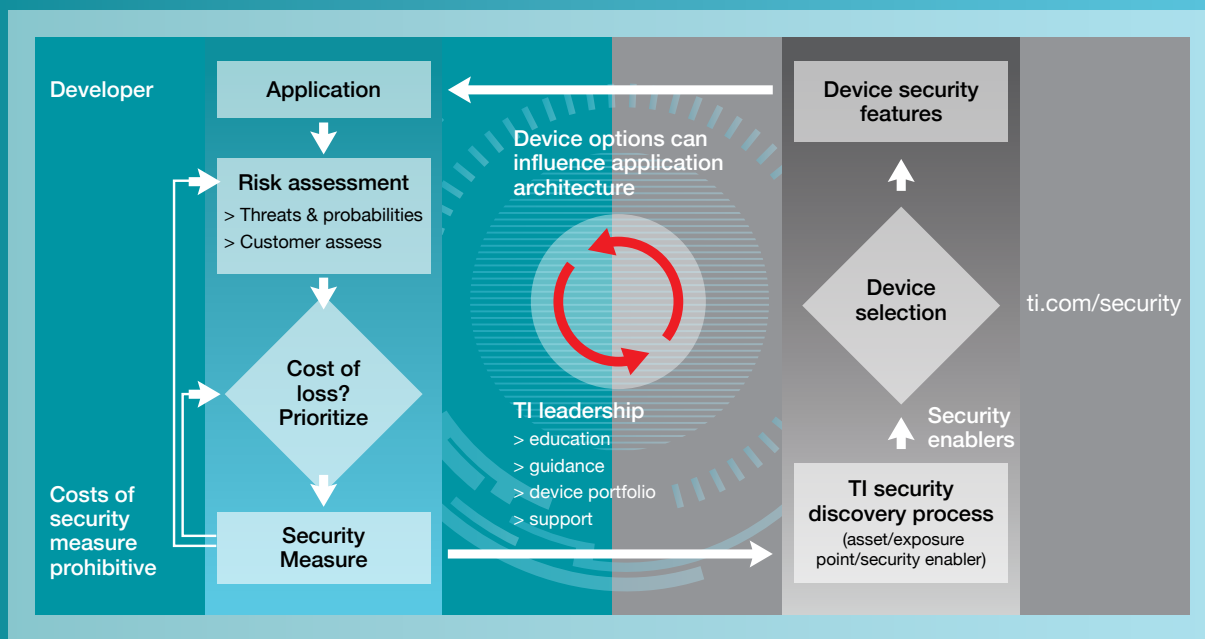

Figure 2 - Security implementation cycle: developer's responsibilities and devices with security enablers.

## 2.1. Threats or threat modeling (attackers capabilities and attack surfaces)

A practical way to classify the type of threats that any design has to consider is to view it from a system access perspective. The attacker poses three main types of threats: from the network (remote: internet), the board (close proximity) and the chip (physical attacks) as shown in **figure 3**.

- Network threats include any communication channel (either wired or wireless) that allows a remote attacker not present at the location or in close proximity to the device to attack it.
- Board threats target printed circuit board (PCB) access and use any wired interface on the chip.
- Chip threats infiltrate device access to perform integrated circuit (IC) decapsulation and deprocessing to gain access to the internal layers and elements of the chip.

See **table 1** for the full definition of these threats.

Threats differ based on the level of access and the level of equipment and capabilities attackers might have (attack surface and attack vector). Each level simply refers to particular attack surfaces and vector sets that you need to consider. The types help you quickly determine the resistance goals of particular applications and tailor which security measures to implement. For example, chip threats

are typically not considered for connected products, as the potentially riskiest attack for that type of product is one that can be reproduced and scaled to many devices, potentially an entire area/city.

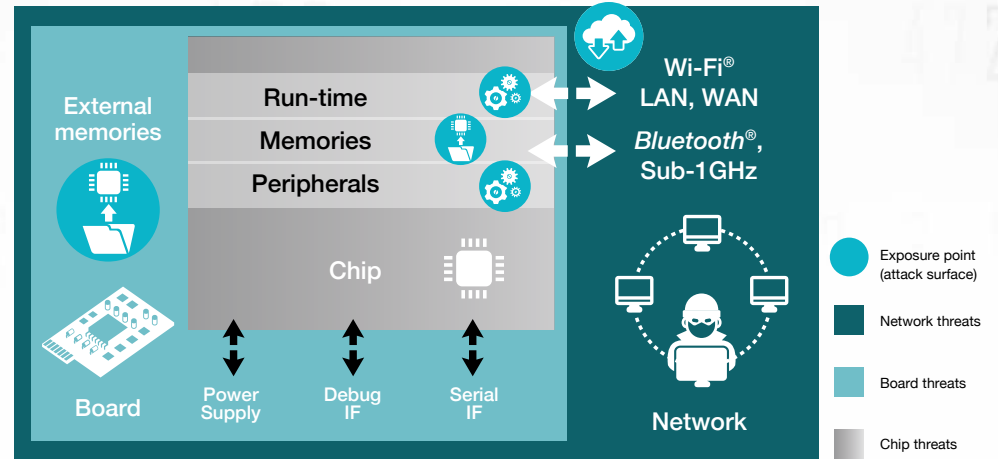

Figure 3 - Threat types in an embedded system.



Threat Categories	Threat Definition	Capabilities
 Network	Signal analyst with only remote access, wired or wireless (no direct physical access).	The attacker accesses the system through the wide area network (WAN) or other wireless protocol. It can communicate with the device, impersonate another device, etc. The attacker can also be located in close proximity to the device. It can monitor or modify inbound/outbound wireless communication/or unintended emissions. It can attack the wireless physical layer. It can also perform network timing attacks.
 Board	Hobbyist or electrical engineering lab with physical access to device.	The attacker has access to the PCB. They can monitor interactions with the device using wired interfaces for communication (Serial Peripheral Interface [SPI], Inter-Integrated Circuit Protocol [I <sup>2</sup> C], universal asynchronous receiver transmitter [UART]), debugging (Joint Test Action Group [JTAG]) or power supply (electromagnetic/power analysis). They can also trace and manipulate the wired interfaces of the device. They will modify the PCB and actively try to create the conditions that lead to the targeted access retrieval.
 Chip	Professional hacking companies, universities, lab, spy agencies.	The attacker has a sufficient amount of time and full physical access to the product. They can delaminate a package to get access to the device's internal layers. In this category, the main examples of attacks are microprobing, fault attack (laser, light, etc.) of the Integrated Circuit, but also reverse engineering of the read-only memory (ROM). The attacker delaminates the package to access the device's internal layers and uses a panoply of sophisticated silicon analysis tools: focus ion beam (FIB), scanning electron microscope (SEM), EmiScope (EMI) or atomic force microscope (AFM).

Table 1 - Threat categories.



If the cost of a system attack is higher than the total value of the asset, then it is reasonable to assume that a successful attack will not be mounted. When considering such risks, note that some attacks are expensive to develop but can be inexpensive to repeat. For example, an attack that relies on wafer backgrinding\* and observing the active components to extract assets from a device requires both significant expertise and equipment to execute, and this expertise and equipment is required each time the attack is repeated. In contrast, there are attacks that obtain an invariant secret used in a device family to unlock it for retest or failure analysis purposes. Obtaining the secret may involve equipment and expertise rivaling the first attack in cost; however once obtained, the secret may be used to mount repeated attacks, making this effectively very low cost compared to acquiring access to the whole system. This attack presents a high risk.

\*Wafer backgrinding is a semiconductor device fabrication step during which wafer thickness is reduced.

There are many techniques for analyzing security risks. Generally, within the security space, risk analysis techniques are referred to as “threat modeling.” Each risk analysis technique comes with its own pros and cons, in addition to specific industry standards (official or de facto) that specify which technique(s) to use. We provide further details and possible methods in [Section 3.3](#) to help designers carry out this threat modeling step in a more rigorous way.

In the threat modeling process, it is very common that the identification of threats leads to the identification of assets, and vice versa. For example, you may not consider a piece of software an asset, but when considering the threats when a device is connected, that piece of software could be updated, which would lead to the control of all devices in the network; therefore, a piece of software and its control suddenly becomes a very important asset.

**Table 2** shows three different scenarios that use the TI security discovery process. This process should guide you towards the security enablers that are most relevant to your security objectives, but it does not replace a full analysis (following one of the possible tools we suggest in [Section 3.3](#)).

Defining the security measure is a necessary step to identify the security enablers you need at the device level.



Scenarios	Baby Monitor	Payment Terminal (Electronic Point of Sale [ePOS])	Electronic Door Lock (E-Lock)
Threat 	Attackers can eavesdrop and access the video/audio of a baby monitor to determine if someone is home.	Attackers can try to physically access a system to manipulate what is displayed, in order to deceive users and steal money.	Attackers can use the debugging interface to access the code and key in order to understand how to open any e-lock of any brand.
Customer Asset 	Video/audio streaming content	Money (data displayed).	Personal possessions (anything that the e-lock protects).
Security Measure 	Encrypt video/audio streaming content.	Add tamper protection to the PCB with a mesh.	Lock the debugging port.

Table 2 - TI security discovery process examples.

## 2.2. Map your security measures to security enablers

Now that you have identified your threats, your (application-level) assets and your security measures, you can map these security measures to the security enablers. We provide this as a tool (**table 4**) to facilitate your device selection process.

The 12 categories of security enablers (the blue boxes in **figure 1**) are somewhat flexible and purposely include overlap. Each category may include dozens of detailed features that help resolve a security threat for a particular market or application. In general, most TI embedded processing systems-on-chip (SoCs) contain at least some basic security enablers, such as secure boot and cryptographic acceleration, on-chip. Some security enablers are only available on specific SoCs, depending on the device's intended applications. **Figure 4** places the security enablers in a pyramid to illustrate the typical layers of an embedded processor/MCU with or without a wireless interface. We recommend starting from the bottom of the pyramid and working toward the top as a typical way to think about the relevant measures.

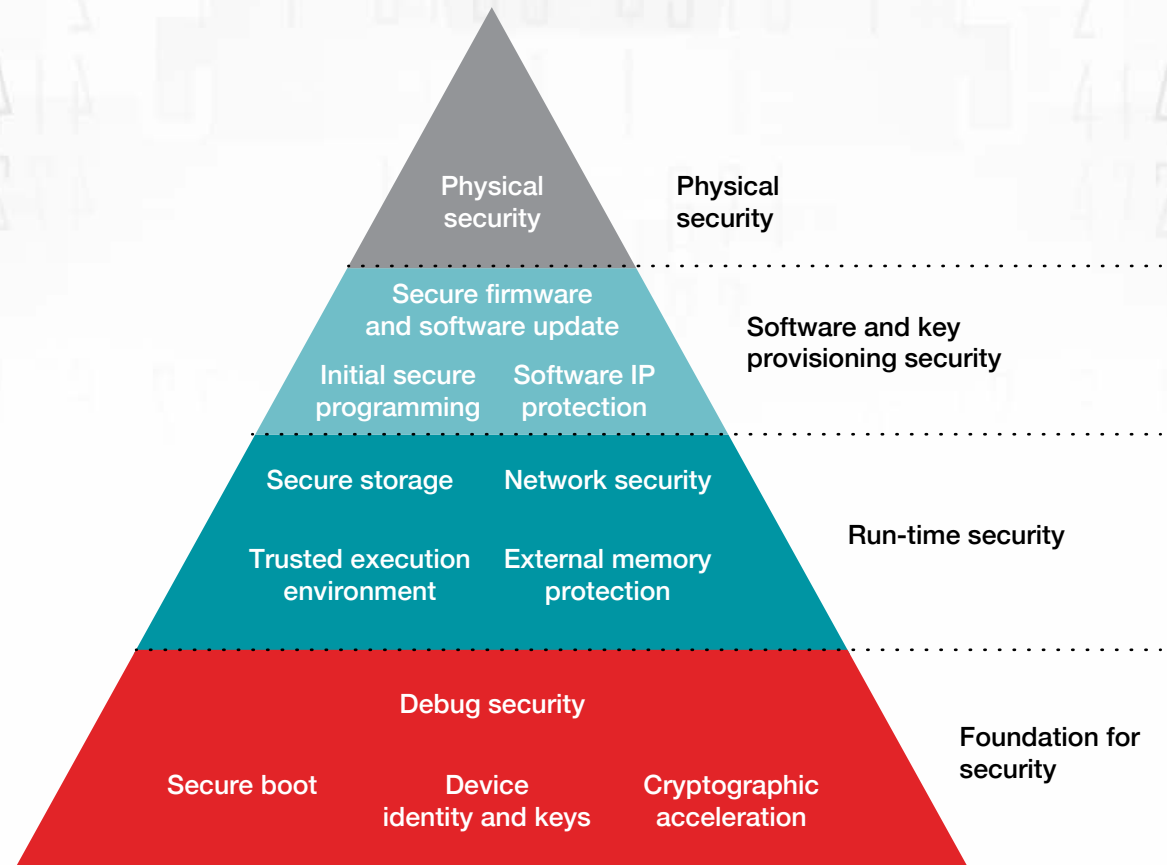

Figure 4 - Typical layers of an embedded processor, with or without a wireless interface.

Security Enabler	Threat Questions	Simple Explanation
Secure Boot	Your application runs off an external flash. How can you make sure that only your software runs on your devices?	Methodologies can help secure the boot process by preventing the loading of software (bootloaders, drivers, operating systems, applications) not signed with an acceptable digital signature.
Device Identity/Keys	How can you identify and authenticate the identity of your device to the network?	You can evaluate and elect to use an identity that TI stores in the devices. It may have the form of a unique ID (UID) and optionally a signature (certificate) key whose public key is easily shareable with a cloud service, for example.
Cryptographic Acceleration	How can you achieve your latency or throughput performance while maintaining your keys/data/code security?	You can leverage the efficiency of dedicated hardware to implement your cryptographic objectives. It can be provided as hardware or as ROM, such as Advanced Encryption Standard (AES) tables. In some cases, the device does not provide cryptographic acceleration, but TI provides generic software C libraries.
Debugging Security	Can somebody use a debugger probe to read out your assets?	You can lock out debugging ports. Some devices will provide various options such as permanent locks, or you can create a password/credential per device to allow reopening of the debugging port.
Trusted Execution Environment (TEE)	Now that you have developed, audited and/or certified your application, how can you make sure that vulnerability in another application running on the same central processing unit (CPU) cannot be exploited to attack your assets: keys, data and code?	A TEE enables you to isolate your application (keys/data/code) at run time from other applications, helping you reduce the risk of security vulnerabilities in other parts of the software. A TEE can either be a physically separated MCU or a virtually isolated processing unit.
Secure Storage	If somebody tampers with your device or finds a software weakness to exploit, are your critical keys and data secure?	Keys and data are stored in a part of the memory that is isolated from the rest of the code and data. TI provides various security features ranging from encrypted blob of keys, anti-tamper modules with master keys, and a private key bus between the nonvolatile memory and the cryptographic accelerators.
External Memory Protection	You want to expand your application with off-chip flash or double-data-rate (DDR) memory. How do you make sure that only your application can run on the CPU?	Quad SPI (QSPI)/external memory interface (EMIF) with execute-in-place provides an easy way to expand your application. The capability to decrypt/authenticate on the fly can assist you in protecting confidentiality/authenticity while allowing only your application to run on the CPU.
Networking Security	How can you get optimal performance while connecting to the network with known protocols?	You can use networking protocol accelerators for Internet Protocol security (IPsec), Transport Layer Security (TLS), or dedicated hardware and firmware to these protocols (A firmware denotes a piece of software in ROM or a piece of software that TI programs at manufacturing ).
Initial Secure Programming (Overbuild Protection Plus Counterfeiting)	You want to program your chip in an untrusted environment (such as a foreign manufacturing facility). How can you ensure that your application/keys are not altered, stolen or replaced?	TI provides a methodology that you can evaluate and elect to use to strengthen the confidentiality, integrity and authenticity of initial firmware or keys programmed in an untrusted facility or during the first boot of the application.
Secure Firmware and Software Update	How can you update your application remotely and securely? Nobody should be able to spy, impersonate or replay your updates.	You can encrypt and sign the updated image for part or all of the application to help mitigate against efforts to spy, impersonate or replay your firmware updates. TI provides various product-dependent features such as over-the-air updates (OTA) while the application is running, hot swap and load for external flash.
Software Intellectual Property (IP) Protection	Your software IP (code) represents a significant investment that you'd like to protect. Can you protect its confidentiality during different parts of your product's life cycle?	Firewalls, IP protection zones/regions, encryption and debugging lockout of part or all of the application are some of the security features that TI provides to help you address these types of concerns.
Physical Security	If somebody has physical access to your application, can they open the package or use the power supply to get access to your assets?	Removing the package and measuring the answer time or power consumed by a protocol request are powerful attacks that anyone with access to the device can use. TI provides various hardware and software features to help you thwart these types of attacks.

Table 3 - Security enabler glossary.

Having identified threats and security measures at the application level, it's time to identify the corresponding assets and exposure points at the semiconductor level, using **table 4** as a guide to select the most appropriate security enablers.

For example, looking at **table 4**, if you wish to protect the asset Code in the situation (exposure point) of Transfer,

you will most likely need to consider the Cryptographic Acceleration, Networking Security, Secure Firmware and Software Update, and Initial Secure Programming security enablers. If you want to protect the Identity & Keys asset in the situation (exposure point) of Transfer, you will most likely need to consider the Cryptographic Acceleration and Networking security enablers.

It's likely that only one (or only a subset) of the securities enablers provided above are pertinent to the problem you are trying to solve. Additional security enablers, outside those provided above, may be necessary to complete your design. At best, **table 4** can help you make a first initial assessment of the possible important security enablers to help you through the selection process.

TI Security Enablers	IDENTITY AND KEYS 			DATA 			CODE 		
	STORAGE 	RUN-TIME 	TRANSFER 	STORAGE 	RUN-TIME 	TRANSFER 	STORAGE 	RUN-TIME 	TRANSFER 
Secure Boot							✓	✓	
Device Identity/Keys	✓		✓				✓	✓	✓
Cryptographic Acceleration	✓		✓	✓		✓	✓		✓
Debugging Security	✓			✓	✓		✓	✓	
TEE		✓			✓			✓	
Secure Storage	✓	✓		✓	✓				
External Memory Protection		✓		✓	✓		✓	✓	
Networking Security			✓		✓				✓
Initial Secure Programming	✓					✓	✓		✓
Secure Firmware and Software Update									✓
Software IP Protection						✓	✓	✓	
Physical Security	✓	✓		✓	✓	✓	✓	✓	

Table 4 - Guide to security enablers based on function of asset and exposure points.

## 2.3. Security discovery process examples

While making an analysis on the security implementation, it is important to be able to address two questions (as displayed in **figure 5**) regarding the asset you need to protect at the device level and the corresponding exposure points as defined in the TI security framework.

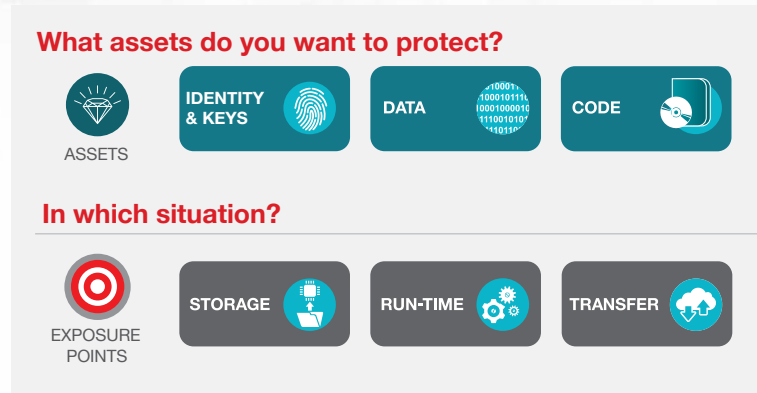

Figure 5 - Fundamental security questions once measures have been established.

**Table 5** takes the three examples from **table 1** and maps them to TI security enablers.

This security discovery process is intended to be an easy first step for identifying the security enablers that pertain to the problem you are trying to solve, and lead to a selection of devices equipped with those security enablers that can help you implement the appropriate measures. It does not provide a foolproof way to identify all of the measures necessary to defeat attacks and attack scenarios. We strongly recommend following the threat modeling process to minimize the risks. See [Section 3.3](#) for some leads and examples.

Scenarios	Baby monitor	Payment terminal (Electronic Point of Sale [ePOS])	Electronic door lock (E-Lock)
Threat 	Attackers can eavesdrop and access the video/audio of a baby monitor to determine if someone is home.	Attackers can try to physically access a system to manipulate what is displayed, in order to deceive users and steal money.	Attackers can use the debugging interface to access the code and key in order to understand how to open any e-lock of any brand.
Customer asset 	Video/audio streaming content	Money (data displayed).	Personal possessions (anything that the e-lock protects).
Measure 	Encrypt video/audio streaming content.	Add tamper protection to the PCB with a mesh.	Lock the debugging port.
Device asset 	Data	Data	Data
Exposure point 	Transfer	Run Time	Storage
Security enabler guide output	<ul style="list-style-type: none"> <li>• Cryptographic Acceleration</li> <li>• Networking Security</li> </ul>	<ul style="list-style-type: none"> <li>• Secure Boot</li> <li>• TEE</li> <li>• Physical Security</li> </ul>	<ul style="list-style-type: none"> <li>• Debugging Security</li> <li>• Secure Storage</li> <li>• Cryptographic Acceleration</li> <li>• Physical Security</li> <li>• External Memory Protection</li> </ul>
Security enabler selected in the context of the security measure	If encryption of the video stream is not possible in software, the solution is: Cryptographic Acceleration	Use anti-tamper techniques: Physical Security	Lock your debugging access: Debugging Security
Example of TI device equipped with such security enablers	SimpleLink™ CC32xx, CC26xx wireless MCUs	Sitara™ AM438xx processor	MSP430FR69xx MCU

Table 5 - Security discovery process examples.

## 2.4. Selecting the appropriate device

The security discovery process allows designers to connect the security measure to the required security enablers. Ultimately, you need to select the appropriate device to support your application. TI offers a large portfolio of MCUs (host and wireless) and processors integrating these security enablers. The product documentation in [Chapter 6](#) provides detailed security features in each security enabler

category. **Figure 6** illustrates as an example the security features incorporated into SimpleLink™ Wi-Fi® CC322x wireless MCUs, which support data (device asset) on the transfer (exposure point) situation.

Overall, developers can use the TI security discovery process which is summarized in **figure 7** below when addressing a security challenge. It is important for the developers to define the security measure as precisely as

possible. At this stage developers can use the TI security discovery process to identify which device may be appropriate for their application and obtain guidance to implement their security measures.

Getting down to the detailed security features		
Asset to Protect	Security Enablers	Detailed Security Features
		AES256
		MD5
		SHA2
		RSA, ECC
		WPA2, WPS
		TLS 1.2
		EAP xxx

Figure 6 - Breakdown of security features of SimpleLink Wi-Fi wireless MCUs.

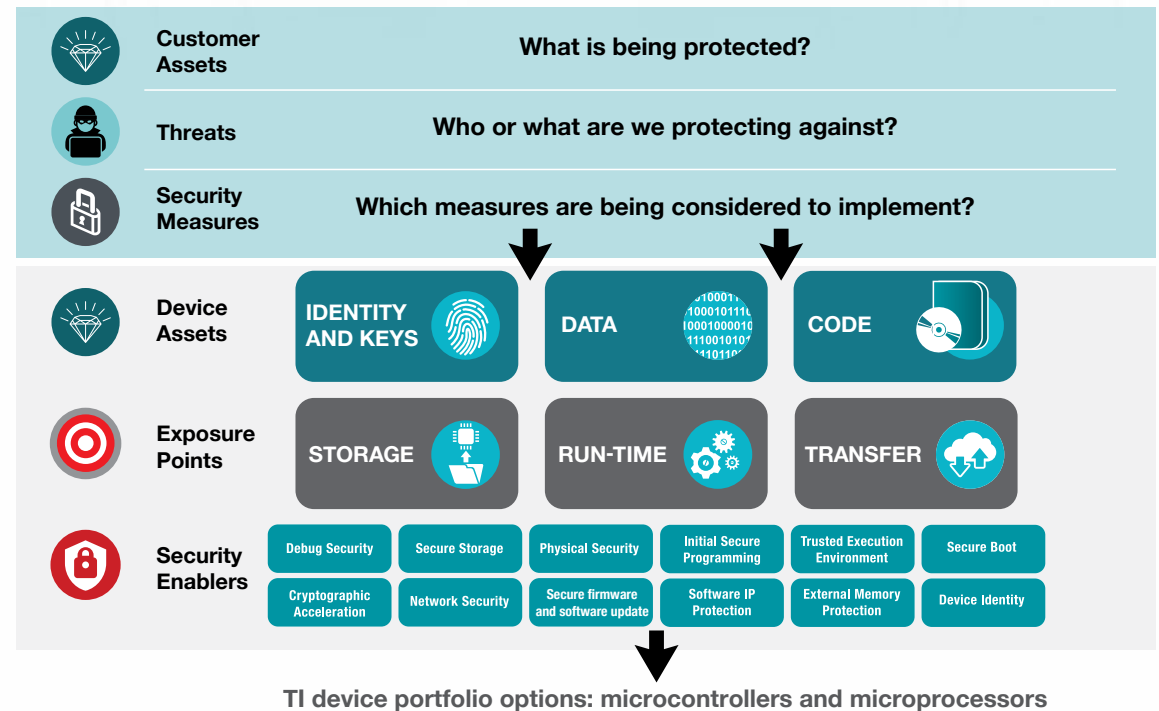

Figure 7 - TI security discovery process summary.

### 3.1. Terminology

It is critical to ensure consistent communications around embedded systems security, especially when there are different definitions for the terms used. Inconsistency – where all parties were sure they understood the security discussions – leads to preventable failures. Therefore, consistent definitions and terminology are required.

**Security:** Using an objective and holistic risk analysis, a designer may assess an asset as secure if the designer has confidence in determining that the value of the protected asset is smaller than the cost of the cheapest attack that compromises this asset

**Asset:** The objects (either physical or logical) that you want to protect. An asset can be firmware that a user loads onto a device, data transmitted over a network or key material stored on a device. The three main categories are:

- **Key and device identity:** Keys used for any cryptographic operations. Device identity can comprise one (or more) unique number(s), key(s) or certificate(s).
- **Data:** Any data that could represent value to an attacker.
- **Code:** Any software code that could represent value to an attacker.

**Security boundaries:** System and SoC boundaries define the limit between an assumed trusted world and a non-trusted world. These boundaries can be static or dynamic:

- **Dynamic:** To receive and apply an over-the-air patch, there needs to be trusted communications channels established between the patch source and destination. This may exist only during the transfer of the patch.
- **Static:** The trusted transmission of instructions from on-chip static random access memory (SRAM) or flash memory to the CPU instruction decoder may be static trusted (always trusted).

**Trusted:** Firm confidence that an entity provides the security goals it claims, and behaves as expected.

**Threat:** Also known as a “threat model.” Threats consist of a person or organization with sufficient motivation, expertise, equipment and time to carry out an attack, as well as the means to gain access. It is the nature of the attack vector that determines the specifics in how much expertise, equipment and time the attack requires.

**Exposure points:** Points in a system where there could be a risk of attack or a way of entry. Also known as an “attack surface.” If a burglar were attacking a house, the exposure point in that case is the door. The three categories in the TI framework are:

- **Storage:** Keys, data or code potentially exposed at rest in external or internal chip memory.
- **Run time:** Keys, data or code potentially exposed during run-time operations of the application.
- **Transfer:** Keys, data or code potentially exposed during transfer from/to a remote location. The transfer could be eavesdropped, intercepted or impersonated.

**Attack vector:** The mechanism used to carry out the attack. If a burglar were attacking a house, the attack vector is the burglar picking the lock of the door.

**Vulnerability:** A weakness in the system that can potentially be exploited. In the burglar analogy, this could be a defect in the lock of the door.

**Exploit:** A weakness of the system that can be exploited.

**Security measures:** Measures aimed at providing the intended protection of certain assets against specific threats.

## 3.2. Detailed security goals and definitions

As we stated earlier, assets are the objects (either physical or logical) that you want to protect. An asset can be firmware that a user loads onto a device, data transmitted over a network or key material stored on a device.

Along with defining the asset, you must also define its security attributes. This is essentially the type of security that could be appropriate to protect an asset. For example, software code may be open and only need protection from modification, or a serial interface may be critical to the system and exposed, so it may need key exchange and encryption.

Some code may be deemed proprietary and require significant efforts to keep it confidential.

**Table 7** lists the most common security attributes/goals.

By narrowing the definition of assets that may need protection and limiting the set of security attributes to only those you strictly need, you can focus your security efforts to those areas where you can gain the most value.

## 3.3. Elements for building an embedded application with security features

Using the security terms defined within this e-book, you can assess your system goals by considering three questions for each identified asset in the system:

- What security attributes does the asset need?
- What threats do I need to protect the asset against?
- What confidence is needed in that protection?

This section gives you a starting point with which to focus your analysis of possible attack vectors, as well as deciding whether your security requirements are too stringent or if a system design effort is required to reduce the overall risk.

Consider a utility metering system (gas, electric, heat) using a global symmetric master key for administration purposes.

The system requires high level of assurance that its key is protected from chip-, board- and network-level threats.

High confidence is required in case a single device is attacked and jeopardizes the entire metering system.

Security Attribute	Definition
Confidentiality	The protection of an asset is not made available or disclosed to unauthorized entities. In this context, entities include both individuals and processes <sup>[1]</sup> . Types of authorized entities include the asset owner, end user, manufacturer or creator, and law enforcement. Vendors may also consider customer code (binary) a confidential asset, as customers control who can read the information.
Access Control	This includes both access authorization and access restriction. It refers to all of the steps taken to selectively authorize and restrict entry, contact or use of assets <sup>[1]</sup> . This applies to all assets from SRAM, ROM and flash memory to control over a peripheral, clock system or simple debugging/JTAG access
Authenticity	These are assets or entities (data, transactions, communications, software or documents – either electronic or physical) confirmed as genuine, authorized to perform a task or used as intended. Authenticity is the validation that all parties involved are who they claim to be and that data has not been modified from the original source by an unauthorized entity.
Availability	Protects assets from unauthorized loss of use (denial-of-service attacks) <sup>[2]</sup> . Loss of use includes many examples, including swamping a communication channel, false revocation of keys, spoofing authentication-failed responses to power-supply brownouts or failed patches, or a false patch to increase the internal revision number significantly in order to saturate (or at least make a legitimate patch fail due to) a revision number out of sequence.
Integrity	Protects assets from unauthorized modification <sup>[2]</sup> . Examples include enabling, disabling or modifying hardware functions such as memory, peripherals, modifying keys, or random number entropy seed. Additional examples include selecting incorrect clock sources, divisors, analog-to-digital converter (ADC) sample rate, programmable gain amplifier (PGA) prescalers, and memory security protection. In software, some other examples comprise of patches for authentication code, security configuration setup code or the creation of a universal master key, deviant interrupt vector tables, setting crypto keys to known values, or adding back doors for remote exploits.

Table 7: Security attributes.



Unfortunately, this might be a costly solution; a better approach would be to have a different asymmetrical key for each metering device.

This approach refocuses the security requirement from a chip, board and network level threat to only a network threat – which happens to be a much cheaper requirement to fulfill in this case. In other words, if you use the same symmetric key in all devices, there is a huge incentive for attackers to retrieve that key. That is why you must consider chip and board threats as well. But if there is a different key (for example, a public key) per chip, then the risk is reduced significantly, as it becomes economically not interesting for attackers to retrieve each and every key.

### 3.4 Security development life cycle

Building embedded applications with security features involves more than performing risk analysis and implementing various security techniques and features. TI, along with other leading technology companies, has recognized the need for a security development life cycle (SDL) [3] [4] [5].

An SDL comprises various practices to help improve the security of a system or product, both at release and during its operational lifetime. Companies have defined their own SDL variants to address their own needs (including using terms other than “SDL”).

Consider SDL practices for all phases of a project, including:

- Concept development/requirements generation
- Architecture
- Design
- Implementation
- Verification/validation
- Maintenance

In addition, an SDL may provide for trainings on security-related topics (such as secure coding techniques, cryptography usage, etc.).

#### Security Assessment

Early in a project, a security assessment of the product should be performed to determine the applicability of the SDL, and what (if any) tailoring of the SDL is needed. This assessment should include looking at the overall system and its individual features to gain an understanding of where there may be risks. Some examples of questions asked during an assessment include:

- Does a system feature store privacy-related data?
- Is the system using a new OS?
- Does the system connect to the internet?
- Does the system have features that should only be available to some stakeholders?

The result of this assessment should be a determination of the applicability of the SDL, and what (if any) tailoring of the SDL.

#### Threat modeling

As explained in [Section 2.1](#), threat modeling is the method for analyzing a system for security threats and determining how to mitigate those threats. As outlined in “Threat Modeling: Designing for Security” by Adam Shostack, threat modeling involves four general steps:

1. Define the system to be protected.
2. Determine what can go wrong.
3. Determine countermeasures for the things that can go wrong.
4. Check your analysis – how good is it?

Step one involves describing the system, often using data-flow diagrams and/or control-flow diagrams. Various techniques can assist a development team during step two to determine what can go wrong (how a malicious actor can attack the system). Step three entails generating a collection of attack possibilities, prioritizing them and putting countermeasures in place. Step three may also result in features changing or being dropped altogether from the product if the security risks are deemed too severe (often called “attack surface reduction”). Finally, step four provides a valuable review to look for things missed in earlier steps.

Threat modeling continues to evolve. Table 8 provides a short overview of several threat-modeling techniques, along with resources for additional reading.

You may want to evaluate the current state of each technique in relation to the four threat-modeling steps outlined above and in relation to currently available tool support.

**Table 8** isn't intended to be an exhaustive list of all techniques available today, nor is it ranked in any particular order.

### Reviews and testing

Many security vulnerabilities are the result of low-level design mistakes. Issues such as buffer overflows and use-after-free bugs are not apparent at an architectural level of abstraction<sup>[14]</sup>. Design reviews provide an opportunity to examine the design for both low-level defects and adherence to security best practices. For example, reviews can check for the use of banned functions, old tools or libraries, known unsafe practices for the given implementation language and more.

Developing and using checklists can help the reviews. Update the checklists as new vulnerability reports offer lessons learned. Checklists alone are not sufficient for developing a secure system, however.

Name	Description	Further Reading
STRIDE	Developed by Microsoft, STRIDE is a mnemonic to assist an analysis team in determining what can go wrong. Each letter in the word STRIDE represents a different threat category: spoofing, tampering, repudiation, information disclosure, denial of service and elevation of privilege.	"Threat Modeling: Designing for Security" by Adam Shostack <sup>[5]</sup>
Attack Trees	Attack trees use the concept of a tree to think through attacks against a system. The root of a given tree represents the attacker's goal, while the leaf nodes represent different ways the attacker may accomplish that goal. Mitigations are designed to reduce the risk of each path through the tree to the root node.	"Attack Trees" by Bruce Schneier <sup>[6]</sup>
PASTA	The Process for Attack Simulation and Threat Analysis (PASTA) provides a seven-step process to threat modeling: define business objectives, define the technical scope, decompose the application/system, analyze the threats, analyze the system for vulnerabilities and weaknesses, enumerate attacks, and analyze risk/impact.	"Risk Centric Threat Modeling: Process for Attack Simulation and Threat Analysis" by Tony UcedaVélez and Moarco M. Morana <sup>[7]</sup>
STAMP and STPA	System-Theoretic Accident Model and Process (STAMP) is an accident model, whereas Systems-Theoretic Process Analysis (STPA) is a hazard analysis method. Both were developed at MIT for safety applications. However, STPA's systems-based approach has allowed researchers and practitioners to apply it beyond safety applications and into security.	"Engineering a Safer World: Systems Thinking Applied to Safety" by Nancy Leveson <sup>[8]</sup>  MIT's Partnership for a Systems Approach to Safety (PSAS) website <sup>[9]</sup>  "STPA-SafeSec: Safety and security analysis for cyber-physical systems" <sup>[10]</sup>
Intrusion Kill Chain	Intrusion kill chains look at the operation of a system instead of its design. Splitting attacks into phases, the system is analyzed to find mitigations to stop (kill) the attack (intrusion) at each phase.	"Intelligence-Driven Computer Network Defense Informed by Analysis of Adversary Campaigns and Intrusion Kill Chains" <sup>[11]</sup>  "The Industrial Control System Cyber Kill Chain" <sup>[12]</sup>
FMEA	FMEA stands for failure mode and effect analysis and is not specifically a threat-modeling tool. However, some groups have attempted to apply it to threat modeling. The FMEA focus on reliability must be reworked when used for threat modeling, since security involves much more than reliability.	"Security Application of Failure Mode and Effect Analysis (FMEA)" <sup>[13]</sup>

Table 8: Threat modeling techniques.

Verify the requirements resulting from a security assessment and threat modeling via testing. While classic functional testing techniques often apply, additional testing techniques available for vulnerability testing include:

- **Fuzz testing:** Random inputs attempt to crash the target, which an attacker can often use as a starting point for a more useful attack.
- **Static analysis:** Using security-focused rules.
- **Vulnerability scanning:** Using a tool to scan a system for known vulnerabilities, such as looking for known vulnerabilities in a Secure Sockets Layer (SSL) library.

In addition to individual testing techniques, another common testing methodology is called penetration testing (also known as pen testing). Pen testing focuses on real-world scenarios and finds ways that an attacker can circumvent

a system's security. The effectiveness of pen testing is often correlated to the experience of the team running the tests. You can hire a company to perform pen testing on a targeted product, but any selection process for a company like this should include an evaluation of its overall experience level, as well as its experience with the kind of product being tested.

### **Response planning**

Unfortunately, mistakes will be made during a system's development. While following a solid SDL will likely reduce the number of vulnerabilities in a system, it is unlikely to remove all of them. In addition, new attack techniques are developed regularly, which expose vulnerabilities that a development team could not have foreseen.

When exposure points are exploited in the field, teams may need to move quickly to resolve them. Planning ahead will allow development teams to execute with precision and speed. A response plan should generally include the following steps:

- Identify individuals or teams responsible for executing the response plan.
- Identify or create a path to report vulnerabilities.
- Establish a process to triage the reported vulnerabilities.
- Establish a process to analyze, close and test an exposure point.
- Establish a process to release the fixed device and security bulletins and manage customer relationships.
- Update training and testing to catch similar issues in the future.

# 4

## Chapter 4: Threats and adversaries: The main exposure points and attack types

As depicted in **figure 1**, the main assets in a system that may need protection can be categorized as data, code, device identities and keys. The exposure points in a system increase the vulnerability of these assets during system operation and require different and appropriate security features. Exposure points in a system can be broadly categorized as storage, run-time and transfer operations. Based on the assets needing protection and the exposure points, consider the appropriate security features to design protection.

From a system-access perspective, an attacker poses three main types of threats: to the network (remote), to the board (close proximity) and to the chip (see **table 1**).

### 4.1. Network threats

With the massive growth of connected devices, network attacks are becoming more common. This is attributed to a number of aspects related to the fundamental nature of communication networks. A network topology (like that

shown in **figure 8**) provides an exponentially growing number of attack paths and a growing potential to identify an exposure point through which an attacker can reach the target asset. Furthermore, an attack from the network is less obvious, thus providing the attacker some level of anonymity over a physical attack.

The structured nature of security protocol stacks (see **figure 9**) increases the opportunity for more attacks due to the different layers of implementation, as well as the cross-layer glue logic. These layers are in many cases less well-defined and more prone to implementation faults.

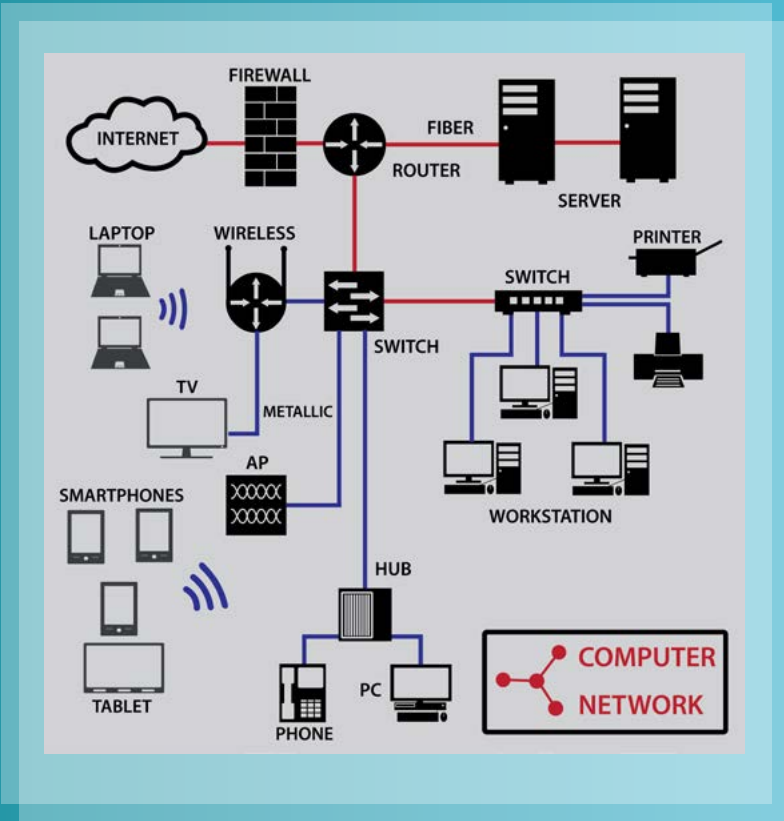

Figure 8 - Typical network topology.

Network attacks may take many different shapes and forms. Some of the most common types include:

- **Tapping/eavesdropping.** This refers to the act of sniffing the network at various points with tools that can eavesdrop, intercept, replay and impersonate anything transmitted over the network. In general, measures that can achieve confidentiality, integrity and authenticity of the transmitted assets or commands are necessary.

- **Man-in-the-middle (MITM).** This is an attack in which the attacker – without being detected – relays and possibly alters the communication between two parties who believe they are communicating directly with each other. It is usually performed to gain access to an asset. For example, an attacker within range of an unencrypted Wi-Fi access point can insert himself as an MITM.

- **Denial of service (DoS) and distributed DoS (DDoS).** This attack blocks the availability and accessibility of a resource. A distributed DoS attack is a synchronized attack originating from multiple sources, thus making it harder to block.
- **Malware.** Malware is malicious software successfully delivered to a point with network access. Once in place, the software may potentially attack that point either passively or actively. When performed passively, malware monitors activity that goes through that point; when active, it alters its behavior.

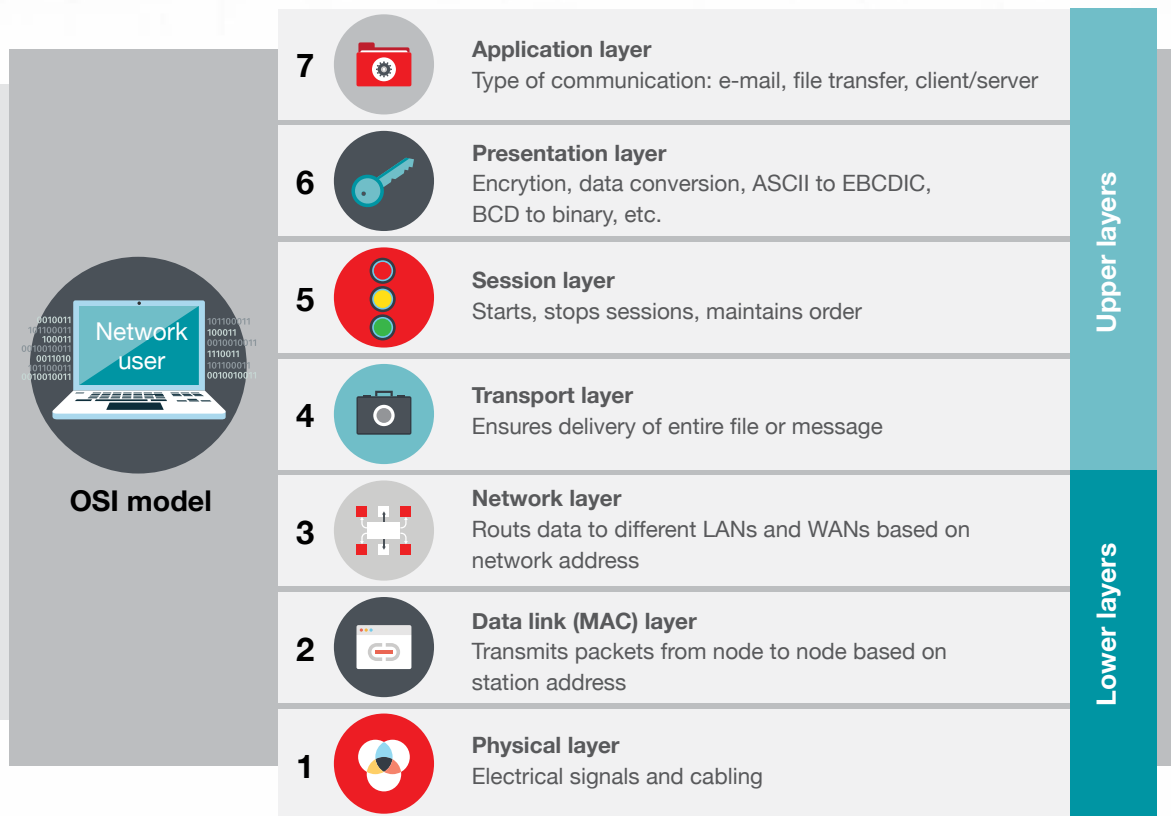

Figure 9 - Open systems interconnection (OSI) model for a network protocol stack.

## 4.2. Board threats

Board attacks are broadly categorized as noninvasive or invasive, depending on whether physical intrusion or damage to the product at a system level was involved. Noninvasive board attacks observe or manipulate the device without any physical harm or tampering. These are the three most common types:

- Side-channel attacks observe device behavior while it performs cryptographic or secure operations (execution time, power consumption or behavior in the presence of faults) to retrieve keys or passwords. Common side-channel attacks include:
  - Timing analysis
  - Electromagnetic analysis (EMA)
  - Simple power analysis (SPA)
  - Differential power analysis (DPA)

- Fault-injection attacks alter environmental and operating conditions to cause the device to malfunction in a way that compromises security (such as skipping a critical CPU instruction or erasing bits that defeat device debugging locks). Common methods include:
  - Altering voltages to introduce glitches.
  - Varying the supply voltage beyond the operating limits.
  - Altering the device temperature below or above its operating limits.
  - Altering clocking to damage external crystals.
  - Sending too-short clock pulses.
- Software attacks launch through communication interfaces with the device. Device debugging (JTAG) or other programming interfaces are the most common targets, like bootloaders, vendor-proprietary interfaces and protocols, and serial data communication interfaces like I<sup>2</sup>C, UART, SPI, QSPI and EMIF.

Invasive board attacks involve physical intrusion at a product or system level. This includes intrusion of product enclosures or tamper-protected enclosures (like PCB tamper mesh).

### 4.3. Chip threats

Chip threats enable unauthorized access beyond just the board signals, reaching into the chip's internal signals in an effort to retrieve on-chip nonvolatile memory. The information gained can be the end goal itself. For instance, if an attacker obtains user code stored in on-chip flash and understands the application board schematics, they can clone and sell the application itself on the counterfeit market without the laborious and expensive R&D work. Alternatively, searching the same flash image for run-time weaknesses or encryption keys reveals vulnerability to a network attack. Once discovered, this network attack can be launched remotely to cause harm or steal further secrets.

Decapsulating the package, observing photons emitted by transistors using emission microscopy (EMMI), manipulating security bits with a laser, cutting security signals with a focused ion beam (FIB), nanoprobng data lines, imaging the back side of flash contents with a scanning electron microscope (SEM), and deprocessing and reverse-engineering the device circuit layers are just a few examples of chip threats. The level of special knowledge, motivation, skill and cost required to carry out chip attacks varies, but in general is much greater than electrical attacks to the board.

### 4.4. Consequences of poor security

To provide some real-world context to the abstract question of why security matters, it's important to consider and discuss five situations where security mechanisms have failed.

- **Using a common password for a large number of devices.** It is unfortunately all-too-common in the design of a system that convenience takes precedence over security. From a consumer standpoint, it is not uncommon to see people using the same password or PIN across various accounts, devices and websites. Cybersecurity practitioners make the same mistake when it comes time to design a key management system and infrastructure. Developers often opt for an approach based on a common key rather than using a different key per system, device or endpoint because it is more convenient and cheaper. Such a mistake has led to some rather large-scale attacks. For example, well-publicized internet DDoS attacks in 2016 came as a result of consistent default passwords on some IoT embedded systems. Because system owners didn't modify the default password before adding it to the network, hundreds of thousands of devices were quickly taken over and made part of a malicious botnet <sup>[15]</sup>.

- **Using a proprietary algorithm and security by obscurity.** A second example is using proprietary algorithms for cryptography. Standard, industry-accepted algorithms have received the proper attention, testing and study before becoming a standard. The entire cryptographic community constantly attacks and reviews these standards to ensure that they continue to withstand scrutiny. In many instances, when proprietary algorithms are finally publicly known (due to reverse-engineering or another source of leakage), they are easily and very quickly undermined and broken by the same cryptographic community. A few more notorious failures from the embedded systems space are Keeloq and HiTag2 <sup>[16]</sup> <sup>[17]</sup>.

According to Kerckhoff's principle, one of the fundamental principles in security is that a cryptosystem should be secure even if everything about the system (except the key) is public knowledge. Cryptographer and engineer Claude Shannon once said, "One ought to design systems under the assumption that the enemy will immediately gain full familiarity with them." But just because "one ought to design" a secure system with that mindset does not mean that system designers should help attackers gain that familiarity. Keeping implementation details secret can buy you quite a lot

of time – maybe even years, but it should never be the main pillar of security.

- **In-field firmware updates gone wrong.** In-field firmware updates have enabled new firmware images to be downloaded and installed into devices already deployed in the field, providing an effective way for manufacturers to offer service and support for their products after leaving the factory. However, in the absence of proper security measures, this feature may be misused. The consequences of a successful exploitation can be disastrous, ranging from a loss of IP and product cloning all the way to attackers successfully completing a takeover of the deployed systems.

For example, if a medicine pump does not verify the authenticity of new firmware images, a successful exploitation of the firmware update mechanism could potentially allow attackers to change or control the dosage delivered to a patient and alter the pump's display screen to indicate that a dosage was delivered<sup>[18]</sup>. In this scenario, failure to secure the device's firmware upgrade process could contribute to the device not functioning as intended.

- **Interconnected system complexity leads to failure.** Large, complex and interconnected systems can make it extremely difficult to discover and close security gaps. This is becoming more common as engineers connect

more embedded systems to the internet each day.

Consider the case of an internet-connected vehicle. Automotive manufacturers like this idea because it allows them to remotely collect diagnostic and usage information; meanwhile, it can also be another potential revenue stream, allowing a service like in-vehicle Wi-Fi hotspots. New car buyers are attracted to these types of services since they enable features like automatic crash notification to emergency services or remote unlock in case of emergencies.

Beyond convenience, that connectivity also becomes an avenue for attackers to remotely get into vehicle systems. Recently, unauthorized users remotely accessed a vehicle connected to a cellular data network. At first, only noncritical systems like the radio, navigation and climate control were breached; but it was later discovered that those systems shared a connection to the vehicle's critical safety bus, where things like brakes, steering and the engine were connected. By simply bridging from the internet to the car radio and finally the safety bus of the vehicle, the attackers compromised its systems<sup>[17]</sup>. Those compromised systems could potentially cause system malfunctions in the vehicle that could have real-world consequences.

- **Secure programming failures.** It's important to understand that attackers don't create security holes; they simply exploit them. Security gaps exist due to programming errors and coding flaws. In the most common embedded system programming languages, one of the most repeated mistakes is a failure to do proper bounds checking on memory accesses. Depending on whether memory is being written or read, the outcome of improper bounds checking will differ. Writing to memory can lead to buffer overflows. First described in the mid-1990s, stack-based buffer overflow attacks are probably still the most common way for attackers to exploit a targeted system. Overflowing a buffer on a stack can allow attackers to overwrite return addresses or inject new code. Depending on the rights of the process whose stack has been corrupted, the system can be completely under the attacker's control. If a vulnerable program is one that can receive input over a network connection, there is real potential for remote system compromises. This was the case for the famous computer worm Conficker, which spread rapidly by exploiting a buffer overflow bug in the Windows Remote Procedure Call service, ultimately infecting millions of computers and used as an attack vector for installing malware. Reading memory can cause information leakage. When reading more data than should be allowed, information

that would normally remain private can potentially leak outside the system. As in the case with writing, network-related code with this type of bug can leak information to remote systems. Such was the case with the OpenSSL Heartbleed vulnerability in 2014. Due to improper bounds checking with a certain protocol feature, private program data (a server or other network daemon that relied on OpenSSL) would be returned to a remote client. This could compromise critical information such as the server's private keys, and ultimately all communication with the server.

This is just a brief list of programming-based errors; there are many more with security implications. The fundamental point is that coding errors can have real-world consequences if exploited.

#### **4.5. Leveraging industry standards and specifications for security**

In today's embedded world, the need to provide security in a system is unquestionable; however, this poses many challenges for designers. First and foremost, you must define adequate security requirements at the outset to build a system with security in mind, and invest a reasonable amount of effort and confidence into reducing the amount of exposure points in the system.

Across the semiconductor industry and academic world, various efforts on two complementary fronts are taking

place: First, research on exposure points for existing systems and cryptographic protocols, and second, defining effective measures to secure systems against such vulnerabilities. Standards, specifications, guidelines and certifications exist to help you maintain confidence that your systems and designs have achieved their defined security goals and requirements.

Before going into more details about some of the available security standards and schemes, it's important to clarify the relationship between the process of certification and the standards (document established by central agencies such as the NIST, BSI, ANSSI). The process of certification or compliance is typically known as a certification scheme, whereas this process uses a set of industry standards or specifications. As a result, we can consider the standard as a part of a certification or compliance scheme.

#### **The Common Criteria for Information Technology**

**Security Evaluation** (called Common Criteria or CC) is an international standard (International Organization for Standardization [ISO]/International Electrotechnical Commission [IEC] 15408) for computer security certification [2]. It provides a rigorous, standard and repeatable process to specify, implement and evaluate a computer security product. The process usually starts with a protection profile that defines the threats, assets and objectives.



The level of assurance can be different for various products and markets. For example, personal computers are typically at evaluation assurance level (EAL) 2, trusted platform model (TPM) devices at EAL 4+, and smart cards or e-passports at EAL 5+. One of the main steps of this process is a vulnerability assessment (AVA\_VAN level), which determines the exploitability of flaws or weaknesses for the target of evaluation (TOE) within the operational environment. The process also defines requirements for assurance through the adoption of a well-defined life-cycle model (configuration management, documentation, site security, fabrication, etc.).

#### **Payment Card Industry-PIN Transaction Security**

(PCI-PTS) is payment security certification applicable to PIN-based credit cards. It is managed by the PCI Council, which is funded by financial institutions like MasterCard, Visa, JCB and Discover. The specification is designed to streamline security standards and the development of secure devices for payment by establishing common requirements, resulting in more consistent security measures and cost-effective market deployments. Common requirements benefit everyone in the financial payment sector and improve overall security for customer-entered data by removing conflicting requirements. Each

PCI-PTS-certified device has to pass a PCI-accredited lab audit. Formal reports quantify the security of a device against the PCI-PTS specification.

The U.S. government's **Federal Information Processing Standard (FIPS) Publication 140-2** is a computer security standard used to accredit both hardware and software cryptographic modules and protocols.

The publication classifies system tampering starting from simple evidence (level two, package of a chip) to robust detection (high probability) and resistance (levels three and four). The level three and four usually require a specialized module to detect and respond to a tamper attempt.

This standard focuses on the correct implementation of cryptographic algorithms, which includes health tests performed on the implementations of the cryptographic algorithms to verify proper functionality and the cryptographic key-management system. An independent laboratory contracted by the application manufacturer performs validation testing and issues a report.

The **ISO/IEC 27001** standard is used for the certification of information security. It can certify the appropriate level of policies and procedures in the organization (i.e. the manufacturer) for developing, producing, building or

operating smart-grid systems and components. IEC/ISO 27019:2013 provides guiding principles (based on ISO/IEC 27002) for information security management within the energy utility industry; however, this standard only provides guiding principles, not certifiable requirements.

Outside the well-established standards bodies, various other standards and specifications exist.

The **Secure Hardware Extension** (SHE) is a hardware and software specification developed by ESCRYPT, along with Audi and BMW, as an on-chip extension within MCUs. It creates a secure zone for automotive applications and defines cryptographic services through a set of functions and APIs to the application layer in an authentic software environment. The SHE specification also defines a hardware secure zone for isolating cryptographic secret keys from the rest of a system.

The three major blocks which make up a secure hardware zone:

- A storage area for protecting keys and additional corresponding information.
- An AES engine for providing cryptographic services.
- Control logic for interfacing to the MCU's core.

## E-Safety Vehicle Intrusion Protected Applications

(EVITA) is a hardware and software specification that provides guidelines for a secure on-board architecture, in addition to protocol and prototype demonstrations for automotive applications. It is sponsored by the European Commission and developed by a consortium consisting of automotive manufacturers and suppliers. The approach is based on hardware and software co-design – a design for hardware security modules (HSMs) and APIs that interact with the HSM.

The general structure of an HSM consists of four blocks: secure storage, crypto hardware acceleration, secure CPU and a hardware interface to the rest of the system.

The EVITA specification also defines three HSM architectures for different security requirements and cost constraints: EVITA Full, EVITA Medium and EVITA Light.

These vary in terms of the capability they provide on the four blocks.

The HSM architecture can be integrated in three different variants:

- **HSM in a separate chip to the CPU.** This is in general considered less secure than a single-chip solution and more expensive. It is less secure because an attacker can eavesdrop on the wiring between the CPU and HSM to get information about secret values, or ask the HSM to sign data not generated by the CPU.
- **HSM in the same chip as the CPU, but with a state machine.** This solution is usually considered more secure than an external chip and could be even more economical, but it is not flexible enough to reflect the future needs of security, as you cannot integrate new cryptographic algorithms. This type of design may be appropriate for very high security applications with very short lifetimes.
- **HSM in the same chip as the CPU, but with a programmable secure core.** This solution is usually considered the most secure and flexible. This would also be of benefit for several other applications outside the automotive industry due to its flexible and programmable architecture.

Application designers can get a third-party audit with an accredited test house or laboratory to perform readiness assessments of their security solution and identify any areas of noncompliance before the actual certification testing. This audit process typically involves four steps:

- A consultation to help assess how the certification requirements apply to the application.
- A comprehensive evaluation of the solution to verify that it complies with the requirements.
- A compliance report that documents testing procedures, assessments, any risk and necessary actions to mitigate those risks.
- An evaluation of changes to an approved solution to verify continued compliance with the requirements.

The third-party audit process helps define and design application security by minimizing the risk of noncompliance to the certification standard. This process is especially invaluable if you are new to the certification process and helps speed up the whole certification and approval process. TI has over the years gotten several products audited and generally makes reports available under nondisclosure agreements (NDAs).

## 5.1. A long history

TI has a long history in developing devices with security enablers and technologies that assist designers in meeting industry or customer security requirements that are pertinent to their application. For instance, TI was one of the first semiconductor companies to implement, develop and deploy full ARM® TrustZone extensions for applications in the mobile market (M-Shield™ security hardware and software) and has continued over the years to provide these types of security features in its embedded processors and analog products.

With the growing market demand for wireless connectivity, TI has developed a broad portfolio of processors, secure processors (ePOS), wireless connectivity microcontrollers (SimpleLink MCUs) and wireless network processors for the embedded world. Acknowledging the importance of

security but realizing the complexity of introducing state-of-the-art security capabilities into a product, TI prioritized devices that address these aspects so you have the power to address security challenges with ease.

The SimpleLink™ Wi-Fi® device family is just one result of this vision; it is available in two versions, either as a catalog MCU with a pre-integrated Wi-Fi networking subsystem (the SimpleLink CC3220 wireless MCU) or as a stand-alone Wi-Fi-networking companion device (the SimpleLink CC3120 network processor). The SimpleLink Wi-Fi portfolio takes a holistic view of security challenges, encompassing a range of features to address a issues including secure communication, secure storage, key management, identity aspects, security during development and security during production. TI designed these capabilities to be seamless to users and implicit to the product architecture. Ease

of implementation through straightforward APIs puts the power of security in your hands and helps you work toward minimizing possible misuse of your products.

Throughout the decades, TI has successfully delivered devices with security features to a wide range of applications and markets that require security, including automotive key fobs, ink cartridge authentication, battery authentication, medical devices\* (blood glucose meters [BGMs]), cable authentication and ePOS.

Through its vast network of engineers and market expertise, TI has developed a broad portfolio of security features to assist you in designing for and implementing security to meet your desired objectives.

*\*TI products are not authorized for use in life-critical medical equipment unless authorized officers of the parties have executed a special contract specifically governing such use. See TI's terms of sale at [www.ti.com](http://www.ti.com).*

**M-Shield™ Mobile Security  
Technology: making wireless secure**



TI is delivering hundreds of security features integrated across its broad embedded processing portfolio to enable developers to meet their products' security goals. TI's large embedded processing portfolio ranges from microprocessors to microcontrollers including the SimpleLink™ MCU platform enabling developers to reuse 100 percent of their code across the portfolio of MCUs supporting a wide range of connectivity standards and technologies including RS-485, *Bluetooth*® low energy, Wi-Fi®, Sub-1 GHz, 6LoWPAN, zigbee®, Ethernet, Thread, RF4CE and proprietary RF. The table below features some key products of the embedded processing portfolio and highlights the corresponding supported security enablers and features.

	Portfolio: Learn About the Security Offering	TI Security Enabler (Device Feature Example)
Microcontrollers	<a href="#">MSP430™ ultra-low power MCUs</a>	<ul style="list-style-type: none"> <li>• Device identity (unique ID)</li> <li>• Debug security (JTAG lock w/ password)</li> <li>• Cryptographic acceleration (AES 128/192/256)</li> <li>• Software IP protection (Debug lock-out, IP encapsulation)</li> </ul>
	<a href="#">C2000™ real-time control MCUs</a>	<ul style="list-style-type: none"> <li>• Secure boot (MAC-based)</li> <li>• Device identity (unique ID)</li> <li>• Debug security (JTAG lock with password)</li> <li>• Cryptographic acceleration (AES 128/192/256)</li> <li>• Software IP protection (IP Protected zones)</li> </ul>
	<a href="#">SimpleLink™ MSP432™ MCUs</a>	<ul style="list-style-type: none"> <li>• Device identity (unique ID)</li> <li>• Debug security (JTAG lock w/ password, factory reset configuration)</li> <li>• Cryptographic acceleration (AES 128/192/256)</li> <li>• Software IP protection (IP Protected zones)</li> <li>• Secure firmware &amp; software update (AES-encrypted firmware update/ password authentication )</li> </ul>
Wireless Microcontrollers	<a href="#">SimpleLink Sub-1 GHz Wireless MCUs</a>	<ul style="list-style-type: none"> <li>• Device identity (Unique ID)</li> <li>• Debug security/ Software IP protection (JTAG lock)</li> <li>• Cryptographic acceleration (AES 128, AES-CCM, TRNG)</li> </ul>
	<a href="#">SimpleLink Bluetooth® low energy Wireless MCUs</a>	<ul style="list-style-type: none"> <li>• Device identity (Unique ID)</li> <li>• Debug security/ Software IP protection (JTAG lock)</li> <li>• Cryptographic acceleration (AES 128, AES-CCM, TRNG)</li> </ul>
	<a href="#">SimpleLink Wi-Fi® Wireless MCUs</a>	<ul style="list-style-type: none"> <li>• Secure boot (authenticated boot, standard secure, root-of-trust public key)</li> <li>• Device identity (unique private key per device)</li> <li>• Debug security (JTAG lock)</li> <li>• Cryptographic acceleration (AES 128/192/256, DES/3DES, SHA 1/2)</li> <li>• Networking security (WPA2, TLS)</li> <li>• Secure storage (secure storage)</li> <li>• Software IP protection (cloning protection)</li> <li>• Initial secure programming (encrypted firmware flow for manufacturing)</li> <li>• Secure firmware &amp; software update (file system security, software tamper protection)</li> </ul>
Processors	<a href="#">Sitara™ Processors</a>	<ul style="list-style-type: none"> <li>• Secure boot (authenticated boot, standard secure, root-of-trust public key)</li> <li>• Device identity (unique ID)</li> <li>• Debug security (JTAG lock)</li> <li>• Cryptographic acceleration (AES 128/92/256, DES/3DES, RSA, ECC, SHA 1/2, TRNG)</li> <li>• External memory protection (encrypted execute-in-place with QuadSPI)</li> <li>• Trusted execution environment (TEE)</li> <li>• Secure storage (TEE)</li> <li>• Software IP protection (Debug lock-out)</li> <li>• Initial secure programming (secure boot, secure flashing)</li> <li>• Physical security (anti-tamper module)</li> </ul>
	<a href="#">Automotive Processors</a>	<ul style="list-style-type: none"> <li>• Secure boot (root-of-trust public key)</li> <li>• Device identity (unique ID)</li> <li>• Debug security (JTAG lock w/ password)</li> <li>• Cryptographic acceleration (AES 128/92/256, DES/3DES, SHA 1/2, TRNG)</li> <li>• External memory protection (firewalls)</li> <li>• Secure storage (secure ROM APIs, anti-cloning)</li> <li>• Software IP protection (Debug lock-out)</li> </ul>

## 7 Conclusion

This e-book provided a glimpse into how TI can help designers achieve their security goals by analyzing a targeted application and holistically considering its security. We covered the main steps of the security implementation cycle: the identification of the security goals, risks and measures. Then we provided a way to derive from the security measures what security enablers can help you achieve your security goals. Finally, we provided more leads and guidance for identifying security goals and risks.

Security is a matter that you must consider in the early phases of a project, not as an afterthought. Carefully evaluate the risks of each decision in order to weigh it correctly and choose the necessary measures appropriately. A risk analysis is the cornerstone of any application requiring some level of security and it is really in your hands. For more information, see [ti.com/security](https://ti.com/security).



# 8 Appendix

## Bibliography

- [1] "ISO 27k security certification," [Online]. Available: <http://www.praxiom.com/iso-27001-definitions.htm>.
- [2] "Common Criteria for Information Technology Security Evaluation," 2012. [Online]. Available: <https://www.commoncriteriaportal.org/files/ccfiles/CCPART1V3.1R4.pdf>.
- [3] Microsoft, "Security Development Lifecycle," [Online]. Available: <https://www.microsoft.com/en-us/sdl/>. [Accessed August 26, 2016].
- [4] M. Howard and S. Lipner, "The Security Development Lifecycle: SDL: A Process for Developing Demonstrably More Secure Software," Redmond, Washington: Microsoft Press, 2009.
- [5] H. Khattri, N.K.V. Mangipudi and S. Mandujano, "HSDL: A Security Development Lifecycle for Hardware Technologies," in Institute of Electrical and Electronic Engineers (IEEE) HOST, San Francisco, California, 2012.
- [6] B. Schneier, "Attack Trees," December 1999. [Online]. Available: [https://www.schneier.com/academic/archives/1999/12/attack\\_trees.html](https://www.schneier.com/academic/archives/1999/12/attack_trees.html). [Accessed Oct. 6, 2016].
- [7] T. UcedaVélez and M.M. Morana, "Risk Centric Threat Modeling: Process for Attack Simulation and Threat Analysis," Wiley, 2015.
- [8] N. Leveson, "Engineering a Safer World: Systems Thinking Applied to Safety," The MIT Press, 2011.
- [9] Massachusetts Institute of Technology (MIT), "MIT Partnership for a Systems Approach to Safety (PSAS)," [Online]. Available: <http://psas.scripts.mit.edu/home/>. [Accessed Sept. 2, 2016].
- [10] I. Friedberg, K. McLaughlin, P. Smith, D. Lavery and S. Sezer, "STPA-SafeSec: Safety and security analysis for cyber-physical systems," *Journal of Information Security and Applications*, vol. 29, 2016.
- [11] E.M. Hutchins, M.J. Cloppert and R.M. Amin, "Intelligence-Driven Computer Network Defense Informed by Analysis of Adversary Campaigns and Intrusion Kill Chains," Lockheed Martin Corporation, 2011.
- [12] M.J. Assante and R.M. Lee, "The Industrial Control System Cyber Kill Chain," SANS Institute, 2015.
- [13] C. Schmittner, T. Gruber, P. Puschner and E. Schoitsch, "Security Application of Failure Mode and Effect Analysis (FMEA)," *Computer Safety, Reliability, and Security*, vol. 8666, pp. 310-325, 2014.
- [14] "Common Weaknesses Enumeration," [Online]. Available: <https://cwe.mitre.org/data/definitions/416.html>.
- [15] Z. Wikholm, "When Vulnerabilities Travel Downstream," Oct. 7, 2016. [Online]. Available: <https://www.flashpoint-intel.com/when-vulnerabilities-travel-downstream/>.
- [16] E. Biham, O. Dunkelman, S. Indestegee, N. Keller and B. Preneel, "How to Steal Cars – A Practical Attack on KeeLoq," 2007. [Online]. Available: <https://www.cosic.esat.kuleuven.be/keeloq/keeloq-rump.pdf>.
- [17] A. Greenberg, "A New Wireless Hack Can Unlock 100 Million Volkswagens," August 10, 2016. [Online]. Available: <https://www.wired.com/2016/08/oh-good-new-hack-can-unlock-100-million-volkswagens/>.
- [18] K. Zetter, "Hacker Can Send Fatal Dose to Hospital Drug Pumps." June 8, 2015. [Online]. Available: <http://www.wired.com/2015/06/hackers-can-send-fatal-doses-hospital-drug-pumps>.
- [19] A. Shostack, "Threat Modeling: Designing for Security," Wiley, 2014.
- [20] Open Web Application Security Project (OWASP), "Open Web Application Security Project," OWASP, [Online]. Available: <https://www.owasp.org>. [Accessed August 26, 2016].
- [21] OWASP, "OpenSamm," OWASP, [Online]. Available: <http://www.opensamm.org/>. [Accessed August 23, 2016].

## IMPORTANT NOTICE AND DISCLAIMER

TI PROVIDES TECHNICAL AND RELIABILITY DATA (INCLUDING DATASHEETS), DESIGN RESOURCES (INCLUDING REFERENCE DESIGNS), APPLICATION OR OTHER DESIGN ADVICE, WEB TOOLS, SAFETY INFORMATION, AND OTHER RESOURCES "AS IS" AND WITH ALL FAULTS, AND DISCLAIMS ALL WARRANTIES, EXPRESS AND IMPLIED, INCLUDING WITHOUT LIMITATION ANY IMPLIED WARRANTIES OF MERCHANTABILITY, FITNESS FOR A PARTICULAR PURPOSE OR NON-INFRINGEMENT OF THIRD PARTY INTELLECTUAL PROPERTY RIGHTS.

These resources are intended for skilled developers designing with TI products. You are solely responsible for (1) selecting the appropriate TI products for your application, (2) designing, validating and testing your application, and (3) ensuring your application meets applicable standards, and any other safety, security, or other requirements. These resources are subject to change without notice. TI grants you permission to use these resources only for development of an application that uses the TI products described in the resource. Other reproduction and display of these resources is prohibited. No license is granted to any other TI intellectual property right or to any third party intellectual property right. TI disclaims responsibility for, and you will fully indemnify TI and its representatives against, any claims, damages, costs, losses, and liabilities arising out of your use of these resources.

TI's products are provided subject to TI's Terms of Sale ([www.ti.com/legal/termsofsale.html](http://www.ti.com/legal/termsofsale.html)) or other applicable terms available either on [ti.com](http://ti.com) or provided in conjunction with such TI products. TI's provision of these resources does not expand or otherwise alter TI's applicable warranties or warranty disclaimers for TI products.

Mailing Address: Texas Instruments, Post Office Box 655303, Dallas, Texas 75265  
Copyright © 2020, Texas Instruments Incorporated