



Description

The AM263x Control Card Evaluation Module (EVM) is an evaluation and development board for the Texas Instruments Sitara™ AM263x series of microcontrollers (MCUs). This EVM provides an easy way to start developing on the AM263x MCUs with on-board emulation for programming and debugging as well as buttons and LEDs for a simple user interface. This version of the AM263x Control Card (TMDSCNCD263-PMIC) has all of the qualities of the original AM263x Control Card (TMDSCNCD263) while also incorporating a PMIC power solution and replacing two of the Industrial Ethernet PHYs plus RJ45 connectors with Automotive Ethernet PHYs plus MATEnet connectors. The control card also enables header pin access to key signals through the use of a high speed edge connector (HSEC) baseboard docking station for rapid prototyping.

Features

- **Integrated power and safety monitoring solution that is consistent with the ISO26262 ASIL-D specification**
 - **Multirail Power Supply designed for Safety-Relevant Applications**
 - **Automotive, dual-channel voltage supervisor with very-high accuracy**
- **Two MATEnet connectors with on-board Automotive Ethernet PHYs**
- One RJ45 ethernet port with on-board Industrial Ethernet PHY
- PCB dimensions: 131.15 mm width by 92.81 mm length + 6.17 mm length of HSEC interface
- Powered through 5 V, 3 A USB type-C input
- On-board XDS110 debug probe
- 180 pin HSEC interface for rapid prototyping
- Three push buttons:
 - PORz
 - User interrupt
 - RESETz
- LEDs for:
 - Power status
 - User testing
 - Ethernet connection
 - I2C driven array
- CAN connectivity with on-board CAN transceiver
- LIN connectivity with on-board LIN transceiver
- Dedicated FSI connector
- TI Test Automation Header
- MMC interface to micro SD card connector
- On-board memory
 - 128 MB QSPI Flash
 - 1 MB I2C EEPROM



1 Evaluation Module Overview

Preface: Read This First

1.1.1 Sitara™ MCU+ Academy

Texas Instruments™ offers the [MCU+ Academy](#) as a resource for designing with the MCU+ software and tools on supported devices. The MCU+ Academy features easy-to-use training modules that range from the basics of getting started to advanced development topics.

1.1.2 If You Need Assistance

If you have any feedback or questions, support for the Sitara™ MCUs and the AM263x Control Card development kit is provided by the TI Product Information Center (PIC) and the [TI E2E™ Forum](#). Contact information for the PIC can be found on the [TI website](#). Additional device-specific information can be found in the [Section 6.1](#).

1.1.3 Important Usage Notes

Note

The TMDSCNCD263-PMIC has software examples and drivers in a one-time SDK release. For more information on the installation of the SDK, refer to [Section 3.1](#).

Note

The TMDSCNCD263-PMIC E1 design has various hardware modifications to make sure of proper operation of the EVM. For additional details of all modifications, refer to [Section 5.2](#).

Note

The AM263x Control Card requires a 5 V, 3 A power supply to function. While a USB type-C cable is included, a 5 V, 3 A power supply is not included in the kit and must be ordered separately. For more information, refer to [Section 2.3](#).

Note

TMDSCNCD263-PMIC includes a PMIC and Boost regulator, U30 and U182 which can exceed 55°C case temperature during normal operation. This user guide's statement and the PCB warning sticker from the table below have been added to alert users to these higher temperature components.

	Caution	Caution hot surface. Contact can cause burns. Do not touch!
---	---------	---

Note

External Power Supply or Power Accessory Requirements:

- Nominal output voltage: 5-VDC
 - Max output current: 3000 mA
 - Efficiency Level V
-

Note

TI recommends using an external power supply or accessory which complies with applicable regional safety standards such as (by example) UL, CSA, VDE, CCC, PSE, etc.

1.1 Introduction

The original AM263x Control Card ([TMDSCNCD263](#)) was developed to enable easy and rapid prototyping of the AM263x and all of the peripherals. The changes between the original Control Card and this specific version, [TMDSCNCD263-PMIC](#), is showcased in [Table 1-1](#).

Table 1-1. Control Card Differences

Subsystem	TMDSCNCD263	TMDSCNCD263-PMIC	TMDSCNCD263-PMIC Part Number
Power	Discrete power	Power Management Integrated Chip (PMIC)	O3850QDCARQ1
Voltage Supervisor	N/A	1x Automotive, multichannel window supervisor with very-high accuracy for 1.2 V and 3.3 V supply rails	TPS37042A3OFDDFRQ1
Ethernet	3x Industrial Ethernet PHYs with RJ45 connectors	1x Industrial Ethernet PHY with RJ45 Connector	DP83826ERHBT
		2x Automotive Ethernet PHY with MATEnet connectors	DP83TG720SWRHARQ1

This EVM supports integrated power and safety monitoring that is consistent with ISO26262 ASIL-D by using a PMIC designed for safety-relevant applications as well as an independent, automotive-grade voltage supervisor.

The Control Card described in this user guide has an E1 and E2 revision. The E1 revision of the Control Card requires Hardware modifications for proper use. The E1 design Hardware Modifications are described in [Section 5.2](#). The E2 Design files serve as a reference for the proper implementation of the PMIC with the AM263x. Design files for both E1 and E2 versions of the TMDSCNCD263-PMIC can be found in [Section 4](#).

1.2 Kit Contents

The Sitara AM263x Control Card development kit contains the following items:

- AM263x Sitara series control card development board
- Type-A to Micro-B USB cable (1 meter length)
- USB Type-C Cable (1 meter length)

Note

The maximum length of the IO cables shall not exceed 3 meters.

Not included:

- HSEC 180-pin Baseboard Docking Station
- Standoffs
- USB Type-C 5-V/3-A AC/DC supply and cable

1.3 Specification

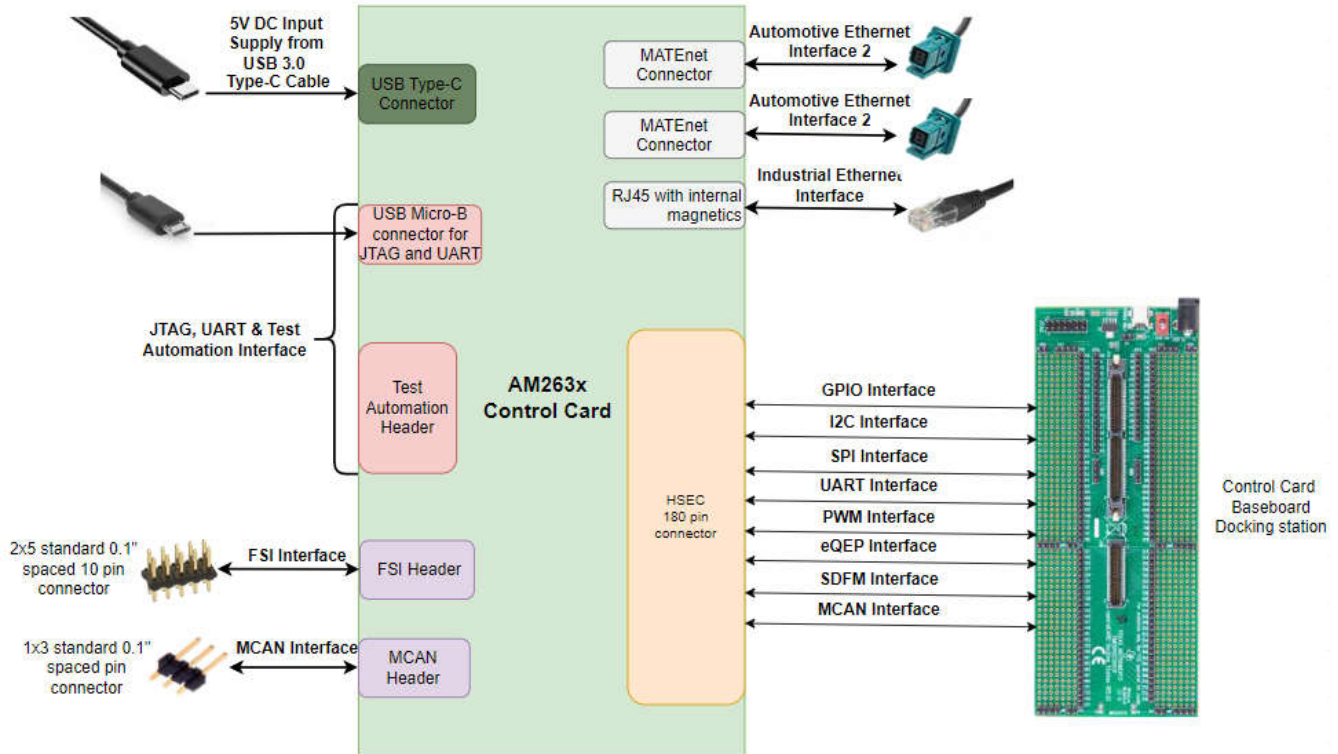

Figure 1-1. System Architecture

1.4 Device Information

The AM263x Sitara™ Arm® Microcontrollers are built to meet the complex real-time processing needs of next generation industrial and automotive embedded products. The AM263x MCU family consists of multiple pin-to-pin compatible devices with up to four 400 MHz Arm® Cortex®-R5F cores. As an option, the Arm® R5F subsystem can be programmed to run in lockstep or dual-core mode for multiple functional safety configurations. The industrial communications subsystem (PRU-ICSS) enables integrated industrial Ethernet communication protocols such as PROFINET®, TSN, Ethernet/IP®, EtherCAT® (among many others), standard Ethernet connectivity, and even custom I/O interfaces. The family is designed for the future of motor control and digital power applications with advanced analog sensing and digital actuation modules.

The multiple R5F cores are arranged in cluster subsystems with 256KB of shared tightly coupled memory (TCM) along with 2MB of shared SRAM, greatly reducing the need for external memory. Extensive ECC is included for on-chip memories, peripherals, and interconnects for enhanced reliability. Granular firewalls managed by the Hardware Security Manager (HSM) enable developers to implement stringent security-minded system design requirements. Cryptographic acceleration and secure boot are also available on AM263x devices.

For additional information about the AM263x, refer to either the data sheet: [AM263x Sitara™ Microcontrollers Data Sheet](#) or the Technical Reference Manual: [AM263x Sitara™ Microcontrollers Technical Reference Manual](#).

1.5 HSEC 180-pin Control Card Docking Station

The [TMDSHSECDOCK 180-pin docking station](#) is available for purchase through Texas Instruments. The docking station is a baseboard that enables rapid prototyping. There is a power switch on the docking station that determines whether power to the Control Card is supplied by the 5 V connector or the USB connector.

Note

The docking station power switch must be toggled to the EXT-ON side to meet the power requirements of the AM263x Control Card. EXT-ON indicates that the power is being sourced from the Barrell connector of the Control Card Dock. The mini-USB (USB-ON) connector does not meet the power requirements of the AM263x Control Card.

The AM263x Control Card has a power mux (TPS2121RUXT) that supplies power from the type-C connection, as long as the voltage supplied by the type-C connection is equal to or greater than the voltage supplied by the HSEC docking station. Therefore, if both a type-C connection is present and the Control Card is connected to a powered HSEC docking station, then the power mux routes the type-C supplied voltage to VMAIN of the Control Card. If there is no type-C connection and voltage is being supplied through the HSEC docking station, then the power mux routes that voltage to VMAIN of the Control Card.

For more information on the docking station, refer to the [180-Pin Docking Station Informational Guide](#).

1.6 Security

The AM263x Control Card features a High Security, Field Securable (HS-FS) device. An HS-FS device has the ability to use a one time programming to convert the device from HS-FS to High Security, Security Enforced (HS-SE).

The AM263x device leaves the TI factory in an HS-FS state where customer keys are not programmed and has the following attributes:

- Does not enforce the secure boot process
- M4 JTAG port is closed
- R5 JTAG port is open
- Security Subsystem firewalls are closed
- SoC Firewalls are open
- ROM Boot expects a TI signed binary (encryption is optional)
- TIFS-MCU binary is signed by the TI private key

The One Time Programmable (OTP) keywriter converts the secure device from HS-FS to HS-SE. The OTP keywriter programs customer keys into the device eFustes to enforce secure boot and establish a root of trust. The secure boot requires an image to be encrypted (optional) and signed using customer keys, which is verified by the SoC. A secure device in the HS-SE state has the following attributes:

- M4, R5 JTAG ports are both closed
- Security Subsystems and SoC Firewalls are both closed
- TIFS-MCU and SBL need to be signed with active customer key

2 Hardware

2.1 Functional Block Diagram

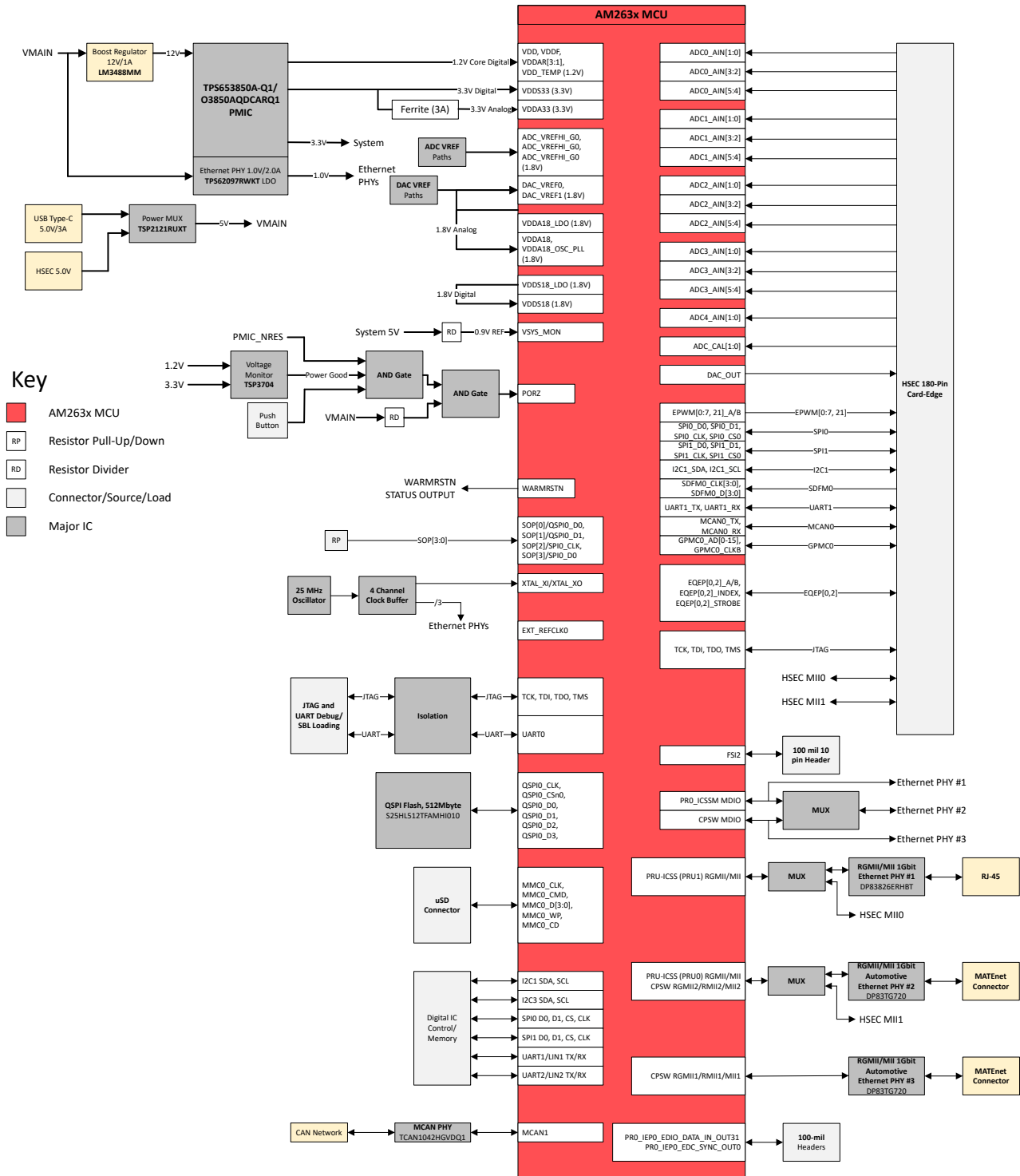

Figure 2-1. AM263x Control Card Block Diagram

2.2 Component Identification

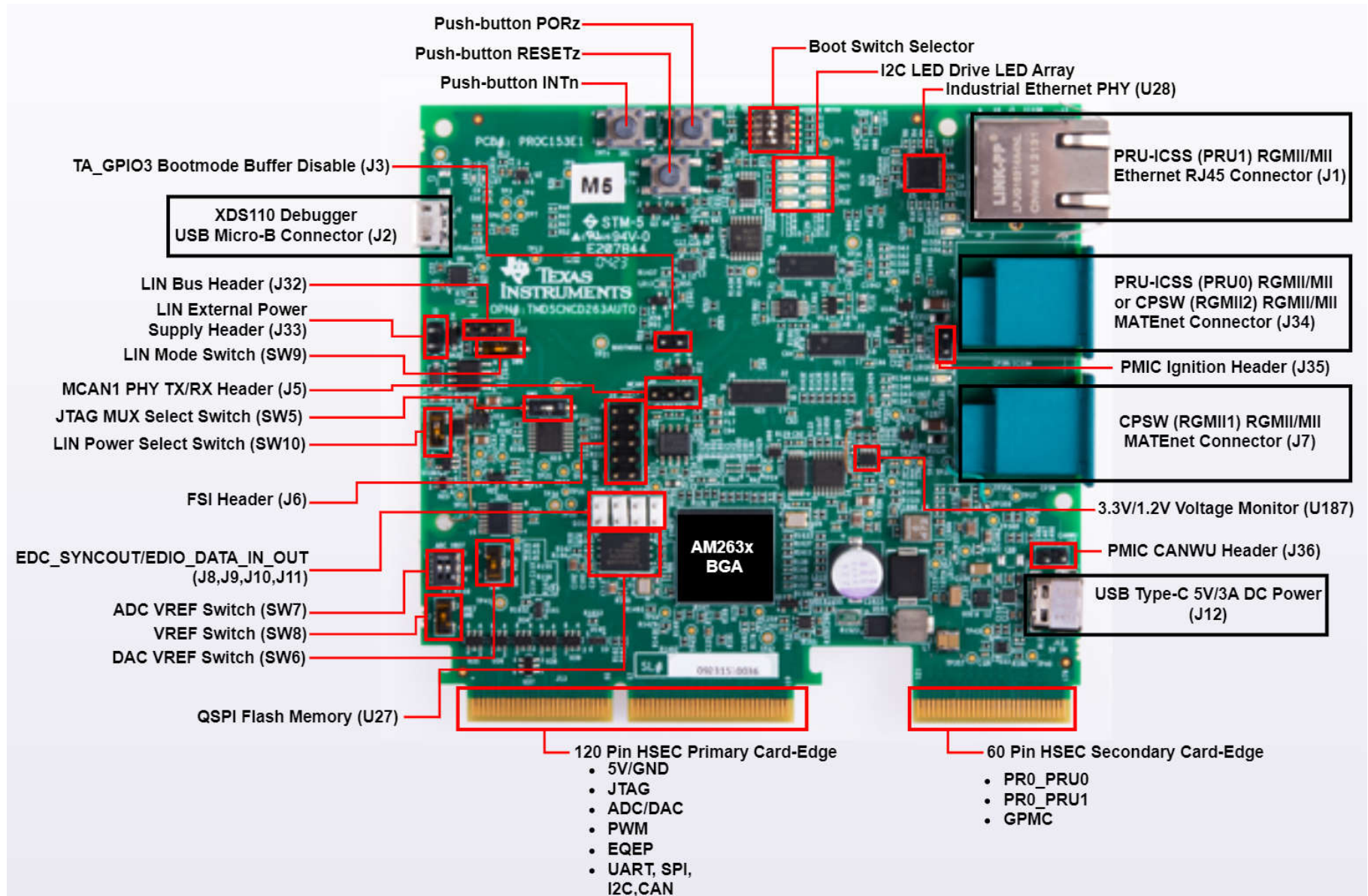

Figure 2-2. Component Identification Front

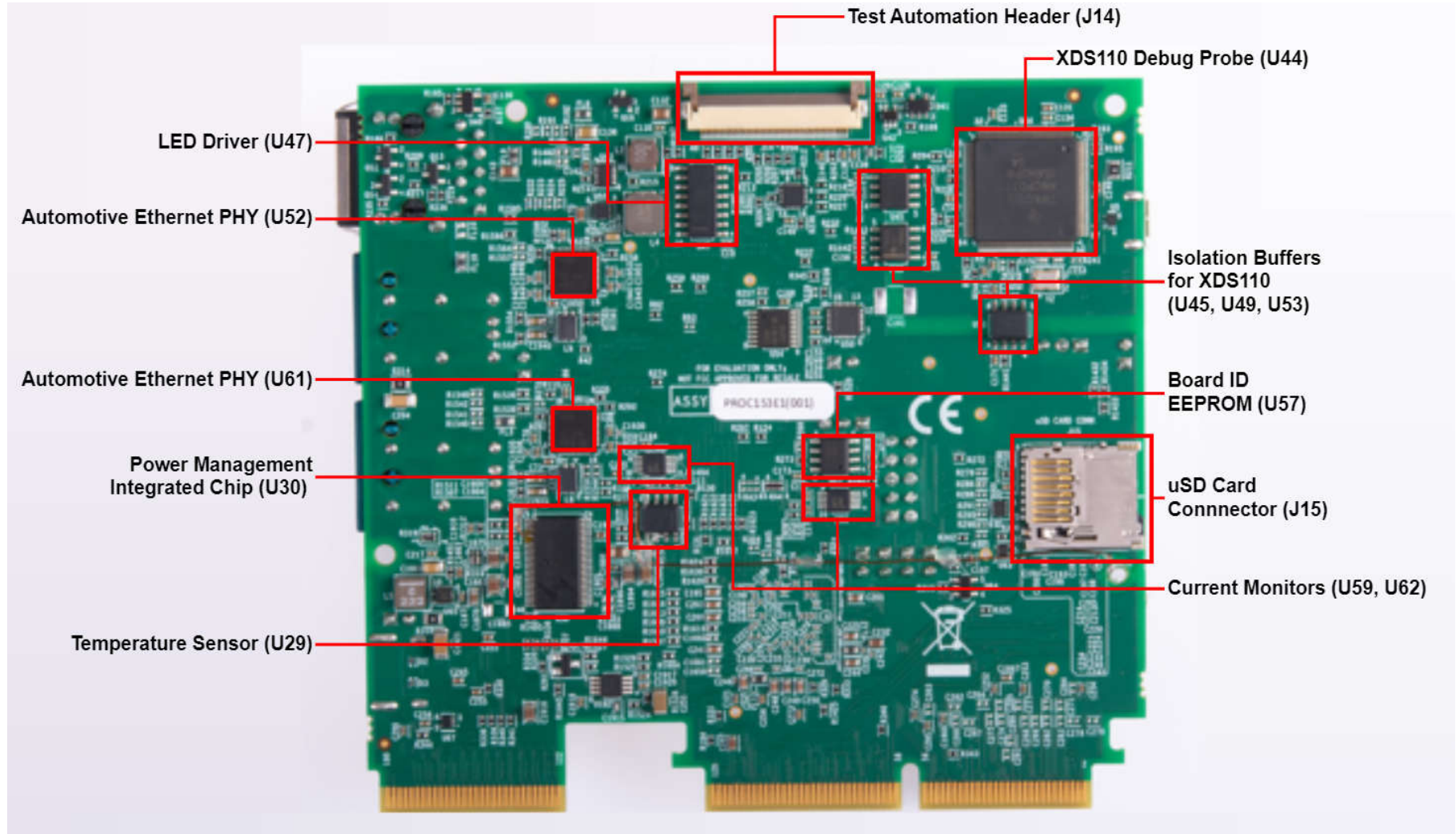

Figure 2-3. Component Identification Back

2.3 Power Requirements

The AM263x Control Card is powered from a 5 V, 3 A USB type-C input or from a 5 V, 3 A HSEC connection supplied by the docking station. The following sections describe the power distribution network topology that supplies the AM263x Control Card, supporting components, and the reference voltages.

Power supply solutions that are compatible with the AM263x Control Card:

- When using the USB type-C input:
 - 5 V, 3 A power adapter with USB-C receptacle
 - 5 V, 3 A power adapter with captive USB-C cable
 - PC USB type-C port that has Power Delivery classification
 - Thunderbolt
 - Battery behind USB logo

	USB 2.0 High Speeds 480 MBit/s	USB 3.0 (USB 3.1 Gen 1) Super Speed 5 GBit/s	USB 3.1 Gen 2 Super Speed Plus 10 GBit/s
Does NOT support Power Delivery			
Does support Power Delivery			
Thunderbolt			
Does support Power Delivery			

Figure 2-4. USB Type-C Power Delivery Classification

- When using the HSEC DC barrel jack power input:
 - A power adapter that is at least 15 W

Power supply solutions that are **NOT** compatible with the AM263x Control Card:

- When using USB type-C input:
 - Any USB adapter cables such as:
 - Type-A to type-C
 - micro-B to type-C
 - DC barrel jack to type-C
 - 5 V, 1.5 A power adapter with USB-C captive cable or receptacle
 - PC USB type-C port not capable of 3 A

2.3.1 Power Input Using USB Type-C Connector

The AM263x Control Card can be powered through a USB type-C connection. The USB Type-C source is capable of providing 3 A at 5 V and advertises the current sourcing capability through the CC1 and CC2 signals. On this EVM, the CC1 and CC2 from the USB type-C connector are interfaced to the port controller IC (TUSB320LAIRWBR). This device uses the CC pins to determine port attach/detach, cable orientation, role

detection, and port control for Type-C current mode. The CC logic detects the Type-C current mode as default, medium, or high depending on the role detected.

The Port pin is pulled down to ground with a resistor to configure the IC in upward facing port (UFP) mode. VBUS detection is implemented to determine a successful attach in upward facing port (UFP) mode. The OUT1 and OUT2 pins are connected to a NOR gate. Active low on both the OUT1 and OUT2 pins advertises high current (3A) in the attached state which enables the load switch (TPS22965DSGT) to provide the VBUS_MAIN supply which powers other regulators that create the power rails for the device.

In UFP mode, the port controller IC constantly presents pull-down resistors on both CC pins. The port controller IC also monitors the CC pins for the voltage level corresponding to the Type-C mode current advertisement by the connected downward facing port (DFP). The port controller IC de-bounces the CC pins and waits for VBUS detection before successfully attaching. As a UFP, the port controller device detects and communicates the advertised current level of the DFP to the system through the OUT1 and OUT2 GPIOs.

The power requirement for AM263x Control Card is 5 V at 3 A. If the source is not capable of providing the required power, then the output at the NOR gate becomes low, disabling the VBUS_MAIN power switch. Therefore, if the power requirement is not met, then all power supplies except VSYS_TA_3V3 remain in an off state. The board gets powered on completely only when the source can provide 5 V at 3 A.

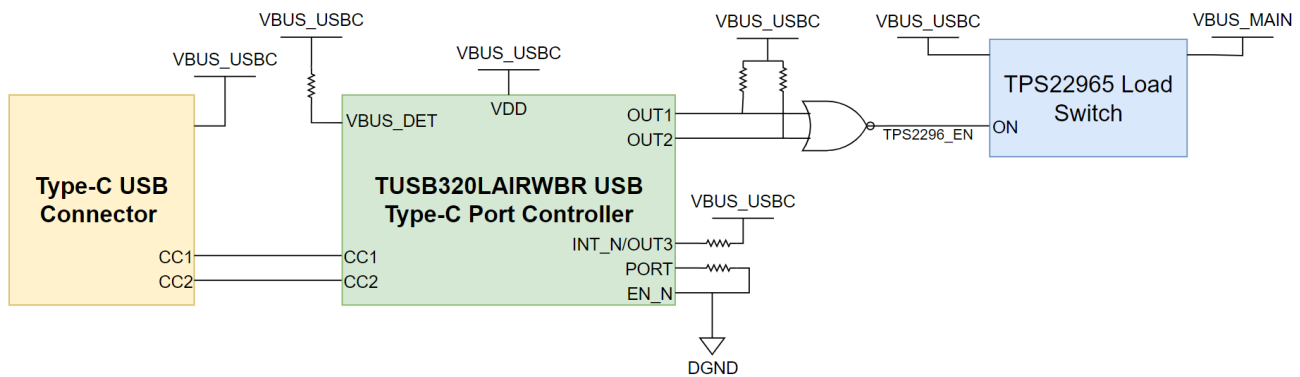

Figure 2-5. Type-C CC Configuration

Table 2-1. Current Sourcing Capability and State of USB Type-C Cable

OUT1	OUT2	Advertisement
H	H	Default current in unattached state
H	L	Default current in attached state
L	H	Medium current (1.5A) in attached state
L	L	High current (3.0A) in attached state

The AM263x Control Card includes a power source based on a Power Management Integrated Chip (PMIC) for each of the power rails. During the initial stage of the power supply, 5 V supplied by the type-C USB connector is used to generate all of the necessary voltages required by the PMIC and subsequently the rest of the board via the PMIC LDO outputs. For more information about the PMIC, refer to [Section 2.3.5](#).

2.3.2 Power Status LEDs

Multiple power-indication LEDs are provided on-board to indicate to users the output status of major supplies. The LEDs indicate power across various domains as shown in the table below.

Table 2-2. Power Status LEDs

Name	Default Status	Operation	Function
LD16	OFF	SAFETY_ERROR	Power error indication for voltage - VUSB_5V0
LD17	ON	VMAIN_12V0	Power indicator for voltage - VMAIN_12V0
LD15	ON	VSYS_3V3A	Power indicator for voltage - VSYS_3V3A
LD14	ON	VSYS_1V2_PG	Power indicator for voltage -VSYS_1V2_PG
LD1	ON	VSYS_TA_3V3	Power indicator for voltage -VSYS_TA_3V3
LD6	OFF	XDS110_PROG_STAZ2	LED glows after XDS configuration
LD7	OFF	XDS110_PROG_STAZ1	

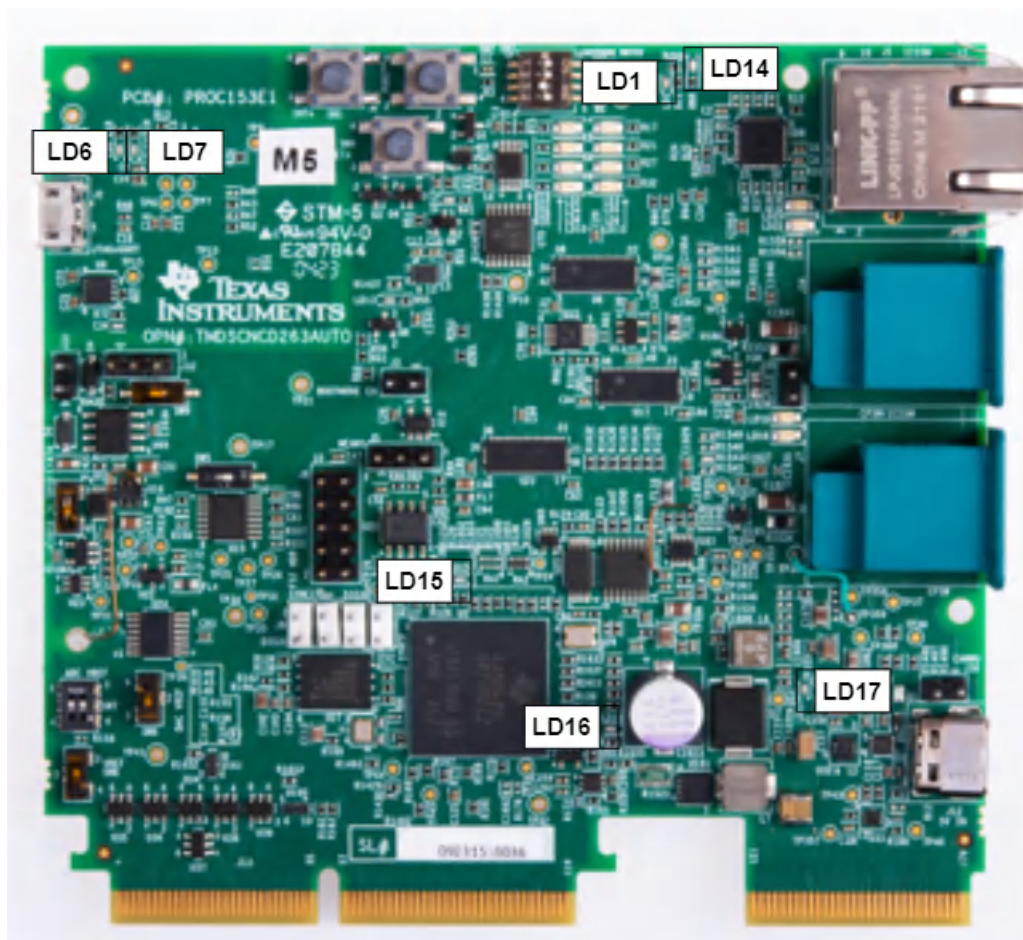
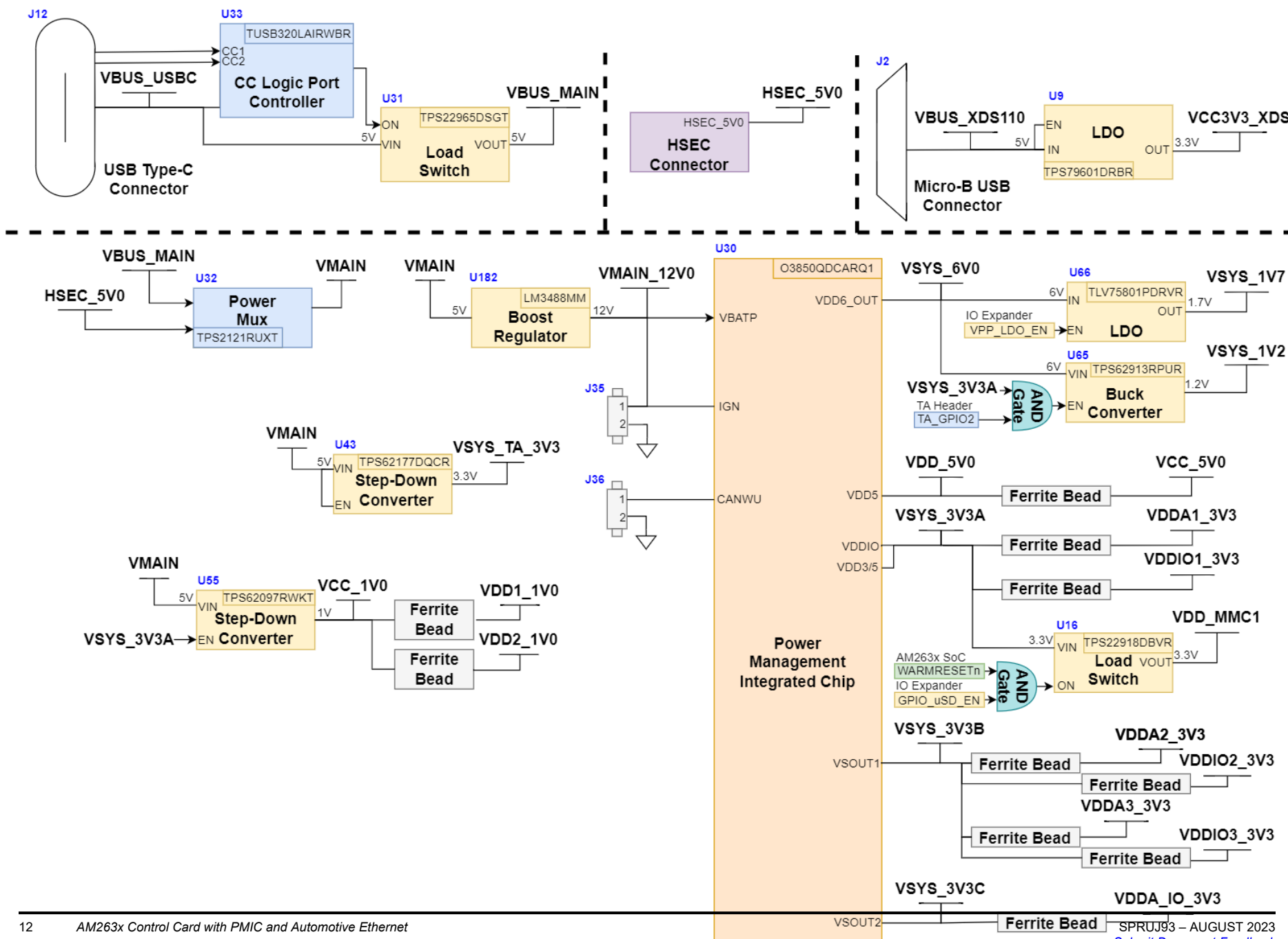

Figure 2-6. Power Status LEDs

2.3.3 Power Tree



2.3.4 Power Sequence

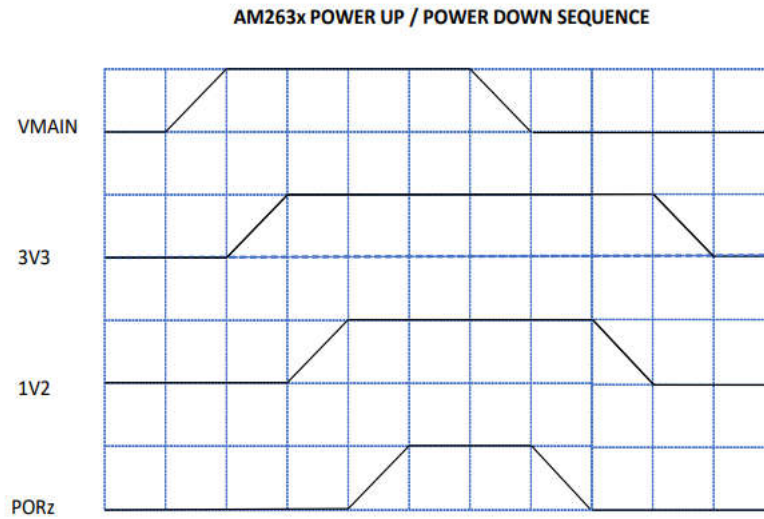

Figure 2-8. Power Sequence Diagram

2.3.5 PMIC

The TMDSCNCD263-PMIC makes use of a Multirail Power Supply for Microcontrollers in Safety-Relevant Applications (**TPS3850QDCARQ1**). The PMIC integrates multiple supply rails to power the MCU, CAN, and other on-board peripherals.

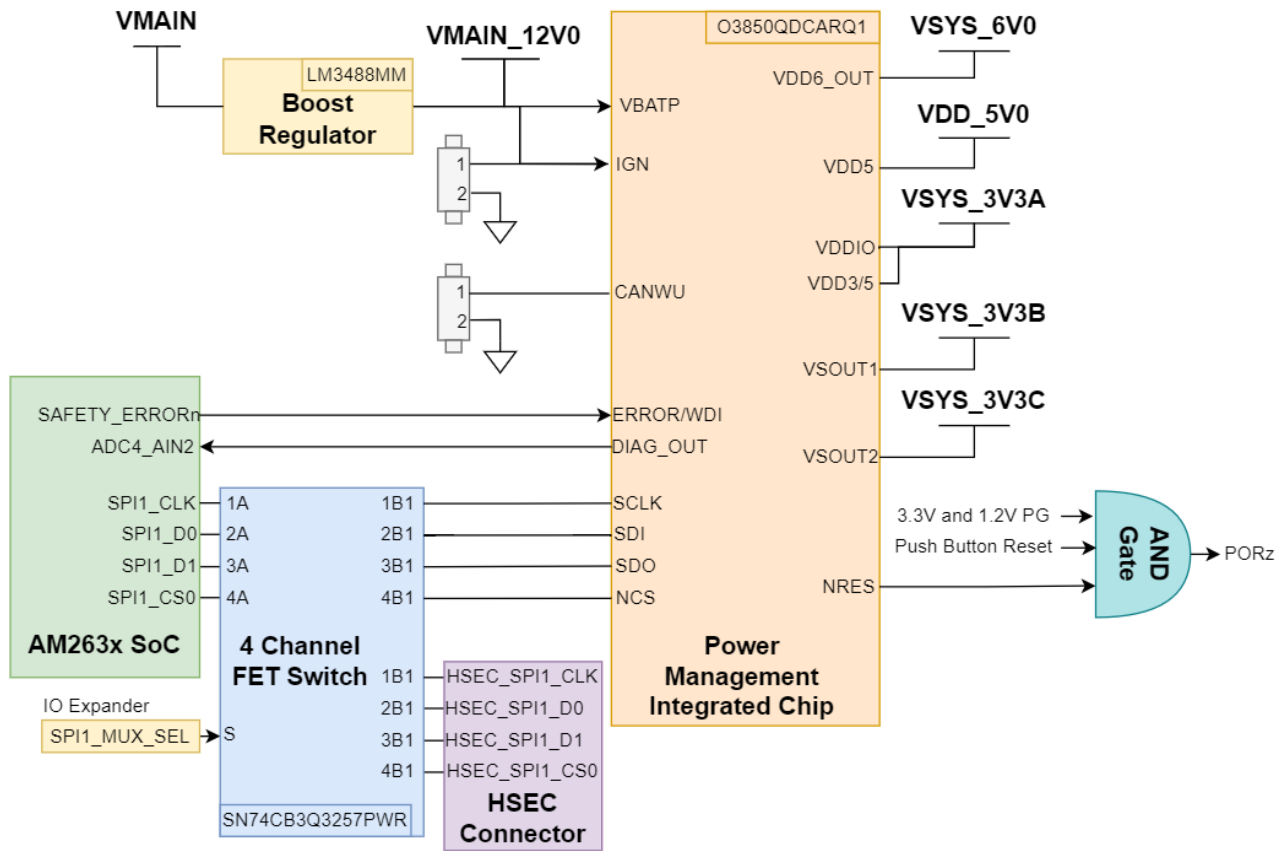

Figure 2-9. PMIC

Note

VSOUT1 and VSOUT2 are not powered on by default and requires a SPI write to enable the relevant supply rails.

The PMIC supports wake-up from an ignition signal (IGN) or wake-up from a CAN transceiver (CAN_WU).

An independent voltage monitoring unit inside the PMIC monitors undervoltage and overvoltage on all internal supply rails and regulator outputs of the battery supply. All supplies are protected with current limiting and overtemperature pre-warning and shutdown.

For more information about the PMIC and features, refer to the [PMIC Data Sheet](#).

2.4 Reset

Figure 2-10 shows the reset architecture of the AM263x Control Card.

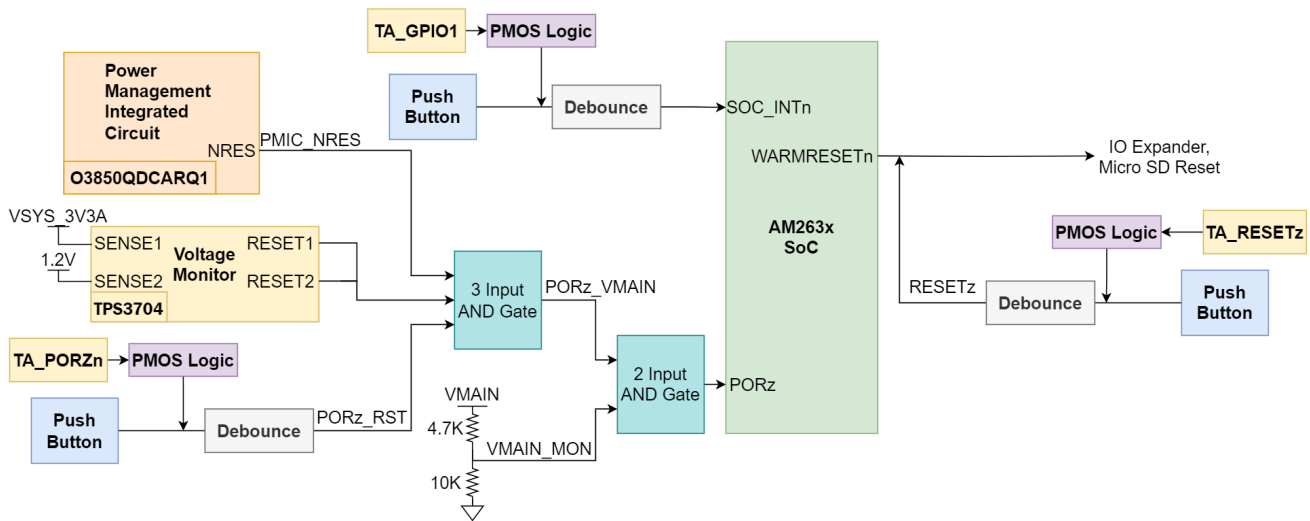

Figure 2-10. Reset Architecture

The AM263x SoC has the following resets:

- PORz is the Power-On-Reset for the MAIN Domain.
- WARMRESETn is the Warm Reset to MAIN Domain.

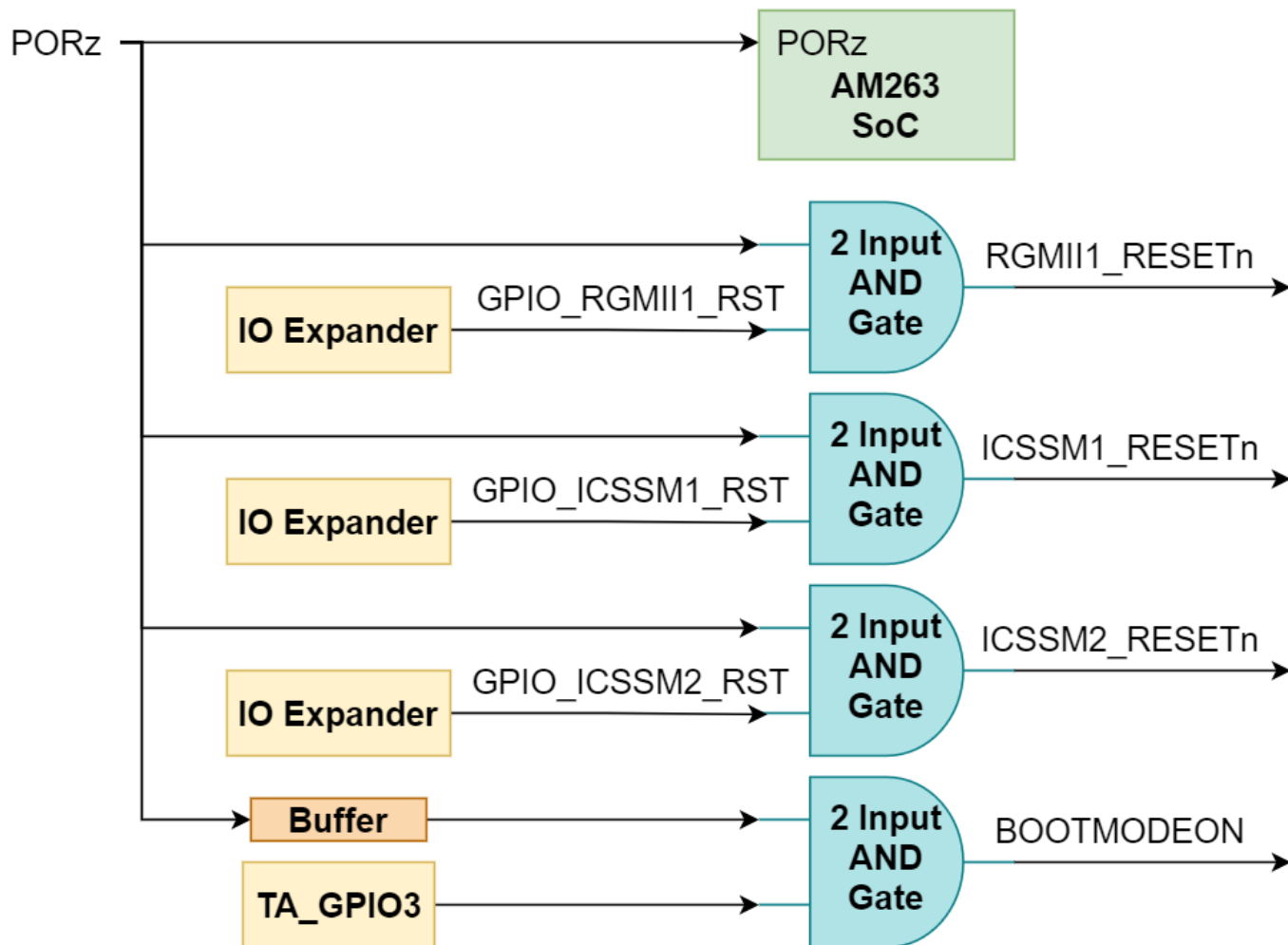

Figure 2-11. PORz Reset Signal Tree

The PORz signal is driven by a 3-input AND gate that generates a power on reset for the MAIN domain when:

- The PMIC drives the NRES, MCU Reset output signal low.
- The Voltage Monitor (TPS37042A3OFDDFRQ1) drives either RESET1 or RESET2 when VSYS_3V3A or VSYS_1V2 respectively are outside of the defined boundaries. For VSYS_3V3A, RESET1 is asserted when SENSE1 is either 8% above or below 3.3 V (including device accuracy). For VSYS_1V2, RESET2 is asserted when SENSE2 is either 5% above or below 1.2 V (including device accuracy).
- The user push button (SW2) is pressed.
- The Test Automation Header outputs a logic LOW signal (TA_PORZn) to a P-Channel MOSFET gate which causes V_{GS} of the PMOS to be less than zero and so the PORz signal connects to the PMOS drain which is tied directly to ground.

The PORz signal is tied to:

- AM263x SoC PORz input
- RGMII1 Ethernet PHY reset
- ICSSM1 Gigabit Ethernet PHY reset
- ICSSM2 Industrial Ethernet PHY reset
- BOOTMODE buffer output enable

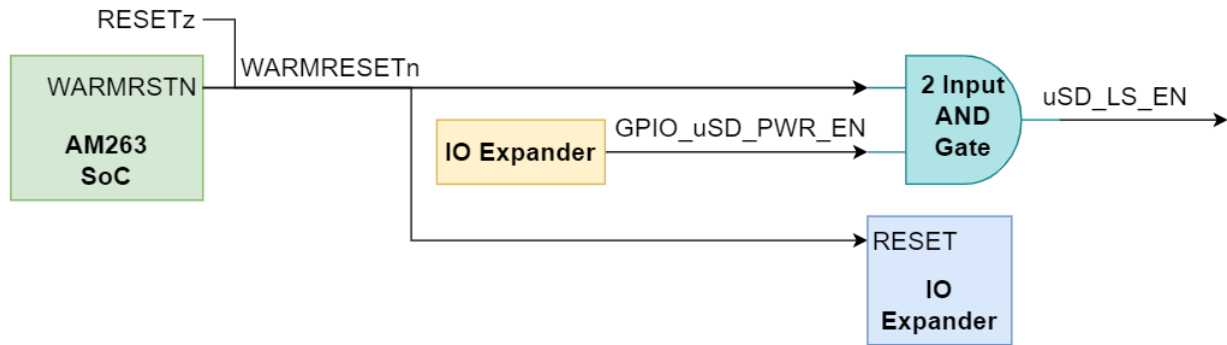

Figure 2-12. WARMRESETn Reset Signal Tree

The WARMRESETn signal creates a warm reset to the MAIN domain when:

- The user push button (SW4) is pressed.
- The Test Automation Header outputs a logic LOW signal (TA_RESETz) to a P-Channel MOSFET gate which causes V_{GS} of the PMOS to be less than zero and so the RESETz signal connects to the PMOS drain which is tied directly to ground.

The WARMRESETn signal is tied to:

- AM263x SoC WARMRESETN output
- RESETz signal created from push button + PMOS logic
- IO Expander reset
- Micro SD reset

The AM263x Control Card also has an external interrupt to the SoC, INTn, that occurs when:

- The user push button (SW1) is pressed.
- The Test Automation Header outputs a logic LOW signal (TA_GPIO1) to a P-Channel MOSFET gate which causes V_{GS} of the PMOS to be less than zero, connecting the INTn signal to the PMOS drain tied directly to ground.

2.5 Clock

The AM263x SoC requires a 25-MHz clock input for XTAL_XI. All reference clocks required for the SoC and the three Ethernet PHYs are generated from a single four output clock buffer (LMK1C1104PWR), which is sourced from a single 25-MHz LVCMOS Oscillator by default. A clock buffer is used for level translation from 3.3 V to 1.8 V.

The Control Card also requires a 16-MHz clock source for the TM4C129 microcontroller for UART-USB JTAG support.

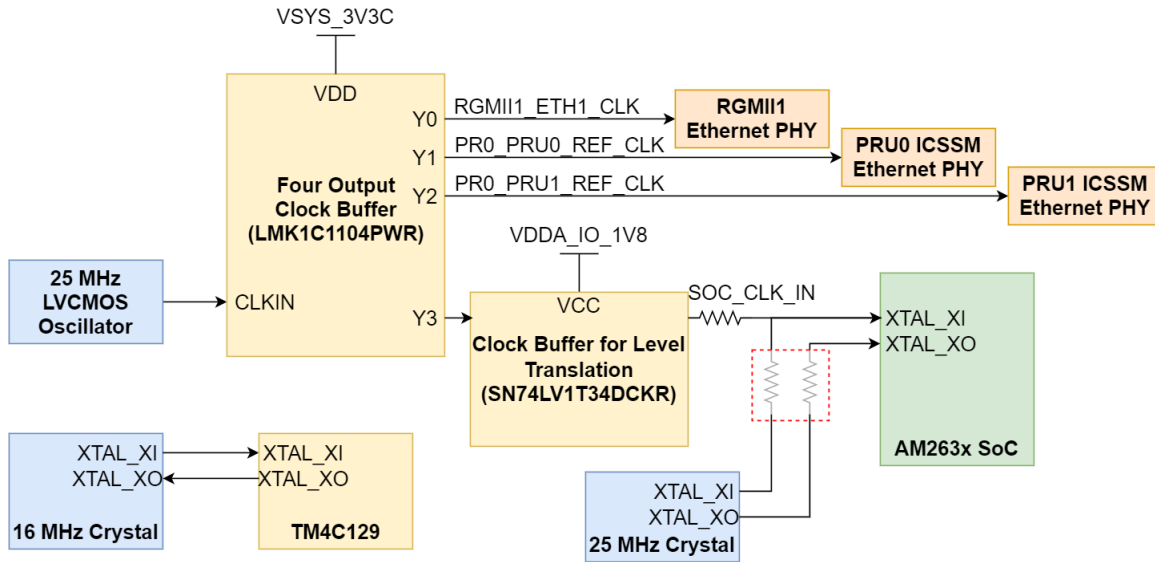

Alternatively, the SoC clock input can be sourced from a single 25-MHz crystal. To use the crystal there must be resistors mounted and unmounted as shown in Table 2-3. When the using a crystal as the SoC clock source, then the AM263x CLKOUT0 signal is used to source the four output clock buffer for the Ethernet PHY reference clock signals.

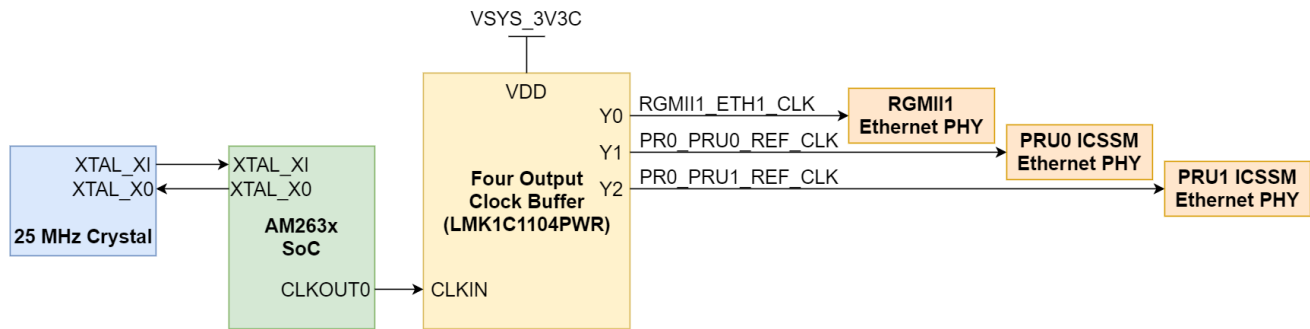

Figure 2-13. Crystal Clock Tree

The following table describes the proper resistors to be mounted and DNI'd for each clock source configuration.

Table 2-3. Clock Source

Clock Source	Mounted	DNI
25-MHz LVCMOS Oscillator (default)	R161, R135	R158, R155, R134
25-MHz Crystal	R158, R155, R134	R161, R135

2.6 Boot Mode Selection

The bootmode for the AM263x is selected by either the DIP switch (SW3) or the test automation header. The test automation header uses an I2C IO expansion buffer to drive the bootmode when PORz is toggled. The supported boot modes are as shown in [Supported Boot Modes](#).

Table 2-4. Supported Boot Modes

Boot Mode/Peripheral	Boot Media/Host	Notes
QSPI (4S) - Quad Read Mode	QSPI Flash	Download and boot SBL from QSPI flash in quad read mode. Attempt Primary SBL, followed by Secondary SBL if primary loading fails.
UART	External Host	Download and boot SBL from UART. Device is expected to get SBL from UART. Device supports the XMODEM protocol for download over UART.
QSPI (1S) - Single Read Mode	QSPI Flash	Download and boot SBL from QSPI flash in single read mode. Attempt Primary SBL, followed by Secondary SBL if primary loading fails.
QSPI (4S) - Quad Read UART Fallback Mode	QSPI Flash / External Host	Download and boot SBL from QSPI flash in quad read mode. Attempt Primary SBL, followed by Secondary SBL if primary loading fails. If Secondary SBL also fails then boot from external host via UART interface.
QSPI (1S) - Single Read UART Fallback Mode	QSPI Flash / External Host	Download and boot SBL from QSPI flash in single read mode. Attempt Primary SBL, followed by Secondary SBL if primary loading fails. If Secondary SBL also fails then boot from external host via UART interface.
DevBoot	N/A	No SBL. Used for development purposes only.

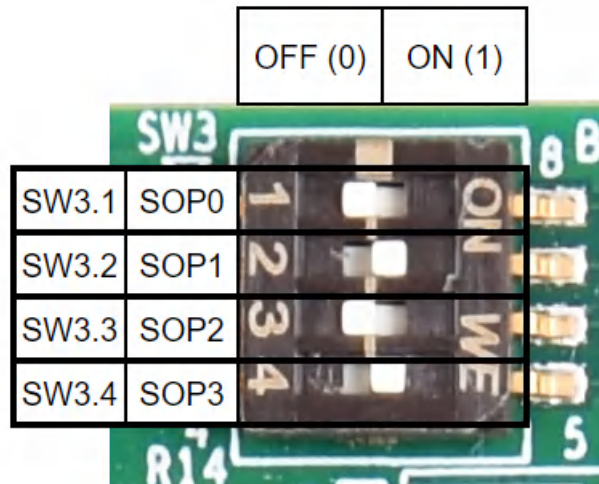

Figure 2-14. SW3 Switch Positions

Table 2-5. Boot-Mode Selection Table

Boot Mode	SPI0_D0_pad (SOP3)	SPI0_CLK_pad (SOP2)	QSPI_D1 (SOP1)	QSPI_D0 (SOP0)
QSPI (4S) - Quad Read Mode	0	0	0	0
UART	0	0	0	1
QSPI (1S) - Single Read Mode	0	0	1	0
QSPI (4S) - Quad Read UART Fallback Mode	0	1	0	0
QSPI (1S) - Single Read UART Fallback Mode	0	1	0	1
DevBoot	1	0	1	1
Unsupported Boot Mode	All other combinations not defined above			

2.7 JTAG Path Selection

The AM263x Control Card allows for JTAG connections to the SoC through the on-board XDS110 or an external emulator via the HSEC docking station. A switch (SW5) is used to drive the select line of a mux (U19) to determine the JTAG path for the SoC. [Section 2.12.9](#) provides additional detail on JTAG pathing.

2.8 Header Information

This version of the AM263x Control Card has 11 different headers. For the locations of each header, refer to [Section 2.2](#). The signal details for each header pin is detailed below.

- Test Automation Bootmode Control Header
 - For more information about the Test Automation Header, refer to [Section 2.12.10](#)

Table 2-6. Test Automation Header

Designator	Pin 1	Pin 2
J3	TA_GPIO3	DGND

- MCAN Header
 - For more information about the MCAN interface, refer to [Section 2.12.7](#)

Table 2-7. MCAN Header

Designator	Pin 1	Pin 2	Pin 3
J5	MCAN1_CAN_H	DGND	MCAN1_CAN_L

- FSI Header
 - For more information about the FSI Interface, refer to [Section 2.12.8](#)

Table 2-8. FSI Header

Designator	Pin 1	Pin 2	Pin 3	Pin 4	Pin 5	Pin 6	Pin 7	Pin 8	Pin 9	Pin 10
J6	FSIRX2_CLK	FSITX2_CLK	DGND	DGND	FSIRX2_DATA0	FSITX2_DATA0	FSIRX2_DATA1	FSITX2_DATA1	DGND	VSYS_3V3A

- PRU-ICSS IEP Headers
 - For more information about the PRU-ICSS, refer to [Section 2.12.2.2](#)

Table 2-9. PRU-ICSS IEP Headers

Designator	Pin 1	Pin 2
J8	PR0_IEP0_EDIO_DATA_IN_OUT_31	DGND
J9	PR0_IEP0_EDC_SYNC_OUT1	DGND
J10	PR0_IEP0_EDIO_DATA_IN_OUT_30	DGND
J11	PR0_IEP0_EDC_SYNC_OUT0	DGND

- LIN Headers
 - For more information about the LIN interface, refer to [Section 2.12.11](#)

Table 2-10. LIN Headers

Designator	Pin 1	Pin 2	Pin 3
J32	VLIN	LIN	DGND
J33	VBAT_LIN	DGND	N/A

- PMIC Headers
 - For more information about the PMIC, refer to [Section 2.3.5](#)

Table 2-11. PMIC Headers

Designator	Pin 1	Pin 2
J35	IGNITION	DGND
J36	CANWU	DGND

2.9 GPIO Mapping

Table 2-12. GPIO Mapping Table

SI No.	GPIO Description	GPIO	Pin Name	Functionality	Net Name	Active Status
1	Interrupt To SoC	GPIO21	LIN2_RXD	Interrupt	SOC_INTn	LOW
2	Interrupt To DP83826E	GPIO66	EPWM12_A	Interrupt	ICSSM2_PWDN/INTn	LOW
3	Interrupt To DP83TG720_01	GPIO67	EPWM11_B	Interrupt	RGMI11_INT	LOW
4	Interrupt To DP83TG720_02	GPIO68	EPWM12_B	Interrupt	ICSSM1_INT	LOW
5	User Defined LED	GPIO20	LIN2_TXD	GPIO	USER_LED0	PREFERABLE
6	PMIC DIAG OUT TO SoC	GPIO1	QSPI0_CSn1	GPIO	PMIC_DIAG_OUT	LOW
IO Expander 01						
7	Standby input to CAN transceiver		P00	GPIO	MCAN1_STB	High
8	Enable control to clock buffer		P01	Enable	CLK_BUF_EN	High
9	Select line for ICSSM Mux 1		P02	Mux Selection	ICSSM1_MUX_SEL	PREFERABLE
10	Select line for ICSSM Mux 2		P03	Mux Selection	ICSSM2_MUX_SEL	PREFERABLE
11	Reset input to DP83869_01		P04	Reset	GPIO_RGMI11_RST	LOW
12	Reset input to DP83869_02		P05	Reset	GPIO_ICSSM1_RST	LOW
13	Reset input to DP83826E		P06	Reset	GPIO_ICSSM2_RST	LOW
14	Enable control to SD load switch		P07	Load SW Enable	GPIO_uSD_PWR_EN	High
15	User Defined LED		P10	GPIO	USER_LED1	PREFERABLE
16	Select line for I2C0 MUX		P11	Mux Selection	I2C0_MUX_SEL	PREFERABLE
17	Select line for SPI1 MUX		P12	Mux Selection	SPI1_MUX_SEL	PREFERABLE
18	Enable control to 1.7V LDO		P13	LDO Enable	VPP_LDO_EN	PREFERABLE
19	Select line for MDIO/MDC MUX		P14	Mux Selection	MDIO/MDC_MUX_SEL	PREFERABLE
20	Select line for LIN/UART MUX		P15	Mux Selection	LIN_MUX_SEL	PREFERABLE
21	Select line for ADC MUX		P16	Mux Selection	ADC1_MUX_SEL	PREFERABLE
22	Select line for ADC MUX		P17	Mux Selection	ADC2_MUX_SEL	PREFERABLE

2.10 Push Buttons

The control card supports multiple user push buttons that provide reset inputs and user interrupts to the processor.

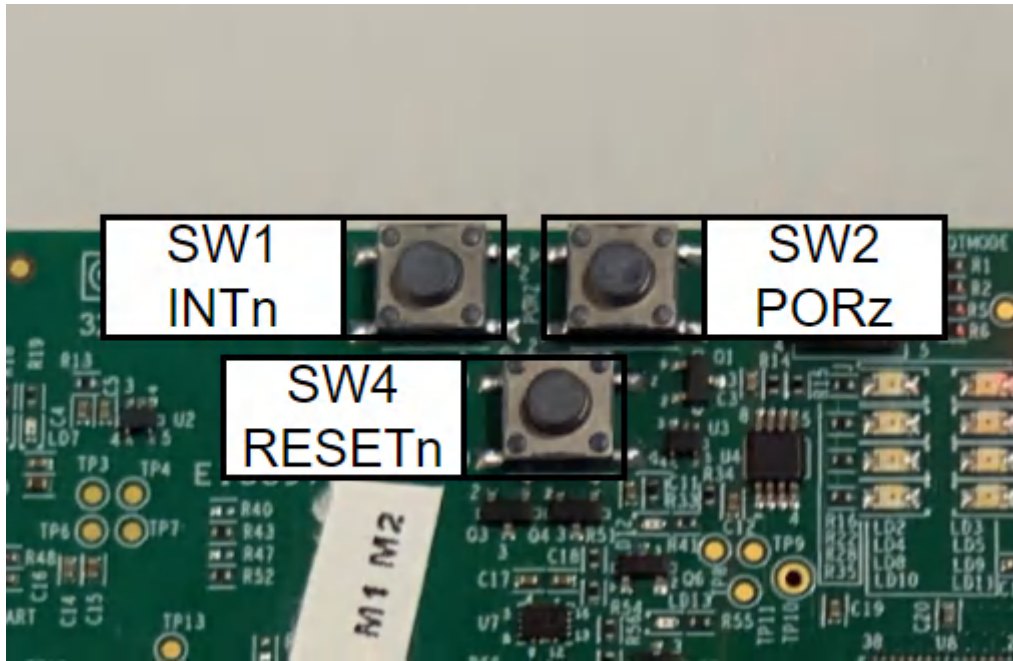

Figure 2-15. Push Buttons

[Control Card Push Buttons](#) lists the push buttons that are placed on the top side of the AM263x Control Card board.

Table 2-13. Control Card Push Buttons

Push Button	Signal	Function
SW1	INTn	User Interrupt signal
SW2	PORz	SoC PORz reset input
SW4	RESETn	SoC warm reset input

2.11 Test Points

The following table describes all test points available on the Control Card.

Table 2-14. Control Card Test Points

Designator	Signal
TP1	VSYS_TA_3V3
TP2	VCC3V3_XDS
TP3	TM4C129_TCK
TP4	TM4C129_TMS
TP6	TM4C129_TDI
TP7	TM4C129_TDO
TP13	TM4C129_RST#
TP14	PRU-ICSS Ethernet PHY CLK_OUT2
TP15	VBUS_XDS110
TP20	RGMII1 Ethernet PHY CLK_OUT1
TP22	VDD_MMC1
TP23	SOC_TDI
TP24	SOC_MMC0_CLK
TP25	SOC_TDO
TP26	SOC_TMS
TP27	SOC_TCK
TP29	WARMRESETn
TP31	MMC0_WP
TP32	PORz
TP33	RSVD
TP35	VDD_IO_3V3
TP36	DGND
TP37	VCC_1V2
TP39	VSYS_1V2
TP40	SAFETY_ERRORn
TP41	DGND
TP42	VSYS_1V7
TP43	TUSB320 ID
TP44	VSYS_MON
TP45	RSVD
TP353	PMIC_NRES
TP354	PMIC_DIAG_OUT
TP355	PMIC_ENDRV
TP356	PMIC_ERROR-WDI
TP357	VBUS_USBC
TP358	VDD_5V0
TP359	VSYS_3V3A
TP360	VSYS_6V0
TP361	VSYS_3V3B
TP362	VSYS_3V3C
TP363	VMAIN_12V0

2.12 Interfaces

2.12.1 Memory Interface

2.12.1.1 QSPI

The AM263x Control Card has a 128 Mbit QSPI memory device (S25FL128SAGNFI000), which is connected to the QSPI0 interface of the AM263x SoC. The QSPI supports single data rates with memory speeds up to 104 MHz. The QSPI flash is powered by the 3.3-V IO supply (VSYS_3V3A).

Note

There is typically a reset pin for flash memory. The reset pin is not present in the WSON package that is used in the Control Card.

The QSPI0_D0/D1 signals are also used for BOOTMODE control logic. There are 10-k Ω resistors used to isolate the BOOTMODE control logic after the value is latched.

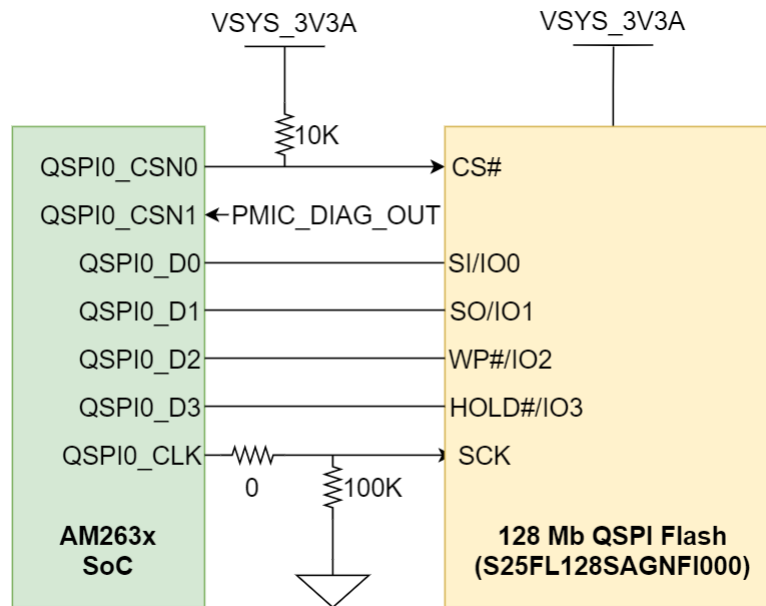

Figure 2-16. QSPI

2.12.1.2 Board ID EEPROM

The AM263x Control Card has a I2C based 1 Mbit EEPROM (CAT23M01WI-GT3) to store board configuration details. The Board ID EEPROM is connected to the I2C0 interface of the AM263x through a 1:2 mux (SN74CB3Q3257PWR). The default I2C address of the EEPROM is set to 0x50 by pulling down the address pins A1 and A2 to ground. The Write Protect pin for the EEPROM is by default pulled down to ground and therefore disabled. There is also the option to enable Write Protect by removing the 10 kΩ pull down resistor (R273) and mounting a pull up resistor (R268) to the 3.3 V IO voltage supply.

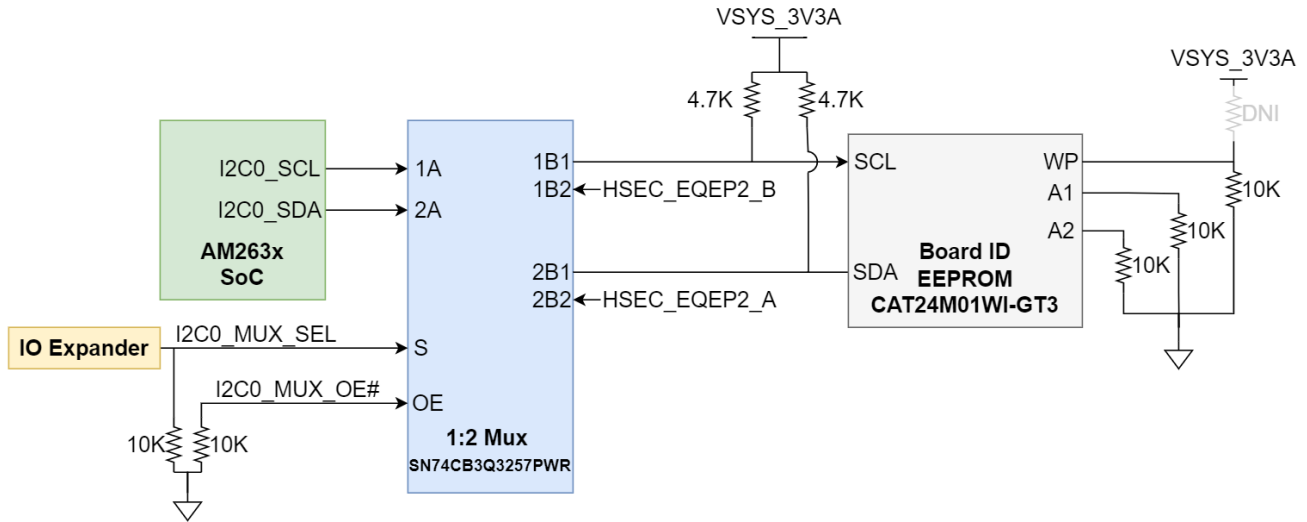

Figure 2-17. Board ID EEPROM

The GPIO Expander is used to control the select signal (I2C0_MUX_SEL) of the 1:2 Mux.

Table 2-15. EEPROM Mux Table

Select	Condition	Mux Function
HIGH	HSEC EQEP Selected	A→B2 port
LOW	I2C0 Selected	A→B1 port

2.12.2 Ethernet Interface

2.12.2.1 RGMII

The AM263x Control Card uses one port of RGMII signals to be connected to a 48-pin Ethernet PHY (DP83TG730SWRHARQ1). The PHY is configured to advertise 1-Gb operation. The Ethernet data signals of the PHY are terminated to a MATEnet Connector. LEDs are used to indicate link status and activity.

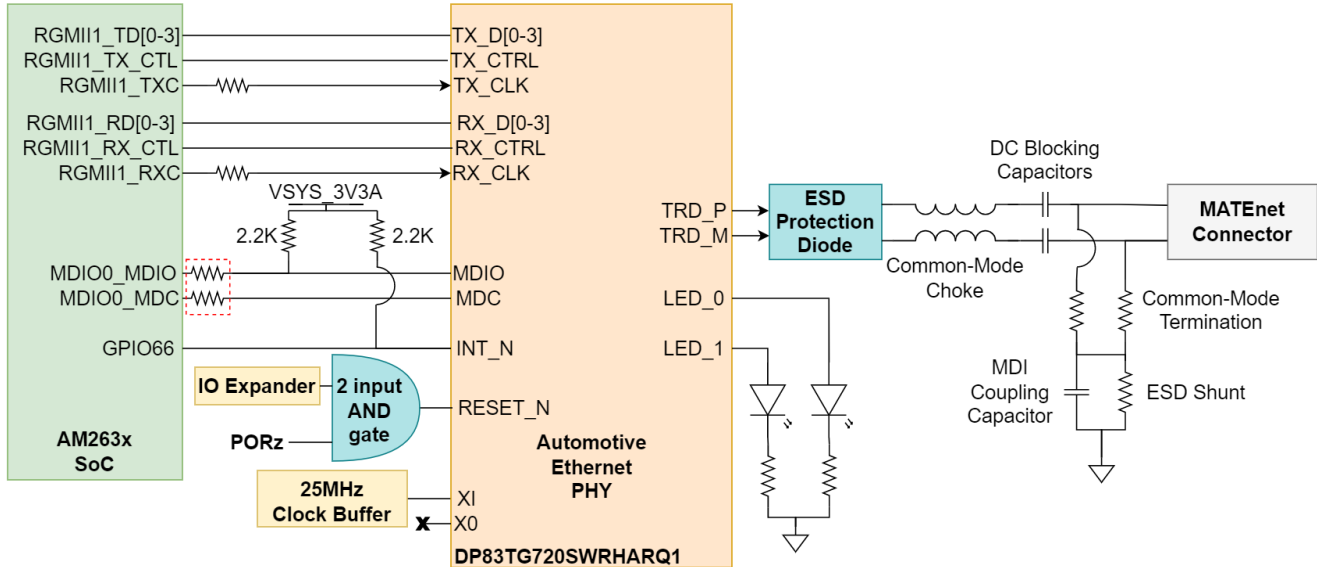

Figure 2-18. RGMII1 Automotive Ethernet PHY

The Ethernet PHY requires three separate power sources. VSYS_3V3A from the PMIC is filtered using two different ferrite beads to supply voltage to VDDIO and VDDA of the Ethernet PHY. There is a dedicated LDO for the 1.0 V supply for the Ethernet PHY.

There are series termination resistors on the transmit and receive clock signals located near the AM263x SoC.

The MDIO and interrupt signals from the SoC to the PHY require 2.2 k Ω pull up resistors to the I/O supply voltage for proper operation. The interrupt signal is driven by a GPIO signal that is mapped from the AM263x SoC.

The reset signal for the Ethernet PHY is driven by a 2-input AND gate. The AND gate's inputs are a GPIO signal that is generated by the IO Expander and PORz.

The Ethernet PHY uses many functional pins as strap option to place the device into specific modes of operation.

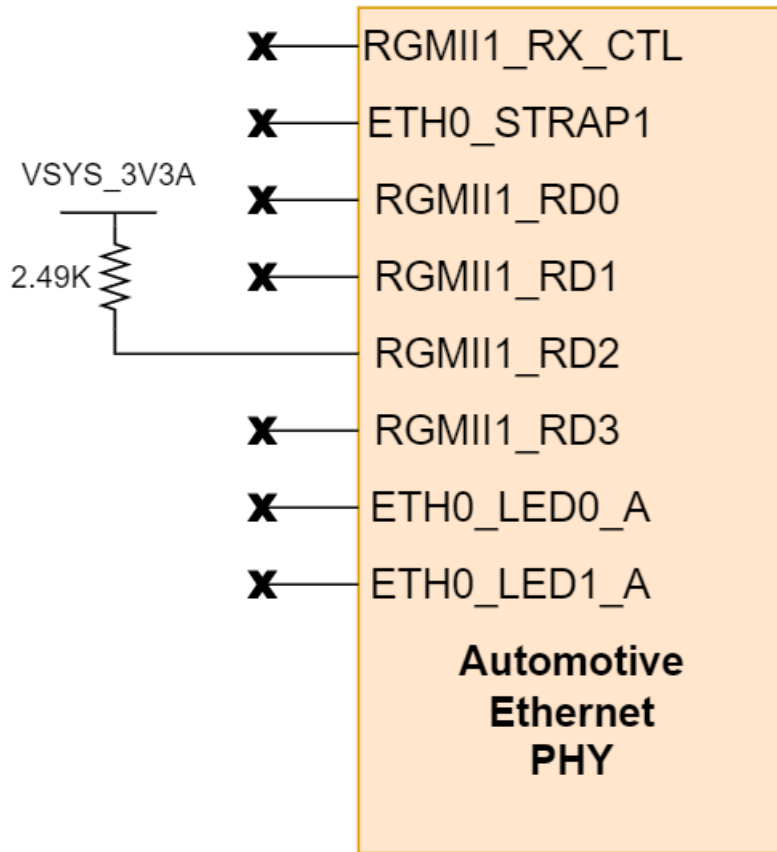

Figure 2-19. RGMII1 Automotive Ethernet PHY Strapping Resistors

Note

Each strapping has an internal pull down resistance.

Table 2-16. RGMII1 Gigabit Ethernet PHY Strapping Resistors

Functional Pin	Default Mode	Mode in CC	Function
RX_D0	0	0	RGMII (Align Mode)
RX_D1	0	0	
RX_D2	0	1	
RX_CTRL	0	0	PHY Address: 0x0000
STRP_1	0	0	
LED_0	0	0	MS: Peripheral
LED_1	0	0	AUTO: Autonomous

2.12.2.2 PRU-ICSS

Note

The PRU internal pinmux mapping provided in the TRM is part of the original hardware definition of the PRU. However, due to the flexibility provided by the IP and associated firmware configurations, this is not a hard requirement. The first PRU implementation for AM65x had the MII TX pins swapped during initial SoC integration and this convention was maintained for subsequent PRU revisions to enable firmware reuse. To make use of the SDK firmware, use the SYSCONFIG generated PRU pin mapping.

The AM263x Control Card makes use of two on-die programmable real-time unit and industrial communication subsystem's (PRU-ICSS) of the AM263x SoC to interface with two Ethernet PHY transceivers. There is a Automotive Ethernet PHY transceiver (DP83TG720SWRHARQ1) connected to PRU0 of the SoC and an Industrial Ethernet PHY transceiver (DP83826ERHBT) connected to PRU1. The Ethernet data signals of the Automotive Ethernet PHY are terminated to a MATEnet Connector while the Industrial Ethernet PHY data signals are terminated to an RJ45 connector. The MATEnet Connector used on the board supports Gigabit Ethernet by the IEEE 802.3 standard 1000BASE-T1. The RJ45 connector used on the board supports 10/100 (DP83826ERHBT) Mbps connectivity with integrated magnetic and LEDs for link and activity indication.

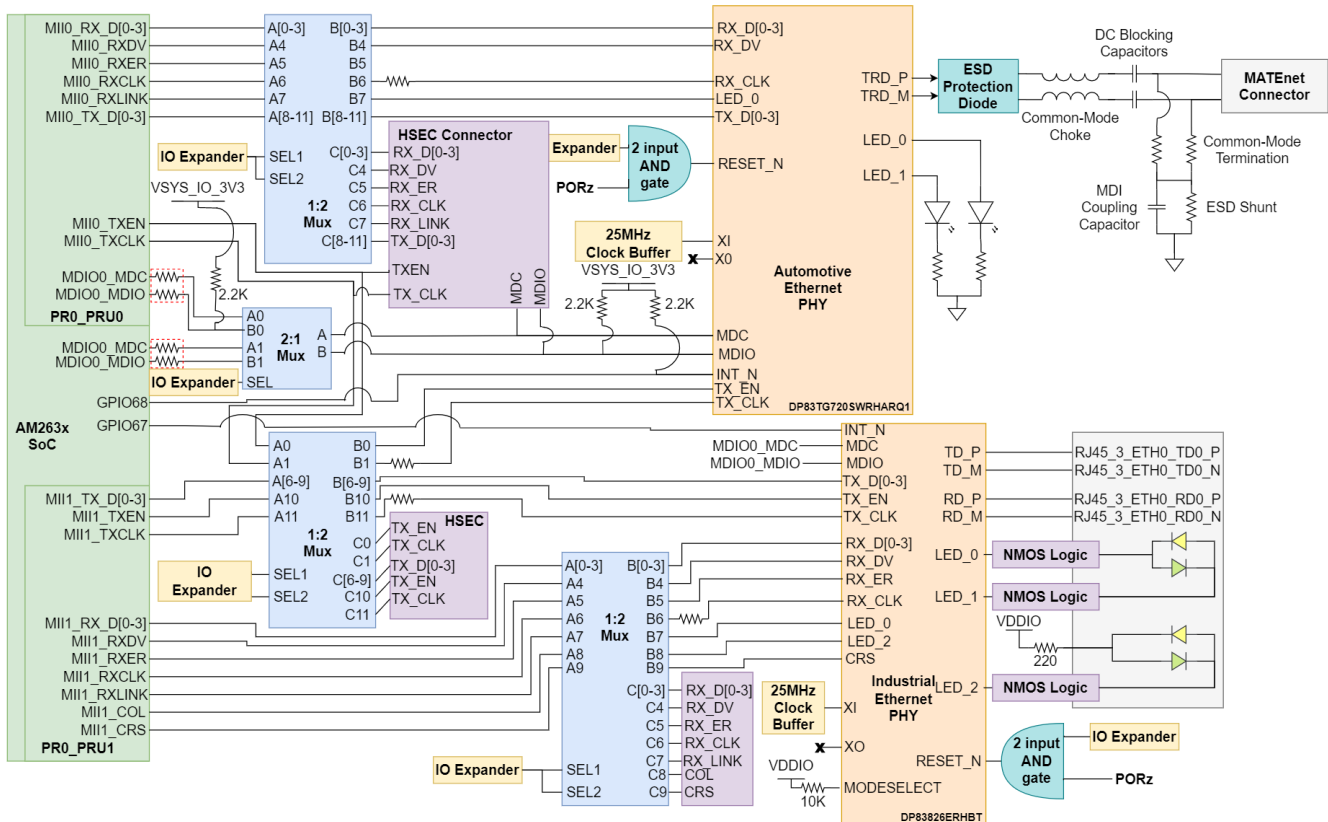

Figure 2-20. PRU-ICSS Overview

For the Automotive Ethernet PHY:

- The Ethernet PHY requires three separate power sources. VSYS_3V3A from the PMIC is filtered using two different ferrite beads to supply voltage to VDDIO and VDDA of the Ethernet PHY. There is a dedicated LDO for the 1.0V supply for the Ethernet PHY.
- The Ethernet PHY uses many functional pins as strap options to place the device into a specific mode of operation. Each functional pin has a default mode that is driven by an internal pull resistor.
- There is a 2:1 mux (TMUX154EDGSR) that controls the mapping of MDIO and MDC signals for the ethernet PHY's.

Table 2-17. Gigabit Ethernet PHY MDIO/MDC MUX

SEL	Condition	Function
HIGH	AM263x SoC MDIO0 MDIO/MDC signals selected	A1/B1→A/B port
LOW	PRU MDIO/MDC signals selected	A0/B0→ A/B port

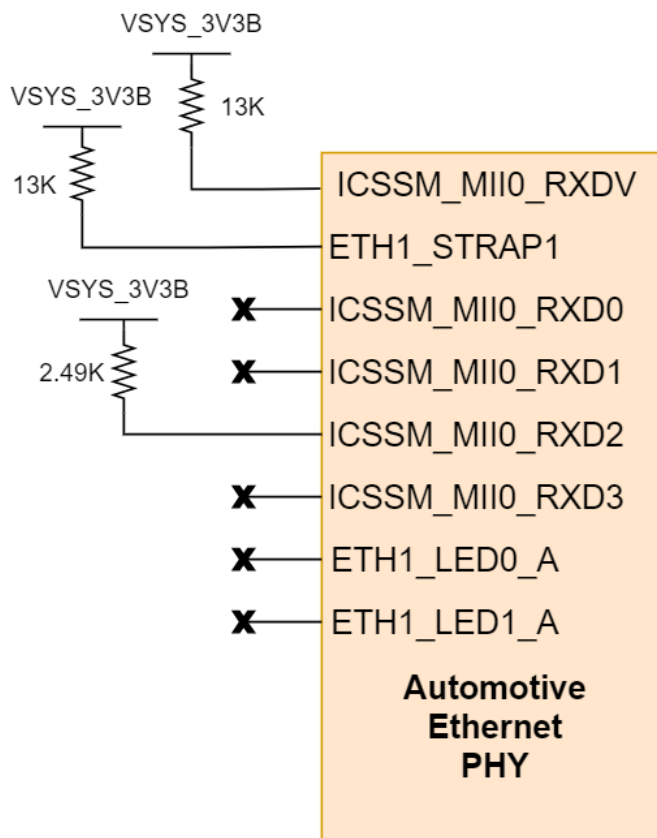

Figure 2-21. PRU0 ICSS Automotive Ethernet PHY Strapping Resistors

Table 2-18. PRU0 ICSS Automotive Ethernet PHY Strapping Resistors

Functional Pin	Default Mode	Mode in CC	Function
RX_D0	0	0	RGMII (Align Mode)
RX_D1	0	0	
RX_D2	0	1	
RX_CTRL	0	1	PHY Address: 0x000C
STRP_1	0	1	
LED_0	0	0	MS: Peripheral
LED_1	0	0	AUTO: Autonomous

For the Industrial Ethernet PHY transceiver:

- The Ethernet PHY requires two separate power sources. VSYS_3V3B from the PMIC is filtered by two separate ferrite beads to be used as the supply for VDDIO and VDDA3V3.
- The Ethernet PHY is set to ENHANCED mode by pulling the MODESELECT pin up to VSYS_3V3B.
 - ENHANCED mode allows the DP83826E to support real-time Ethernet applications in addition to standard Ethernet applications.
- The Ethernet PHY uses many functional pins as strap options to place the device into a specific mode of operation. Each functional pin has a default mode that is driven by an internal pull resistor

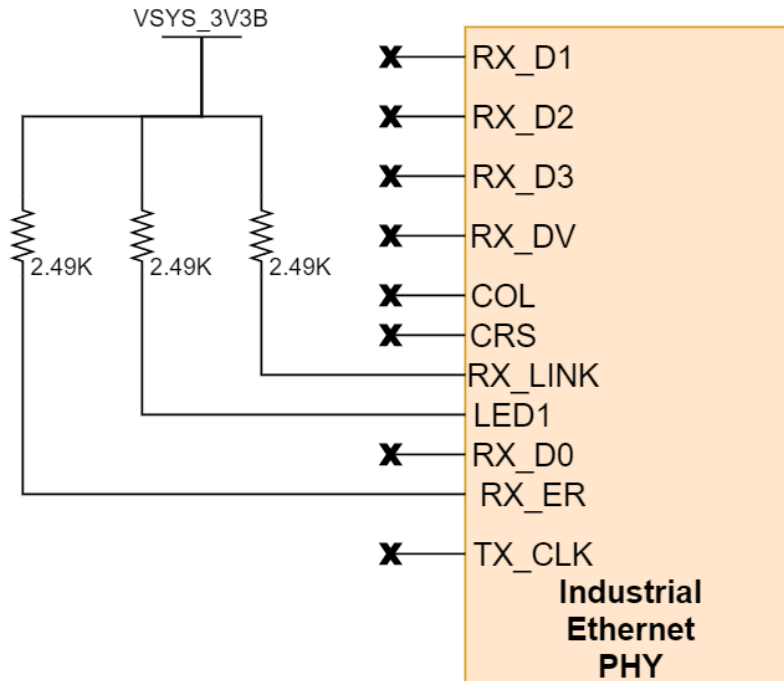

Figure 2-22. PRU1 ICSS Industrial Ethernet PHY Strapping Resistors

Table 2-19. PRU1 ICSS Industrial Ethernet PHY Strapping Resistors

Functional Pin	Default Mode	Mode in CC	Function
RX_D0	1	1	auto-negotiation enable
LED1	1	1	odd nibble detection enable
RX_LINK	0	1	PHY address: 001
CRS	0	0	
COL	0	0	
TX_CLK	0	0	RMII Controller Mode
RX_ER	0	1	LED1 on pin 31
RX_D3	0	0	fast link-drop disable
RX_D2	0	0	MII MAC mode
RX_D1	0	0	Auto MDIX enable
RX_DV	0	0	MDIX (applicable only when auto-MIDX is disabled)

For both Ethernet PHYs:

- There are series termination resistors on the transmit and receive clock signals located near the AM263x SoC.
- The MDIO and Interrupt signals from the SoC to the PHY require 2.2KΩ pull up resistors to the I/O supply voltage for proper operation. The interrupt signal is driven by a GPIO signal that is mapped from the AM263x SoC.
- The reset signal for the Ethernet PHY is driven by a 2-input AND gate. The AND gate's inputs are a GPIO signal that is generated by the IO Expander and PORz.

- A 25 MHz clock is sourced from a four output clock buffer that has a 25 MHz oscillator as an input.
- There are three 1:2 muxes (TS3DDR3812RUAR) that control the mapping of ethernet signals from the SoC to either the Ethernet PHY's or the HSEC connector. The select logic for the three muxes is driven by two GPIO signals that are generated by the IO expander.

Table 2-20. ICSS HSEC MUX

Select Signal	Logic Level	Condition	Function
ICSSM1_MUX_SEL	LOW	PRU0 signals mapped to Ethernet PHY	A[n] → B[n]
	HIGH	PRU0 signals mapped to HSEC	A[n] → C[n]
ICSSM2_MUX_SEL	LOW	PRU1 signals mapped to Ethernet PHY	A[n] → B[n]
	HIGH	PRU1 signals mapped to HSEC	A[n] → C[n]

2.12.2.3 LED Indication in RJ45 Connector

The AM263x Control Card has one RJ45 network ports for the ICSSM port on PRU1 of the AM263x SoC. Each RJ45 connector contains two bi-color LEDs that are used to indicate link and activity.

- RJ45 Connector LED indication for the ICSSM PRU1 port:

Table 2-21. ICSSM PRU1 RJ45 Connector LED indication

LED	Color	Indication
Right LED	Green	Ethernet PHY power established
	Yellow	10BT speed link is up
Left LED	Green	Link OK
	Yellow	1000BT speed link is up

2.12.3 I2C

The AM263x Control Card uses three AM263x SoC inter-integrated circuit (I2C) ports to operate as a controller for various targets. TI recommends that all I2C data and clock lines are pulled up to the 3.3V IO voltage supply to enable communication.

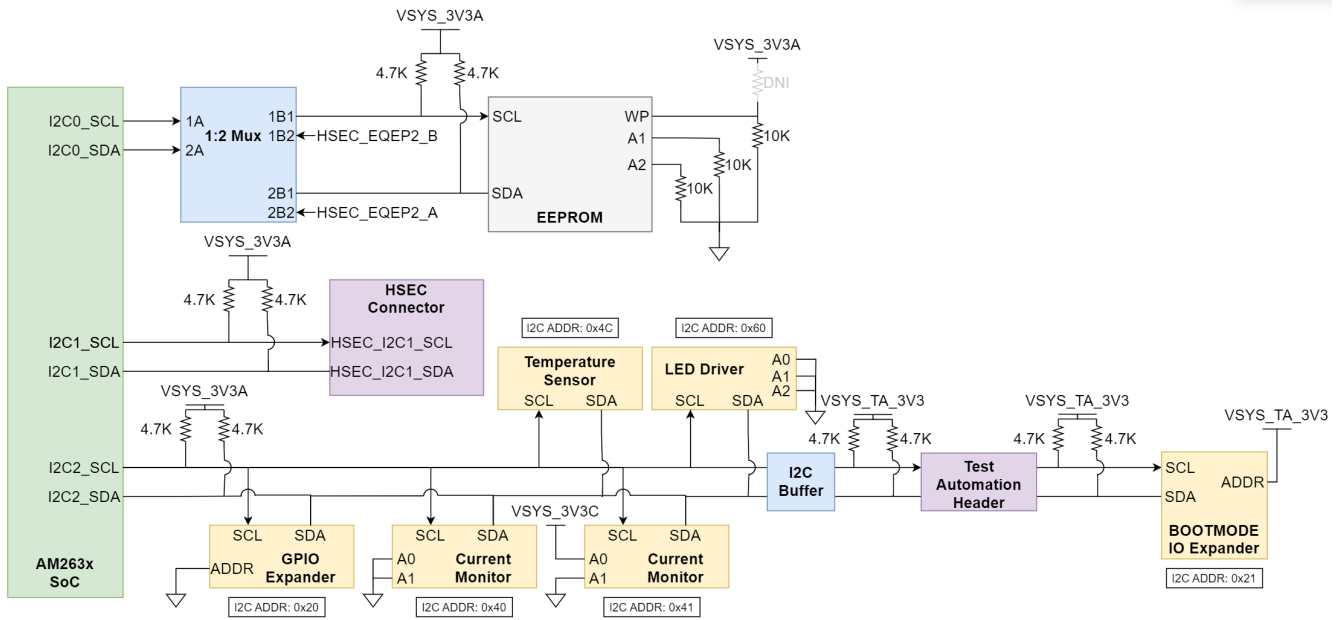

Figure 2-23. I2C Instances Tree

Table 2-22. I2C Addressing

Target	I2C Instance	I2C Address Bit Description	Device Configuration	CC Config.	I2C Address
Board ID EEPROM	I2C0	The first 4 bits of the device address are set to 1010, the next two are set by the A2 and A1 pins, the seventh bit, a16, is the most significant internal address bit	0b10110[A2][A1][a16] A1/A2 are connected to ground	0b <u>1010000</u>	0x50
GPIO Expander	I2C2	The first 6 bits of the target address are set to 010000, the next bit is determined by the addr pin of the IO expander	0b010000[ADDR] ADDR pin connected to ground	0b0 <u>100000</u>	0x20
BOOTMODE IO Expander	I2C2/ I2C1_TA	The first 6 bits of the target address are set to 010000, the next bit is determined by the addr pin of the IO expander	0b010000[ADDR] ADDR pin connected to 3.3V IO supply	0b0 <u>100001</u>	0x21
Current Monitor	I2C2	The first three bits of the target address are 100, the following four bits are determined by what is hooked up to A1 and A0	Refer to Address pin table from Device Data Sheet .	0b <u>1000000</u>	0x40
Current Monitor	I2C2	The first three bits of the target address are 100, the following four bits are determined by what is hooked up to A1 and A0	Refer to Address pin table from Device Data Sheet .	0b <u>1000001</u>	0x41
Temperature Sensor	I2C2	Fixed value of 1001100 for part number TMP411Ax	N/A	0b <u>1001100</u>	0x4C
LED Driver	I2C2	The first four bits of the target address are 1100, the following three are determined by A2, A1, and A0	0b1100[A2][A1][A0] A2/A1/A0 all connected to ground	0b <u>1100000</u>	0x60

Note

Underlined address bits are fixed based on the device addressing and cannot be configured.

2.12.4 Industrial Application LEDs

The AM263x Control Card has an LED driver (TPIC2810D) that is used for Industrial Communication LEDs. The driver is connected to eight green LEDs and has an I2C address of 0x60.

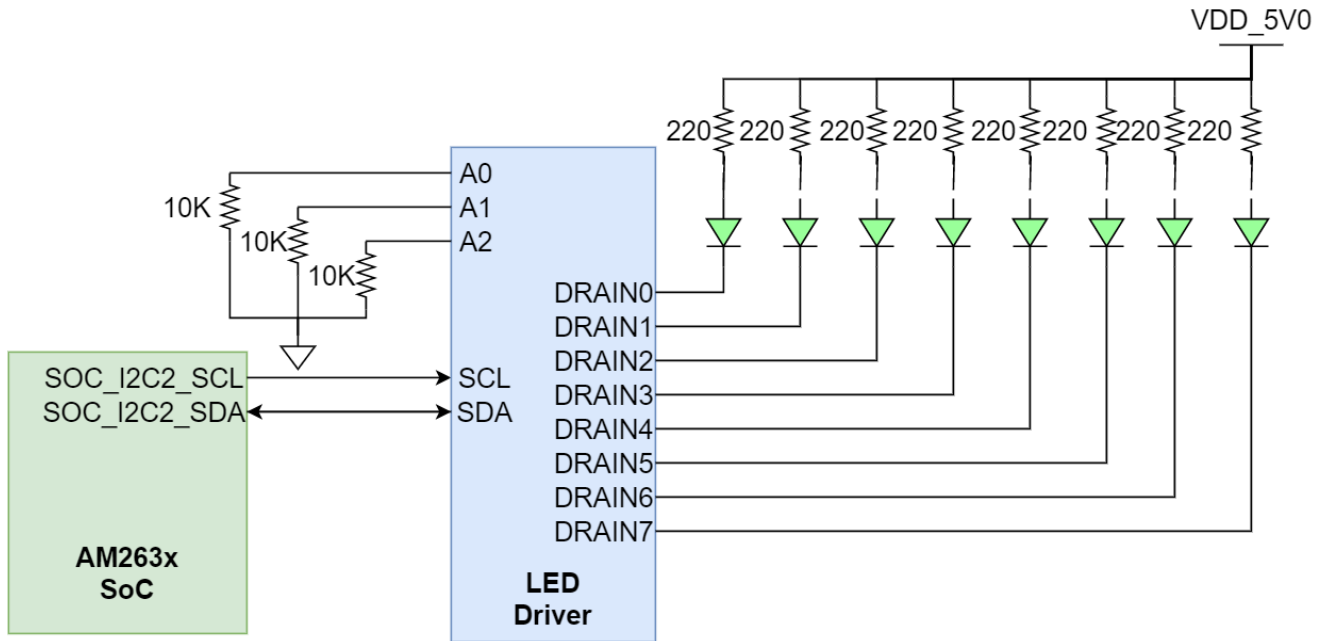

Figure 2-24. Industrial Application LED Driver

2.12.5 SPI

The AM263x Control Card maps two SPI instances (SPI0, SPI1) from the AM263x SoC to the HSEC 180 pin connector. Series termination resistors are placed near the SoC for each SPI clock signal.

There is 4-channel FET Switch that routes SPI1 between the PMIC and the HSEC Connector. This FET Switch has the select line driven by SPI1_MUX_SEL of the IO Expander. Additionally, there is an external pull-down resistor on the Select line, such that the PMIC routing for the SPI signals is in the default state.

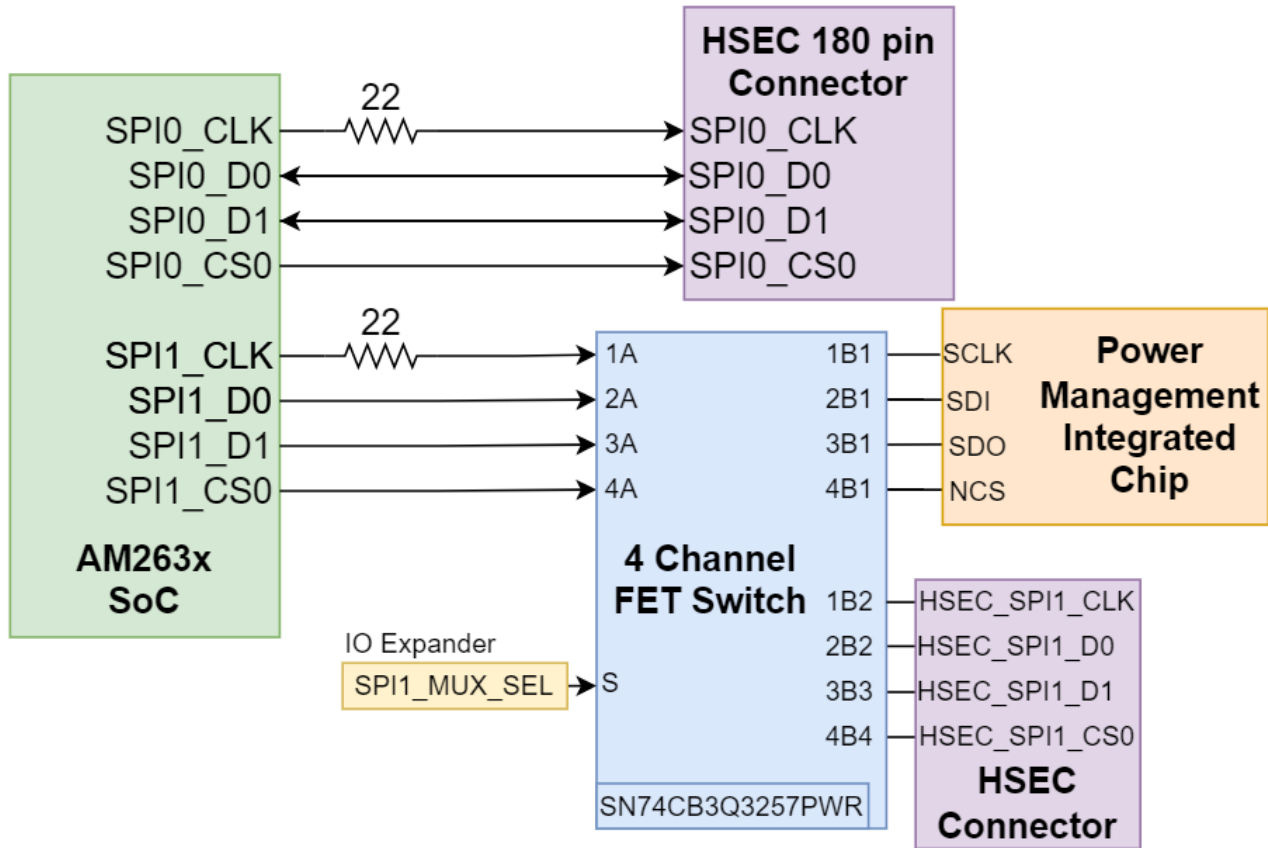

Figure 2-25. SPI

2.12.6 UART

The AM263x Control Card uses the XDS110 as a USB2.0 to UART bridge for terminal access. UART0 transmit and receive signals of the AM263x SoC are mapped to the XDS110 with a dual channel isolation buffer (ISO7221CDR) for translating from the 3.3 V IO voltage supply (VSYS_3V3C) to the 3.3 V XDS supply. The XDS110 is connected to a micro-B USB connector for the USB 2.0 signals. ESD protection is provided to the USB 2.0 signals by a transient voltage suppression device (TPD4E004DRYR). The micro-B USB connector's VBUS 5 V power is mapped to a low dropout regulator (TPS79601DRBR) to generate the 3.3 V XDS supply. A separate 3.3 V supply for the XDS110 allows for the emulator to maintain a connection when power to the Control Card is removed.

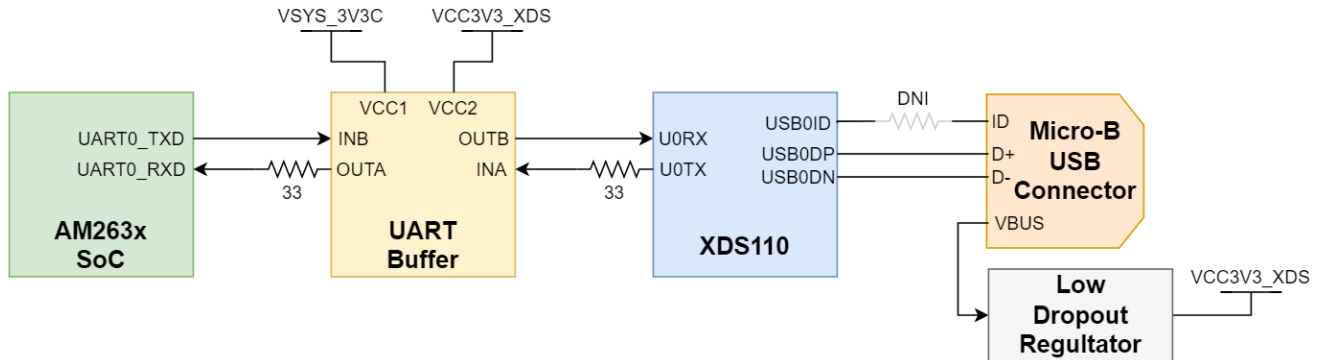

Figure 2-26. UART-USB Bridge for Emulation

The Control Card supports an additional UART1 instance that has the transmit and receive signals mapped from the AM263x SoC to the HSEC connector. To make use of UART1, the select line of a 1:2 mux must be high. The select line is driven by a GPIO signal (LIN_MUX_SEL) that is sourced from the IO expander.

Table 2-23. UART Mux Select Logic

Select	Condition	Function
LOW	LIN Selected	A→B1
HIGH	HSEC UART Selected	A→B2

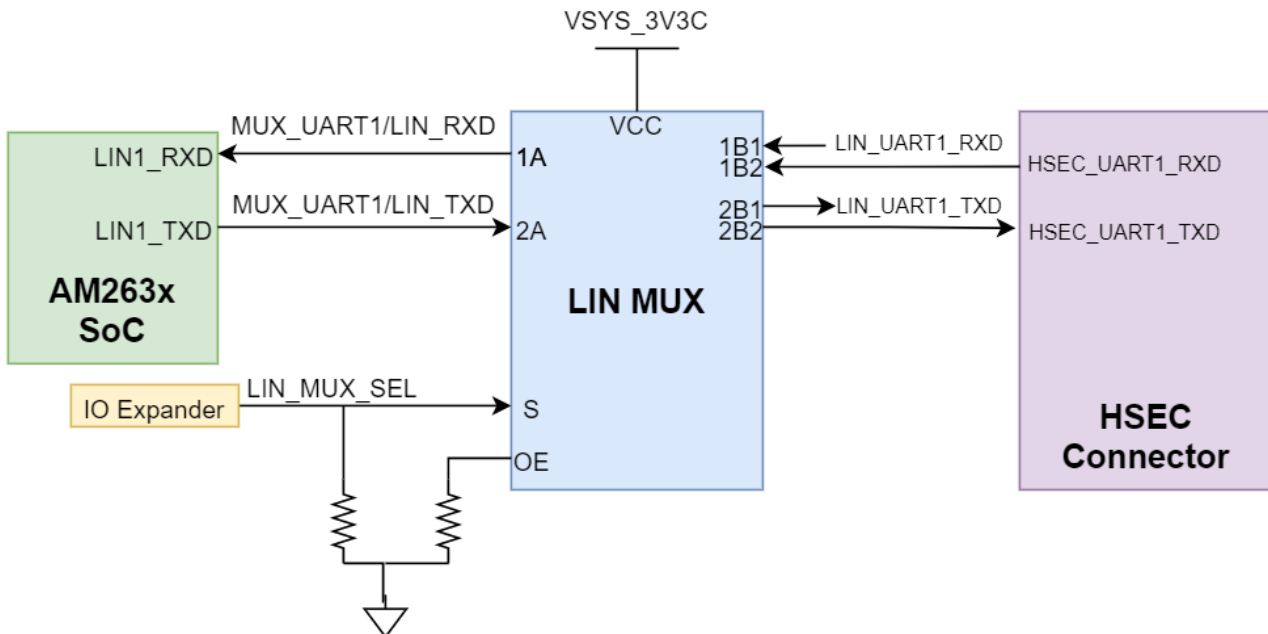

Figure 2-27. UART 1:2 MUX to HSEC

2.12.7 MCAN

The Control Card is equipped with a single MCAN transceiver (TCAN1024H-Q1) that is connected to the MCAN1 interface of the AM263x SoC. The MCAN0 interface of the AM263x SoC is mapped directly to the HSEC connector.

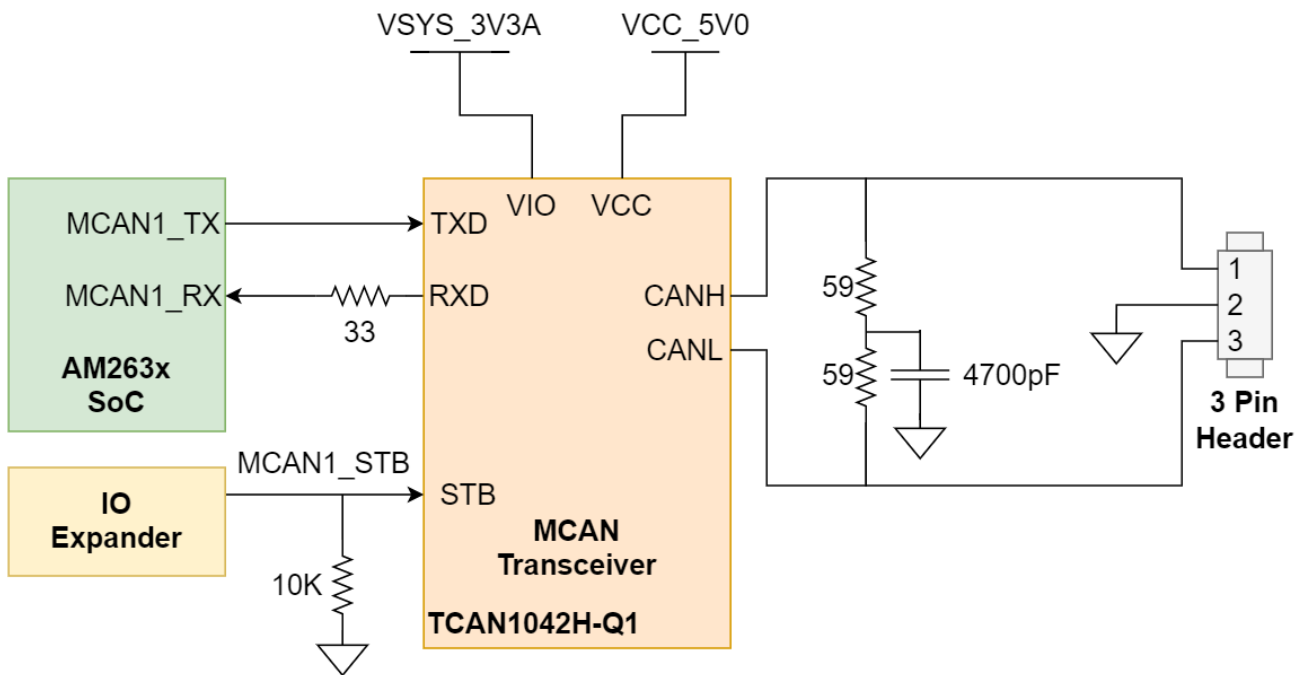

Figure 2-28. MCAN Transceiver

The MCAN transceiver has two power inputs, VIO is the transceiver I/O level shifting supply voltage and VCC is the transceiver 5 V supply voltage. The SoC CAN data transmit data input is mapped to TXD of the transceiver and the CAN receive data output of the transceiver is mapped to the MCAN RX signal of the SoC with a series termination resistor close to the transceiver.

The standby control signal is a GPIO signal sourced from the IO expander. The STB control input is active high and a pull-down resistor is used to have the transceiver operate in normal mode as opposed to the standby mode that is default due to a weak internal pull up.

The system has a 120 Ω split termination on the CANH and CANL signals to improve EMI performance. Split termination improves the electromagnetic emissions behavior of the network by eliminating fluctuations in the bus common-mode voltages at the start and end of message transmissions.

The low- and high-level CAN bus input output lines are terminated to a three pin header.

2.12.8 FSI

The AM263x Control Card supports a fast serial interface by terminating the SoC signals to a 10 pin header. The interface has two lines of data and a clock line for both the receive and transmit signals. The header is connected to the 3.3 V IO voltage supply (VSYS_3V3A).

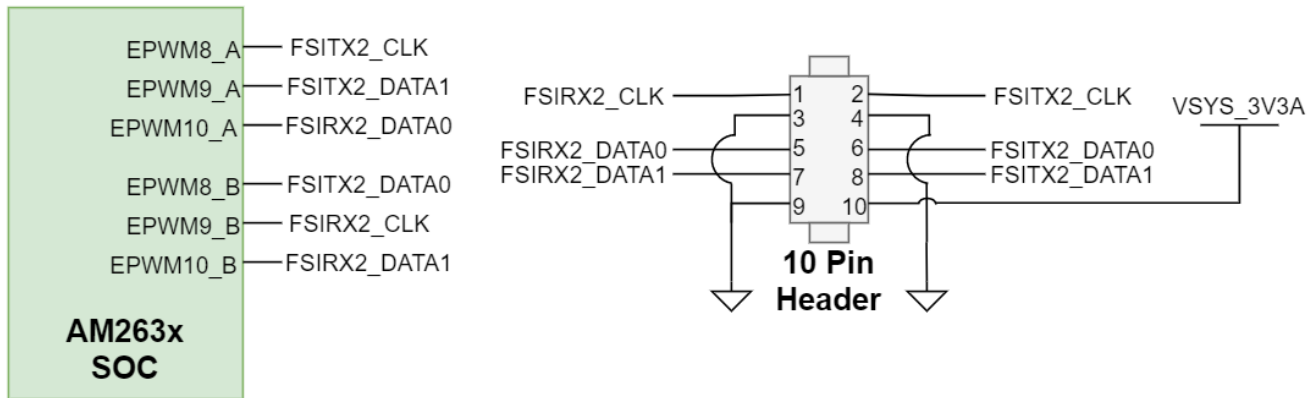

Figure 2-29. FSI Header

2.12.9 JTAG

The AM263x Control Card includes an XDS110 class on-board emulator. The control card also has the option to map the JTAG signals from the AM263x SoC to the HSEC connector.

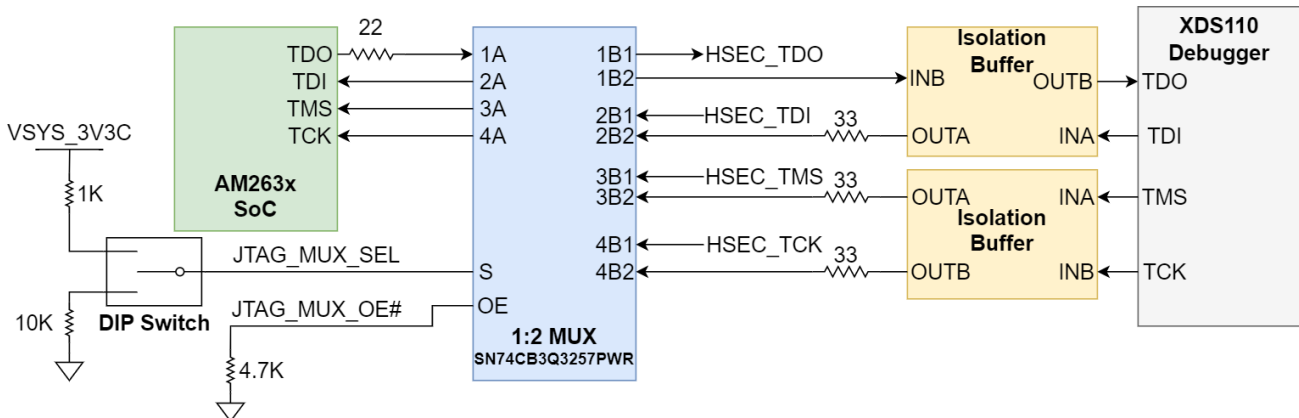

Figure 2-30. JTAG

A DIP switch is used to drive the select line of a 1:2 mux (SN74CB3Q3257PWR) that determines the path of the AM263x SoC JTAG signals. [Figure 2-31](#) shows JTAG path selection for either switch position.

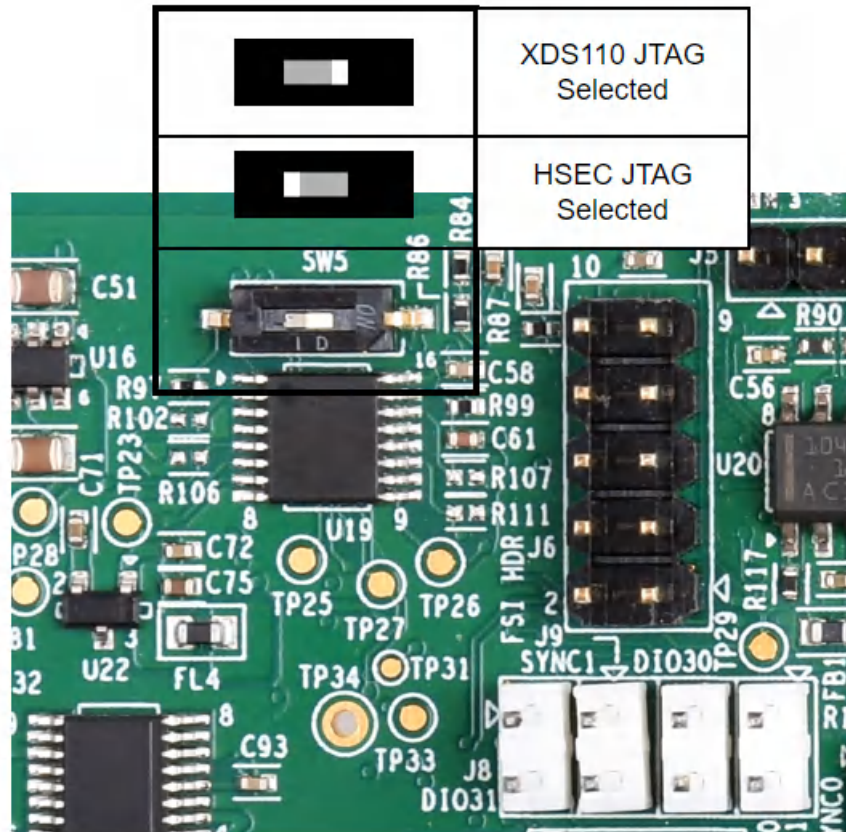

Figure 2-31. JTAG Path Switch Position

The Control Card includes all circuitry needed for XDS110 emulation. The emulator uses a USB 2.0 micro-B connector to interface the USB 2.0 signals that are created from the UART-USB bridge. The VBUS power from the connector is used to power the emulation circuit so that the connection to the emulator is not lost when power to the Control Card is removed.

The XDS110 controls two power status LED's. For more information refer to [Section 2.3.2](#).

2.12.10 Test Automation Header

The AM263x Control Card supports a 40-pin test automation header that allows an external controller to manipulate basic operations such as power down, PORz, warm reset, and bootmode control.

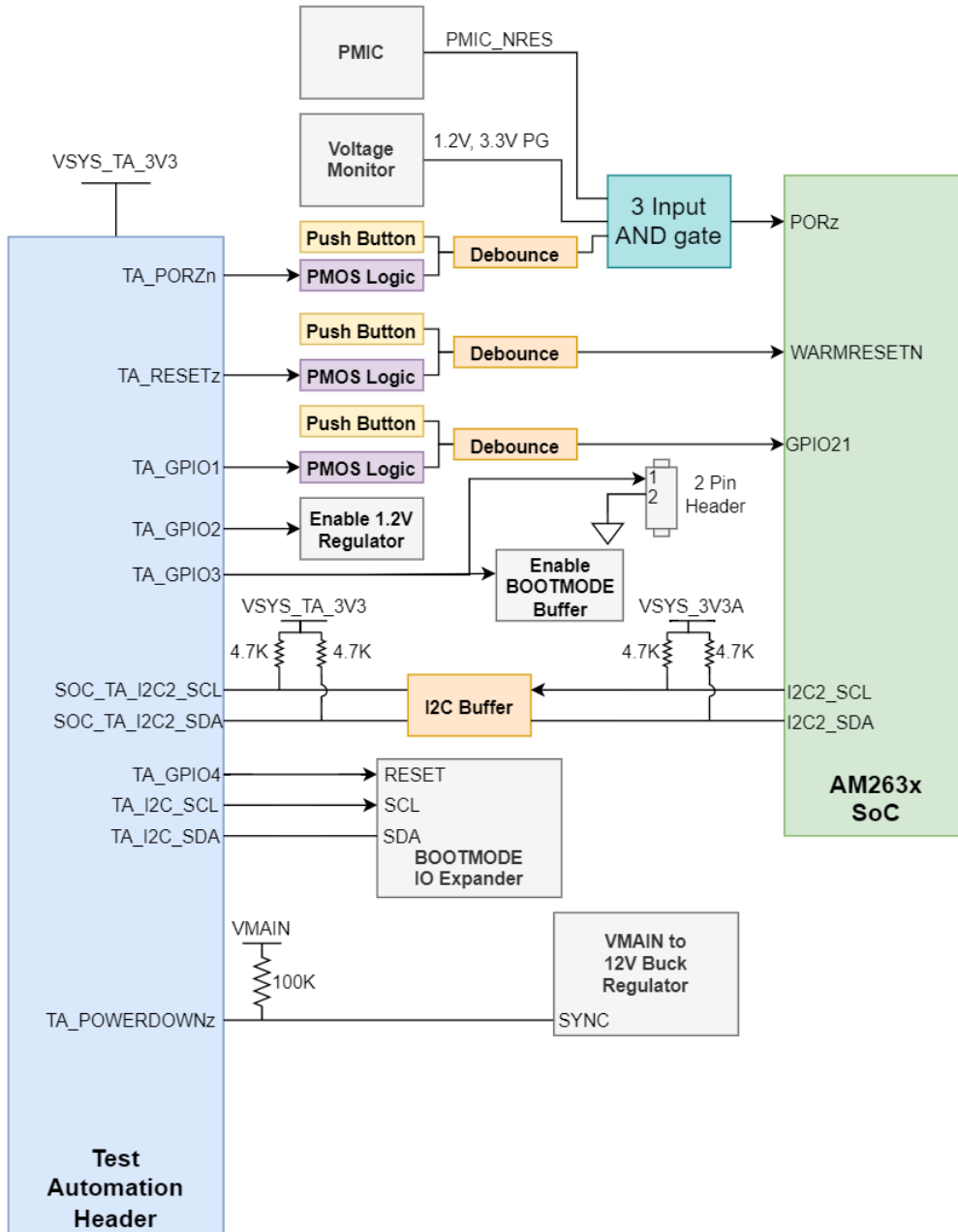

Figure 2-32. Test Automation Header

The Test Automation Circuit is powered by a dedicated 3.3 V power supply (VSYS_TA_3V3) that is generated by a 5 V to 3.3 V buck regulator (TPS62177DQCR).

The AM263x SoC I2C2 instance is connected to both the Test Automation Header and the bootmode IO expander (TCA6408ARGTR).

[Test Automation Header GPIO Mapping](#) details the Test Automation GPIO mapping:

Table 2-24. Test Automation Header GPIO Mapping

Signal Name	Description	Direction
TA_POWERDOWN	When logic low, disables the 3.3 V buck regulator (TPS62913RPUR) that is used in the first stage of DC/DC conversion	Output
TA_PORZn	When logic low, connects the PORz signal to ground due to the PMOS V_GS being less than zero creating a power on reset to the MAIN domain	Output
TA_RESEZ	When logic low, connects the WARMRESETn signal to ground due to the PMOS V_GS being less than zero creating a warm reset to the MAIN domain	Output
TA_GPIO1	When logic low, connects the INTn signal to ground due to the PMOS V_GS being less than zero creating an interrupt to the SoC	Output
TA_GPIO2	When logic low, disables the 1.2 V buck regulator (TPS62913RPUR)	Output
TA_GPIO3	When logic low, disables the bootmode buffer output enable	Output
TA_GPIO4	Reset signal for Bootmode IO Expander (TCA6408ARGTR)	Output

2.12.11 LIN

The AM263x Control Card supports Local Interconnect Network communication through the use of a LIN transceiver (TLIN2029-Q1) that outputs the LIN Bus to the second pin of a 3 pin header.

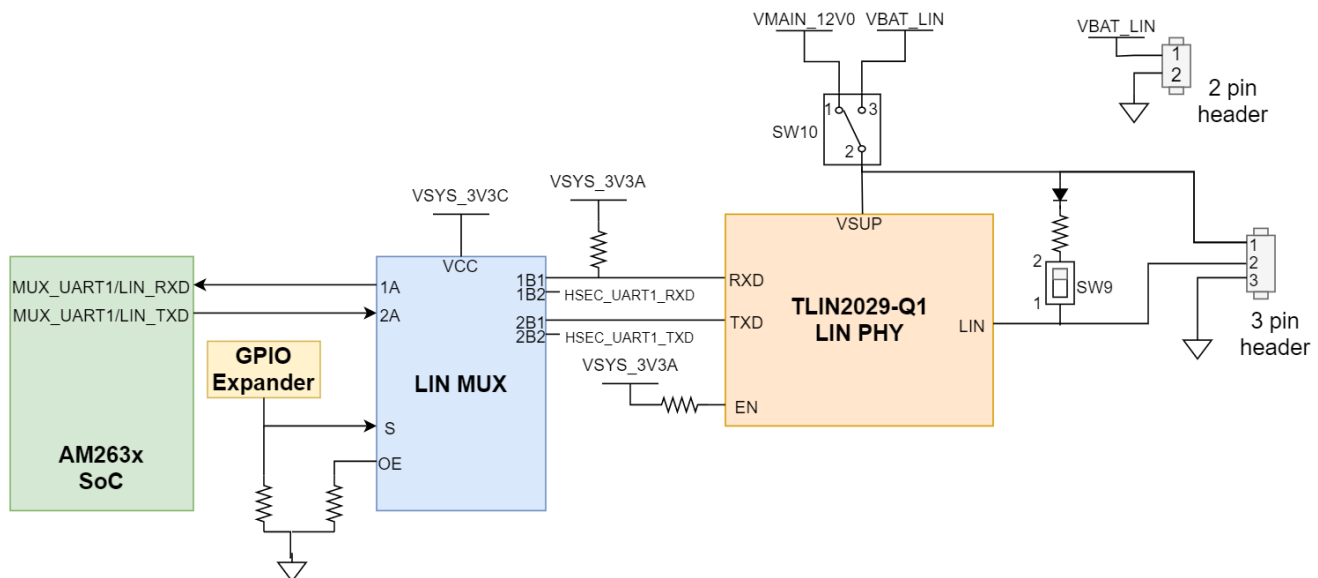

Figure 2-33. LIN PHY

The LIN transmit and receive signals are internally muxed on the AM263x with the UART1 transmit and receive signals. Because of the internal muxing, there is an external 1:2 mux (SN74CB3Q3257PWR) which has a select line that is driven by the GPIO Expander.

Table 2-25. LIN MUX Select Logic

Select Logic	Condition	Function
LOW	LIN Selected	A→B1
HIGH	HSEC UART Selected	A→B2

The AM263x SoC does not have an integrated pull up for the LIN RX signal, therefore, an external pull up resistor is needed to the processor I/O supply voltage is required.

The AM263x Control Card includes a double pole single throw switch (SW10) to control the voltage supply for the LIN Transceiver.

Table 2-26. LIN Switch Logic

LIN Voltage Switch Position	Voltage Supply Selected
Pin 1-2	VMAIN, 5 V supply output from either the USB-C connection or HSEC power connection.
Pin 2-3	VBAT_LIN, external voltage supply from pin 1 of 2 pin header

There is also a single pole throw switch (SW9) that drives the LIN Node application.

Table 2-27. LIN Node Application Switch

LIN Node Application Switch Position	LIN Node Application
Pin 1	Device node application
Pin 2	Controller node application

The Control Card pulls up the enable pin of the LIN transceiver for the transceiver to be in normal operational mode when the I/O Voltage supply is brought up.

2.12.12 MMC

The AM263x Control Card provides a micro SD card interface that is mapped to the MMC0 instance of the AM263x SoC.

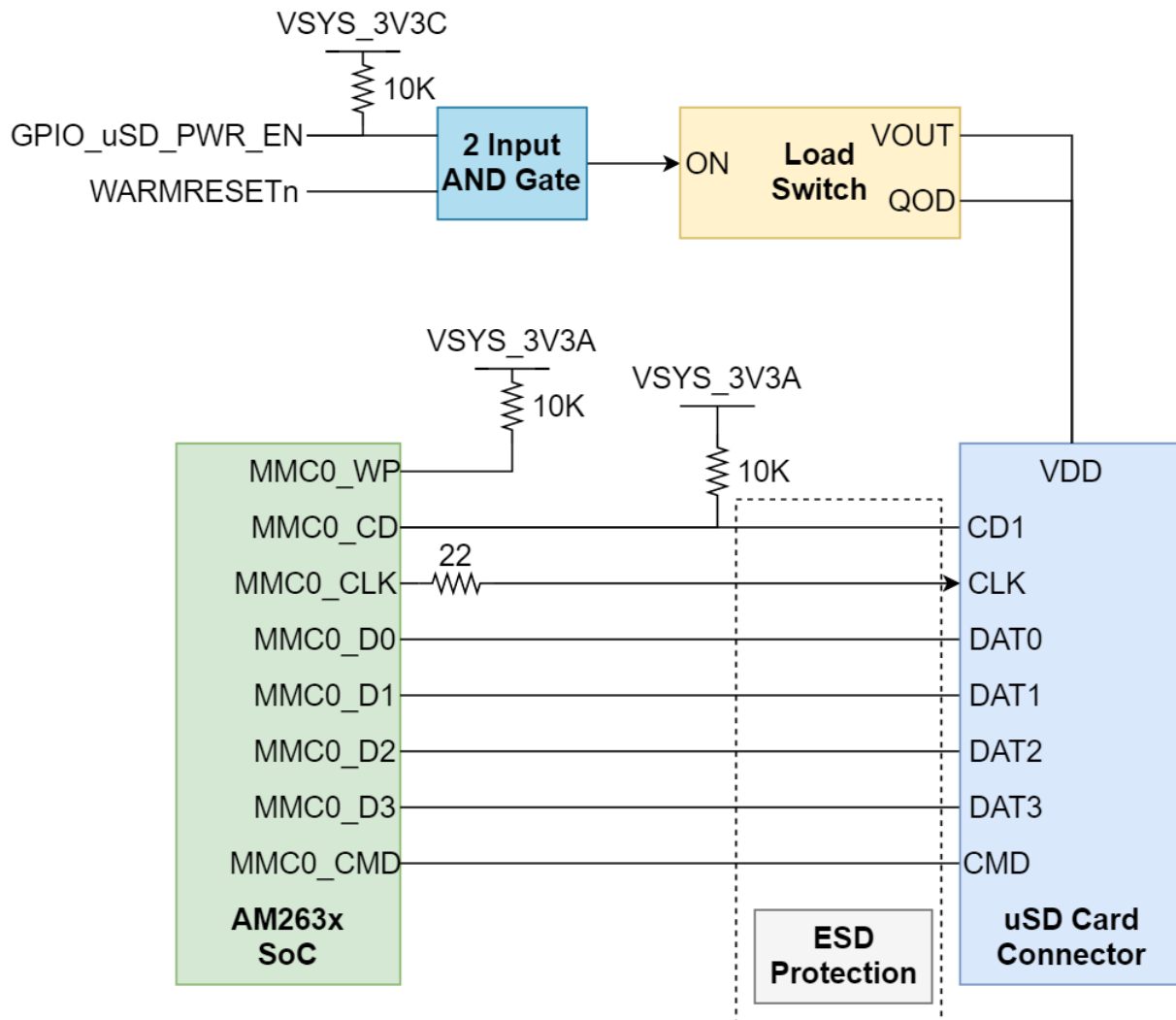

Figure 2-34. Micro-SD Connector Interface

A load switch (TPS22918DBVR) is used to power the micro SD card connector. The load switch is driven by the output of a 2-input AND gate between WARMRESETn and GPIO_uSD_PWR_EN to power cycle the card upon reset. The load switch uses quick output discharge (QOD) to make sure that the supply voltage reaches <10% of nominal value during reset.

Inline ESD protection is provided for the MMC signals in the form of a six channel transient voltage suppressor device (TPD6E001RSER).

The Write Protect (WP) and Card Detect (CD) signals of the SD card connector are pulled up to the 3.3 V IO voltage supply.

A series termination resistor is provided for the MMC clock signal.

2.12.13 ADC and DAC

The AM263x Control Card supports 24 ADC signal channels that are mapped for the AM263x SoC and terminated to the HSEC connector. All ADC signals are ESD protected (TPD4E001DBVR).

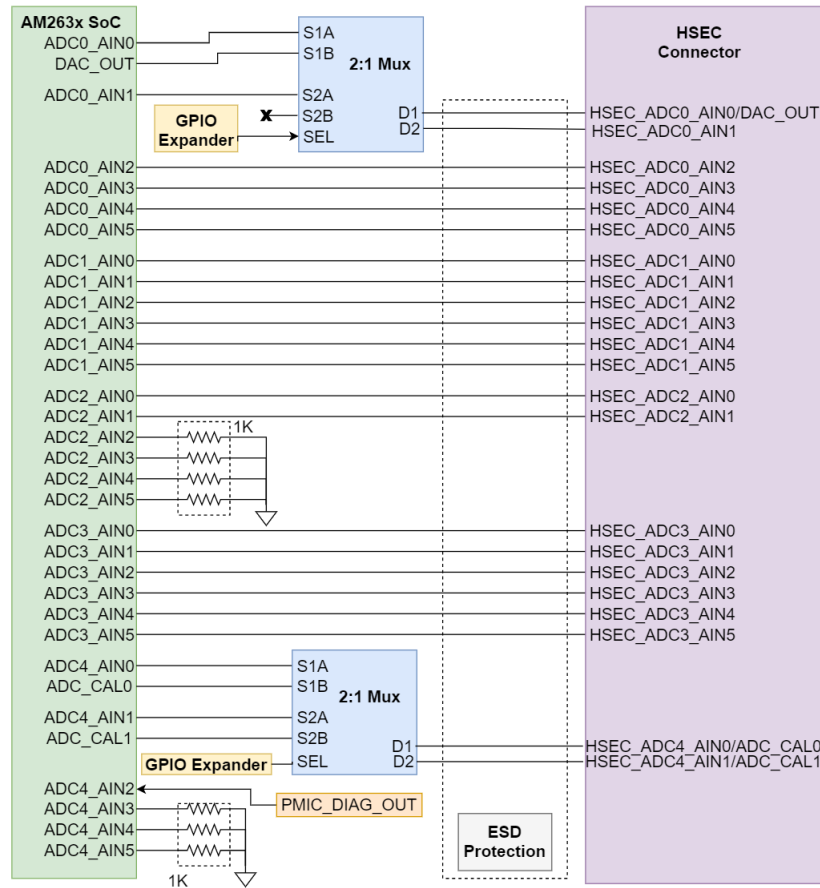

Figure 2-35. ADC HSEC Connections

There are two muxes (TMUX1136DQAR) that determine the pathing of ADC signals to and from the HSEC Connector.

Table 2-28. ADC MUX Select Logic

MUX Select Signal	Condition	Function	Description
ADC1_MUX_SEL	SEL Signal HIGH	S1A → D1	HSEC_ADC0_AIN0 selected
		S2A → D2	HSEC_ADC0_AIN1 selected
	SEL Signal LOW	S1B → D1	HSEC_DAC_OUT selected
		S2B → D2	HSEC_DAC_OUT selected
ADC2_MUX_SEL	SEL Signal HIGH	S1A → D1	HSEC_ADC4_AIN0 selected
		S2A → D2	HSEC_ADC4_AIN1 selected
	SEL Signal LOW	S1B → D1	ADC_CAL0 selected
		S2B → D2	ADC_CAL1 selected

There are three switches that are used to configure the reference voltages for the ADC and DAC.

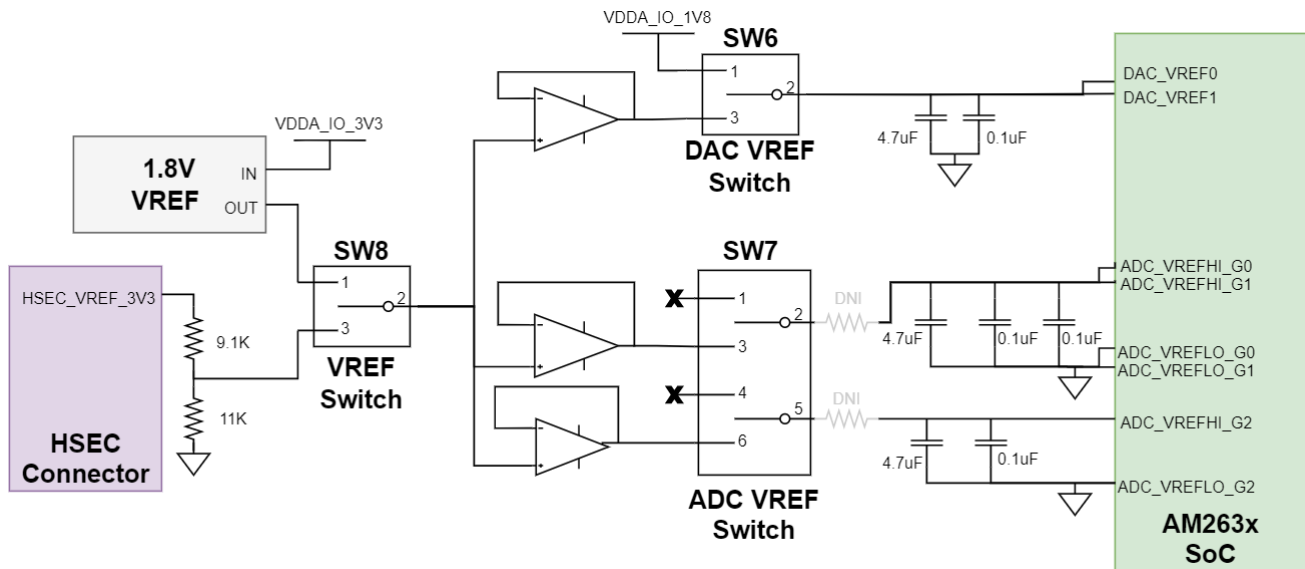

Figure 2-36. ADC Switch Routing

- The VREF Switch (SW8) is a single pole double throw switch that controls which 1.8 V reference is used for ADC and DAC.

Table 2-29. VREF Switch

VREF Switch Position	Reference Selection
Pin 1-2	On board 1.8 V Reference (REF3318AIDBZT)
Pin 2-3	HSEC VREF

- The DAC VREF Switch (SW6) is a single pole double throw switch that controls the input for the DAC VREF inputs of the AM263x SoC.

Table 2-30. DAC VREF Switch

DAC VREF Switch Position	Reference Selection
Pin 1-2	AM263x on-die LDO
Pin 2-3	Output of VREF Switch

- The ADC VREF Switch (SW7) contains two single pole double throw switches that control the input for the ADC VREF inputs of the AM263x SoC.

Table 2-31. ADC VREF Switch

ADC VREF Switch Position	Reference Selection
Pin 1-2	OPEN - Allow for reference to be AM263x on-die LDO reference
Pin 2-3	Output of VREF Switch
Pin 4-5	OPEN - Allow for reference to be AM263x on-die LDO reference
Pin 5-6	Output of VREF Switch

2.13 HSEC Pinout and Pinmux Mapping

Table 2-32 shows the pinout of the 180 High-Speed Edge Connector and all available pinmux options for each pin. Table 2-33 shows all AM263x balls and the available pinmux mode options for each ball.

Table 2-32. HSEC Pinout

Pin #	Package Signal Name	Muxed Signal Options	Muxed Signal Options	Signal Package Name	Pin #
1	NC	NC	NC	NC	2
3	HSEC_TMS	TMS	NC	NC	4
5	HSEC_TCK	TCK	TDO	HSEC_TDO	6
7	GND	GND	TDI	HSEC_TDI	8
9	HSEC_ADC0_AIN4/ DAC_OUT	HSEC_ADC0_AIN0/DAC_OUT	GND	GND	10
11	HSEC_ADC0_AIN5/ DAC_OUT	HSEC_ADC0_AIN1/DAC_OUT	ADC1_AIN0	ADC1_AIN0	12
13	GND	GND	ADC1_AIN1	ADC1_AIN1	14
15	ADC0_AIN2	ADC0_AIN2	GND	GND	16
17	ADC0_AIN3	ADC0_AIN3	ADC1_AIN2	ADC1_AIN2	18
19	GND	GND	ADC1_AIN3	ADC1_AIN3	20
21	ADC0_AIN4	ADC0_AIN4	GND	GND	22
23	ADC0_AIN5	ADC0_AIN5	ADC1_AIN4	ADC1_AIN4	24
25	ADC4_AIN0/ADC_CAL0	ADC4_AIN0/ADC_CAL0	ADC1_AIN5	ADC1_AIN5	26
27	ADC4_AIN1/ADC_CAL1	ADC4_AIN1/ADC_CAL1	ADC3_AIN0	ADC3_AIN0	28
29	GND	GND	ADC3_AIN1	ADC3_AIN1	30
31	ADC2_AIN0	ADC2_AIN0	GND	GND	32
33	ADC2_AIN1	ADC2_AIN1	ADC3_AIN2	ADC3_AIN2	34
35	GND	GND	ADC3_AIN3	ADC3_AIN3	36
37	ADC2_AIN2	ADC2_AIN2	GND	GND	38
39	ADC2_AIN3	ADC2_AIN3	ADC3_AIN4	ADC3_AIN4	40
41	NC	NC	ADC3_AIN5	ADC3_AIN5	42
43	NC	NC	NC	NC	44
45	HSEC_ADC-VREFHI	HSEC_ADC-VREFHI	GND	GND	46
47	GND	GND	HSEC_5V0	HSEC_5V0	48
49	EPWM0_A	EPWM0_A/GPIO43	EPWM2_A/GPIO47	EPWM2_A	50
51	EPWM0_B	EPWM0_B/GPIO44	EPWM2_B/GPIO48	EPWM2_B	52
53	EPWM1_A	EPWM1_A/GPIO45	EPWM3_A/GPIO49	EPWM3_A	54
55	EPWM1_B	EPWM1_B/GPIO46	EPWM3_B/GPIO50	EPWM3_B	56
57	EPWM4_A	EPWM4_A/GPIO51	EPWM6_A/FSIRX1_CLK/GPIO55	EPWM6_A	58
59	EPWM4_B	EPWM4_B/FSITX1_CLK/GPIO52	EPWM6_B/FSIRX1_DATA0/GPIO56	EPWM6_B	60
61	EPWM5_A	EPWM5_A/FSITX1_DATA0/GPIO53	EPWM7_A/FSIRX1_DATA1/GPIO57	EPWM7_A	62
63	EPWM5_B	EPWM5_B/FSITX1_DATA1/GPIO54	EPWM7_B/GPIO58	EPWM7_B	64
65	GND	GND	NC	NC	66
67	SPI0_D0	SPI0_D0/FSITX0_DATA0/GPIO13/SOP3	PR0_PRU1_GPO19/UART3_RXD/PR0_IEP0_EDC_SYNC_OUT0/TRC_CLK/ XBAROUT13/GPIO119/EQEP1_A	EQEP1_A	68

Table 2-32. HSEC Pinout (continued)

Pin #	Package Signal Name	Muxed Signal Options	Muxed Signal Options	Signal Package Name	Pin #
69	SPI0_D1	SPI0_D1/FSITX0_DATA1/GPIO14	PR0_PRU1_GPO18/UART3_TXD/PR0_IEP0_EDIO_DATA_IN_OUT31/TRC_CTL/ XBAROUT14/GPMC0_WAIT1/GPIO120/EQEP1_B	EQEP1_B	70
71	SPI0_CLK	SPI0_CLK/UART3_TXD/LIN3_TXD/FSITX0_CLK/GPIO12/SOP2	SDFM0_CLK0/CLKOUT1/GPIO122/EQEP1_STROBE	EQEP1_STROBE	72
73	SPI0_CS0	SPI0_CS0/UART3_RXD/LIN3_RXD/GPIO11	EXT_REFCLK0/XBAROUT15/GPIO121/EQEP1_INDEX	EQEP1_INDEX	74
75	SPI1_D0	SPI1_D0/UART5_TXD/XBAROUT3/FSIRX0_DATA0/GPIO17	LIN1_RXD/UART1_RXD/SPI2_CS0/XBAROUT5/GPIO19	UART1_RXD	76
77	SPI1_D1	SPI1_D1/UART5_RXD/XBAROUT4/FSIRX0_DATA1/GPIO18	LIN1_TXD/UART1_TXD/SPI2_CLK/XBAROUT6/GPIO20	UART1_TXD	78
79	SPI1_CLK	SPI1_CLK/UART4_RXD/LIN4_RXD/XBAROUT2/FSIRX0_CLK/GPIO16	MCAN0_RX/SPI4_CS0/GPIO7	MCAN0_RX	80
81	SPI1_CS0	SPI1_CS0/UART4_TXD/LIN4_TXD/XBAROUT1/GPIO15	MCAN0_TX/SPI4_CLK/GPIO8	MCAN0_TX	82
83	GND	GND	HSEC_5V0	HSEC_5V0	84
85	I2C1_SDA	I2C1_SDA/SPI3_CLK/XBAROUT8/GPIO24	EPWM11_A/UART2_CTSn/GPMC0_CLKLB/GPIO65	GPMC0_CLKB	86
87	I2C1_SCL	I2C1_SCL/SPI3_CS0/XBAROUT7/GPIO23	NC	NC	88
89	EPWM21_A	PR0_MDIO0_MDIO/EPWM21_A/GPMC0_CSn2/GPIO85	PR0_MDIO0_MDC/EPWM21_B/GPMC0_CSn3/GPIO86	EPWM21_B	90
91	SDFM0_D0	SDFM0_D0/PR0_ECAP0_APWM_OUT/GPIO123	I2C0_SDA/GPIO134/EQEP2_A/SDFM1_CLK2	EQEP2_A	92
93	EQEP2_B	I2C0_SCL/GPIO135/EQEP2_B/SDFM1_CLK3	MCAN2_RX/UART2_RTSn/GPIO137/EQEP2_INDEX/SDFM1_D3	EQEP2_INDEX	94
95	EQEP2_STROBE	MCAN2_TX/UART1_RTSn/GPIO136/EQEP2_STROBE/SDFM1_D2	NC	NC	96
97	GND	GND	HSEC_5V0	HSEC_5V0	98
99	SDFM0_D1	SDFM0_D1/PR0_PRU1_GPIO17/UART5_CTSn/ PR0_IEP0_EDIO_DATA_IN_OUT30/GPIO125	EQEP0_A/UART4_RTSn/SPI4_CLK/GPIO130/SDFM1_CLK0	EQEP0_B	100
101	SDFM0_CLK1	SDFM0_CLK1/PR0_PRU1_GPIO7/CPTS0_TS_SYNC/UART5_RTSn/ PR0_IEP0_EDC_SYNC_OUT1/I2C3_SDA/GPIO124	EQEP0_B/UART4_CTSn/SPI4_CS0/GPIO131/SDFM1_D0	EQEP0_A	102
103	SDFM0_D2	SDFM0_D2/UART5_RXD/GPIO127	EQEP0_STROBE/UART4_TXD/LIN4_TXD/SPI4_D0/GPIO132/SDFM1_CLK1	EQEP0_STROBE	104
105	SDFM0_CLK2	SDFM0_CLK2/UART5_TXD/I2C3_SCL/GPMC0_ADVn_ALE/GPIO126/ SDFM0_CLK2	EQEP0_INDEX/UART4_RXD/LIN4_RXD/SPI4_D1/GPIO133/SDFM1_D1	EQEP0_INDEX	106
107	SDFM0_D3	SDFM0_D3/MCAN3_RX/GPIO129	PR0_PRU0_GPO5/RMII2_RX_ER/MII2_RX_ER/EPWM22_A/GPMC0_DIR/ GPIO87	MII0_RXER	108
109	SDFM0_CLK3	SDFM0_CLK3/MCAN3_TX/UART5_RXD/GPIO128	PR0_PRU0_GPO9/PR0_UART0_CTSn/MII2_COL/EPWM22_B/GPMC0_CLK/ GPIO88	MII0_CO	110
111	GND	GND	HSEC_5V0	HSEC_5V0	112
113	NC	NC	NC	NC	114
115	NC	NC	NC	NC	116
117	NC	NC	HSEC_5V0	HSEC_5V0	118
119	NC	NC	PORz	PORz	120
121	ICSS_MII0_CRS	PR0_PRU0_GPO10/RMII2_CRS_DV/PR0_UART0_RTSn/MII2_CRS/EPWM23_A/ GPMC0_WAIT0/GPIO89	PR0_PRU0_GPO8/EPWM23_B/GPMC0_WPn/GPIO90	ICSS_MII0_RXLINK	122
123	ICSS_MII0_RXCLK	PR0_PRU0_GPO6/RMII2_REF_CLK/RGMII2_RXC/MII2_RXCLK/EPWM24_A/ GPMC0_CSn1/GPIO91	PR0_PRU0_GPO4/RGMII2_RX_CTL/MII2_RXDV/EPWM24_B/GPMC0_A0/ GPIO92	ICSS_MII0_RXDV	124
125	ICSS_MII0_RXD0	PR0_PRU0_GPO0/RMII2_RXD0/RGMII2_RD0/MII2_RXD0/EPWM25_A/ GPMC0_A1/GPIO93	PR0_PRU0_GPO1/RMII2_RXD1/RGMII2_RD1/MII2_RXD1/EPWM25_B/ GPMC0_A2/GPIO94	ICSS_MII0_RXD1	126
127	ICSS_MII0_RXD2	PR0_PRU0_GPO2/RGMII2_RD2/MII2_RXD2/EPWM26_A/GPMC0_A3/GPIO95	PR0_PRU0_GPO3/RGMII2_RD3/MII2_RXD3/EPWM26_B/GPMC0_A4/GPIO96	ICSS_MII0_RXD3	128
129	ICSS_MII0_TXCLK	PR0_PRU0_GPO16/RGMII2_TXC/MII2_TXCLK/EPWM27_A/GPMC0_A5/GPIO97	PR0_PRU0_GPO15/RMII2_TX_EN/RGMII2_TX_CTL/MII2_TX_EN/EPWM27_B/ GPMC0_A6/GPIO98	ICSS_MII0_TXEN	130
131	ICSS_MII0_TXD0	PR0_PRU0_GPO11/RMII2_TXD0/RGMII2_TD0/MII2_TXD0/EPWM28_A/ GPMC0_A7/GPIO99	PR0_PRU0_GPO12/RMII2_TXD1/RGMII2_TD1/MII2_TXD1/EPWM28_B/ GPMC0_A8/GPIO100	ICSS_MII0_TXD1	132
133	ICSS_MII0_TXD2	PR0_PRU0_GPO14/RGMII2_TD3/MII2_TXD3/EPWM29_B/GPMC0_A10/ GPIO102	PR0_PRU0_GPO14/RGMII2_TD3/MII2_TXD3/EPWM29_B/GPMC0_A10/ GPIO102	ICSS_MII0_TXD3	134

Table 2-32. HSEC Pinout (continued)

Pin #	Package Signal Name	Muxed Signal Options	Muxed Signal Options	Signal Package Name	Pin #
135	GND	GND	NC	NC	136
137	ICSS_MII1_RXER	PR0_PRU1_GPO5/TRC_DATA0/EPWM30_A/GPMC0_OEn_REn/GPIO103	PR0_PRU1_GPO9/PR0_UART0_RXD/TRC_DATA1/EPWM30_B/GPMC0_BE0n_CLE/GPIO104	ICSS_MII1_COL	138
139	ICSS_MII1_CRS	PR0_PRU1_GPO10/PR0_UART0_TXD/TRC_DATA2/EPWM31_A/GPMC0_BE1n/GPIO105	PR0_PRU1_GPO8/TRC_DATA3/EPWM31_B/GPMC0_WEn/GPIO106	ICSS_MII1_RXLINK	140
141	ICSS_MII1_RXCLK	PR0_PRU1_GPO6/FSITX2_CLK/TRC_DATA4/GPMC0_A11/GPIO107	PR0_PRU1_GPO4/FSITX2_DATA0/TRC_DATA5/GPMC0_A12/GPIO108	ICSS_MII1_RXDV	142
143	ICSS_MII1_RXD0	PR0_PRU1_GPO0/FSITX2_DATA1/TRC_DATA6/GPMC0_A13/GPIO109	PR0_PRU1_GPO1/FSIRX2_CLK/TRC_DATA7/GPMC0_A14/GPIO110	ICSS_MII1_RXD1	144
145	ICSS_MII1_RXD2	PR0_PRU1_GPO2/FSIRX2_DATA0/TRC_DATA8/GPMC0_A15/GPIO111	PR0_PRU1_GPO3/FSIRX2_DATA1/TRC_DATA9/GPMC0_A16/GPIO112	ICSS_MII1_RXD3	146
147	ICSS_MII1_TXCLK	PR0_PRU1_GPO16/FSITX3_CLK/TRC_DATA10/GPMC0_A17/GPIO113	PR0_PRU1_GPO15/FSITX3_DATA0/TRC_DATA11/GPMC0_A18/GPIO114	ICSS_MII1_TXEN	148
149	ICSS_MII1_TXD0	PR0_PRU1_GPO11/FSITX3_DATA1/TRC_DATA12/GPMC0_A19/GPIO115	PR0_PRU1_GPO12/FSIRX3_CLK/TRC_DATA13/GPMC0_A20/GPIO116	ICSS_MII1_TXD1	150
151	ICSS_MII1_TXD2	PR0_PRU1_GPO13/FSIRX3_DATA0/TRC_DATA14/XBAROUT11/GPMC0_A21/GPIO117	PR0_PRU1_GPO14/FSIRX3_DATA1/TRC_DATA15/XBAROUT12/GPMC0_CSn0/GPIO118	ICSS_MII1_TXD3	152
153	GPMC0_AD0	EPWM13_A/UART1_RIn/GPMC0_AD0/GPIO69	EPWM13_B/UART1_DTRn/GPMC0_AD1/GPIO70	GPMC0_AD1	154
155	GPMC0_AD2	EPWM14_A/UART1_DSRn/GPMC0_AD2/GPIO71	EPWM14_B/MII1_RX_ER/GPMC0_AD3/GPIO72	GPMC0_AD3	156
157	GND	GND	HSEC_5V0	HSEC_5V0	158
159	GPMC0_AD4	EPWM15_A/UART5_TXD/MII1_COL/GPMC0_AD4/GPIO73	EPWM15_B/UART5_RXD/MII1_CRS/GPMC0_AD5/GPIO74	GPMC0_AD5	160
161	GPMC0_AD6	UART1_RXD/LIN1_RXD/EPWM16_A/GPMC0_AD6/GPIO75	UART1_TXD/LIN1_TXD/EPWM16_B/GPMC0_AD7/GPIO76	GPMC0_AD7	162
163	GPMC0_AD8	MMC0_CLK/UART0_RXD/LIN0_RXD/EPWM17_A/GPMC0_AD8/GPIO77/SDFM1_CLK0	MMC0_CMD/UART0_TXD/LIN0_TXD/EPWM17_B/GPMC0_AD9/GPIO78/SDFM1_D0	GPMC0_AD9	164
165	GPMC0_AD10	MMC0_D0/UART2_RXD/I2C1_SCL/EPWM18_A/GPMC0_AD10/GPIO79/SDFM1_CLK1	MMC0_D1/EPWM18_B/GPMC0_AD11/GPIO80/SDFM1_D1	GPMC0_AD11	166
167	GPMC0_AD12	MMC0_D2/UART2_TXD/I2C1_SDA/EPWM19_A/GPMC0_AD12/GPIO81/SDFM1_CLK2	MMC0_D3/UART3_RTSn/EPWM19_B/GPMC0_AD13/GPIO82/SDFM1_D2	GPMC0_AD13	168
169	GPMC0_AD14	MMC0_WP/UART0_RTSn/I2C2_SCL/EPWM20_A/GPMC0_AD14/GPIO83/SDFM1_CLK3	MMC0_CD/UART0_CTSn/I2C2_SDA/EPWM20_B/GPMC0_AD15/GPIO84/SDFM1_D3	GPMC0_AD15	170
171	NC	NC	NC	NC	172
173	NC	NC	NC	NC	174
175	NC	NC	NC	NC	176
177	NC	NC	NC	NC	178
179	GND	GND	HSEC_5V0	HSEC_5V0	180

Table 2-33. Pinmux Mapping Table

Pin#	Pinlist	Mode0	Mode1	Mode2	Mode3	Mode4	Mode5	Mode6	Mode7	Mode8	Mode9
U16	ADC_CAL0	ADC_CAL0									
T15	ADC_CAL1	ADC_CAL1									
V14	ADC_VREFHI_G0	ADC_VREFHI_G0									
V10	ADC_VREFHI_G1	ADC_VREFHI_G1									
V6	ADC_VREFHI_G2	ADC_VREFHI_G2									
V13	ADC_VREFLO_G0	ADC_VREFLOSRC0									
V11	ADC_VREFLO_G1	ADC_VREFLO1									
V7	ADC_VREFLO_G2	ADC_VREFLOSRC1									
V15	ADC_AIN0	ADC_AIN0									

Table 2-33. Pinmux Mapping Table (continued)

Pin#	Pinlist	Mode0	Mode1	Mode2	Mode3	Mode4	Mode5	Mode6	Mode7	Mode8	Mode9
U15	ADC0_AIN1	ADC0_AIN1									
T14	ADC0_AIN2	ADC0_AIN2									
U14	ADC0_AIN3	ADC0_AIN3									
U13	ADC0_AIN4	ADC0_AIN4									
R14	ADC0_AIN5	ADC0_AIN5									
T11	ADC1_AIN0	ADC1_AIN0									
U11	ADC1_AIN1	ADC1_AIN1									
T12	ADC1_AIN2	ADC1_AIN2									
V12	ADC1_AIN3	ADC1_AIN3									
U12	ADC1_AIN4	ADC1_AIN4									
R12	ADC1_AIN5	ADC1_AIN5									
R10	ADC2_AIN0	ADC2_AIN0									
T10	ADC2_AIN1	ADC2_AIN1									
U10	ADC2_AIN2	ADC2_AIN2									
T9	ADC2_AIN3	ADC2_AIN3									
V9	ADC2_AIN4	ADC2_AIN4									
T8	ADC2_AIN5	ADC2_AIN5									
U7	ADC3_AIN0	ADC3_AIN0									
U8	ADC3_AIN1	ADC3_AIN1									
T7	ADC3_AIN2	ADC3_AIN2									
R7	ADC3_AIN3	ADC3_AIN3									
V8	ADC3_AIN4	ADC3_AIN4									
U9	ADC3_AIN5	ADC3_AIN5									
U6	ADC4_AIN0	ADC4_AIN0									
V5	ADC4_AIN1	ADC4_AIN1									
V4	ADC4_AIN2	ADC4_AIN2									
U5	ADC4_AIN3	ADC4_AIN3									
V3	ADC4_AIN4	ADC4_AIN4									
U4	ADC4_AIN5	ADC4_AIN5									
U3	ATESTV0	ATESTV0									
V2	ATESTV1	ATESTV1									
M2	CLKOUT0	CLKOUT0							GPIO138		
T5	DAC_OUT	DAC_OUT									
T13	DAC_VREF0	DAC_VREF0									
T6	DAC_VREF1	DAC_VREF1									
B2	EPWM0_A	EPWM0_A							GPIO43		
B1	EPWM0_B	EPWM0_B							GPIO44		
D3	EPWM1_A	EPWM1_A							GPIO45		
D2	EPWM1_B	EPWM1_B							GPIO46		
G4	EPWM10_A	EPWM10_A	UART1_CTSn					FSIRX2_DATA0	GPIO63		
J3	EPWM10_B	EPWM10_B	UART2_RTSn					FSIRX2_DATA1	GPIO64		

Table 2-33. Pinmux Mapping Table (continued)

Pin#	Pinlist	Mode0	Mode1	Mode2	Mode3	Mode4	Mode5	Mode6	Mode7	Mode8	Mode9
H1	EPWM11_A	EPWM11_A	UART2_CTSn					GPMC0_CLKLB	GPIO65		
J1	EPWM11_B	EPWM11_B	UART3_RTSn					GPMC0_OEn_Req	GPIO66		
K2	EPWM12_A	EPWM12_A	UART3_CTSn	SPI4_CS1				GPMC0_WEn	GPIO67		
J4	EPWM12_B	EPWM12_B	UART1_DCDn					GPMC0_CSn0	GPIO68		
K4	EPWM13_A	EPWM13_A	UART1_RIn					GPMC0_AD0	GPIO69		
K3	EPWM13_B	EPWM13_B	UART1_DTRn					GPMC0_AD1	GPIO70		
V17	EPWM14_A	EPWM14_A	UART1_DSRn					GPMC0_AD2	GPIO71		
T16	EPWM14_B	EPWM14_B		MII1_RX_ER				GPMC0_AD3	GPIO72		
P15	EPWM15_A	EPWM15_A	UART5_TXD	MII1_COL				GPMC0_AD4	GPIO73		
R16	EPWM15_B	EPWM15_B	UART5_RXD	MII1_CRCS				GPMC0_AD5	GPIO74		
C2	EPWM2_A	EPWM2_A							GPIO47		
C1	EPWM2_B	EPWM2_B							GPIO48		
E2	EPWM3_A	EPWM3_A							GPIO49		
E3	EPWM3_B	EPWM3_B							GPIO50		
D1	EPWM4_A	EPWM4_A							GPIO51		
E4	EPWM4_B	EPWM4_B						FSITX1_CLK	GPIO52		
F2	EPWM5_A	EPWM5_A						FSITX1_DATA0	GPIO53		
G2	EPWM5_B	EPWM5_B						FSITX1_DATA1	GPIO54		
E1	EPWM6_A	EPWM6_A						FSIRX1_CLK	GPIO55		
F3	EPWM6_B	EPWM6_B						FSIRX1_DATA0	GPIO56		
F4	EPWM7_A	EPWM7_A						FSIRX1_DATA1	GPIO57		
F1	EPWM7_B	EPWM7_B							GPIO58		
G3	EPWM8_A	EPWM8_A	UART4_TXD	I2C3_SDA				FSITX2_CLK	GPIO59		
H2	EPWM8_B	EPWM8_B	UART4_RXD	I2C3_SCL				FSITX2_DATA0	GPIO60		
G1	EPWM9_A	EPWM9_A						FSITX2_DATA1	GPIO61		
J2	EPWM9_B	EPWM9_B	UART1_RTSn					FSIRX2_CLK	GPIO62		
B14	EQEP0_A	UART4_RTSn			SPI4_CLK				GPIO130	EQEP0_A	SDFM1_CLK0
A14	EQEP0_B	UART4_CTSn			SPI4_CS0				GPIO131	EQEP0_B	SDFM1_D0
D11	EQEP0_INDEX	UART4_RXD	LIN4_RXD		SPI4_D1				GPIO133	EQEP0_INDEX	SDFM1_D1
C12	EQEP0_STROBE	UART4_TXD	LIN4_TXD		SPI4_D0				GPIO132	EQEP0_STROBE	SDFM1_CLK1
P2	EXT_REFCLK0	EXT_REFCLK0					XBAROUT15		GPIO121		EQEP1_INDEX
A13	I2C0_SCL	I2C0_SCL							GPIO135	EQEP2_B	SDFM1_CLK3
B13	I2C0_SDA	I2C0_SDA							GPIO134	EQEP2_A	SDFM1_CLK2
D7	I2C1_SCL	I2C1_SCL		SPI3_CS0			XBAROUT7		GPIO23		
C8	I2C1_SDA	I2C1_SDA		SPI3_CLK			XBAROUT8		GPIO24		
A9	LIN1_RXD	LIN1_RXD	UART1_RXD	SPI2_CS0			XBAROUT5		GPIO19		
B9	LIN1_TXD	LIN1_TXD	UART1_TXD	SPI2_CLK			XBAROUT6		GPIO20		
B8	LIN2_RXD	LIN2_RXD	UART2_RXD	SPI2_D0					GPIO21		
A8	LIN2_TXD	LIN2_TXD	UART2_TXD	SPI2_D1					GPIO22		
M1	MCAN0_RX	MCAN0_RX	SPI4_CS0						GPIO7		
L1	MCAN0_TX	MCAN0_TX	SPI4_CLK						GPIO8		

Table 2-33. Pinmux Mapping Table (continued)

Pin#	Pinlist	Mode0	Mode1	Mode2	Mode3	Mode4	Mode5	Mode6	Mode7	Mode8	Mode9
L2	MCAN1_RX	MCAN1_RX	SPI4_D0						GPIO9		
K1	MCAN1_TX	MCAN1_TX	SPI4_D1						GPIO10		
A12	MCAN2_RX	MCAN2_RX	UART2_RTSn						GPIO137	EQEP2_INDEX	SDFM1_D3
B12	MCAN2_TX	MCAN2_TX	UART1_RTSn						GPIO136	EQEP2_STROBE	SDFM1_D2
M17	MDIO0_MDC	MDIO0_MDC							GPIO42		
N16	MDIO0_MDIO	MDIO0_MDIO							GPIO41		
A5	MMC0_CD	MMC0_CD	UART0_CTSn	I2C2_SDA			EPWM20_B	GPMC0_AD15	GPIO84	SDFM1_D3	
B6	MMC0_CLK	MMC0_CLK	UART0_RXD	LIN0_RXD			EPWM17_A	GPMC0_AD8	GPIO77	SDFM1_CLK0	
A4	MMC0_CMD	MMC0_CMD	UART0_TXD	LIN0_TXD			EPWM17_B	GPMC0_AD9	GPIO78	SDFM1_D0	
B5	MMC0_D0	MMC0_D0	UART2_RXD	I2C1_SCL			EPWM18_A	GPMC0_AD10	GPIO79	SDFM1_CLK1	
B4	MMC0_D1	MMC0_D1					EPWM18_B	GPMC0_AD11	GPIO80	SDFM1_D1	
A3	MMC0_D2	MMC0_D2	UART2_TXD	I2C1_SDA			EPWM19_A	GPMC0_AD12	GPIO81	SDFM1_CLK2	
A2	MMC0_D3	MMC0_D3	UART3_RTSn				EPWM19_B	GPMC0_AD13	GPIO82	SDFM1_D2	
C6	MMC0_WP	MMC0_WP	UART0_RTSn	I2C2_SCL			EPWM20_A	GPMC0_AD14	GPIO83	SDFM1_CLK3	
R2	PORZ	PORZ									
L18	PR0_MDIO0_MDC	PR0_MDIO0_MDC					EPWM21_B	GPMC0_CSn3	GPIO86		
L17	PR0_MDIO0_MDIO	PR0_MDIO0_MDIO					EPWM21_A	GPMC0_CSn2	GPIO85		
K17	PR0_PRU0_GPO0	PR0_PRU0_GPIO0		RMI12_RXD0	RGMII2_RD0	MII2_RXD0	EPWM25_A	GPMC0_A1	GPIO93		
K18	PR0_PRU0_GPO1	PR0_PRU0_GPIO1		RMI12_RXD1	RGMII2_RD1	MII2_RXD1	EPWM25_B	GPMC0_A2	GPIO94		
G18	PR0_PRU0_GPO10	PR0_PRU0_GPIO10		RMI12_CRS_DV	PR0_UART0_RTSn	MII2_CRS	EPWM23_A	GPMC0_WAIT0	GPIO89		
M16	PR0_PRU0_GPO11	PR0_PRU0_GPIO11		RMI12_TXD0	RGMII2_TD0	MII2_TXD0	EPWM28_A	GPMC0_A7	GPIO99		
M15	PR0_PRU0_GPO12	PR0_PRU0_GPIO12		RMI12_TXD1	RGMII2_TD1	MII2_TXD1	EPWM28_B	GPMC0_A8	GPIO100		
H17	PR0_PRU0_GPO13	PR0_PRU0_GPIO13			RGMII2_TD2	MII2_TXD2	EPWM29_A	GPMC0_A9	GPIO101		
H16	PR0_PRU0_GPO14	PR0_PRU0_GPIO14			RGMII2_TD3	MII2_TXD3	EPWM29_B	GPMC0_A10	GPIO102		
L16	PR0_PRU0_GPO15	PR0_PRU0_GPIO15		RMI12_TX_EN	RGMII2_TX_CTL	MII2_TX_EN	EPWM27_B	GPMC0_A6	GPIO98		
H18	PR0_PRU0_GPO16	PR0_PRU0_GPIO16			RGMII2_TXC	MII2_TXCLK	EPWM27_A	GPMC0_A5	GPIO97		
J18	PR0_PRU0_GPO2	PR0_PRU0_GPIO2			RGMII2_RD2	MII2_RXD2	EPWM26_A	GPMC0_A3	GPIO95		
J17	PR0_PRU0_GPO3	PR0_PRU0_GPIO3			RGMII2_RD3	MII2_RXD3	EPWM26_B	GPMC0_A4	GPIO96		
K16	PR0_PRU0_GPO4	PR0_PRU0_GPIO4			RGMII2_RX_CTL	MII2_RXDV	EPWM24_B	GPMC0_A0	GPIO92		
G17	PR0_PRU0_GPO5	PR0_PRU0_GPIO5		RMI12_RX_ER		MII2_RX_ER	EPWM22_A	GPMC0_DIR	GPIO87		
K15	PR0_PRU0_GPO6	PR0_PRU0_GPIO6		RMI12_REF_CLK	RGMII2_RXC	MII2_RXCLK	EPWM24_A	GPMC0_CSn1	GPIO91		

Table 2-33. Pinmux Mapping Table (continued)

Pin#	Pinlist	Mode0	Mode1	Mode2	Mode3	Mode4	Mode5	Mode6	Mode7	Mode8	Mode9
G15	PR0_PRU0_GPO8	PR0_PRU0_GPIO8					EPWM23_B	GPMC0_WPn	GPIO90		
F17	PR0_PRU0_GPO9	PR0_PRU0_GPIO9			PR0_UART0_CTSn	MII2_COL	EPWM22_B	GPMC0_CLK	GPIO88		
F18	PR0_PRU1_GPO0	PR0_PRU1_GPIO0			FSITX2_DATA1	TRC_DATA6		GPMC0_A13	GPIO109		
G16	PR0_PRU1_GPO1	PR0_PRU1_GPIO1			FSIRX2_CLK	TRC_DATA7		GPMC0_A14	GPIO110		
D17	PR0_PRU1_GPO10	PR0_PRU1_GPIO10			PR0_UART0_TXD	TRC_DATA2	EPWM31_A	GPMC0_BE1n	GPIO105		
B18	PR0_PRU1_GPO11	PR0_PRU1_GPIO11			FSITX3_DATA1	TRC_DATA12		GPMC0_A19	GPIO115		
B17	PR0_PRU1_GPO12	PR0_PRU1_GPIO12			FSIRX3_CLK	TRC_DATA13		GPMC0_A20	GPIO116		
D16	PR0_PRU1_GPO13	PR0_PRU1_GPIO13			FSIRX3_DATA0	TRC_DATA14	XBAROUT11	GPMC0_A21	GPIO117		
C17	PR0_PRU1_GPO14	PR0_PRU1_GPIO14			FSIRX3_DATA1	TRC_DATA15	XBAROUT12	GPMC0_CSn0	GPIO118		
A17	PR0_PRU1_GPO15	PR0_PRU1_GPIO15			FSITX3_DATA0	TRC_DATA11		GPMC0_A18	GPIO114		
C16	PR0_PRU1_GPO16	PR0_PRU1_GPIO16			FSITX3_CLK	TRC_DATA10		GPMC0_A17	GPIO113		
C15	PR0_PRU1_GPO18	PR0_PRU1_GPIO18		UART3_TXD	PR0_IEP0_EDIO_DATA_IN_OUT31	TRC_CTL	XBAROUT14	GPMC0_WAIT1	GPIO120		EQEP1_B
D15	PR0_PRU1_GPO19	PR0_PRU1_GPIO19		UART3_RXD	PR0_IEP0_EDC_SYNC_OUT0	TRC_CLK	XBAROUT13		GPIO119		EQEP1_A
E17	PR0_PRU1_GPO2	PR0_PRU1_GPIO2			FSIRX2_DATA0	TRC_DATA8		GPMC0_A15	GPIO111		
E18	PR0_PRU1_GPO3	PR0_PRU1_GPIO3			FSIRX2_DATA1	TRC_DATA9		GPMC0_A16	GPIO112		
F16	PR0_PRU1_GPO4	PR0_PRU1_GPIO4			FSITX2_DATA0	TRC_DATA5		GPMC0_A12	GPIO108		
F15	PR0_PRU1_GPO5	PR0_PRU1_GPIO5				TRC_DATA0	EPWM30_A	GPMC0_OEn_Req	GPIO103		
E16	PR0_PRU1_GPO6	PR0_PRU1_GPIO6			FSITX2_CLK	TRC_DATA4		GPMC0_A11	GPIO107		
D18	PR0_PRU1_GPO8	PR0_PRU1_GPIO8				TRC_DATA3	EPWM31_B	GPMC0_WEn	GPIO106		
C18	PR0_PRU1_GPO9	PR0_PRU1_GPIO9			PR0_UART0_RXD	TRC_DATA1	EPWM30_B	GPMC0_BE0n_CLE	GPIO104		
N2	QSPI0_CLK	QSPI0_CLK							GPIO2		
P1	QSPI0_CSN0	QSPI0_CSn0							GPIO0		
R3	QSPI0_CSN1	QSPI0_CSn1					XBAROUT0		GPIO1		
N1	QSPI0_D0	QSPI0_D0							GPIO3		
N4	QSPI0_D1	QSPI0_D1							GPIO4		
M4	QSPI0_D2	QSPI0_D2							GPIO5		
P3	QSPI0_D3	QSPI0_D3							GPIO6		
U17	RGMII1_RD0	RGMII1_RD0	RMII1_RXD0	MII1_RXD0				FSITX0_DATA1	GPIO31	EQEP2_STROBE	
T17	RGMII1_RD1	RGMII1_RD1	RMII1_RXD1	MII1_RXD1				FSIRX0_CLK	GPIO32	EQEP2_INDEX	

Table 2-33. Pinmux Mapping Table (continued)

Pin#	Pinlist	Mode0	Mode1	Mode2	Mode3	Mode4	Mode5	Mode6	Mode7	Mode8	Mode9
U18	RGMI1_RD2	RGMI1_RD2		MII1_RXD2				FSIRX0_DATA0	GPIO33	EQEP0_A	
T18	RGMI1_RD3	RGMI1_RD3		MII1_RXD3				FSIRX0_DATA1	GPIO34	EQEP0_B	
R18	RGMI1_RX_CTL	RGMI1_RX_CTL	RMII1_RX_ER	MII1_RXDV				FSITX0_DATA0	GPIO30	EQEP2_B	
R17	RGMI1_RXC	RGMI1_RXC	RMII1_REF_CLK	MII1_RXCLK				FSITX0_CLK	GPIO29	EQEP2_A	
P16	RGMI1_TD0	RGMI1_TD0	RMII1_TXD0	MII1_TXD0				FSITX1_DATA1	GPIO37	EQEP1_A	
P17	RGMI1_TD1	RGMI1_TD1	RMII1_TXD1	MII1_TXD1				FSIRX1_CLK	GPIO38	EQEP1_B	
P18	RGMI1_TD2	RGMI1_TD2	RMII1_CRS_DV	MII1_TXD2				FSIRX1_DATA0	GPIO39	EQEP1_STROBE	
N17	RGMI1_TD3	RGMI1_TD3		MII1_TXD3				FSIRX1_DATA1	GPIO40	EQEP1_INDEX	
M18	RGMI1_TX_CTL	RGMI1_TX_CTL	RMII1_TX_EN	MII1_TX_EN				FSITX1_DATA0	GPIO36	EQEP0_STROBE	
N18	RGMI1_TXC	RGMI1_TXC		MII1_TXCLK				FSITX1_CLK	GPIO35	EQEP0_INDEX	
D4	SAFETY_ERRORN	SAFETY_ERRORN									
B16	SDFM0_CLK0	CLKOUT1							GPIO122	SDFM0_CLK0	EQEP1_STROBE
A16	SDFM0_CLK1	PR0_PRU1_GPIO7	CPTS0_TS_SYNC	UART5_RTSn	PR0_IEP0_EDC_SYNC_OUT1		I2C3_SDA		GPIO124	SDFM0_CLK1	
B15	SDFM0_CLK2	UART5_TXD					I2C3_SCL	GPMC0_ADVn_ALE	GPIO126	SDFM0_CLK2	
A15	SDFM0_CLK3	MCAN3_TX	UART5_RXD						GPIO128	SDFM0_CLK3	
D14	SDFM0_D0	PR0_ECAP0_APWM_OUT							GPIO123	SDFM0_D0	
D13	SDFM0_D1	PR0_PRU1_GPIO17		UART5_CTSn	PR0_IEP0_EDIO_DATA_IN_OUT30				GPIO125	SDFM0_D1	
C13	SDFM0_D2	UART5_RXD							GPIO127	SDFM0_D2	
C14	SDFM0_D3	MCAN3_RX							GPIO129	SDFM0_D3	
A11	SPI0_CLK	SPI0_CLK	UART3_TXD	LIN3_TXD				FSITX0_CLK	GPIO12		
C11	SPI0_CS0	SPI0_CS0	UART3_RXD	LIN3_RXD					GPIO11		
C10	SPI0_D0	SPI0_D0						FSITX0_DATA0	GPIO13		
B11	SPI0_D1	SPI0_D1						FSITX0_DATA1	GPIO14		
A10	SPI1_CLK	SPI1_CLK	UART4_RXD	LIN4_RXD			XBAROUT2	FSIRX0_CLK	GPIO16		
C9	SPI1_CS0	SPI1_CS0	UART4_TXD	LIN4_TXD			XBAROUT1		GPIO15		
B10	SPI1_D0	SPI1_D0	UART5_TXD				XBAROUT3	FSIRX0_DATA0	GPIO17		
D9	SPI1_D1	SPI1_D1	UART5_RXD				XBAROUT4	FSIRX0_DATA1	GPIO18		
B3	TCK	TCK									
C5	TDI	TDI									
C4	TDO	TDO									
U1	TEMPCAL	TEMPCAL									
D5	TMS	TMS									
B7	UART0_CTSN	UART0_CTSn	I2C2_SDA	SPI3_D1	MCAN3_RX	SPI0_CS1	XBAROUT10		GPIO26		
C7	UART0_RTsn	UART0_RTsn	I2C2_SCL	SPI3_D0	MCAN3_TX		XBAROUT9		GPIO25		
A7	UART0_RXD	UART0_RXD	LIN0_RXD						GPIO27		
A6	UART0_TXD	UART0_TXD	LIN0_TXD						GPIO28		
L3	UART1_RXD	UART1_RXD	LIN1_RXD				EPWM16_A	GPMC0_AD6	GPIO75		
M3	UART1_TXD	UART1_TXD	LIN1_TXD				EPWM16_B	GPMC0_AD7	GPIO76		
U2	VSYS_MON	VSYS_MON									

Table 2-33. Pinmux Mapping Table (continued)

Pin#	Pinlist	Mode0	Mode1	Mode2	Mode3	Mode4	Mode5	Mode6	Mode7	Mode8	Mode9
C3	WARMRSTN	WARMRSTn									
T1	XTAL_XI	XTAL_XI									
R1	XTAL_XO	XTAL_XO									

3 Software

3.1 SDK Installation

The TMDSCNCD263-PMIC uses a one-time version of the SDK for the example CCS projects. The download for the one-time SDK can be found here: [MCU-PLUS-SDK-AM263-PMIC](#). This SDK version has been validated and contains the examples from the original TMDSCNCD263 along with new drivers for the Automotive Ethernet interface and PMIC.

4 Hardware Design Files

Note

This User Guide is associated with the TMDSCNCD263-PMIC which is only released as the E1 revision. E2 schematic and layout files were generated to address some of the issues with the E1 design.

Note

If this design is being used as reference, please use the E2 version of the schematic and layout.

To download the zip file containing the design files for the E1 and E2 version of the EVM, click the following [link](#).

5 Additional Information

5.1 Trademarks

Texas Instruments™, Sitara™, and E2E™ are trademarks of Texas Instruments. All trademarks are the property of their respective owners.

5.2 E1 Design Hardware Modifications

The following section describes the hardware modifications that were made to each E1 Control Card.

1. TUSB320 CC Controller GPIO Mode

- The TUSB320 is intended to be used in the GPIO mode to negotiate whether the type-C CC pins represent a power source that is an excellent choice for the Control Card. For the TUSB320 to be GPIO mode, the ADDR pin needs to floating and therefore R170 was removed.
- Modification 1:
 - Depopulate R170



Figure 5-1. Modification 1

2. Bypass PMIC VSYS_3V3C Power

- The PMIC LDO output VSOUT2 is used to power the VSYS_3V3C power net. VSYS_3V3C is used to power loads for various peripheral circuits, many of which are required for AM263x reset and boot.

- The PMIC LDO output VSOUT2 is disabled by default and requires a SPI register write from the AM263x to enable after initial start-up.
- As a workaround, the VSYS_3V3C rail is shorted with the VSYS_3V3A PMIC output.
- Modification 2:
 - Lift pin U30.29 from PMIC to disconnect LDO output of PMIC
 - Short TP359 and TP362 using 22GA wire

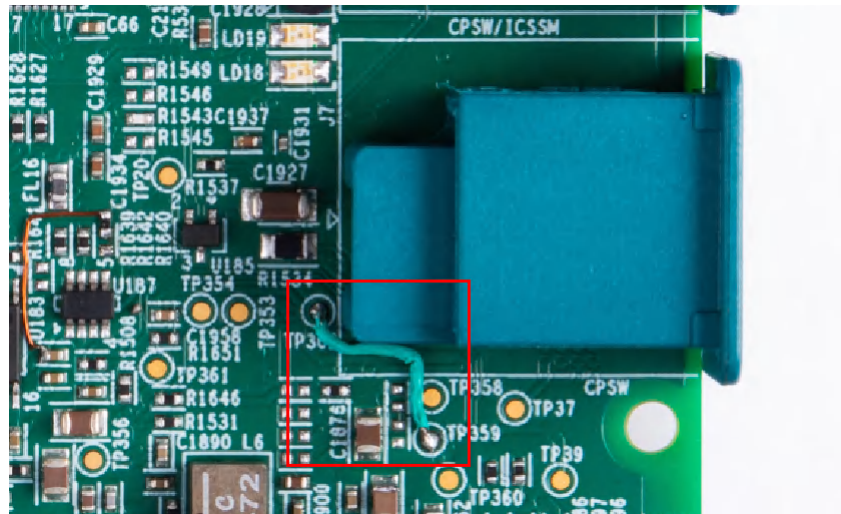

Figure 5-2. Modification 2

3. TPS37042A30 Startup RESET Output Transients

- The TPS37042A30 power supervisor (U187) open-drain outputs RESET1# and RESET2# cause transient PORZ assertions during initial 3.3V (VSYS_3V3A) and 1.2V (VSYS_1V2) power-on.
- These open-drain outputs are pulled to USB-C/HSEC supplied VMAIN 5.0V supply. That VMAIN supply showed noisy behavior during start-up and caused these open-drain I/O to provide a faulty PORZ. Changing U187 RESET1# and RESET2# output pull-up resistors to reference PMIC supplied VDD_5V0 creates a functional PORZ.
- Modification 3:
 - Remove R1640
 - Install 10 kΩ pull-up resistor on the RESET# output pad of the R1640 resistor position
 - Attach the other 10 kΩ resistor pad to the VDD_5V0 power net

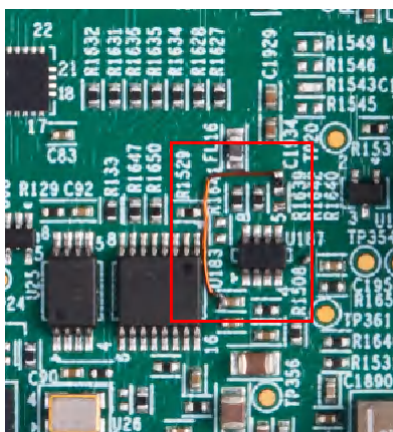

Figure 5-3. Modification 3

6 References

6.1 Reference Documents

In addition to this document, the following references are available for download at www.ti.com.

- [AM2634 Sitara™ Microcontrollers](#)
- [AM263x Sitara™ Microcontrollers Data Sheet](#)
- [AM263x Sitara™ Microcontrollers Technical Reference Manual](#)
- [AM263x Sitara™ Microcontrollers Silicon Errata](#)
- [Texas Instruments Code Composer Studio](#)
- [Updating XDS110 Firmware](#)
 - To find the serial number, only follow steps 1 and 2 of updating XDS110 firmware

6.2 Other TI Components Used in This Design

This Control Card uses various other TI components for the functions. A consolidated list of these components with links to their TI product data sheets is shown below.

- [TPS22918 Load Switch](#)
- [TMP411 Temperature Sensor](#)
- [TCAN1042-Q1 CAN Transceiver](#)
- [XDS110 JTAG Debug Probe](#)
- [DP83869HM 10/100/1000 Ethernet Physical Layer Transceiver](#)
- [DP83826 10/100 Industrial Ethernet PHY](#)
- [TPS3711 Voltage Detector](#)
- [LMK1C110x LVCMOS Clock Buffer](#)
- [INA228 Current Monitor with I2C Interface](#)
- [TLIN2029-Q1 LIN Transceiver](#)
- [TCA6408 8-Bit I2C I/O Expander](#)
- [TPIC2810 8-Bit LED Driver with I2C Interface](#)
- [TCA6416 16-BIT I2C I/O Expander](#)
- [TUSB320LAI USB Type-C Configuration Channel Logic and Port Control](#)
- [TPS212x Power MUX](#)
- [TPS6291x Buck Converter](#)
- [TPS6217x Step-Down Converter](#)
- [TPS22918 Load Switch](#)
- [TPS62097 Step-Down Converter](#)
- [TPS389x Adjustable Voltage Monitor](#)

STANDARD TERMS FOR EVALUATION MODULES

1. *Delivery:* TI delivers TI evaluation boards, kits, or modules, including any accompanying demonstration software, components, and/or documentation which may be provided together or separately (collectively, an "EVM" or "EVMs") to the User ("User") in accordance with the terms set forth herein. User's acceptance of the EVM is expressly subject to the following terms.
 - 1.1 EVMs are intended solely for product or software developers for use in a research and development setting to facilitate feasibility evaluation, experimentation, or scientific analysis of TI semiconductors products. EVMs have no direct function and are not finished products. EVMs shall not be directly or indirectly assembled as a part or subassembly in any finished product. For clarification, any software or software tools provided with the EVM ("Software") shall not be subject to the terms and conditions set forth herein but rather shall be subject to the applicable terms that accompany such Software
 - 1.2 EVMs are not intended for consumer or household use. EVMs may not be sold, sublicensed, leased, rented, loaned, assigned, or otherwise distributed for commercial purposes by Users, in whole or in part, or used in any finished product or production system.
2. *Limited Warranty and Related Remedies/Disclaimers:*
 - 2.1 These terms do not apply to Software. The warranty, if any, for Software is covered in the applicable Software License Agreement.
 - 2.2 TI warrants that the TI EVM will conform to TI's published specifications for ninety (90) days after the date TI delivers such EVM to User. Notwithstanding the foregoing, TI shall not be liable for a nonconforming EVM if (a) the nonconformity was caused by neglect, misuse or mistreatment by an entity other than TI, including improper installation or testing, or for any EVMs that have been altered or modified in any way by an entity other than TI, (b) the nonconformity resulted from User's design, specifications or instructions for such EVMs or improper system design, or (c) User has not paid on time. Testing and other quality control techniques are used to the extent TI deems necessary. TI does not test all parameters of each EVM. User's claims against TI under this Section 2 are void if User fails to notify TI of any apparent defects in the EVMs within ten (10) business days after delivery, or of any hidden defects with ten (10) business days after the defect has been detected.
 - 2.3 TI's sole liability shall be at its option to repair or replace EVMs that fail to conform to the warranty set forth above, or credit User's account for such EVM. TI's liability under this warranty shall be limited to EVMs that are returned during the warranty period to the address designated by TI and that are determined by TI not to conform to such warranty. If TI elects to repair or replace such EVM, TI shall have a reasonable time to repair such EVM or provide replacements. Repaired EVMs shall be warranted for the remainder of the original warranty period. Replaced EVMs shall be warranted for a new full ninety (90) day warranty period.

WARNING

Evaluation Kits are intended solely for use by technically qualified, professional electronics experts who are familiar with the dangers and application risks associated with handling electrical mechanical components, systems, and subsystems.

User shall operate the Evaluation Kit within TI's recommended guidelines and any applicable legal or environmental requirements as well as reasonable and customary safeguards. Failure to set up and/or operate the Evaluation Kit within TI's recommended guidelines may result in personal injury or death or property damage. Proper set up entails following TI's instructions for electrical ratings of interface circuits such as input, output and electrical loads.

NOTE:

EXPOSURE TO ELECTROSTATIC DISCHARGE (ESD) MAY CAUSE DEGRADATION OR FAILURE OF THE EVALUATION KIT; TI RECOMMENDS STORAGE OF THE EVALUATION KIT IN A PROTECTIVE ESD BAG.

3 Regulatory Notices:

3.1 United States

3.1.1 Notice applicable to EVMs not FCC-Approved:

FCC NOTICE: This kit is designed to allow product developers to evaluate electronic components, circuitry, or software associated with the kit to determine whether to incorporate such items in a finished product and software developers to write software applications for use with the end product. This kit is not a finished product and when assembled may not be resold or otherwise marketed unless all required FCC equipment authorizations are first obtained. Operation is subject to the condition that this product not cause harmful interference to licensed radio stations and that this product accept harmful interference. Unless the assembled kit is designed to operate under part 15, part 18 or part 95 of this chapter, the operator of the kit must operate under the authority of an FCC license holder or must secure an experimental authorization under part 5 of this chapter.

3.1.2 For EVMs annotated as FCC – FEDERAL COMMUNICATIONS COMMISSION Part 15 Compliant:

CAUTION

This device complies with part 15 of the FCC Rules. Operation is subject to the following two conditions: (1) This device may not cause harmful interference, and (2) this device must accept any interference received, including interference that may cause undesired operation.

Changes or modifications not expressly approved by the party responsible for compliance could void the user's authority to operate the equipment.

FCC Interference Statement for Class A EVM devices

NOTE: This equipment has been tested and found to comply with the limits for a Class A digital device, pursuant to part 15 of the FCC Rules. These limits are designed to provide reasonable protection against harmful interference when the equipment is operated in a commercial environment. This equipment generates, uses, and can radiate radio frequency energy and, if not installed and used in accordance with the instruction manual, may cause harmful interference to radio communications. Operation of this equipment in a residential area is likely to cause harmful interference in which case the user will be required to correct the interference at his own expense.

FCC Interference Statement for Class B EVM devices

NOTE: This equipment has been tested and found to comply with the limits for a Class B digital device, pursuant to part 15 of the FCC Rules. These limits are designed to provide reasonable protection against harmful interference in a residential installation. This equipment generates, uses and can radiate radio frequency energy and, if not installed and used in accordance with the instructions, may cause harmful interference to radio communications. However, there is no guarantee that interference will not occur in a particular installation. If this equipment does cause harmful interference to radio or television reception, which can be determined by turning the equipment off and on, the user is encouraged to try to correct the interference by one or more of the following measures:

- Reorient or relocate the receiving antenna.
- Increase the separation between the equipment and receiver.
- Connect the equipment into an outlet on a circuit different from that to which the receiver is connected.
- Consult the dealer or an experienced radio/TV technician for help.

3.2 Canada

3.2.1 For EVMs issued with an Industry Canada Certificate of Conformance to RSS-210 or RSS-247

Concerning EVMs Including Radio Transmitters:

This device complies with Industry Canada license-exempt RSSs. Operation is subject to the following two conditions:

(1) this device may not cause interference, and (2) this device must accept any interference, including interference that may cause undesired operation of the device.

Concernant les EVMs avec appareils radio:

Le présent appareil est conforme aux CNR d'Industrie Canada applicables aux appareils radio exempts de licence. L'exploitation est autorisée aux deux conditions suivantes: (1) l'appareil ne doit pas produire de brouillage, et (2) l'utilisateur de l'appareil doit accepter tout brouillage radioélectrique subi, même si le brouillage est susceptible d'en compromettre le fonctionnement.

Concerning EVMs Including Detachable Antennas:

Under Industry Canada regulations, this radio transmitter may only operate using an antenna of a type and maximum (or lesser) gain approved for the transmitter by Industry Canada. To reduce potential radio interference to other users, the antenna type and its gain should be so chosen that the equivalent isotropically radiated power (e.i.r.p.) is not more than that necessary for successful communication. This radio transmitter has been approved by Industry Canada to operate with the antenna types listed in the user guide with the maximum permissible gain and required antenna impedance for each antenna type indicated. Antenna types not included in this list, having a gain greater than the maximum gain indicated for that type, are strictly prohibited for use with this device.

Concernant les EVMs avec antennes détachables

Conformément à la réglementation d'Industrie Canada, le présent émetteur radio peut fonctionner avec une antenne d'un type et d'un gain maximal (ou inférieur) approuvé pour l'émetteur par Industrie Canada. Dans le but de réduire les risques de brouillage radioélectrique à l'intention des autres utilisateurs, il faut choisir le type d'antenne et son gain de sorte que la puissance isotrope rayonnée équivalente (p.i.r.e.) ne dépasse pas l'intensité nécessaire à l'établissement d'une communication satisfaisante. Le présent émetteur radio a été approuvé par Industrie Canada pour fonctionner avec les types d'antenne énumérés dans le manuel d'usage et ayant un gain admissible maximal et l'impédance requise pour chaque type d'antenne. Les types d'antenne non inclus dans cette liste, ou dont le gain est supérieur au gain maximal indiqué, sont strictement interdits pour l'exploitation de l'émetteur.

3.3 Japan

3.3.1 *Notice for EVMs delivered in Japan:* Please see http://www.tij.co.jp/llds/ti_ja/general/eStore/notice_01.page 日本国内に輸入される評価用キット、ボードについては、次のところをご覧ください。

<https://www.ti.com/ja-jp/legal/notice-for-evaluation-kits-delivered-in-japan.html>

3.3.2 *Notice for Users of EVMs Considered "Radio Frequency Products" in Japan:* EVMs entering Japan may not be certified by TI as conforming to Technical Regulations of Radio Law of Japan.

If User uses EVMs in Japan, not certified to Technical Regulations of Radio Law of Japan, User is required to follow the instructions set forth by Radio Law of Japan, which includes, but is not limited to, the instructions below with respect to EVMs (which for the avoidance of doubt are stated strictly for convenience and should be verified by User):

1. Use EVMs in a shielded room or any other test facility as defined in the notification #173 issued by Ministry of Internal Affairs and Communications on March 28, 2006, based on Sub-section 1.1 of Article 6 of the Ministry's Rule for Enforcement of Radio Law of Japan,
2. Use EVMs only after User obtains the license of Test Radio Station as provided in Radio Law of Japan with respect to EVMs, or
3. Use of EVMs only after User obtains the Technical Regulations Conformity Certification as provided in Radio Law of Japan with respect to EVMs. Also, do not transfer EVMs, unless User gives the same notice above to the transferee. Please note that if User does not follow the instructions above, User will be subject to penalties of Radio Law of Japan.

【無線電波を送信する製品の開発キットをお使いになる際の注意事項】 開発キットの中には技術基準適合証明を受けていないものがあります。技術適合証明を受けていないものご使用に際しては、電波法遵守のため、以下のいずれかの措置を取っていただく必要がありますのでご注意ください。

1. 電波法施行規則第6条第1項第1号に基づく平成18年3月28日総務省告示第173号で定められた電波暗室等の試験設備でご使用いただく。
2. 実験局の免許を取得後ご使用いただく。
3. 技術基準適合証明を取得後ご使用いただく。

なお、本製品は、上記の「ご使用にあたっての注意」を譲渡先、移転先に通知しない限り、譲渡、移転できないものとします。

上記を遵守頂けない場合は、電波法の罰則が適用される可能性があることをご留意ください。日本テキサス・イ

ンスツルメンツ株式会社

東京都新宿区西新宿 6 丁目 2 4 番 1 号

西新宿三井ビル

3.3.3 *Notice for EVMs for Power Line Communication:* Please see http://www.tij.co.jp/llds/ti_ja/general/eStore/notice_02.page

電力線搬送波通信についての開発キットをお使いになる際の注意事項については、次のところをご覧ください。 <https://www.ti.com/ja-jp/legal/notice-for-evaluation-kits-for-power-line-communication.html>

3.4 European Union

3.4.1 *For EVMs subject to EU Directive 2014/30/EU (Electromagnetic Compatibility Directive):*

This is a class A product intended for use in environments other than domestic environments that are connected to a low-voltage power-supply network that supplies buildings used for domestic purposes. In a domestic environment this product may cause radio interference in which case the user may be required to take adequate measures.

-
4. *EVM Use Restrictions and Warnings:*
 - 4.1 EVMS ARE NOT FOR USE IN FUNCTIONAL SAFETY AND/OR SAFETY CRITICAL EVALUATIONS, INCLUDING BUT NOT LIMITED TO EVALUATIONS OF LIFE SUPPORT APPLICATIONS.
 - 4.2 User must read and apply the user guide and other available documentation provided by TI regarding the EVM prior to handling or using the EVM, including without limitation any warning or restriction notices. The notices contain important safety information related to, for example, temperatures and voltages.
 - 4.3 *Safety-Related Warnings and Restrictions:*
 - 4.3.1 User shall operate the EVM within TI's recommended specifications and environmental considerations stated in the user guide, other available documentation provided by TI, and any other applicable requirements and employ reasonable and customary safeguards. Exceeding the specified performance ratings and specifications (including but not limited to input and output voltage, current, power, and environmental ranges) for the EVM may cause personal injury or death, or property damage. If there are questions concerning performance ratings and specifications, User should contact a TI field representative prior to connecting interface electronics including input power and intended loads. Any loads applied outside of the specified output range may also result in unintended and/or inaccurate operation and/or possible permanent damage to the EVM and/or interface electronics. Please consult the EVM user guide prior to connecting any load to the EVM output. If there is uncertainty as to the load specification, please contact a TI field representative. During normal operation, even with the inputs and outputs kept within the specified allowable ranges, some circuit components may have elevated case temperatures. These components include but are not limited to linear regulators, switching transistors, pass transistors, current sense resistors, and heat sinks, which can be identified using the information in the associated documentation. When working with the EVM, please be aware that the EVM may become very warm.
 - 4.3.2 EVMs are intended solely for use by technically qualified, professional electronics experts who are familiar with the dangers and application risks associated with handling electrical mechanical components, systems, and subsystems. User assumes all responsibility and liability for proper and safe handling and use of the EVM by User or its employees, affiliates, contractors or designees. User assumes all responsibility and liability to ensure that any interfaces (electronic and/or mechanical) between the EVM and any human body are designed with suitable isolation and means to safely limit accessible leakage currents to minimize the risk of electrical shock hazard. User assumes all responsibility and liability for any improper or unsafe handling or use of the EVM by User or its employees, affiliates, contractors or designees.
 - 4.4 User assumes all responsibility and liability to determine whether the EVM is subject to any applicable international, federal, state, or local laws and regulations related to User's handling and use of the EVM and, if applicable, User assumes all responsibility and liability for compliance in all respects with such laws and regulations. User assumes all responsibility and liability for proper disposal and recycling of the EVM consistent with all applicable international, federal, state, and local requirements.
 5. *Accuracy of Information:* To the extent TI provides information on the availability and function of EVMs, TI attempts to be as accurate as possible. However, TI does not warrant the accuracy of EVM descriptions, EVM availability or other information on its websites as accurate, complete, reliable, current, or error-free.
 6. *Disclaimers:*
 - 6.1 EXCEPT AS SET FORTH ABOVE, EVMS AND ANY MATERIALS PROVIDED WITH THE EVM (INCLUDING, BUT NOT LIMITED TO, REFERENCE DESIGNS AND THE DESIGN OF THE EVM ITSELF) ARE PROVIDED "AS IS" AND "WITH ALL FAULTS." TI DISCLAIMS ALL OTHER WARRANTIES, EXPRESS OR IMPLIED, REGARDING SUCH ITEMS, INCLUDING BUT NOT LIMITED TO ANY EPIDEMIC FAILURE WARRANTY OR IMPLIED WARRANTIES OF MERCHANTABILITY OR FITNESS FOR A PARTICULAR PURPOSE OR NON-INFRINGEMENT OF ANY THIRD PARTY PATENTS, COPYRIGHTS, TRADE SECRETS OR OTHER INTELLECTUAL PROPERTY RIGHTS.
 - 6.2 EXCEPT FOR THE LIMITED RIGHT TO USE THE EVM SET FORTH HEREIN, NOTHING IN THESE TERMS SHALL BE CONSTRUED AS GRANTING OR CONFERRING ANY RIGHTS BY LICENSE, PATENT, OR ANY OTHER INDUSTRIAL OR INTELLECTUAL PROPERTY RIGHT OF TI, ITS SUPPLIERS/LICENSORS OR ANY OTHER THIRD PARTY, TO USE THE EVM IN ANY FINISHED END-USER OR READY-TO-USE FINAL PRODUCT, OR FOR ANY INVENTION, DISCOVERY OR IMPROVEMENT, REGARDLESS OF WHEN MADE, CONCEIVED OR ACQUIRED.
 7. *USER'S INDEMNITY OBLIGATIONS AND REPRESENTATIONS.* USER WILL DEFEND, INDEMNIFY AND HOLD TI, ITS LICENSORS AND THEIR REPRESENTATIVES HARMLESS FROM AND AGAINST ANY AND ALL CLAIMS, DAMAGES, LOSSES, EXPENSES, COSTS AND LIABILITIES (COLLECTIVELY, "CLAIMS") ARISING OUT OF OR IN CONNECTION WITH ANY HANDLING OR USE OF THE EVM THAT IS NOT IN ACCORDANCE WITH THESE TERMS. THIS OBLIGATION SHALL APPLY WHETHER CLAIMS ARISE UNDER STATUTE, REGULATION, OR THE LAW OF TORT, CONTRACT OR ANY OTHER LEGAL THEORY, AND EVEN IF THE EVM FAILS TO PERFORM AS DESCRIBED OR EXPECTED.
-

8. *Limitations on Damages and Liability:*

8.1 *General Limitations.* IN NO EVENT SHALL TI BE LIABLE FOR ANY SPECIAL, COLLATERAL, INDIRECT, PUNITIVE, INCIDENTAL, CONSEQUENTIAL, OR EXEMPLARY DAMAGES IN CONNECTION WITH OR ARISING OUT OF THESE TERMS OR THE USE OF THE EVMS , REGARDLESS OF WHETHER TI HAS BEEN ADVISED OF THE POSSIBILITY OF SUCH DAMAGES. EXCLUDED DAMAGES INCLUDE, BUT ARE NOT LIMITED TO, COST OF REMOVAL OR REINSTALLATION, ANCILLARY COSTS TO THE PROCUREMENT OF SUBSTITUTE GOODS OR SERVICES, RETESTING, OUTSIDE COMPUTER TIME, LABOR COSTS, LOSS OF GOODWILL, LOSS OF PROFITS, LOSS OF SAVINGS, LOSS OF USE, LOSS OF DATA, OR BUSINESS INTERRUPTION. NO CLAIM, SUIT OR ACTION SHALL BE BROUGHT AGAINST TI MORE THAN TWELVE (12) MONTHS AFTER THE EVENT THAT GAVE RISE TO THE CAUSE OF ACTION HAS OCCURRED.

8.2 *Specific Limitations.* IN NO EVENT SHALL TI'S AGGREGATE LIABILITY FROM ANY USE OF AN EVM PROVIDED HEREUNDER, INCLUDING FROM ANY WARRANTY, INDEMNITY OR OTHER OBLIGATION ARISING OUT OF OR IN CONNECTION WITH THESE TERMS, , EXCEED THE TOTAL AMOUNT PAID TO TI BY USER FOR THE PARTICULAR EVM(S) AT ISSUE DURING THE PRIOR TWELVE (12) MONTHS WITH RESPECT TO WHICH LOSSES OR DAMAGES ARE CLAIMED. THE EXISTENCE OF MORE THAN ONE CLAIM SHALL NOT ENLARGE OR EXTEND THIS LIMIT.

9. *Return Policy.* Except as otherwise provided, TI does not offer any refunds, returns, or exchanges. Furthermore, no return of EVM(s) will be accepted if the package has been opened and no return of the EVM(s) will be accepted if they are damaged or otherwise not in a resalable condition. If User feels it has been incorrectly charged for the EVM(s) it ordered or that delivery violates the applicable order, User should contact TI. All refunds will be made in full within thirty (30) working days from the return of the components(s), excluding any postage or packaging costs.

10. *Governing Law:* These terms and conditions shall be governed by and interpreted in accordance with the laws of the State of Texas, without reference to conflict-of-laws principles. User agrees that non-exclusive jurisdiction for any dispute arising out of or relating to these terms and conditions lies within courts located in the State of Texas and consents to venue in Dallas County, Texas. Notwithstanding the foregoing, any judgment may be enforced in any United States or foreign court, and TI may seek injunctive relief in any United States or foreign court.

Mailing Address: Texas Instruments, Post Office Box 655303, Dallas, Texas 75265
Copyright © 2023, Texas Instruments Incorporated

IMPORTANT NOTICE AND DISCLAIMER

TI PROVIDES TECHNICAL AND RELIABILITY DATA (INCLUDING DATA SHEETS), DESIGN RESOURCES (INCLUDING REFERENCE DESIGNS), APPLICATION OR OTHER DESIGN ADVICE, WEB TOOLS, SAFETY INFORMATION, AND OTHER RESOURCES "AS IS" AND WITH ALL FAULTS, AND DISCLAIMS ALL WARRANTIES, EXPRESS AND IMPLIED, INCLUDING WITHOUT LIMITATION ANY IMPLIED WARRANTIES OF MERCHANTABILITY, FITNESS FOR A PARTICULAR PURPOSE OR NON-INFRINGEMENT OF THIRD PARTY INTELLECTUAL PROPERTY RIGHTS.

These resources are intended for skilled developers designing with TI products. You are solely responsible for (1) selecting the appropriate TI products for your application, (2) designing, validating and testing your application, and (3) ensuring your application meets applicable standards, and any other safety, security, regulatory or other requirements.

These resources are subject to change without notice. TI grants you permission to use these resources only for development of an application that uses the TI products described in the resource. Other reproduction and display of these resources is prohibited. No license is granted to any other TI intellectual property right or to any third party intellectual property right. TI disclaims responsibility for, and you will fully indemnify TI and its representatives against, any claims, damages, costs, losses, and liabilities arising out of your use of these resources.

TI's products are provided subject to [TI's Terms of Sale](#) or other applicable terms available either on [ti.com](https://www.ti.com) or provided in conjunction with such TI products. TI's provision of these resources does not expand or otherwise alter TI's applicable warranties or warranty disclaimers for TI products.

TI objects to and rejects any additional or different terms you may have proposed.

Mailing Address: Texas Instruments, Post Office Box 655303, Dallas, Texas 75265
Copyright © 2023, Texas Instruments Incorporated