

| Revision History | | | | |
|------------------|-------|---------------|-------------|-------|
| Rev | ECN # | Approved Date | Approved by | Notes |
| B/E3 | N/A | 01/05/2018 | JAC | N/A |

DEFAULT SWITCH/JUMPER SETTINGS

S3 1..4] ON,ON,ON,OFF (MSP430 IN RESET, TDA2XP I2C MASTER)

S4 [1..4] ON,OFF,OFF,ON(CSI-COAX)

S5[1..4] ON,OFF,OFF,ON(CSI-COAX)

J22 1-2 12V CAMERA

J27 1-2 12V RADAR

J40 POWER INPUT FROM TDA2XP EVM

CHANGE SUMMARY Rev B/E3:

Sheet 2: Mirror Q1 for proper orientation.

Sheet 5: Move led on 1.1V rail to PG for the buck regulator. Consider no-popping the 3.3V and 1.8V leds since PG led is all inclusive.

Change R102 from 220 to 360.

Add Q2 BSS138

Sheet 7: PDB_UB960_cam to 3.3V pullup with RC for reset. R couple in MSP control.

C20 - 10uF

R22 - 487

R26 - 10K

INTB_CAM - Add pullup R186 - 10K

Change camera I2C address population option to 0x3D (R21-13.3k,R25-40.2k)

Sheet 8: PDB_UB960_radar to 3.3V pullup with RC for reset. R couple in MSP control.

C86 - 10uF

R35 - 487

R39 - 10K

INTB_RADAR - Add pullup R245

Change 25Mhz OSC to connect properly to 3.3V supply.

Add L78 - 120 ohm

Add C313 - 0.1uF

Change radar I2C address values for address 0x36 per TI SW team request (R34-113k, R38-88.7k)

Sheet Multiple: NoPop ALL TP except for GND TP41,TP15,TP42,TP40,TP43.

Sheet 10-13

Update serial link components per latest datasheet.

From 0.018uF to 0.015uF - C249, C264, C279, C294, C206, C207, C226, C227

From ADL3225V-470MT-TL000 to LQH3NPZ100MJRL - L51, L62, L70, L74, L28, L29, L38, L39

Layout Changes

1) Fix silkscreen size for eval only.

2) Fix logic text as 518522

3) U1, move the unplugged via out from under the part.

4) Reposition TP5,TP6, TP7 and J11 for easier access.

5) Change the PWB stackup to be symmetrical for top/bottom with reference to GND planes.

Rev A/E2 looks like the diff pair traces were properly sized but the stackup was not adjusted accordingly on both top and bottom. Per simulations this created about a 5-10 ohm delta in impedance.Text

| | | | |
|---------------------------------|----------------------------------------------------------------------------|---------------------|---------------------------------------------------------------------------------------------------------------------------------------------------------------------------------------------|
| Orderable: EVM_orderable | Designed for: Public Release | Mod. Date: 1/5/2018 |  TEXAS INSTRUMENTS http://www.ti.com © Texas Instruments 2017 |
| TID #: N/A | Project Title: ADAS Sensor Fusion Board | | |
| Number: 518520B | Rev: E3 | Sheet Title: | |
| SVN Rev: Not in version control | Assembly Variant: Populated_variant | Sheet: 1 of 15 | |
| Drawn By: | File: ADAS_SF_rev1_CoverSheet.SchDoc | Size: B | |
| Engineer: Spectrum Digital | Contact: http://www.ti.com/support | | |

Texas Instruments and/or its licensors do not warrant the accuracy or completeness of this specification or any information contained therein. Texas Instruments and/or its licensors do not warrant that this design will meet the specifications, will be suitable for your application or fit for any particular purpose, or will operate in an implementation. Texas Instruments and/or its licensors do not warrant that the design is production worthy. You should completely validate and test your design implementation to confirm the system functionality for your application.

Car Battery Input
Vin = 4V - 60V

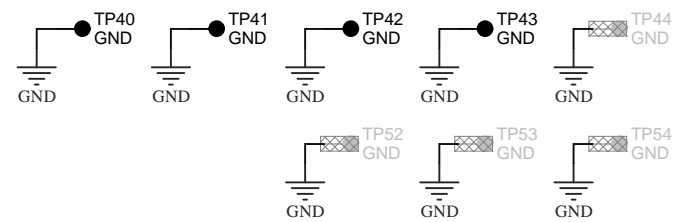
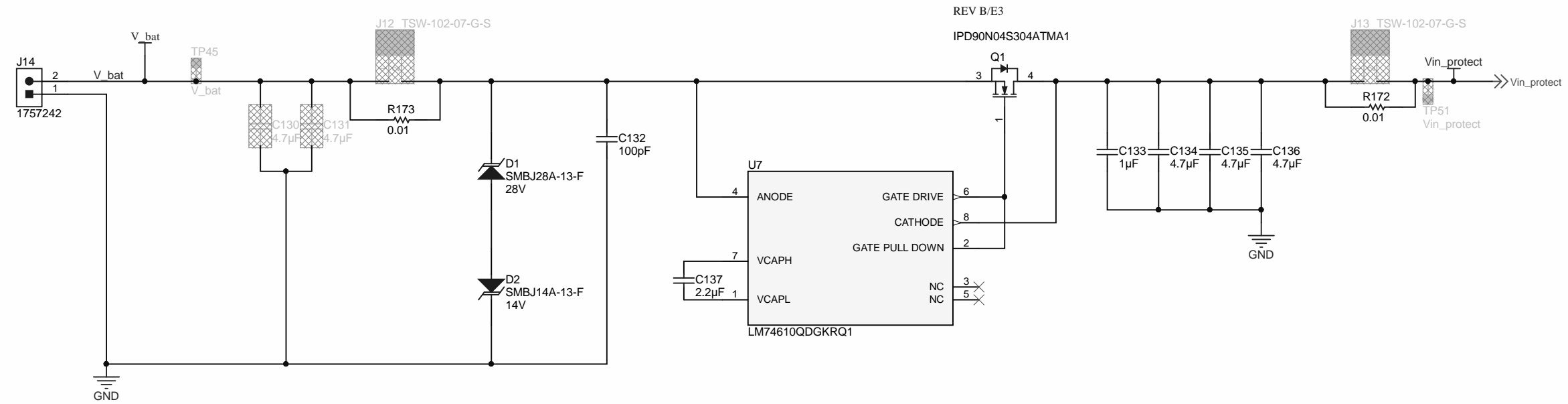

Texas Instruments and/or its licensors do not warrant the accuracy or completeness of this specification or any information contained therein. Texas Instruments and/or its licensors do not warrant that this design will meet the specifications, will be suitable for your application or fit for any particular purpose, or will operate in an implementation. Texas Instruments and/or its licensors do not warrant that the design is production worthy. You should completely validate and test your design implementation to confirm the system functionality for your application.

| | | |
|---------------------------------|----------------------------------------------------------------------------|----------------------|
| Orderable: EVM_orderable | Designed for: Public Release | Mod. Date: 6/15/2017 |
| TID #: N/A | Project Title: ADAS Sensor Fusion Board | |
| Number: 518520B | Rev: E3 | Sheet Title: |
| SVN Rev: Not in version control | Assembly Variant: Populated_variant | Sheet: 2 of 15 |
| Drawn By: | File: ADAS_SF_Power_Battery_Input.SchDoc | Size: B |
| Engineer: Spectrum Digital | Contact: http://www.ti.com/support | |

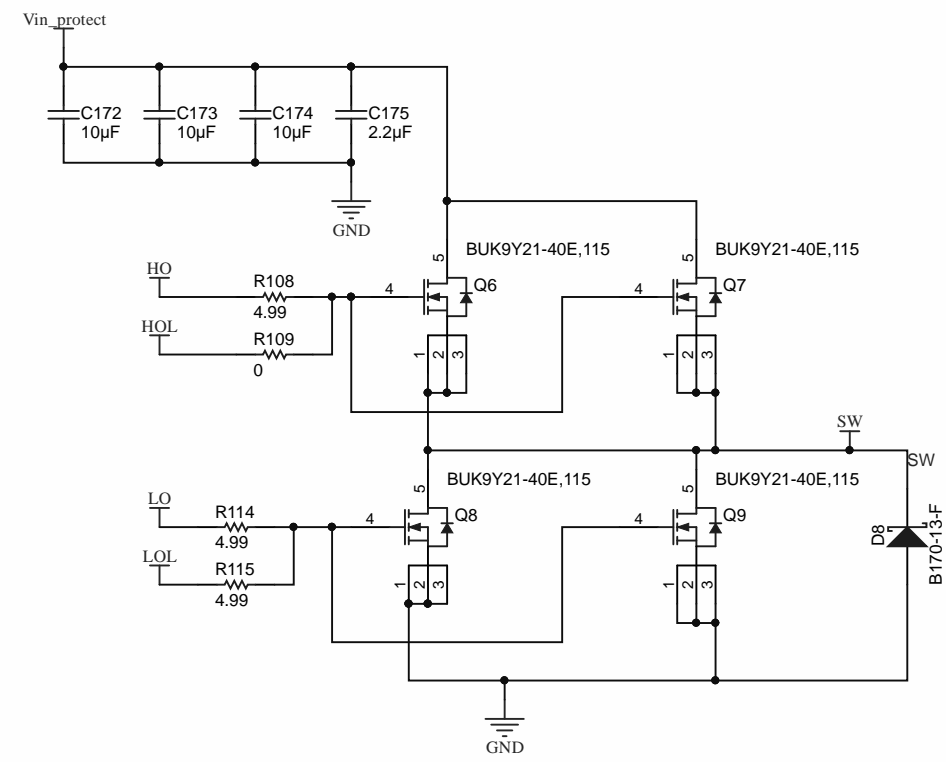
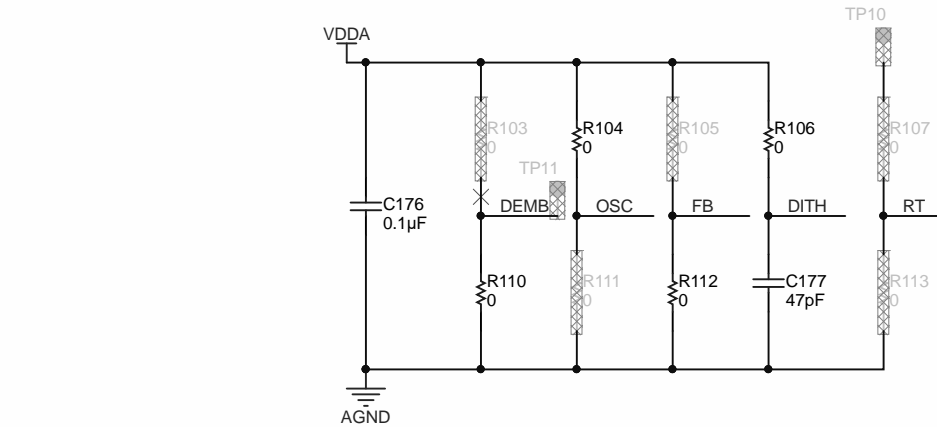

5Vout @ 10A Max.

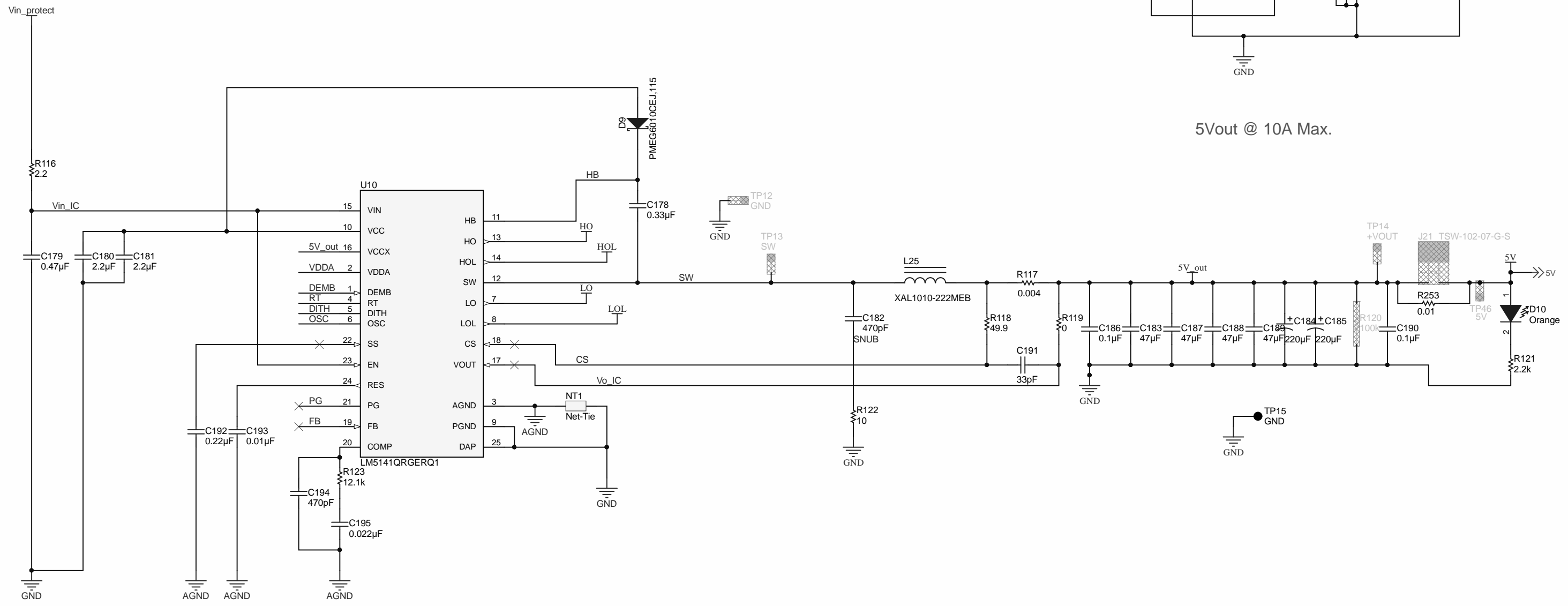

Texas Instruments and/or its licensors do not warrant the accuracy or completeness of this specification or any information contained therein. Texas Instruments and/or its licensors do not warrant that this design will meet the specifications, will be suitable for your application or fit for any particular purpose, or will operate in an implementation. Texas Instruments and/or its licensors do not warrant that the design is production worthy. You should completely validate and test your design implementation to confirm the system functionality for your application.

| | | |
|---------------------------------|-----------------------------------------|----------------------|
| Orderable: EVM_orderable | Designed for: Public Release | Mod. Date: 8/25/2017 |
| TID #: N/A | Project Title: ADAS Sensor Fusion Board | |
| Number: 518520B | Rev: E3 | Sheet Title: |
| SVN Rev: Not in version control | Assembly Variant: Populated_variant | Sheet: 3 of 15 |
| Drawn By: | File: ADAS_SF_Power_Buck_5V.SchDoc | Size: B |
| Engineer: Spectrum Digital | Contact: http://www.ti.com/support | |



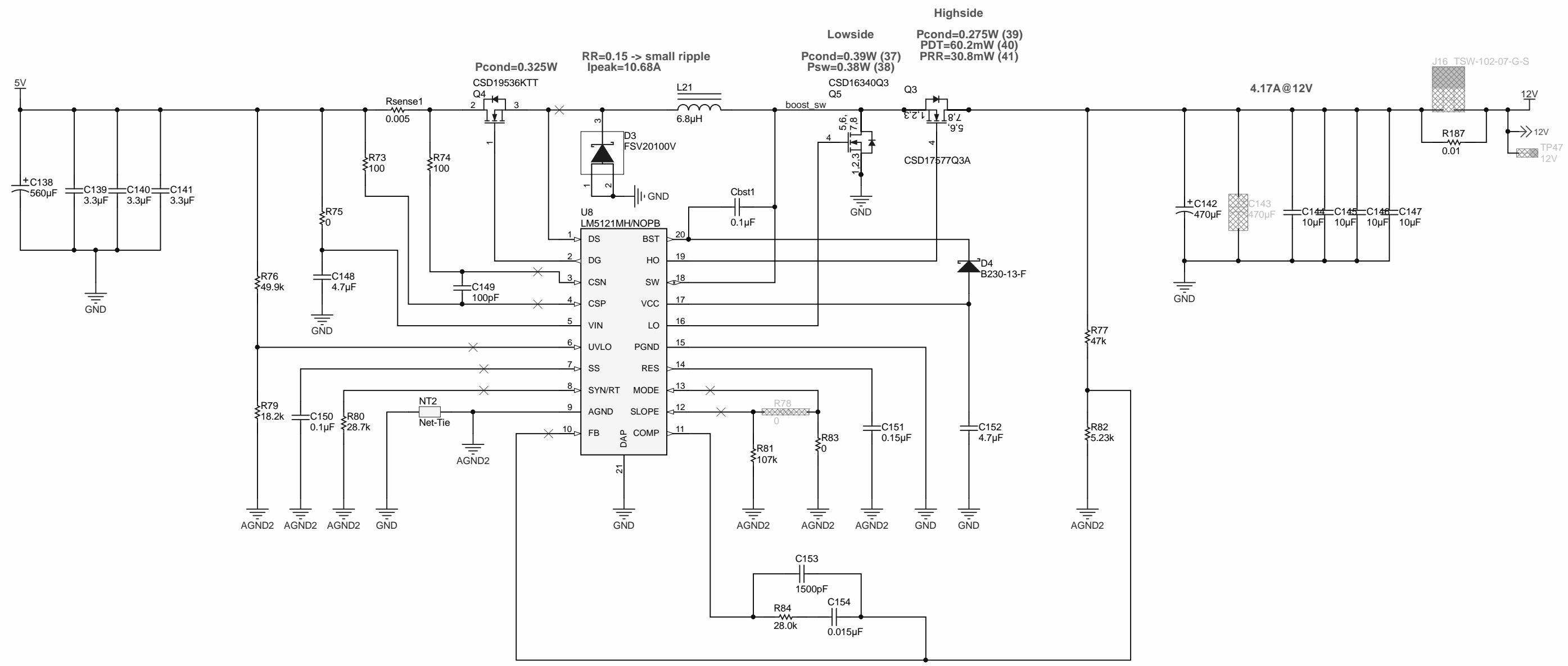

Texas Instruments and/or its licensors do not warrant the accuracy or completeness of this specification or any information contained therein. Texas Instruments and/or its licensors do not warrant that this design will meet the specifications, will be suitable for your application or fit for any particular purpose, or will operate in an implementation. Texas Instruments and/or its licensors do not warrant that the design is production worthy. You should completely validate and test your design implementation to confirm the system functionality for your application.

| | | |
|---------------------------------|-----------------------------------------|----------------------|
| Orderable: EVM_orderable | Designed for: Public Release | Mod. Date: 8/25/2017 |
| TID #: N/A | Project Title: ADAS Sensor Fusion Board | |
| Number: 518520B | Rev: E3 | Sheet Title: |
| SVN Rev: Not in version control | Assembly Variant: Populated_variant | Sheet: 4 of 15 |
| Drawn By: | File: ADAS_SF_Power_Boost_12V.SchDoc | Size: B |
| Engineer: Spectrum Digital | Contact: http://www.ti.com/support | |



© Texas Instruments 2017

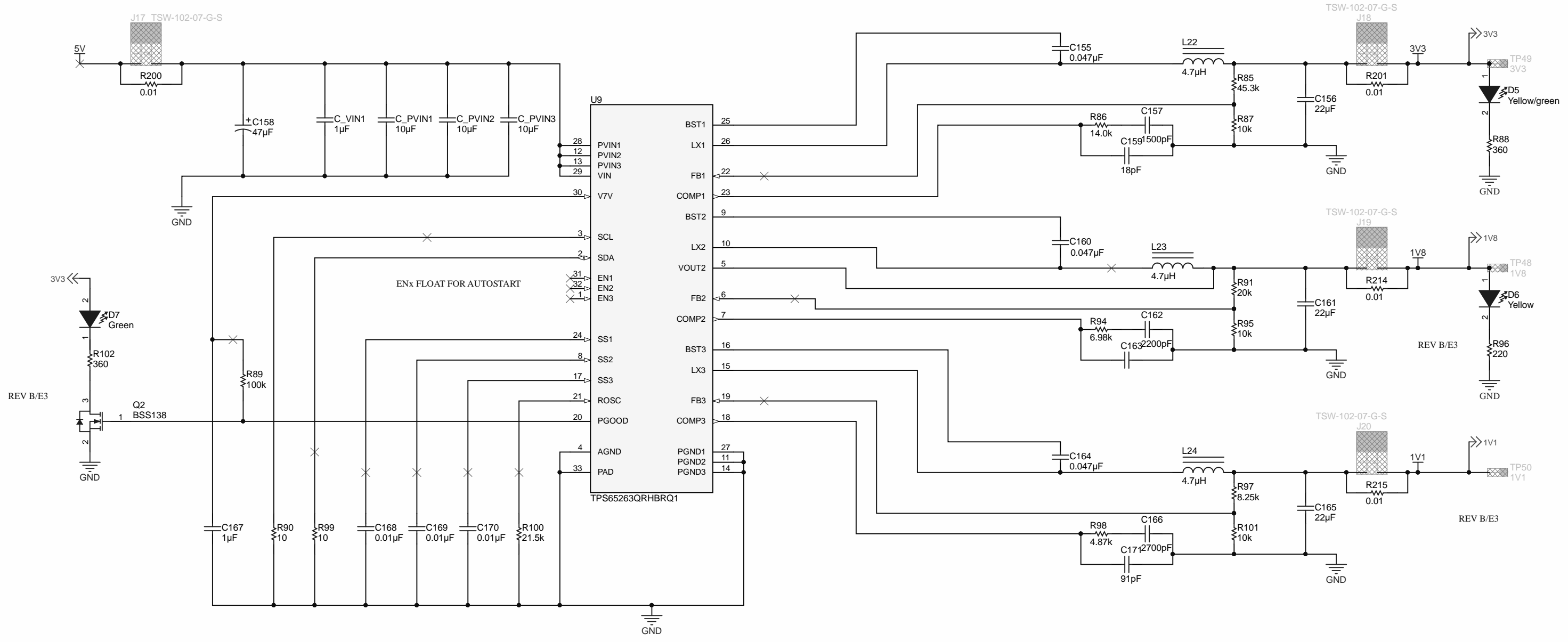

REV B/E3

REV B/E3

REV B/E3

| | | |
|---------------------------------|---------------------------------------------|----------------------|
| Orderable: EVM_orderable | Designed for: Public Release | Mod. Date: 9/25/2017 |
| TID #: N/A | Project Title: ADAS Sensor Fusion Board | |
| Number: 518520B | Rev: E3 | Sheet Title: |
| SVN Rev: Not in version control | Assembly Variant: Populated_variant | Sheet: 5 of 15 |
| Drawn By: | File: ADAS_SF_Power_Buck_3V3_1V8_1V1.SchDoc | Size: B |
| Engineer: Spectrum Digital | Contact: http://www.ti.com/support | |

Texas Instruments and/or its licensors do not warrant the accuracy or completeness of this specification or any information contained therein. Texas Instruments and/or its licensors do not warrant that this design will meet the specifications, will be suitable for your application or fit for any particular purpose, or will operate in an implementation. Texas Instruments and/or its licensors do not warrant that the design is production worthy. You should completely validate and test your design implementation to confirm the system functionality for your application.



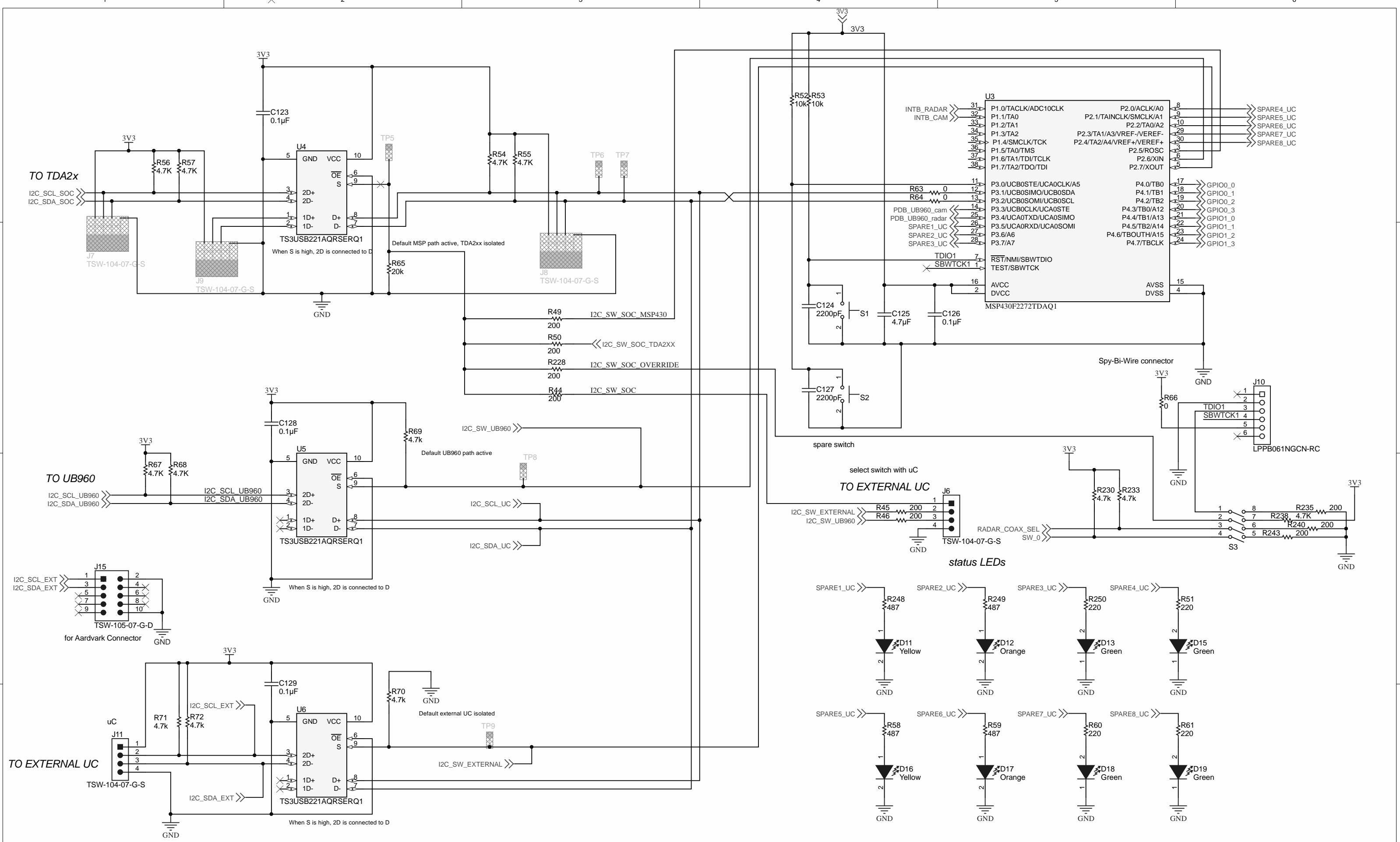

Texas Instruments and/or its licensors do not warrant the accuracy or completeness of this specification or any information contained therein. Texas Instruments and/or its licensors do not warrant that this design will meet the specifications, will be suitable for your application or fit for any particular purpose, or will operate in an implementation. Texas Instruments and/or its licensors do not warrant that the design is production worthy. You should completely validate and test your design implementation to confirm the system functionality for your application.

| | | |
|---------------------------------|-----------------------------------------|----------------------|
| Orderable: EVM_orderable | Designed for: Public Release | Mod. Date: 6/15/2017 |
| TID #: N/A | Project Title: ADAS Sensor Fusion Board | |
| Number: 518520B | Rev: E3 | Sheet Title: |
| SVN Rev: Not in version control | Assembly Variant: Populated_variant | Sheet: 6 of 15 |
| Drawn By: | File: ADAS_SF_Data_MSP430.SchDoc | Size: B |
| Engineer: Spectrum Digital | Contact: http://www.ti.com/support | |



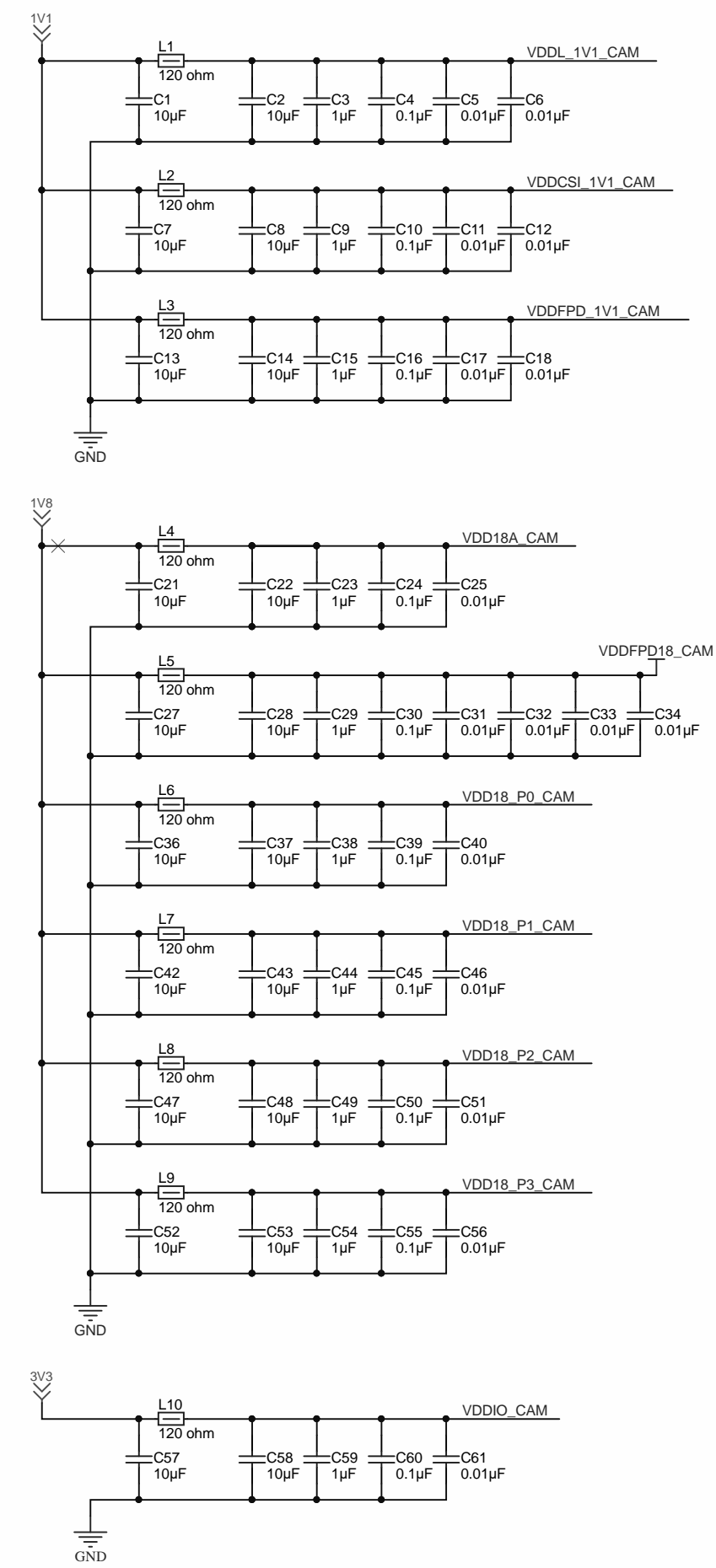
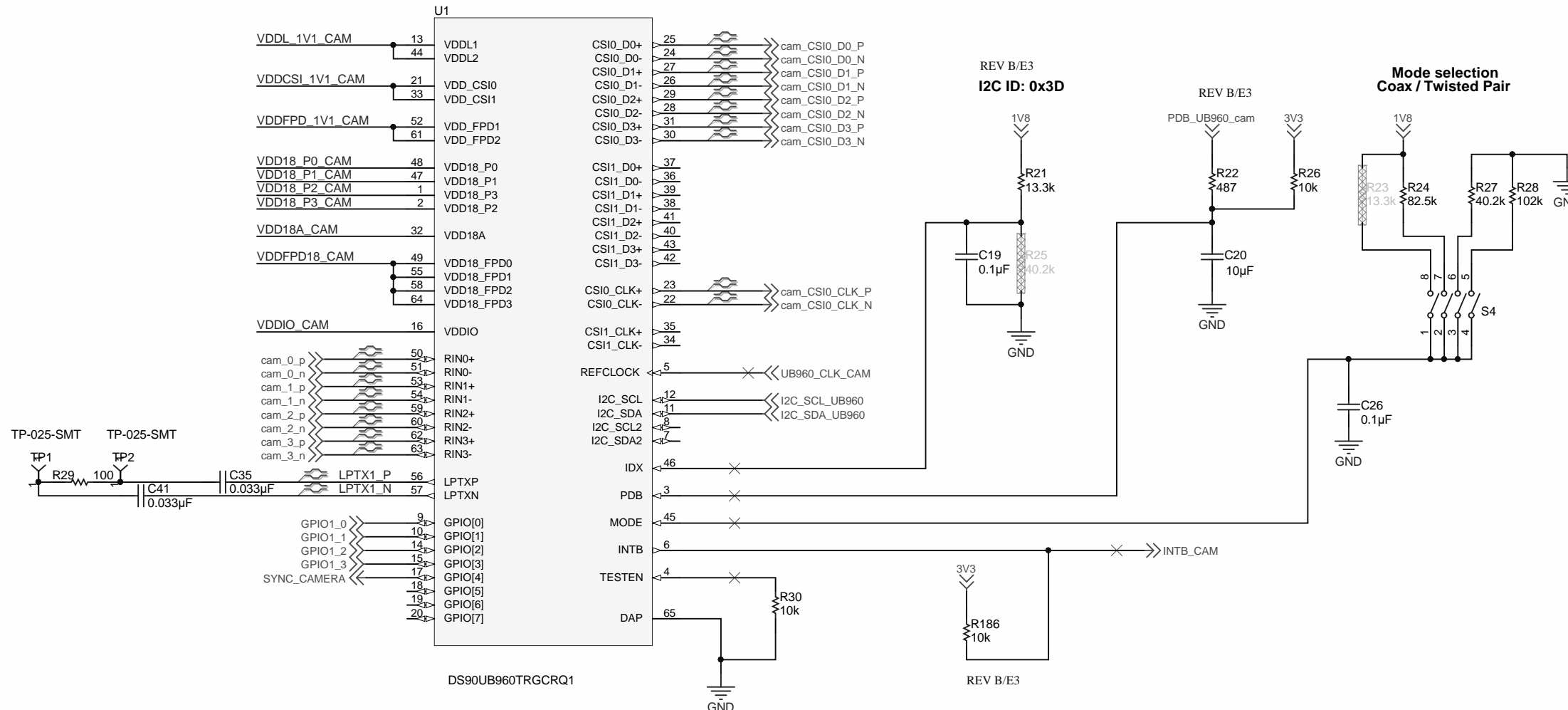

Texas Instruments and/or its licensors do not warrant the accuracy or completeness of this specification or any information contained therein. Texas Instruments and/or its licensors do not warrant that this design will meet the specifications, will be suitable for your application or fit for any particular purpose, or will operate in an implementation. Texas Instruments and/or its licensors do not warrant that the design is production worthy. You should completely validate and test your design implementation to confirm the system functionality for your application.

| | | |
|---------------------------------|-----------------------------------------------|-----------------------|
| Orderable: EVM_orderable | Designed for: Public Release | Mod. Date: 10/18/2017 |
| TID #: N/A | Project Title: ADAS Sensor Fusion Board | |
| Number: 518520B | Rev: E3 | Sheet Title: |
| SVN Rev: Not in version control | Assembly Variant: Populated_variant | Sheet: 7 of 15 |
| Drawn By: | File: ADAS_SF_Data_Deserializer_Camera.SchDoc | Size: B |
| Engineer: Spectrum Digital | Contact: http://www.ti.com/support | |



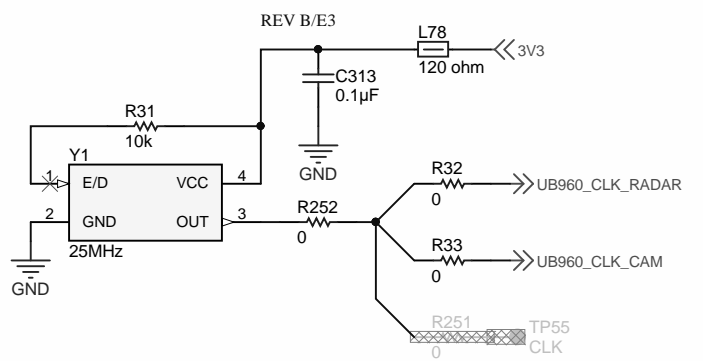

Place 10µF, 1µF, 0.1µF and 0.01µF bypass caps on bottom of board, close to U1 VDD pins

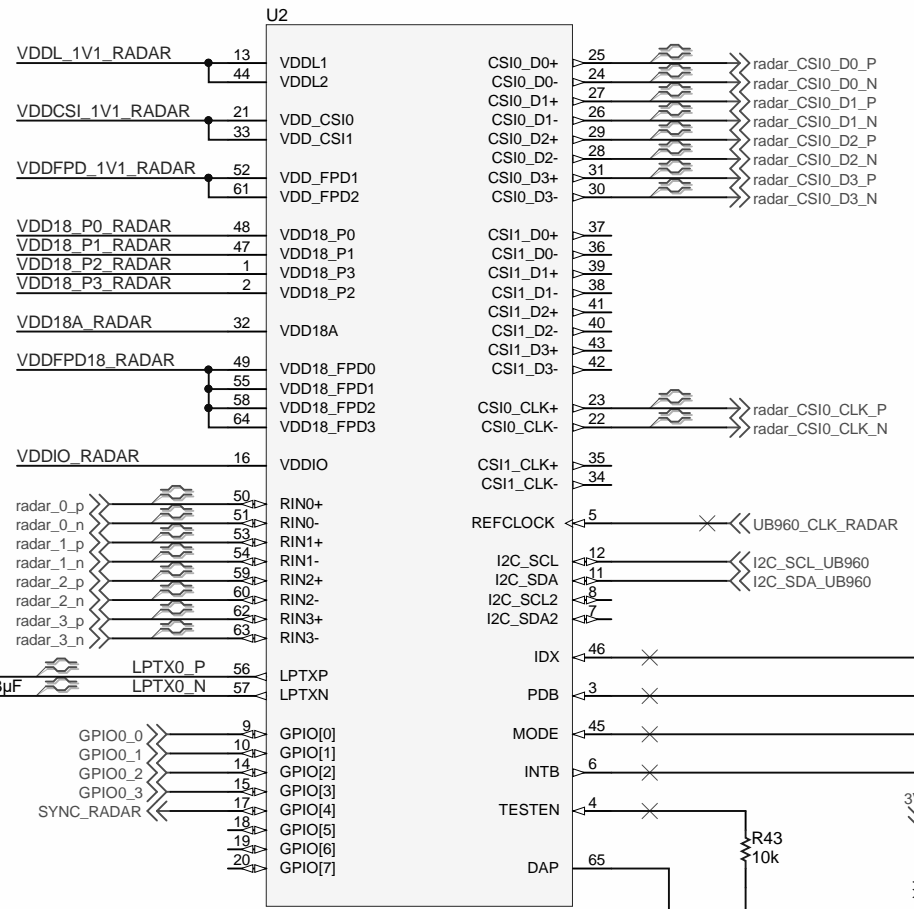

DS90UB960TRGCRQ1

REV B/E3
I2C ID: 0x36

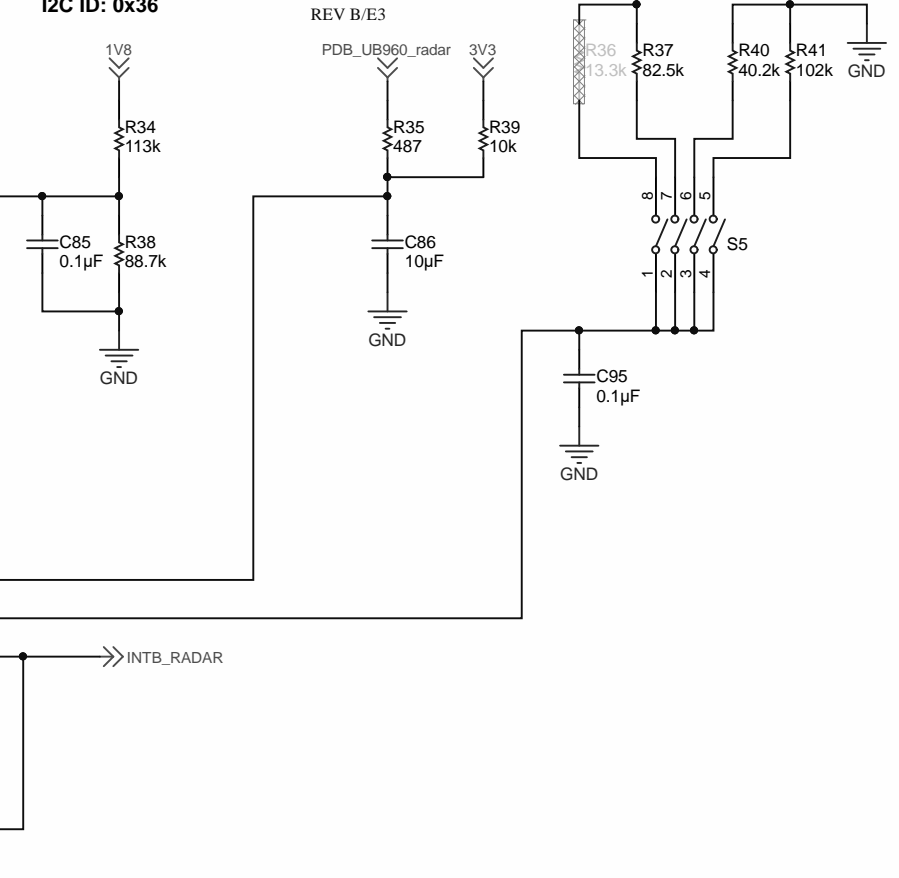

Mode selection
Coax / Twisted Pair

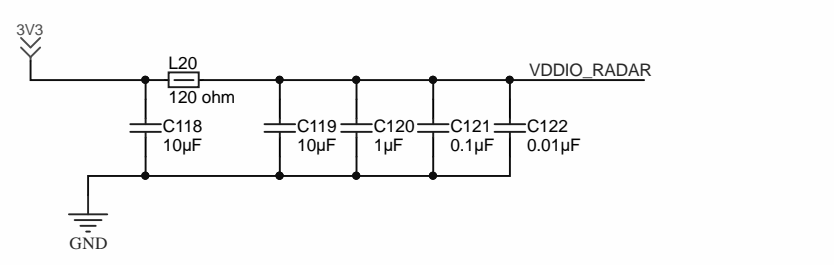
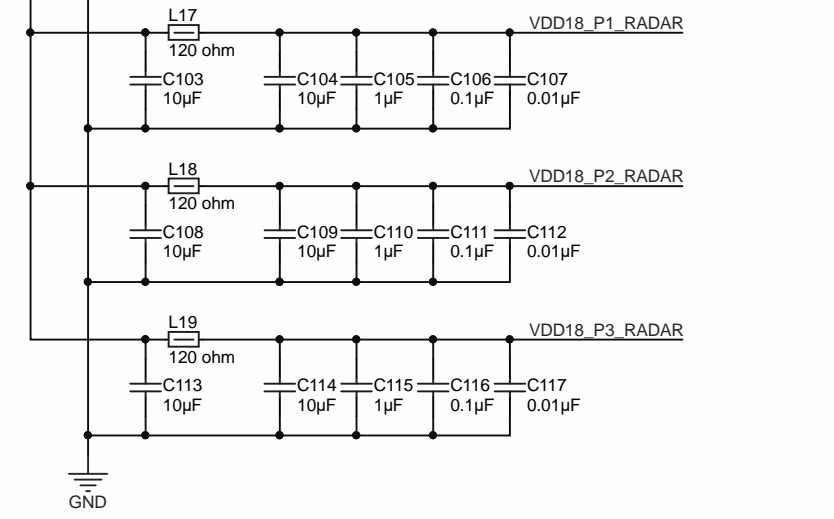
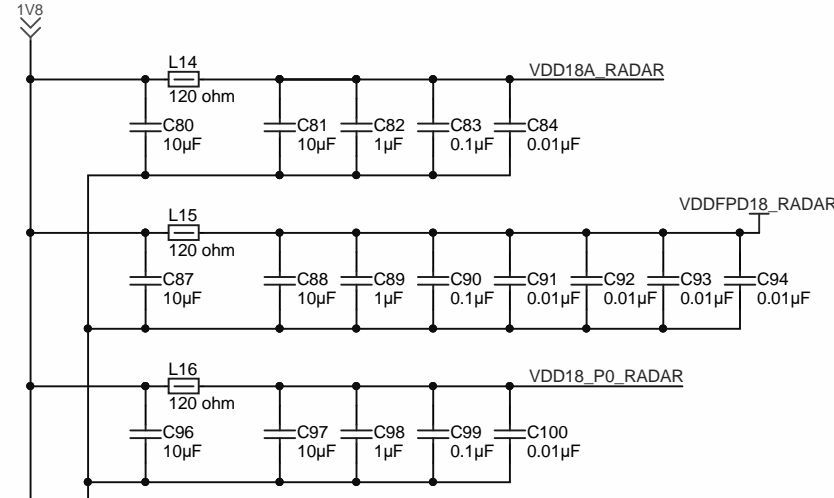
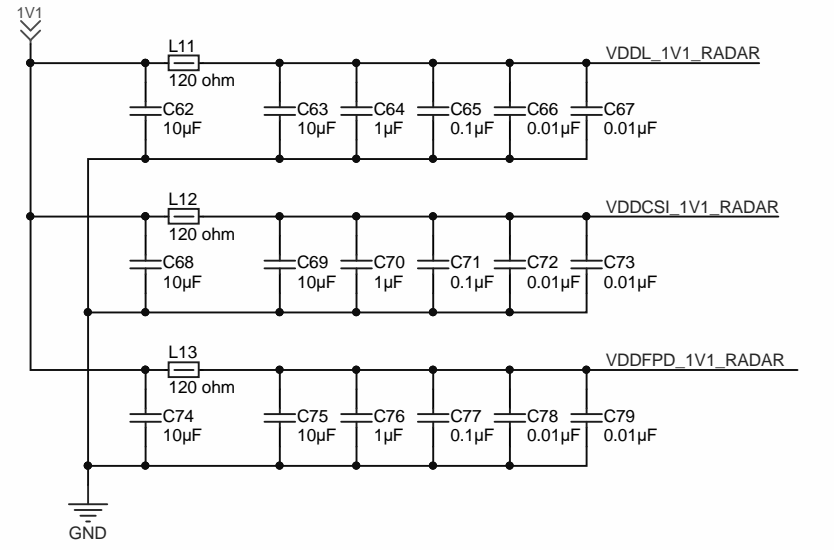

Texas Instruments and/or its licensors do not warrant the accuracy or completeness of this specification or any information contained therein. Texas Instruments and/or its licensors do not warrant that this design will meet the specifications, will be suitable for your application or fit for any particular purpose, or will operate in an implementation. Texas Instruments and/or its licensors do not warrant that the design is production worthy. You should completely validate and test your design implementation to confirm the system functionality for your application.

| | | |
|---------------------------------|----------------------------------------------|----------------------|
| Orderable: EVM_orderable | Designed for: Public Release | Mod. Date: 9/26/2017 |
| TID #: N/A | Project Title: ADAS Sensor Fusion Board | |
| Number: 518520B | Rev: E3 | Sheet Title: |
| SVN Rev: Not in version control | Assembly Variant: Populated_variant | Sheet: 8 of 15 |
| Drawn By: | File: ADAS_SF_Data_Deserializer_Radar.SchDoc | Size: B |
| Engineer: Spectrum Digital | Contact: http://www.ti.com/support | |



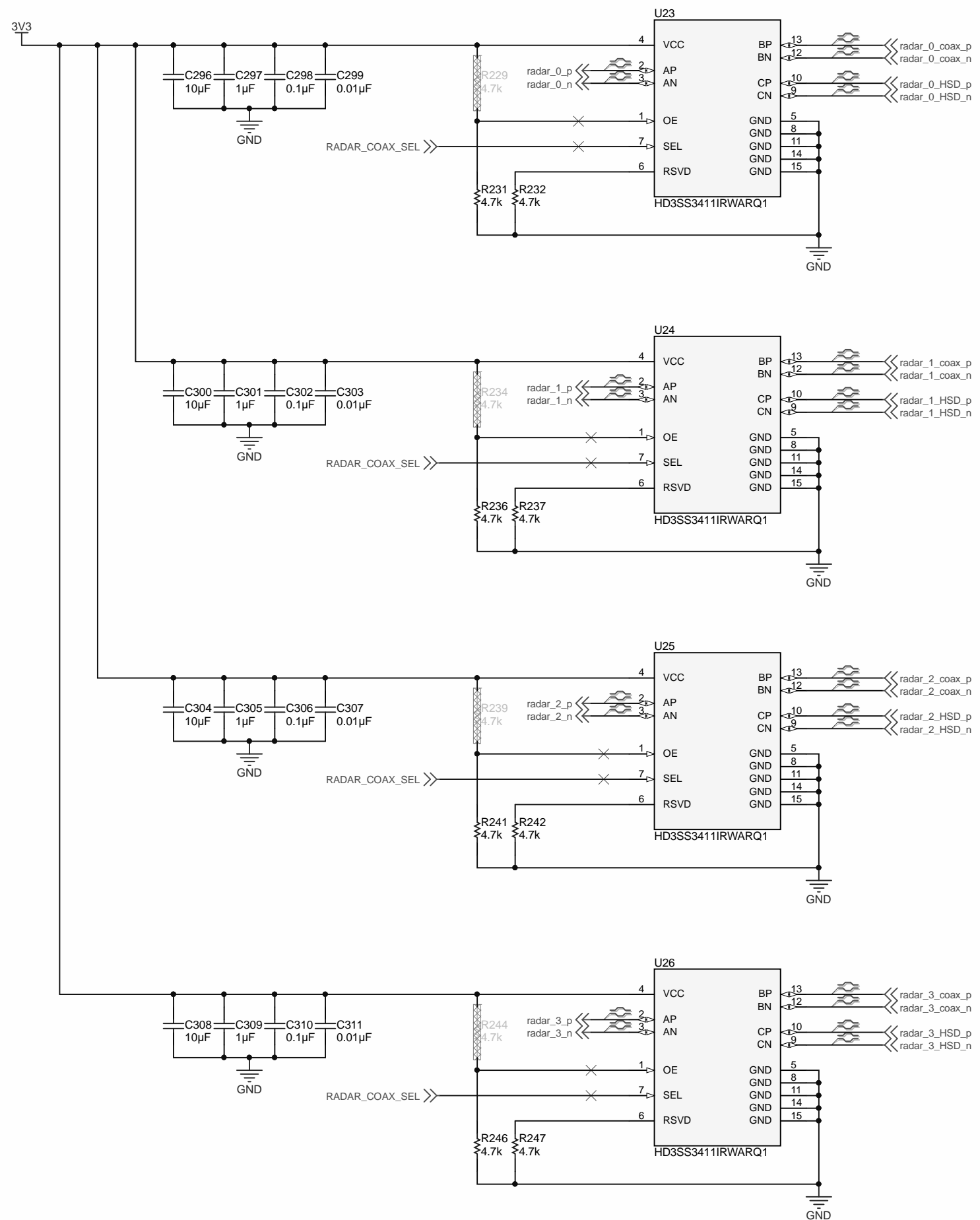

Texas Instruments and/or its licensors do not warrant the accuracy or completeness of this specification or any information contained therein. Texas Instruments and/or its licensors do not warrant that this design will meet the specifications, will be suitable for your application or fit for any particular purpose, or will operate in an implementation. Texas Instruments and/or its licensors do not warrant that the design is production worthy. You should completely validate and test your design implementation to confirm the system functionality for your application.

| | | |
|---------------------------------|----------------------------------------------------------------------------|----------------------|
| Orderable: EVM_orderable | Designed for: Public Release | Mod. Date: 6/15/2017 |
| TID #: N/A | Project Title: ADAS Sensor Fusion Board | |
| Number: 518520B | Rev: E3 | Sheet Title: |
| SVN Rev: Not in version control | Assembly Variant: Populated_variant | Sheet: 9 of 15 |
| Drawn By: | File: ADAS_SF_Data_Radar_Mux.SchDoc | Size: B |
| Engineer: Spectrum Digital | Contact: http://www.ti.com/support | |



© Texas Instruments 2017

$R_{lim} = 89/R_{lim}(kohm)$
 88.7k for ~1Amp
 139k for .64Amp
 1500pf for inrush

Power Selection

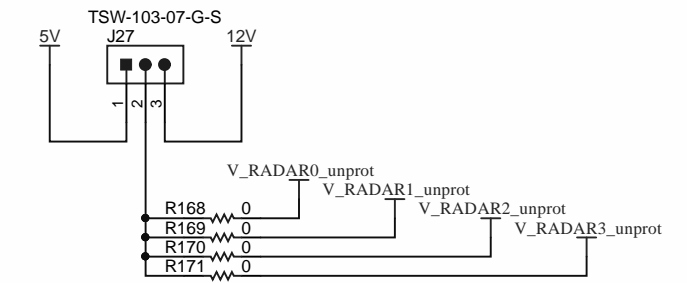

Radar 0 - mount option 1: HSD

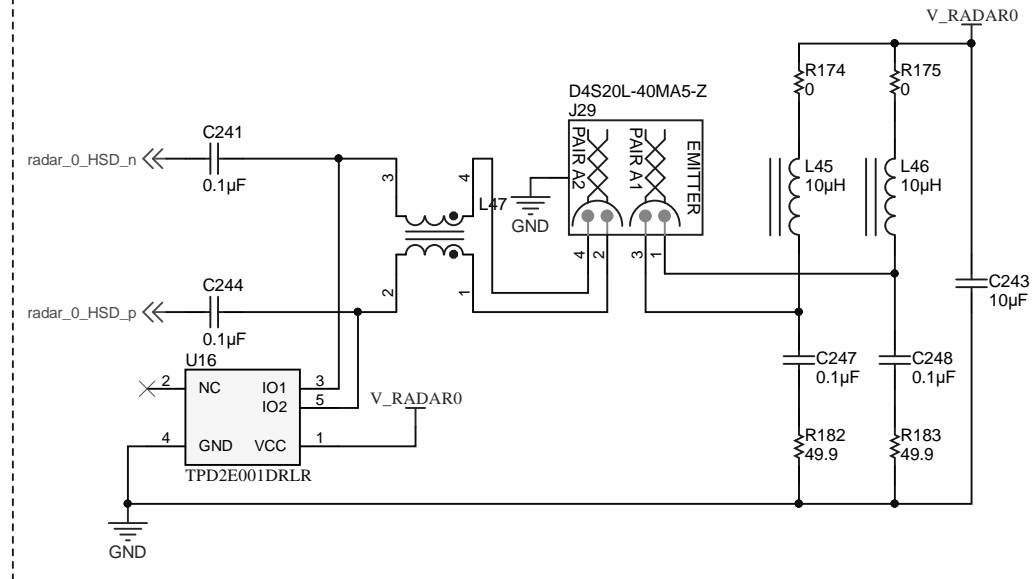

Radar 0 - mount option 2: Coax

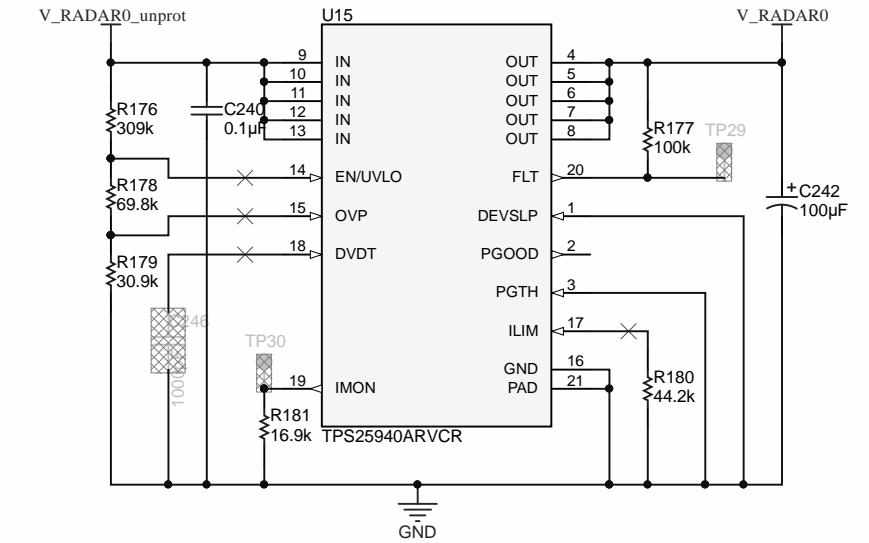
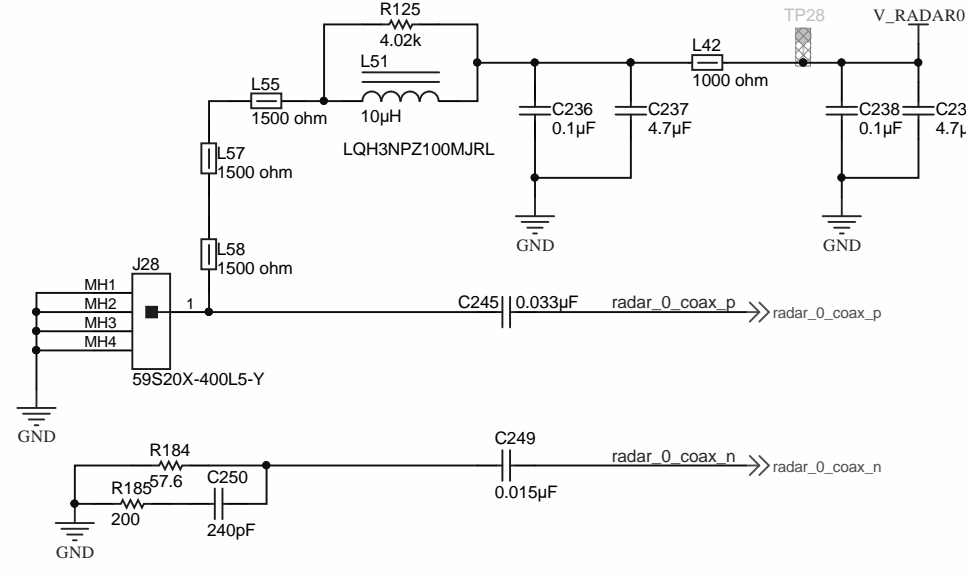

Radar 1 - mount option 1: HSD

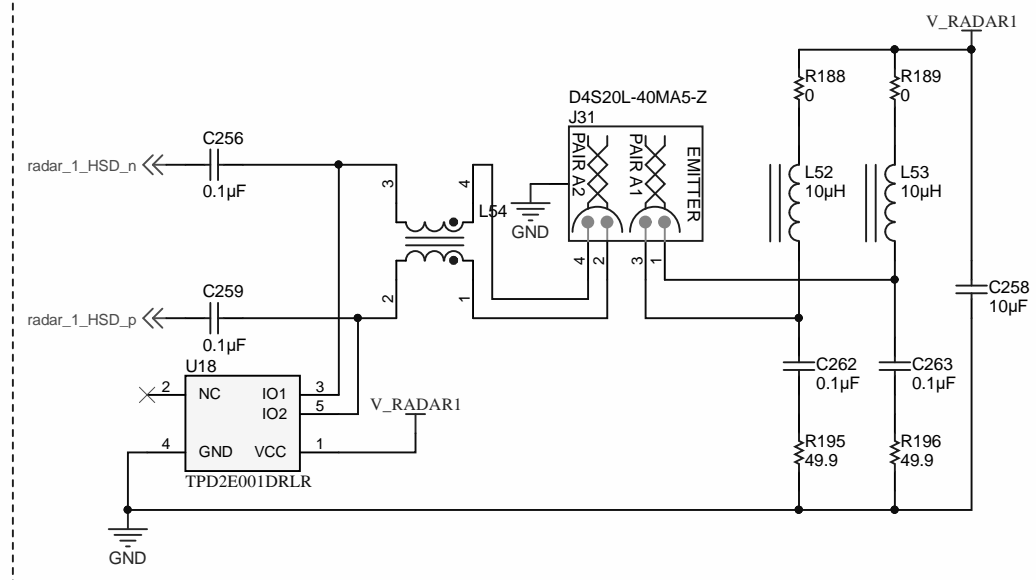

Radar 1 - mount option 2: Coax

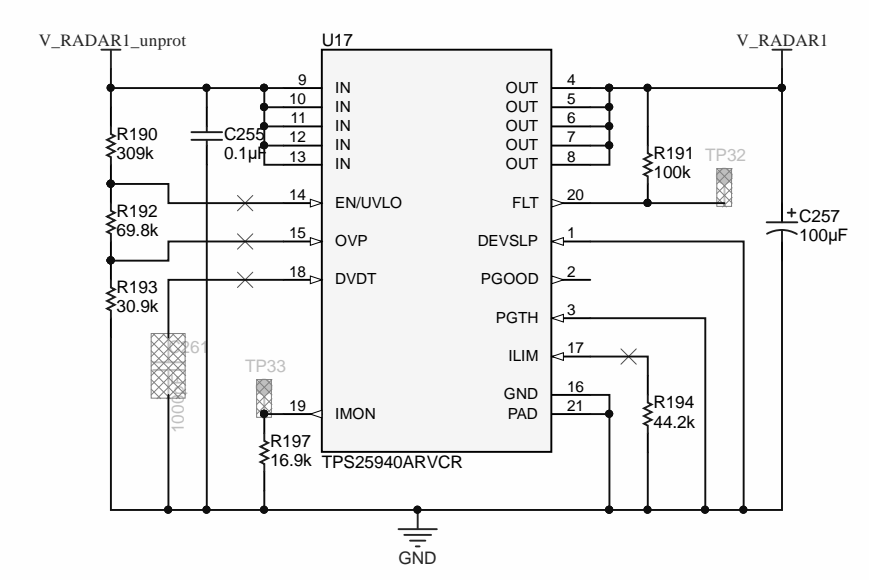
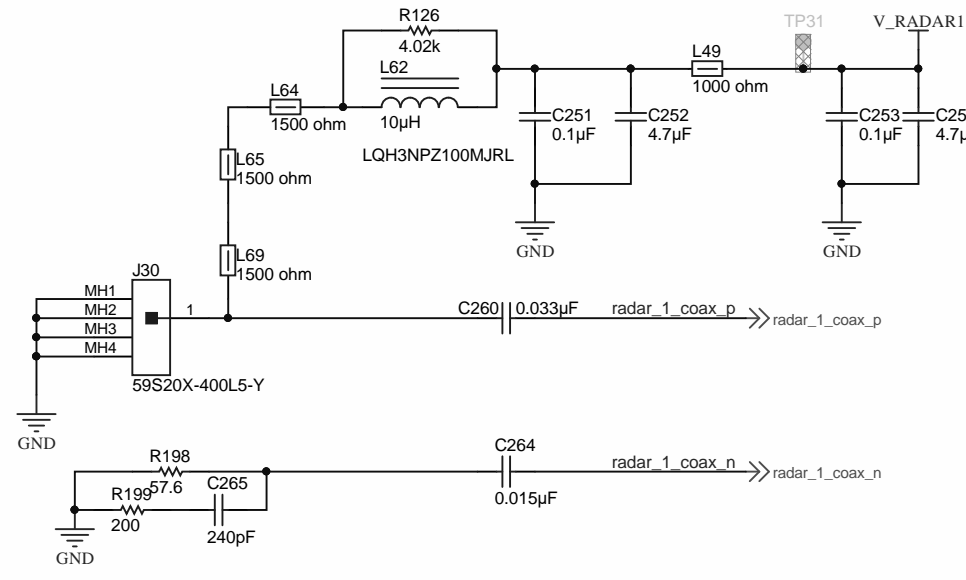

Texas Instruments and/or its licensors do not warrant the accuracy or completeness of this specification or any information contained therein. Texas Instruments and/or its licensors do not warrant that this design will meet the specifications, will be suitable for your application or fit for any particular purpose, or will operate in an implementation. Texas Instruments and/or its licensors do not warrant that the design is production worthy. You should completely validate and test your design implementation to confirm the system functionality for your application.

| | | |
|---------------------------------|-----------------------------------------------|---------------------|
| Orderable: EVM_orderable | Designed for: Public Release | Mod. Date: 1/5/2018 |
| TID #: N/A | Project Title: ADAS Sensor Fusion Board | |
| Number: 518520B | Rev: E3 | Sheet Title: |
| SVN Rev: Not in version control | Assembly Variant: Populated_variant | Sheet: 10 of 15 |
| Drawn By: | File: ADAS_SF_Data_Connection_Radar_01.SchDoc | Size: B |
| Engineer: Spectrum Digital | Contact: http://www.ti.com/support | |



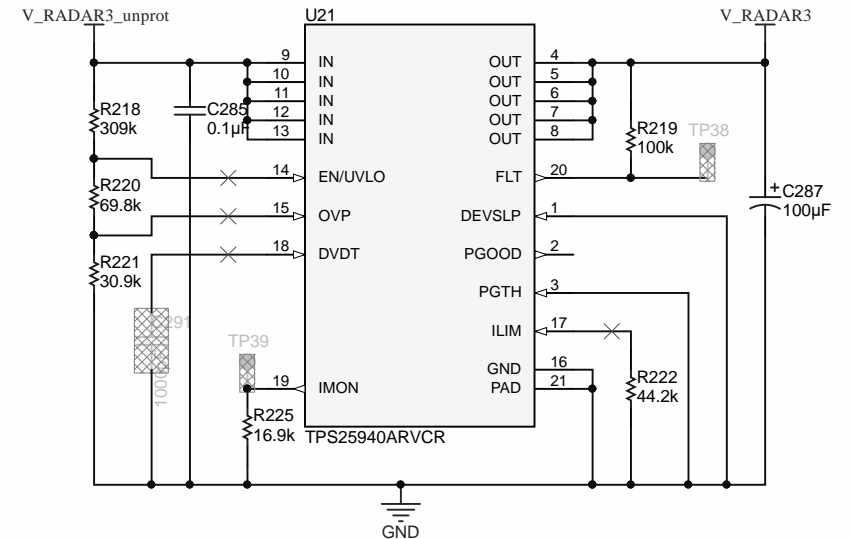
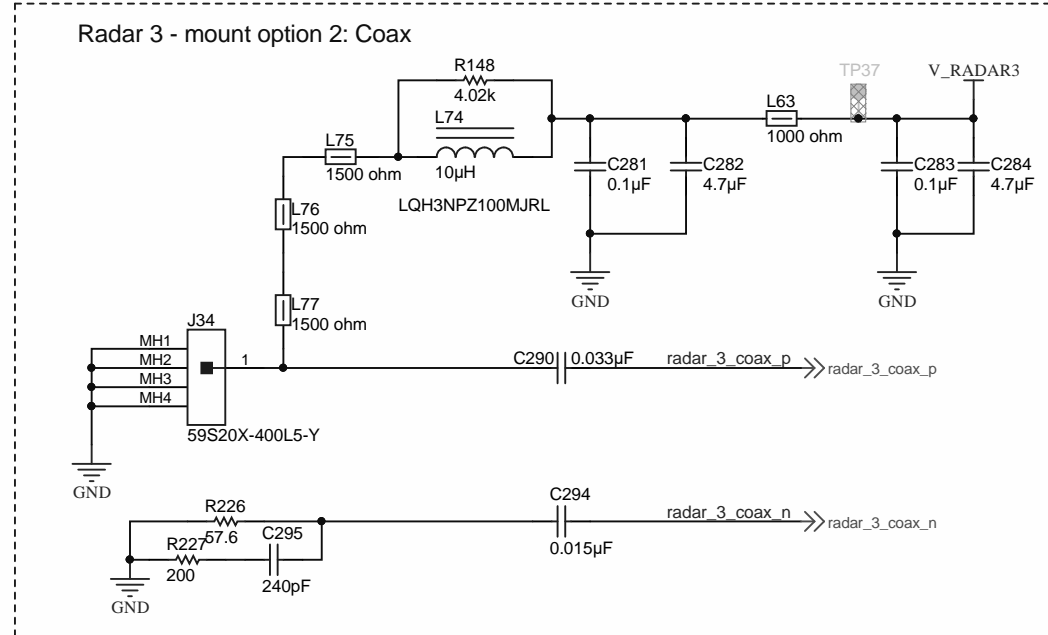
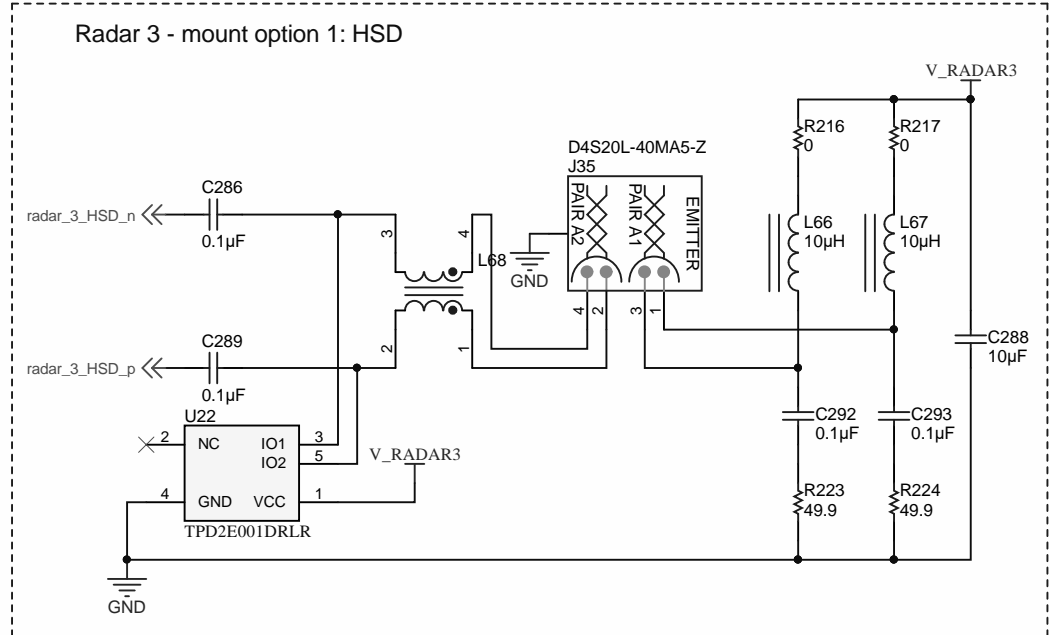
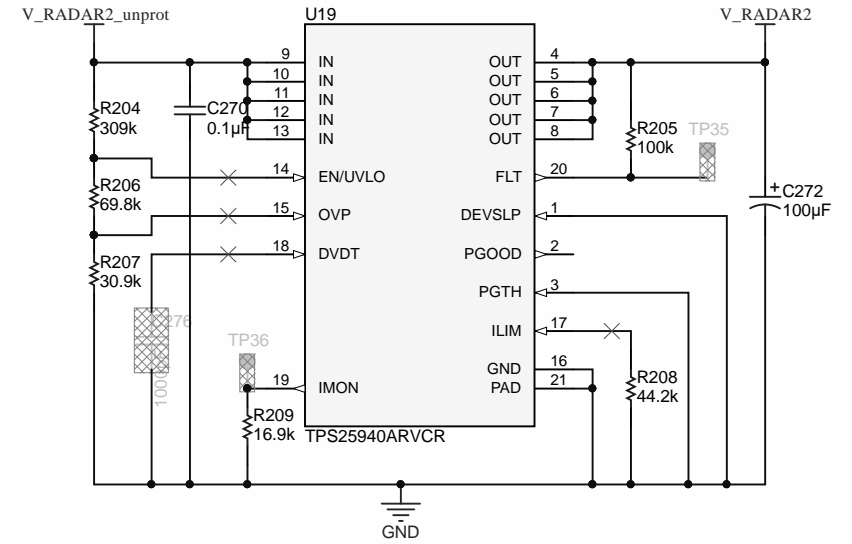
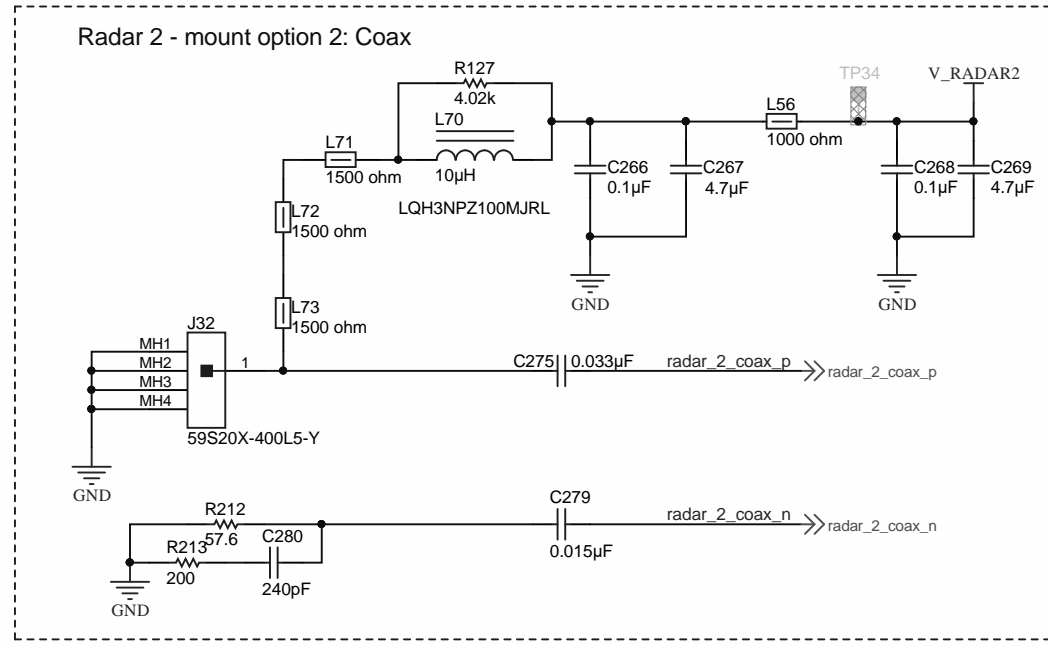
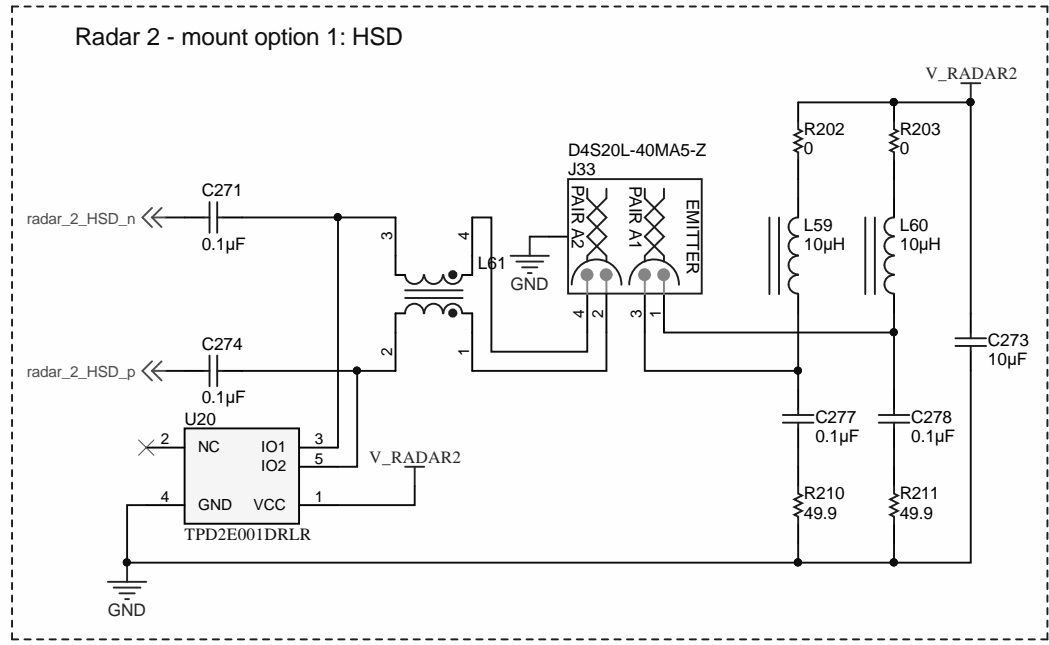

Texas Instruments and/or its licensors do not warrant the accuracy or completeness of this specification or any information contained therein. Texas Instruments and/or its licensors do not warrant that this design will meet the specifications, will be suitable for your application or fit for any particular purpose, or will operate in an implementation. Texas Instruments and/or its licensors do not warrant that the design is production worthy. You should completely validate and test your design implementation to confirm the system functionality for your application.

| | | |
|---------------------------------|----------------------------------------------------------------------------|---------------------|
| Orderable: EVM_orderable | Designed for: Public Release | Mod. Date: 1/5/2018 |
| TID #: N/A | Project Title: ADAS Sensor Fusion Board | |
| Number: 518520B | Rev: E3 | Sheet Title: |
| SVN Rev: Not in version control | Assembly Variant: Populated_variant | Sheet: 11 of 15 |
| Drawn By: | File: ADAS_SF_Data_Connection_Radar_02.SchDoc | Size: B |
| Engineer: Spectrum Digital | Contact: http://www.ti.com/support | |



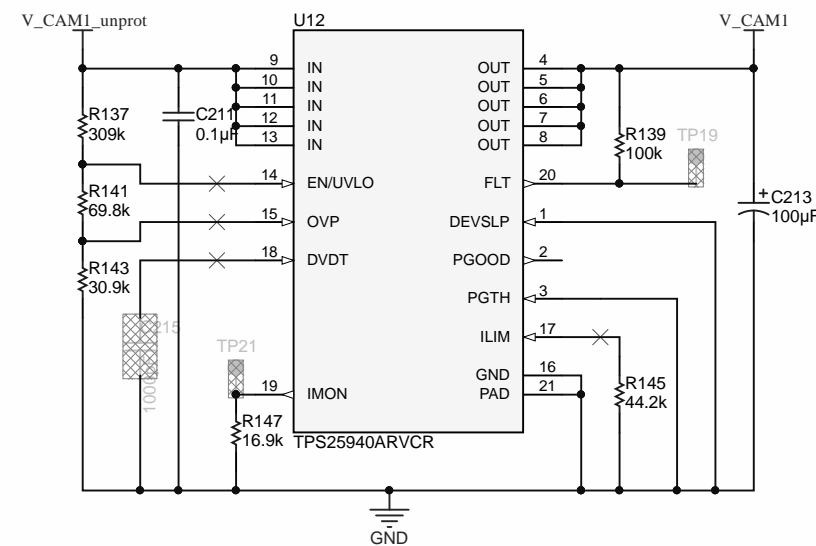
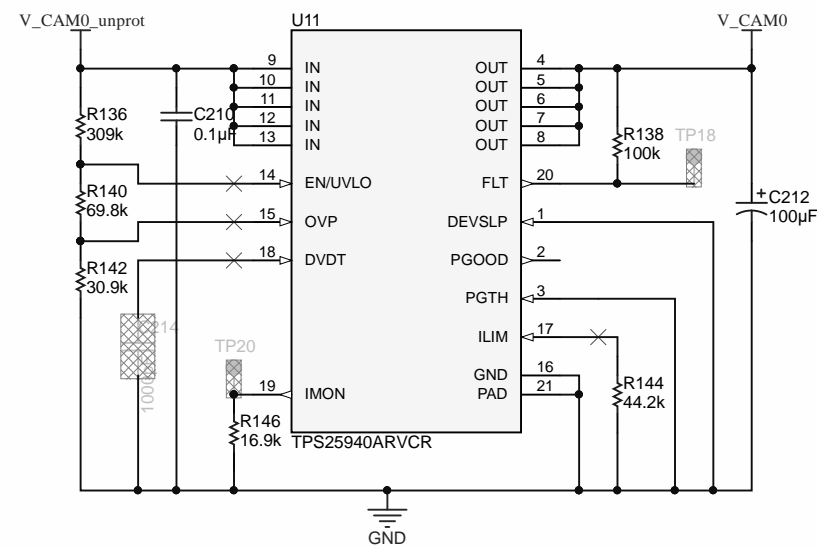
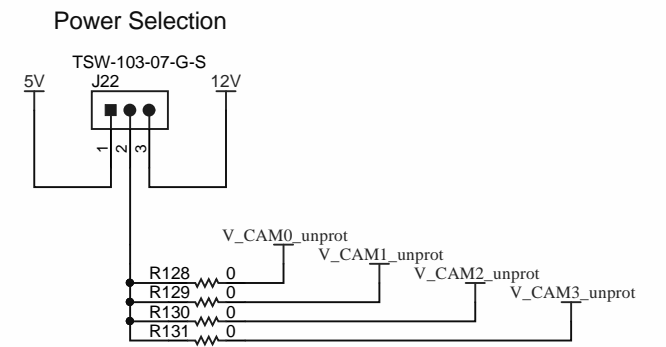
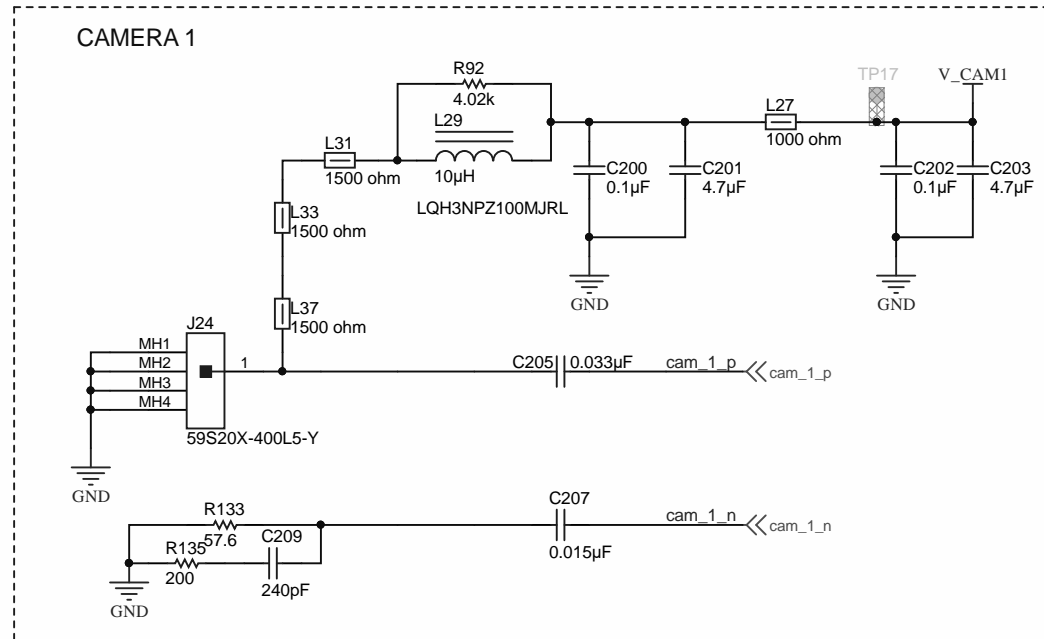
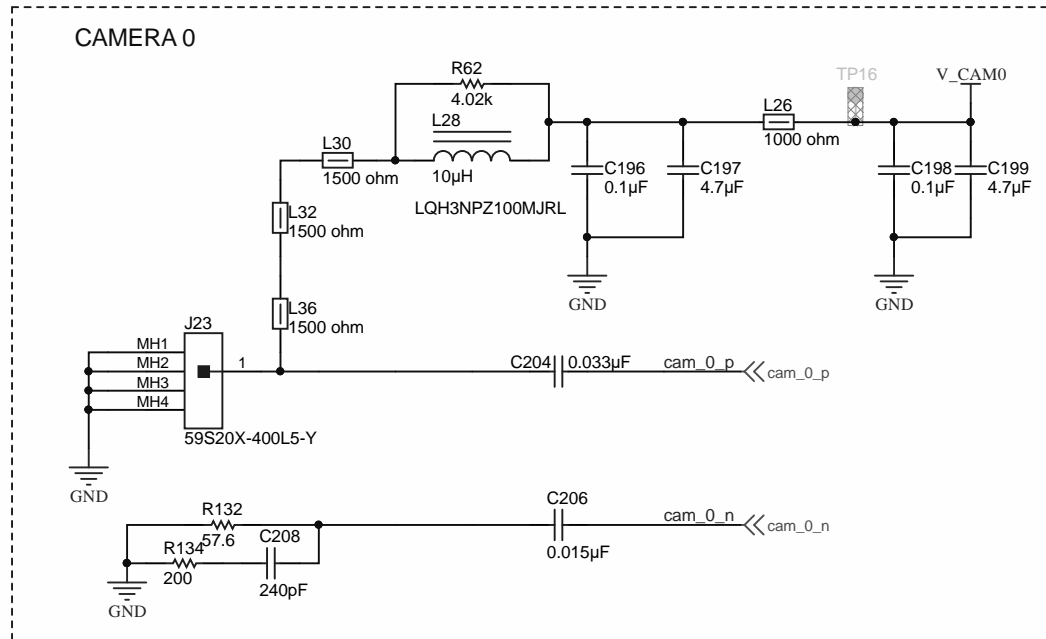

Texas Instruments and/or its licensors do not warrant the accuracy or completeness of this specification or any information contained therein. Texas Instruments and/or its licensors do not warrant that this design will meet the specifications, will be suitable for your application or fit for any particular purpose, or will operate in an implementation. Texas Instruments and/or its licensors do not warrant that the design is production worthy. You should completely validate and test your design implementation to confirm the system functionality for your application.

| | | |
|---------------------------------|---------------------------------------------|---------------------|
| Orderable: EVM_orderable | Designed for: Public Release | Mod. Date: 1/5/2018 |
| TID #: N/A | Project Title: ADAS Sensor Fusion Board | |
| Number: 518520B | Rev: E3 | Sheet Title: |
| SVN Rev: Not in version control | Assembly Variant: Populated_variant | Sheet: 12 of 15 |
| Drawn By: | File: ADAS_SF_Data_Connection_Cam_01.SchDoc | Size: B |
| Engineer: Spectrum Digital | Contact: http://www.ti.com/support | |



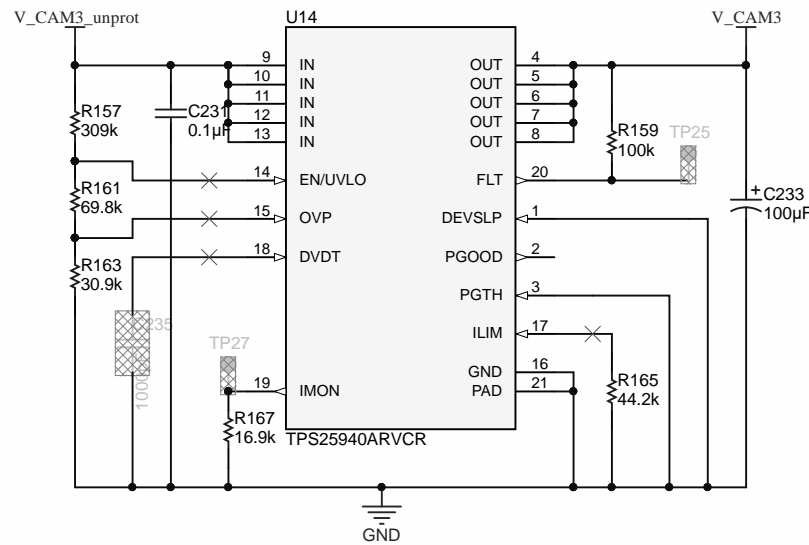
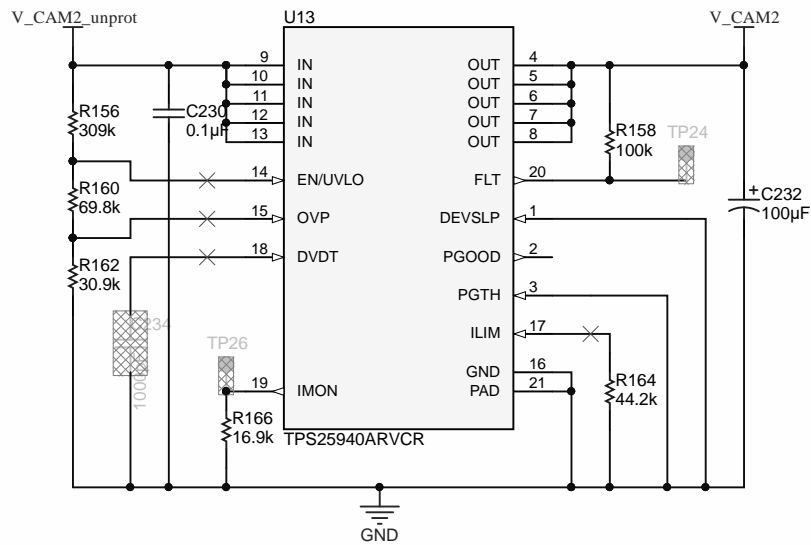
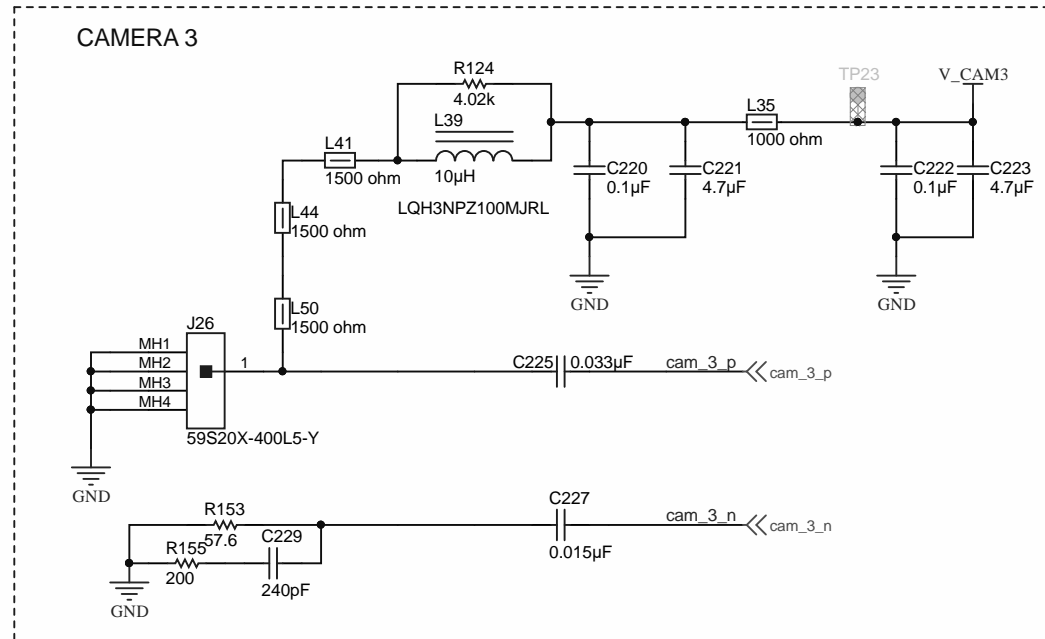
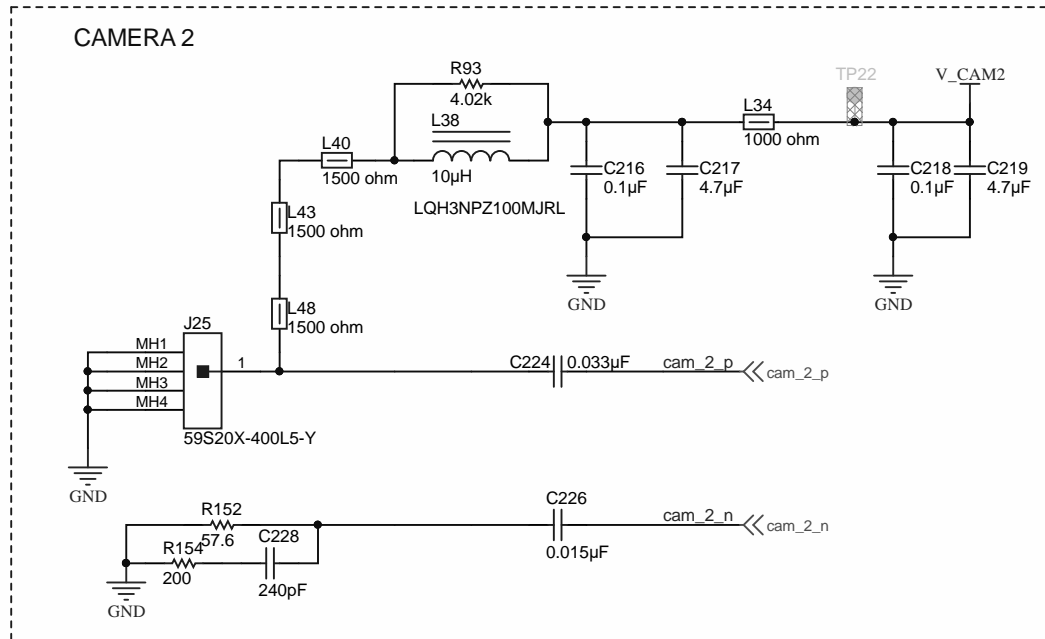

Texas Instruments and/or its licensors do not warrant the accuracy or completeness of this specification or any information contained therein. Texas Instruments and/or its licensors do not warrant that this design will meet the specifications, will be suitable for your application or fit for any particular purpose, or will operate in an implementation. Texas Instruments and/or its licensors do not warrant that the design is production worthy. You should completely validate and test your design implementation to confirm the system functionality for your application.

| | | |
|---------------------------------|----------------------------------------------------------------------------|---------------------|
| Orderable: EVM_orderable | Designed for: Public Release | Mod. Date: 1/5/2018 |
| TID #: N/A | Project Title: ADAS Sensor Fusion Board | |
| Number: 518520B | Rev: E3 | Sheet Title: |
| SVN Rev: Not in version control | Assembly Variant: Populated_variant | Sheet: 13 of 15 |
| Drawn By: | File: ADAS_SF_Data_Connection_Cam_02.SchDoc | Size: B |
| Engineer: Spectrum Digital | Contact: http://www.ti.com/support | |

A

A

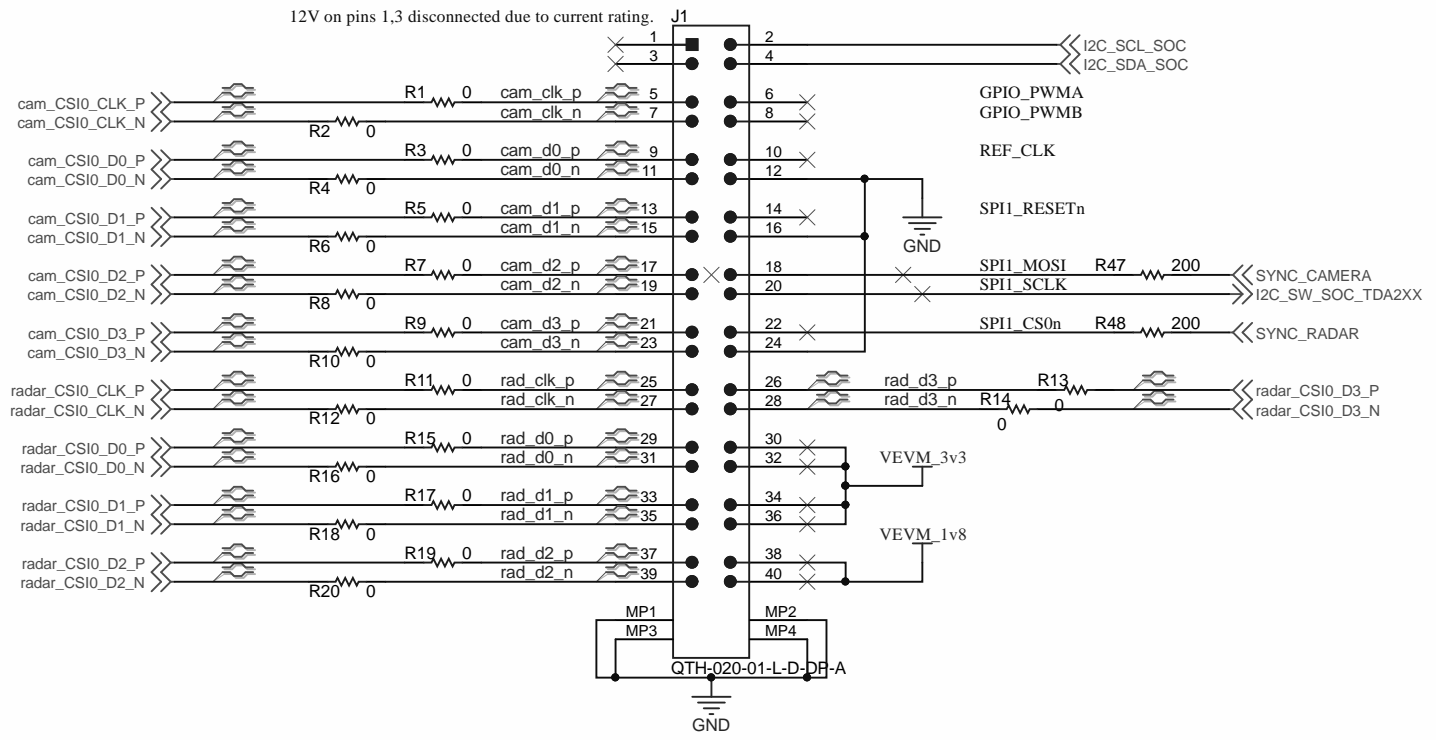
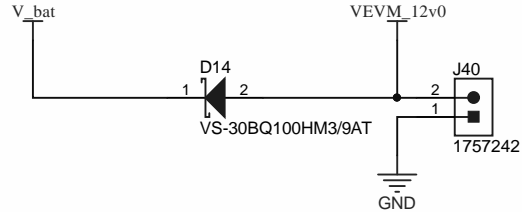

These signals are outputs on J6 ECO/Entry. On J6 Plus, they are bidirectional except for SCLK. PWM signals are only present on J6 Entry.

SPI1_CS0n - GPIO7_10
 SPI1_SCLK - GPIO7_7 (OUTPUT ONLY)
 SPI1_MOSI - GPIO7_9
 SPI1_MISO - GPIO7_8

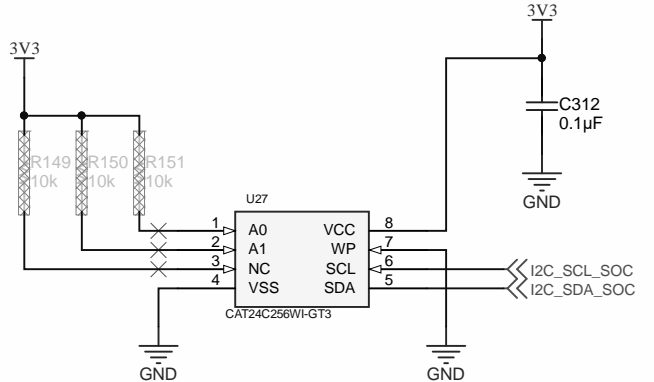

DEFAULT I2C 7-BIT ADDRESS 0x50

B

B

C

C

D

D

Texas Instruments and/or its licensors do not warrant the accuracy or completeness of this specification or any information contained therein. Texas Instruments and/or its licensors do not warrant that this design will meet the specifications, will be suitable for your application or fit for any particular purpose, or will operate in an implementation. Texas Instruments and/or its licensors do not warrant that the design is production worthy. You should completely validate and test your design implementation to confirm the system functionality for your application.

| | | |
|---------------------------------|----------------------------------------------------------------------------|----------------------|
| Orderable: EVM_orderable | Designed for: Public Release | Mod. Date: 8/25/2017 |
| TID #: N/A | Project Title: ADAS Sensor Fusion Board | |
| Number: 518520B | Rev: E3 | Sheet Title: |
| SVN Rev: Not in version control | Assembly Variant: Populated_variant | Sheet: 14 of 15 |
| Drawn By: | File: ADAS_SF_Data_CSI2_Connector.SchDoc | Size: B |
| Engineer: Spectrum Digital | Contact: http://www.ti.com/support | |



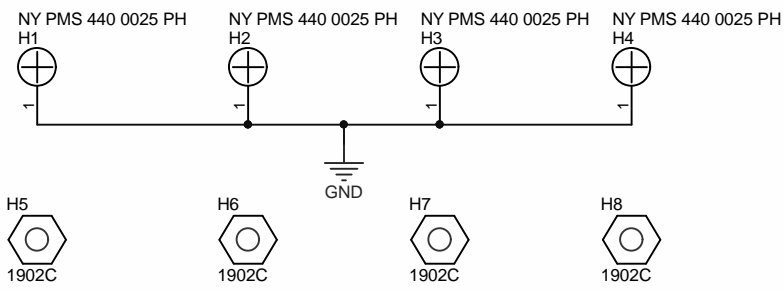

PCB Number: 518520B
PCB Rev: B

PCB LOGO
Texas Instruments

PCB LOGO
RoHS Exempt

PCB LOGO
FCC disclaimer

You should delete the nylon screws/standoffs and/or the bumpers as needed for your design (or substitute other parts from Hardware.IntLib). Bumpers are cheaper, but provide less clearance.

Deleting anything else from this page may result in your EVM submission being rejected (until you add them back).

Update the Label Text in the Label Table as needed for each Assembly Variant.

You should delete this note too.

| Variant/Label Table | |
|---------------------|------------|
| Variant | Label Text |
| 001 | ChangeMe! |
| 002 | ChangeMe! |
| | |
| | |
| | |
| | |
| | |

ZZ1
Label Assembly Note
This Assembly Note is for PCB labels only

ZZ2
Assembly Note
These assemblies are ESD sensitive, ESD precautions shall be observed.

ZZ3
Assembly Note
These assemblies must be clean and free from flux and all contaminants. Use of no clean flux is not acceptable.

ZZ4
Assembly Note
These assemblies must comply with workmanship standards IPC-A-610 Class 2, unless otherwise specified.

Texas Instruments and/or its licensors do not warrant the accuracy or completeness of this specification or any information contained therein. Texas Instruments and/or its licensors do not warrant that this design will meet the specifications, will be suitable for your application or fit for any particular purpose, or will operate in an implementation. Texas Instruments and/or its licensors do not warrant that the design is production worthy. You should completely validate and test your design implementation to confirm the system functionality for your application.

| | | |
|---------------------------------|-----------------------------------------|-----------------------|
| Orderable: EVM_orderable | Designed for: Public Release | Mod. Date: 10/19/2017 |
| TID #: N/A | Project Title: ADAS Sensor Fusion Board | |
| Number: 518520B | Rev: E3 | Sheet Title: |
| SVN Rev: Not in version control | Assembly Variant: Populated_variant | Sheet: 15 of 15 |
| Drawn By: | File: ADAS_SF_rev1_Hardware.SchDoc | Size: B |
| Engineer: Spectrum Digital | Contact: http://www.ti.com/support | |



IMPORTANT NOTICE FOR TI DESIGN INFORMATION AND RESOURCES

Texas Instruments Incorporated ("TI") technical, application or other design advice, services or information, including, but not limited to, reference designs and materials relating to evaluation modules, (collectively, "TI Resources") are intended to assist designers who are developing applications that incorporate TI products; by downloading, accessing or using any particular TI Resource in any way, you (individually or, if you are acting on behalf of a company, your company) agree to use it solely for this purpose and subject to the terms of this Notice.

TI's provision of TI Resources does not expand or otherwise alter TI's applicable published warranties or warranty disclaimers for TI products, and no additional obligations or liabilities arise from TI providing such TI Resources. TI reserves the right to make corrections, enhancements, improvements and other changes to its TI Resources.

You understand and agree that you remain responsible for using your independent analysis, evaluation and judgment in designing your applications and that you have full and exclusive responsibility to assure the safety of your applications and compliance of your applications (and of all TI products used in or for your applications) with all applicable regulations, laws and other applicable requirements. You represent that, with respect to your applications, you have all the necessary expertise to create and implement safeguards that (1) anticipate dangerous consequences of failures, (2) monitor failures and their consequences, and (3) lessen the likelihood of failures that might cause harm and take appropriate actions. You agree that prior to using or distributing any applications that include TI products, you will thoroughly test such applications and the functionality of such TI products as used in such applications. TI has not conducted any testing other than that specifically described in the published documentation for a particular TI Resource.

You are authorized to use, copy and modify any individual TI Resource only in connection with the development of applications that include the TI product(s) identified in such TI Resource. NO OTHER LICENSE, EXPRESS OR IMPLIED, BY ESTOPPEL OR OTHERWISE TO ANY OTHER TI INTELLECTUAL PROPERTY RIGHT, AND NO LICENSE TO ANY TECHNOLOGY OR INTELLECTUAL PROPERTY RIGHT OF TI OR ANY THIRD PARTY IS GRANTED HEREIN, including but not limited to any patent right, copyright, mask work right, or other intellectual property right relating to any combination, machine, or process in which TI products or services are used. Information regarding or referencing third-party products or services does not constitute a license to use such products or services, or a warranty or endorsement thereof. Use of TI Resources may require a license from a third party under the patents or other intellectual property of the third party, or a license from TI under the patents or other intellectual property of TI.

TI RESOURCES ARE PROVIDED "AS IS" AND WITH ALL FAULTS. TI DISCLAIMS ALL OTHER WARRANTIES OR REPRESENTATIONS, EXPRESS OR IMPLIED, REGARDING TI RESOURCES OR USE THEREOF, INCLUDING BUT NOT LIMITED TO ACCURACY OR COMPLETENESS, TITLE, ANY EPIDEMIC FAILURE WARRANTY AND ANY IMPLIED WARRANTIES OF MERCHANTABILITY, FITNESS FOR A PARTICULAR PURPOSE, AND NON-INFRINGEMENT OF ANY THIRD PARTY INTELLECTUAL PROPERTY RIGHTS.

TI SHALL NOT BE LIABLE FOR AND SHALL NOT DEFEND OR INDEMNIFY YOU AGAINST ANY CLAIM, INCLUDING BUT NOT LIMITED TO ANY INFRINGEMENT CLAIM THAT RELATES TO OR IS BASED ON ANY COMBINATION OF PRODUCTS EVEN IF DESCRIBED IN TI RESOURCES OR OTHERWISE. IN NO EVENT SHALL TI BE LIABLE FOR ANY ACTUAL, DIRECT, SPECIAL, COLLATERAL, INDIRECT, PUNITIVE, INCIDENTAL, CONSEQUENTIAL OR EXEMPLARY DAMAGES IN CONNECTION WITH OR ARISING OUT OF TI RESOURCES OR USE THEREOF, AND REGARDLESS OF WHETHER TI HAS BEEN ADVISED OF THE POSSIBILITY OF SUCH DAMAGES.

You agree to fully indemnify TI and its representatives against any damages, costs, losses, and/or liabilities arising out of your non-compliance with the terms and provisions of this Notice.

This Notice applies to TI Resources. Additional terms apply to the use and purchase of certain types of materials, TI products and services. These include; without limitation, TI's standard terms for semiconductor products (<http://www.ti.com/sc/docs/stdterms.htm>), [evaluation modules](#), and [samples](http://www.ti.com/sc/docs/sampterm.htm) (<http://www.ti.com/sc/docs/sampterm.htm>).

Mailing Address: Texas Instruments, Post Office Box 655303, Dallas, Texas 75265
Copyright © 2018, Texas Instruments Incorporated