

Charging Supercapacitor Banks from USB Type C Port With Boost Converter

Helen Chen

Boost Converter and Controller Solutions

ABSTRACT

The maximum allowed output current from the USB type C port is 5V3A by default. Most of the boost converter cannot limit the input current below 3A when charging big capacitance. Because when charging a big capacitance, it will take a relatively long time before the output voltage reaches the input voltage. The boost converter works with maximum duty. So the input current is uncontrollable and will rise to a very high value during this period. This application note gives out a simple, reliable and low cost solution for the big capacitance charge circuit. It is especially fit for the USB type C port supplied system as the input current can be well limited below 3A. The charging speed can be adjusted by using different fly-back transformers. It is also fit for some critical applications where the input current need to be limited below 200-500mA by choosing a small current rating boost converter.

Contents

1	Introduction	1
2	Device Overview	2
3	Test Results	3

List of Figures

1	Application Schematic.....	2
2	Waveforms of V_O , I_{IN} at NP/NS=0.25	3
3	Waveforms of V_O , I_{IN} at NP/NS=0.6	3
4	Waveforms of V_O and the Charge Current into the Supercapacitor (NP/NS=0.25)	3
5	Waveforms of V_O and the Charge Current into the Supercapacitor (NP/NS=0.6).....	3

List of Tables

1	Performance Specification Summary	2
---	---	---

Trademarks

All trademarks are the property of their respective owners.

1 Introduction

There are various methodologies on how to charge a big cap like super capacitor (SC). Constant current and constant voltage (CICV) is one of the most commonly used and preferred solution. At the beginning of the charging cycle, the charging device charges the SC with a constant current. When the SC is charged to the target value, constant voltage loop becomes active and prevent the SC from over charging. This kind of charging IC, especially the boost charging IC is less common and much expensive than the normal boost converter.

This application note delivers a very simple and low cost solution on how to charge the SC banks from a USB type C port. By choosing an appropriate boost converter and connecting it in the fly-back topology, the input current can be effectively limited below 3A. The maximum charge current into the SC banks is also limited below a certain value, which can reduce the heat generation and extend the life of SC.

2 Device Overview

2.1 Specification

Table 1 shows the specification of this application report. The maximum input current is limited below 3A during the startup and during the normal operation.

Table 1. Performance Specification Summary

PARAMETER	TEST CONDITIONS	MIN	TYP	MAX	UNIT
V _{IN}	Input Voltage	4.5	5.0	5.5	V
I _{IN_peak}	Peak Input Current	Anytime during charging the SC banks			A
V _{SC_target}	The voltage across the SC banks after fully charged	V _{IN} =5V			V

2.2 Schematic

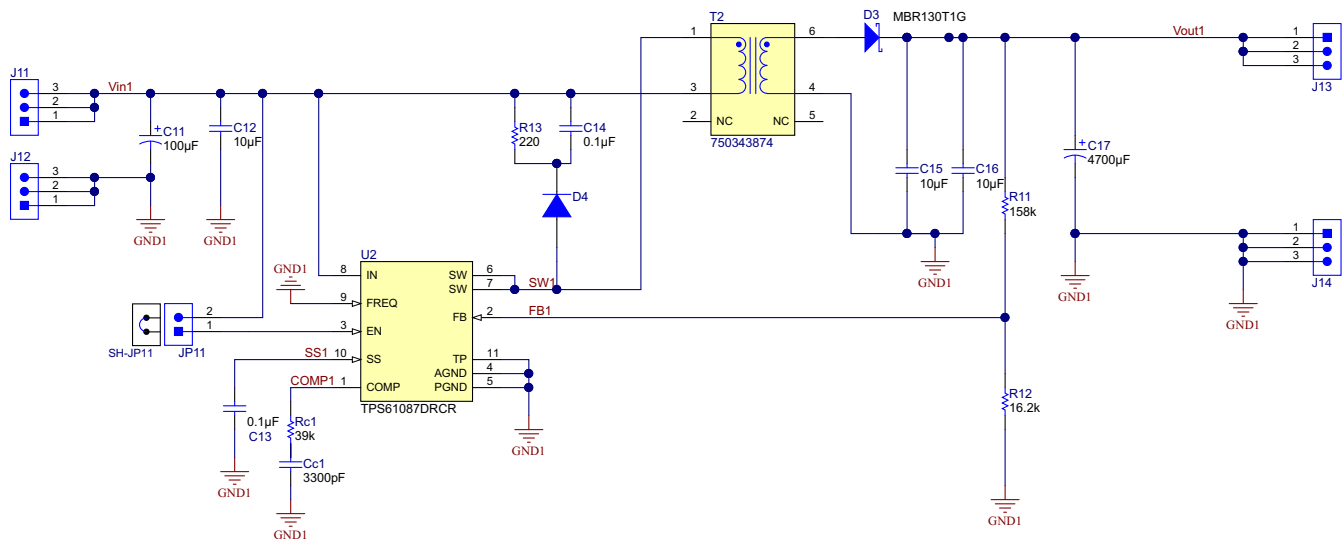

Figure 1. Application Schematic

Figure 1 shows the schematic for this application report. The circuit is of fly-back topology. The boost converter, TPS61087, always works at the current-limit mode during start-up before the output voltage reaches the target value. The peak primary inductor current is limited at the peak current limit point of TPS61087, which is around 4A. Accordingly, the peak secondary inductor current is limited at the primary current times the transformer turns ratio. After the output capacitor is fully charged, the TPS61087 device works in the skip mode.

2.3 Parameter Calculation

The maximum allowable turns ratio NP/NS is determined by the input voltage (V_{IN}), output voltage (V_O), and the maximum switch node voltage (V_{SWmax}).

$$N_{\max} = \frac{N_P}{N_S} = \frac{V_{SW\max} - V_{IN}}{V_O}$$

where

- V_O=13.5V
- V_{IN}=5V

(1)

If we set the maximum switch node voltage V_{SWmax} at 14V, which is 70% of the absolute maximum rating voltage, then the maximum turns ratio $N_{max} = 0.65$. So the turns ratio of the flyback transformer should be lower than this value to meet the design target. Larger inductance means larger inductor size. In AN SLVA981, TPS61087 works in the DCM and CCM boundary when the output voltage reaches the target value. So the inductance will be neither too large nor too small.

If NP/NS=0.25, the maximum duty cycle D_{max1} can be calculated with [Equation 2](#).

$$D_{max1} = \frac{0.25 \cdot V_O}{0.25 \cdot V_O + \eta \cdot V_{in}} \approx 0.44$$

where

- η is the conversion efficiency, $\eta=0.85$ (2)

If NP/NS=0.6, the maximum duty cycle, D_{max2} , can be calculated with [Equation 3](#).

$$D_{max2} = \frac{0.6 \cdot V_O}{0.6 \cdot V_O + \eta \cdot V_{in}} \approx 0.66$$
 (3)

As the TPS61087 works in the current limit mode, so the maximum average input current under different duty cycle is different. The typical current limit value I_{LIM} of TPS61087 is 4A according to the datasheet. So the maximum average input current under different turns ratio can be calculated by the following equation:

$$I_{IN_1} = I_{LIM} \cdot \frac{D_{max1}}{2} = 0.88A$$
 (4)

$$I_{IN_2} = I_{LIM} \cdot \frac{D_{max2}}{2} = 1.32A$$
 (5)

The current limit value I_{LIM} has $\pm 20\%$ tolerance, so the average input current will also has $\pm 20\%$ tolerance.

The secondary current is determined by the primary current limit I_{LIM} times the turns ratio. So the maximum charge current under different turns ratio is:

$$I_{charge_sup1} = I_{LIM} \cdot 0.25 = 1A$$
 (6)

$$I_{charge_sup2} = I_{LIM} \cdot 0.6 = 2.4A$$
 (7)

So the transformer turns ratio can be chosen according to the maximum current rating of the supercapacitor.

3 Test Results

[Figure 2](#) and [Figure 3](#) show the waveforms of the output voltage VO and the input current IIN during charging a 70mF cap. When the turns ratio is 0.25, the charging period is around 2.2 seconds; when the turns ratio is 0.6, the charging period is around 1.2 seconds.

[Figure 4](#) and [Figure 5](#) show the waveforms of the current flowing into the output cap during charging up. The charging current is larger with a larger turns ratio transformer as shown in these waveforms.

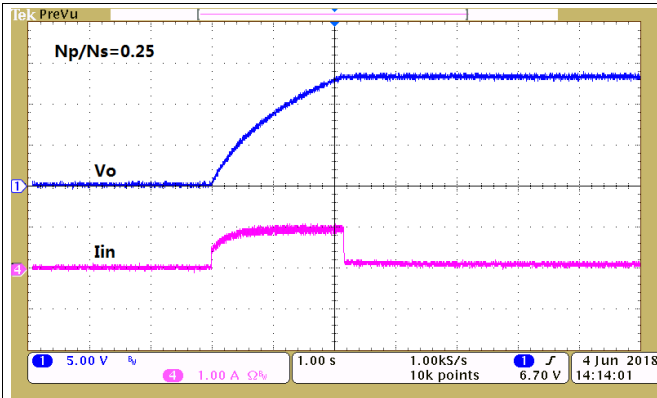

Figure 2. Waveforms of V_o , I_{IN} at NP/NS=0.25

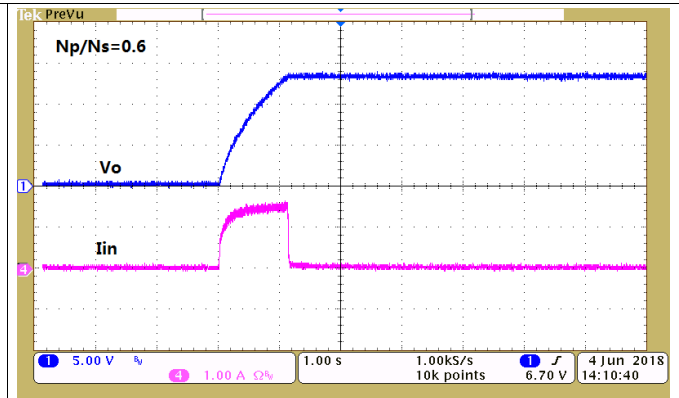

Figure 3. Waveforms of V_o , I_{IN} at NP/NS=0.6

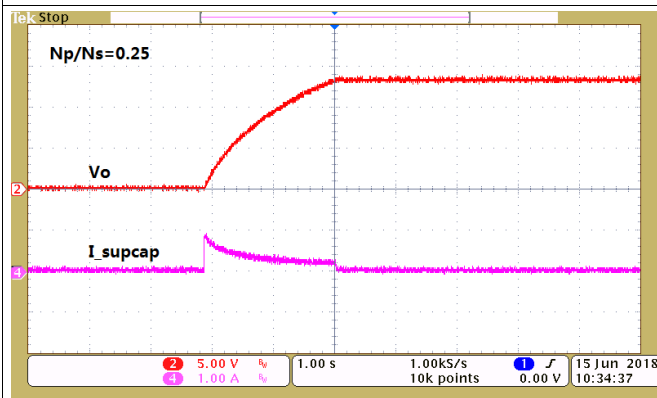

Figure 4. Waveforms of V_o and the Charge Current into the Supercapacitor (NP/NS=0.25)

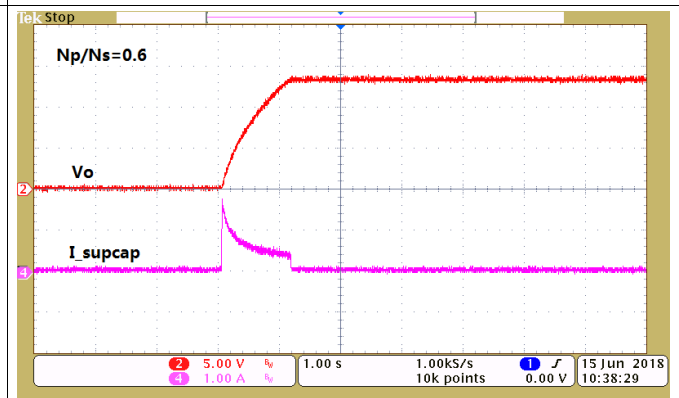

Figure 5. Waveforms of V_o and the Charge Current into the Supercapacitor (NP/NS=0.6)

IMPORTANT NOTICE FOR TI DESIGN INFORMATION AND RESOURCES

Texas Instruments Incorporated ("TI") technical, application or other design advice, services or information, including, but not limited to, reference designs and materials relating to evaluation modules, (collectively, "TI Resources") are intended to assist designers who are developing applications that incorporate TI products; by downloading, accessing or using any particular TI Resource in any way, you (individually or, if you are acting on behalf of a company, your company) agree to use it solely for this purpose and subject to the terms of this Notice.

TI's provision of TI Resources does not expand or otherwise alter TI's applicable published warranties or warranty disclaimers for TI products, and no additional obligations or liabilities arise from TI providing such TI Resources. TI reserves the right to make corrections, enhancements, improvements and other changes to its TI Resources.

You understand and agree that you remain responsible for using your independent analysis, evaluation and judgment in designing your applications and that you have full and exclusive responsibility to assure the safety of your applications and compliance of your applications (and of all TI products used in or for your applications) with all applicable regulations, laws and other applicable requirements. You represent that, with respect to your applications, you have all the necessary expertise to create and implement safeguards that (1) anticipate dangerous consequences of failures, (2) monitor failures and their consequences, and (3) lessen the likelihood of failures that might cause harm and take appropriate actions. You agree that prior to using or distributing any applications that include TI products, you will thoroughly test such applications and the functionality of such TI products as used in such applications. TI has not conducted any testing other than that specifically described in the published documentation for a particular TI Resource.

You are authorized to use, copy and modify any individual TI Resource only in connection with the development of applications that include the TI product(s) identified in such TI Resource. NO OTHER LICENSE, EXPRESS OR IMPLIED, BY ESTOPPEL OR OTHERWISE TO ANY OTHER TI INTELLECTUAL PROPERTY RIGHT, AND NO LICENSE TO ANY TECHNOLOGY OR INTELLECTUAL PROPERTY RIGHT OF TI OR ANY THIRD PARTY IS GRANTED HEREIN, including but not limited to any patent right, copyright, mask work right, or other intellectual property right relating to any combination, machine, or process in which TI products or services are used. Information regarding or referencing third-party products or services does not constitute a license to use such products or services, or a warranty or endorsement thereof. Use of TI Resources may require a license from a third party under the patents or other intellectual property of the third party, or a license from TI under the patents or other intellectual property of TI.

TI RESOURCES ARE PROVIDED "AS IS" AND WITH ALL FAULTS. TI DISCLAIMS ALL OTHER WARRANTIES OR REPRESENTATIONS, EXPRESS OR IMPLIED, REGARDING TI RESOURCES OR USE THEREOF, INCLUDING BUT NOT LIMITED TO ACCURACY OR COMPLETENESS, TITLE, ANY EPIDEMIC FAILURE WARRANTY AND ANY IMPLIED WARRANTIES OF MERCHANTABILITY, FITNESS FOR A PARTICULAR PURPOSE, AND NON-INFRINGEMENT OF ANY THIRD PARTY INTELLECTUAL PROPERTY RIGHTS.

TI SHALL NOT BE LIABLE FOR AND SHALL NOT DEFEND OR INDEMNIFY YOU AGAINST ANY CLAIM, INCLUDING BUT NOT LIMITED TO ANY INFRINGEMENT CLAIM THAT RELATES TO OR IS BASED ON ANY COMBINATION OF PRODUCTS EVEN IF DESCRIBED IN TI RESOURCES OR OTHERWISE. IN NO EVENT SHALL TI BE LIABLE FOR ANY ACTUAL, DIRECT, SPECIAL, COLLATERAL, INDIRECT, PUNITIVE, INCIDENTAL, CONSEQUENTIAL OR EXEMPLARY DAMAGES IN CONNECTION WITH OR ARISING OUT OF TI RESOURCES OR USE THEREOF, AND REGARDLESS OF WHETHER TI HAS BEEN ADVISED OF THE POSSIBILITY OF SUCH DAMAGES.

You agree to fully indemnify TI and its representatives against any damages, costs, losses, and/or liabilities arising out of your non-compliance with the terms and provisions of this Notice.

This Notice applies to TI Resources. Additional terms apply to the use and purchase of certain types of materials, TI products and services. These include; without limitation, TI's standard terms for semiconductor products (<http://www.ti.com/sc/docs/stdterms.htm>), [evaluation modules](#), and [samples](http://www.ti.com/sc/docs/sampterm.htm) (<http://www.ti.com/sc/docs/sampterm.htm>).

Mailing Address: Texas Instruments, Post Office Box 655303, Dallas, Texas 75265
Copyright © 2018, Texas Instruments Incorporated