

ABSTRACT

This user's guide describes the characteristics, operation, and use of the INA2290 evaluation module (EVM). This EVM is designed to evaluate the performance of the INA2290 voltage-output, current shunt monitor in a variety of configurations. Throughout this document, the terms evaluation board, evaluation module, and EVM are synonymous with the INA2290EVM. This document also includes a schematic, reference printed-circuit board (PCB) layouts, and a complete bill of materials (BOM).

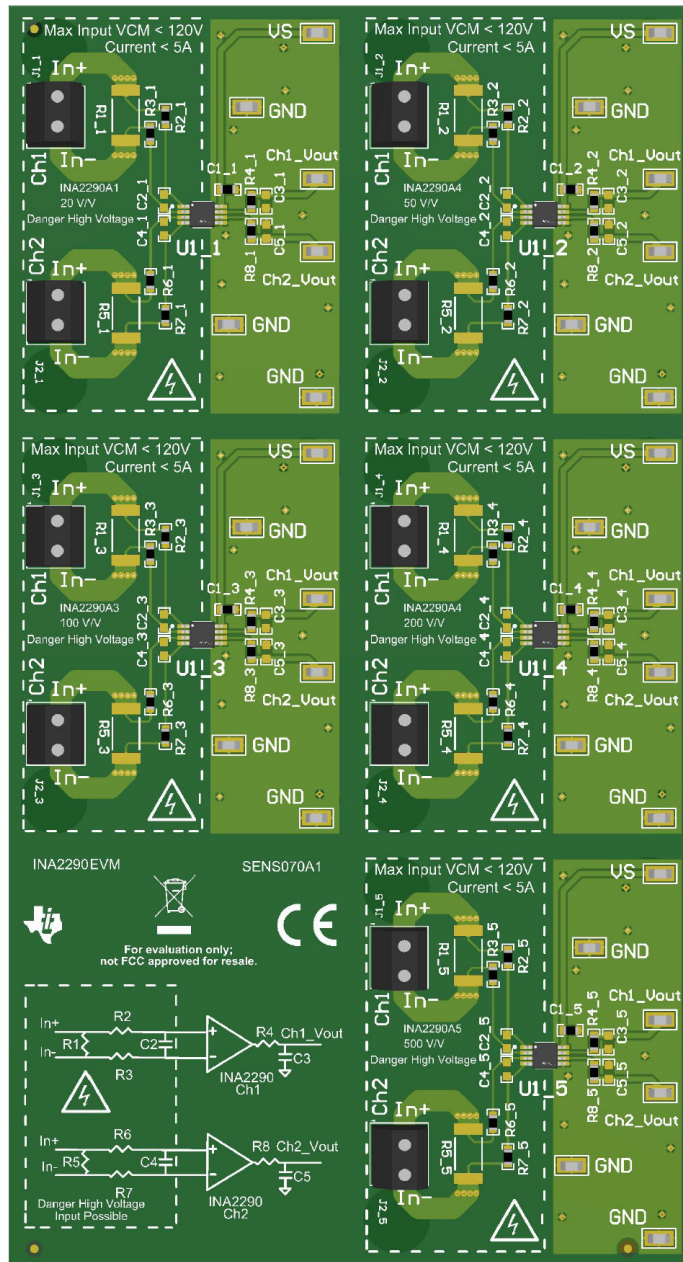

Table of Contents

1 General Texas Instruments High Voltage Evaluation (TI HV EVM) User Safety Guidelines	3
2 Overview	4
2.1 EVM Kit Contents.....	4
2.2 Related Documentation From Texas Instruments.....	4
3 Hardware	5
3.1 Features.....	5
4 Operation	6
4.1 Quick Start Setup.....	6
4.2 Measurements.....	6
5 EVM Components	7
5.1 R2_n, R3_n, R4_n, R6_n, R7_n, R8_n, C2_n, C3_n, C4_n, C5_n.....	7
5.2 C1_An.....	7
5.3 R1_n, R5_n (Rshunt).....	7
5.4 U1_n (INA2290).....	7
6 Schematic, PCB Layout, and Bill of Materials	8
6.1 Schematics.....	8
6.2 PCB Layout.....	11
6.3 Bill of Materials.....	15
7 Revision History	17

List of Figures

Figure 6-1. INA2290EVM Schematic: Gain A1 Panel.....	8
Figure 6-2. INA2290EVM Schematic: Gain A2 Panel.....	9
Figure 6-3. INA2290EVM Schematic: Gain A3 Panel.....	9
Figure 6-4. INA2290EVM Schematic: Gain A4 Panel.....	10
Figure 6-5. INA2290EVM Schematic: Gain A5 Panel.....	10
Figure 6-6. INA2290EVM Top Overlay.....	11
Figure 6-7. INA2290EVM Bottom Overlay.....	11
Figure 6-8. INA2290EVM Top Layer.....	12
Figure 6-9. INA2290EVM Bottom Layer.....	12
Figure 6-10. INA2290EVM Top Solder.....	13
Figure 6-11. INA2290EVM Bottom Solder.....	13
Figure 6-12. INA2290EVM Drill Drawing.....	14

List of Tables

Table 2-1. INA2290 Gain Option Summary.....	4
Table 2-2. INA2290EVM Kit Contents.....	4
Table 2-3. Related Documentation.....	4
Table 6-1. Bill of Materials.....	15

Trademarks

All trademarks are the property of their respective owners.

1 General Texas Instruments High Voltage Evaluation (TI HV EVM) User Safety Guidelines



Always follow TI's setup and application instructions, including use of all interface components within their recommended electrical rated voltage and power limits. Always use electrical safety precautions to help ensure your personal safety and those working around you. Contact TI's Product Information Center <http://support/ti.com> for further information.

Save all warnings and instructions for future reference.

WARNING

Failure to follow warnings and instructions may result in personal injury, property damage or death due to electrical shock and burn hazards.

The term TI HV EVM refers to an electronic device typically provided as an open-framed, unenclosed printed-circuit board assembly. It is intended strictly for use in development laboratory environments, solely for qualified professional users having training, expertise, and knowledge of electrical safety risks in development and application of high-voltage electrical circuits. Any other use and/or application are strictly prohibited by Texas Instruments. If you are not suitable-qualified, you should immediately stop from further use of the HV EVM.

1. Work Area Safety

- a. Keep work area clean and orderly.
- b. Qualified observer(s) must be present anytime circuits are energized.
- c. Effective barriers and signage must be present in the area where the TI HV EVM and its interface electronics are energized, indicating operation of accessible high voltages may be present, for the purpose of protecting inadvertent access.
- d. All interface circuits, power supplies, evaluation modules, instruments, meters, scopes and other related apparatus used in a development environment exceeding 50Vrms/75VDC must be electrically located within a protected Emergency Power Off EPO protected power strip.
- e. Use stable and nonconductive work surface.
- f. Use adequately insulated clamps and wires to attach measurement probes and instruments. No freehand testing whenever possible.

2. Electrical Safety

As a precautionary measure, it is always a good engineering practice to assume that the entire EVM may have fully accessible and active high voltages.

- a. De-energize the TI HV EVM and all its inputs, outputs, and electrical loads before performing any electrical or other diagnostic measurements. Revalidate that TI HV EVM power has been safely de-energized.
- b. With the EVM confirmed de-energized, proceed with required electrical circuit configurations, wiring, measurement equipment connection, and other application needs, while still assuming the EVM circuit and measuring instruments are electrically live.
- c. After EVM readiness is complete, energize the EVM as intended.

WARNING

While the EVM is energized, never touch the EVM or its electrical circuits, as they could be at high voltages capable of causing electrical shock hazard.

3. Personal Safety

- a. Wear personal protective equipment (for example, latex gloves or safety glasses with side shields) or protect the EVM in an adequate lucent plastic box with interlocks to protect from accidental touch.

Limitation for safe use:

EVMs are not to be used as all or part of a production unit.

2 Overview

The INA2290 device is a voltage-output, high-side dual channel current sense amplifier in a VSSOP (8) package. As shown in [Table 2-1](#), the INA2290 has gains that range from 20 V/V to 500 V/V, depending on the gain option that is selected. The voltage developed across the device inputs is amplified by the corresponding gain of the specific device, and is presented at the output pin. The device can accurately sense voltage drops across shunts at 2.7-V to +120-V common-mode voltages, dependent of supply voltages. The device survives common-mode voltages from –20 V to +122 V. The device operates with supply voltages between 2.7 V and 20 V, and draws a typical of 350 μ A per channel at room temperature.

Table 2-1. INA2290 Gain Option Summary

Product ⁽¹⁾	Gain (V/V)
INA2290A1	20
INA2290A2	50
INA2290A3	100
INA2290A4	200
INA2290A5	500

(1) INA2290 is a preview device.

2.1 EVM Kit Contents

[Table 2-2](#) summarizes the contents of the INA2290EVM kit. Contact the nearest [Texas Instruments Product Information Center](#) if any component is missing. TI also recommends to check the [INA2290-Q1 device product folder](#) at www.ti.com for any further information regarding this product.

Table 2-2. INA2290EVM Kit Contents

Item	Item Part Number	Quantity
INA2290EVM test board	INA2290EVM	1

2.2 Related Documentation From Texas Instruments

This document provides information regarding Texas Instruments' integrated circuits used in the assembly of the INA2290EVM.

Table 2-3. Related Documentation

Document	Literature Number
INAx290 product data sheet	SBOS961
INA290-Q1 product data sheet	SBOS995

3 Hardware

The INA2290EVM provides a basic functional evaluation of the INA2290. The fixture layout is not intended to be a model for the target circuit, nor is it laid out for electromagnetic compatibility (EMC) testing. The INA2290EVM is one PCB with five optional PCB cutouts the engineer can use to test each of the five gain options (1 to 5) listed in [Table 2-1](#). Each PCB cutout has one INA2290An device (where n is 1, 2, 3, 4, or 5), test points and sockets for external hardware connections, and pads to solder down optional circuitry.

3.1 Features

The INA2290EVM PCB provides the following features:

- Evaluation of all gain options through provided device boards
- Ease of access to device pins with test points
- Pads and sockets for optional filtering at the input pins and output pin
- Multiple input signal options, including a method to solder a shunt resistor (2512) and safely measure current up to 5 A.

See the [device data sheet](#) for comprehensive information about the INA2290 and the available gain options.

4 Operation

4.1 Quick Start Setup

Follow these procedures to set up and use one of the INA2290EVM panels. For these instructions, n is gain option 1, 2, 3, 4, or 5.

1. Choose the desired gain option panel variation.
2. Connect an external DC supply voltage (between 2.7 V and 20 V) to a VS test point. Connect the ground reference of that supply to a GND test point on the same panel.
3. Provide a differential input voltage signal to the In+ and In– nodes by connecting the signal leads to the J1_n pin 1 and J1_n pin 2 for channel 1 or J2_n pin 1 and J2_n pin 2 for channel 2 on the EVM, as explained in [Section 4.2](#). The INA2290 is a unidirectional current-sensing device because there is no reference pin. The device can only measure current in one direction.

4.2 Measurements

The user can either emulate the voltage developed across a sense resistor based on a given set of system conditions with the INA2290EVM, or connect the device inputs to an external shunt. The user can also solder a surface-mount technology (SMT) shunt resistor across the In+ and In– pads, and these inputs can be connected in series with the external system and load. In+ and In– will refer the input of either channel being measured. J1_n for channel 1 and J2_n for channel 2. Also shunt resistor is R1_n for channel 1 and R5_n for channel 2 and will be referred to as Rshunt.

To configure a measurement evaluation without a shunt resistor, follow this procedure:

1. Connect a positive differential voltage across the In+ and In– tab. Given the internal GND reference of the device, make sure that the In+ pin is the more positive of the two inputs.
2. Connect a 2.7-V to 120-V common-mode voltage to the inputs if the differential voltage supply is a floating supply. Connect the positive lead of the external voltage source to the In– tab and source ground to a GND test point. The minimum common-mode voltage should be $>V_S$. This action effectively raises the absolute common-mode voltage of the input pins, while still retaining a positive input differential signal.
3. Measure the output voltage at the Vout test point with respect to GND.

To configure a measurement evaluation with a shunt resistor, follow this procedure:

1. Solder a 2512 resistor at the Rshunt pads that connects the In+ and In– inputs.
2. Connect the In+ and In– tabs in series with the load and bus voltage sources while powered off.

WARNING

Make sure that the equipment (shunt resistor, wires, connectors, and so on) can support the amperage and power dissipation first before you measure the current. Also make sure that the current flowing through J1 or J2 does not exceed 5 A. Failure to do so can result in hot surfaces ($> 55\text{ }^{\circ}\text{C}$), damage to the EVM, or personal injury.

3. Power on the system and measure the output voltage at the Vout test point for the correct channel. Vout is equal to the gain of the device multiplied by the differential voltage measured directly at the device input pins.

5 EVM Components

This section summarizes the INA2290EVM components. For these instructions, n is gain option 1, 2, 3, 4, or 5.

5.1 R2_n, R3_n, R4_n, R6_n, R7_n, R8_n, C2_n, C3_n, C4_n, C5_n

R2_n, R3_n, R4_n, R6_n, R7_n, R8_n are factory-installed 0-Ω 0603 resistors.

C2_n, C3_n, C4_n, C5_n are not populated.

Collectively, these pads allow user-defined filters for the input pins (IN+ and IN–) and the output pin (OUT) of the INA2290. If a filter is desired, remove these resistors and replace them with > 0-Ω SMT resistors and populate the capacitor pads with capacitors. Consider the input bias current of the device when using input filtering.

5.2 C1_An

C1_An is a 0.1-μF, power-supply bypass capacitor.

5.3 R1_n, R5_n (Rshunt)

Rshunt is unpopulated, but allows the user to solder down a surface-mount shunt resistor between the In+ and In– pads sensed by IN+ and IN– input pins. If used, make sure Rshunt has proper power dissipation for the selected current load and below 5 A. The chosen resistor must have a 2512 footprint.

5.4 U1_n (INA2290)

U1_An is the location for the INA2290An test device.

Consider these factors when selecting the appropriate device gain:

- The differential input voltage is either applied across the inputs or developed based on the load current that flows through the shunt resistor.
- Make sure that the output voltage does not exceed the supply voltage. This limiting factor requires attention to device selection.
- The selected device must allow the output voltage to remain within the acceptable range after the developed input voltage is amplified by the respective device gain. The output voltage must remain within the device-specified swing limitations for response in the linear range.
- An output below the minimum allowable output requires a device with a higher gain. Likewise, an output above the maximum allowable output requires a device with a lower gain.

6 Schematic, PCB Layout, and Bill of Materials

Note

Board layouts are not to scale. These figures are intended to show how the board is laid out. They are not intended to be used for INA2290EVM PCB manufacturing.

6.1 Schematics

Figure 6-1 through Figure 6-5 show the schematics for the A pinout of the INA2290EVM PCB for all gain options.

Input side capable up to 120V; Input Current <5A when using onboard Rx1 as shunt resistor

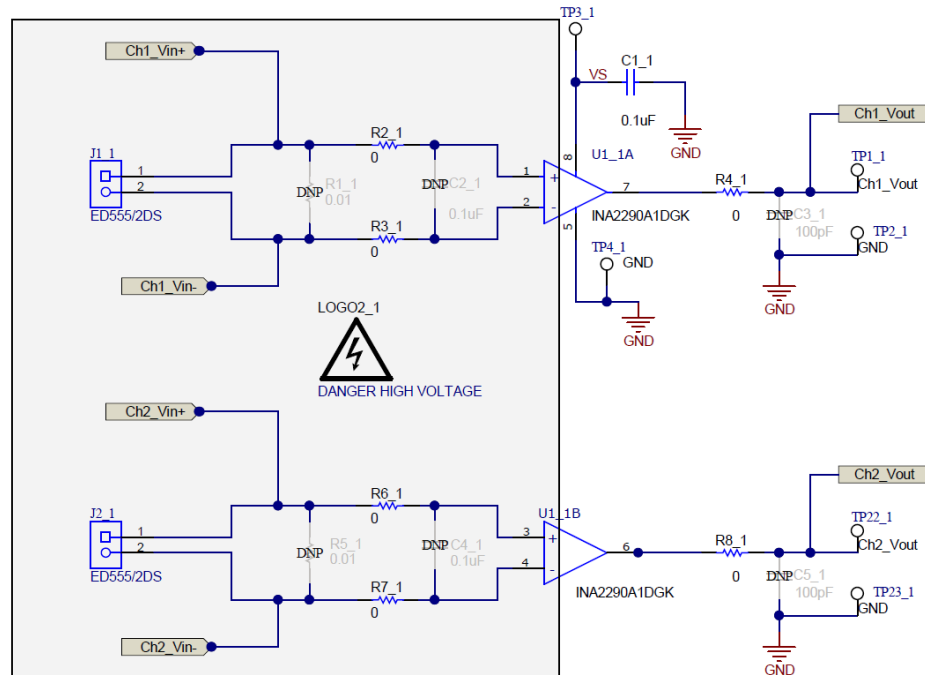

Figure 6-1. INA2290EVM Schematic: Gain A1 Panel

Input side capable up to 120V; Input Current <5A when using onboard Rx1 as shunt resistor

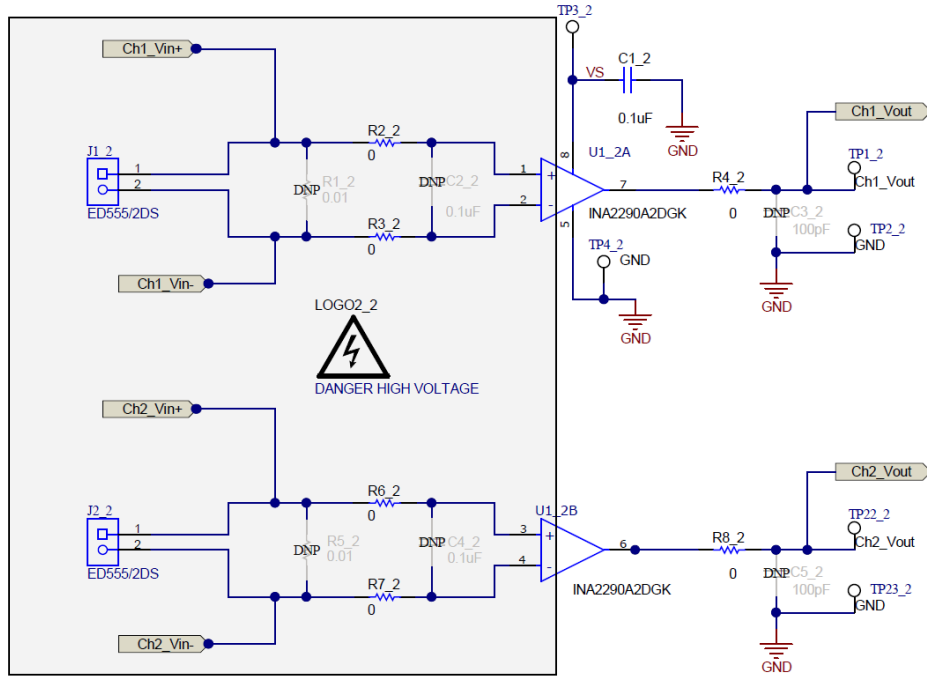

Figure 6-2. INA2290EVM Schematic: Gain A2 Panel

Input side capable up to 120V; Input Current <5A when using onboard Rx1 as shunt resistor

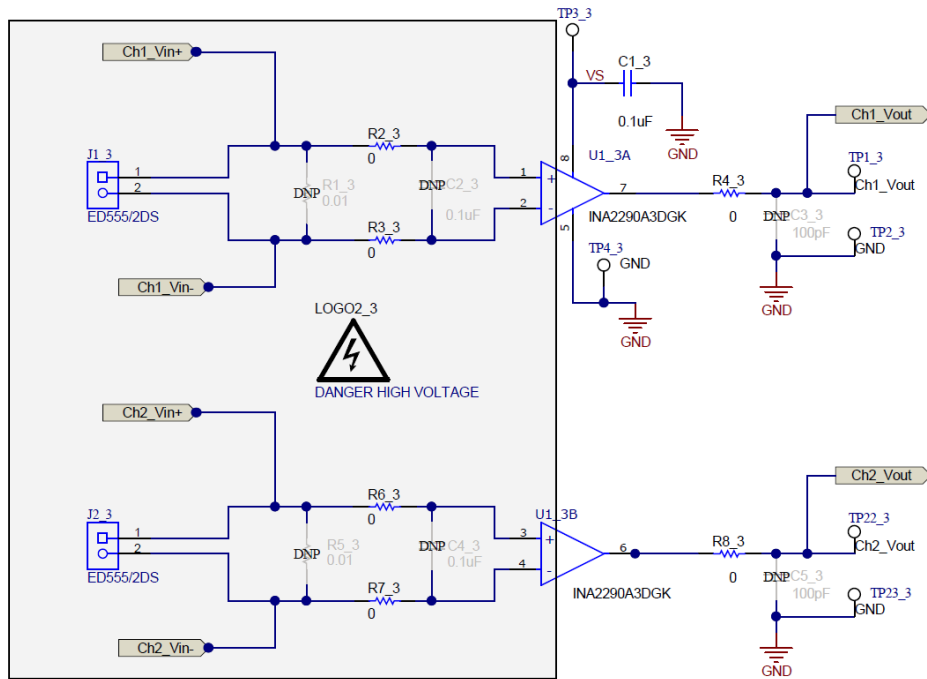

Figure 6-3. INA2290EVM Schematic: Gain A3 Panel

Input side capable up to 120V; Input Current <5A when using onboard Rx1 as shunt resistor

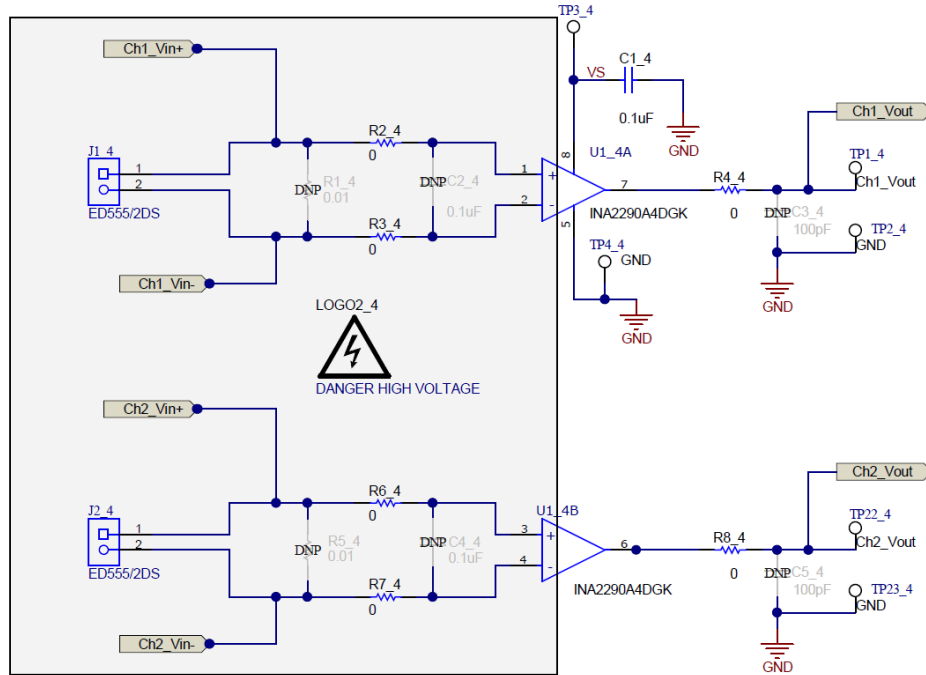

Figure 6-4. INA2290EVM Schematic: Gain A4 Panel

Input side capable up to 120V; Input Current <5A when using onboard Rx1 as shunt resistor

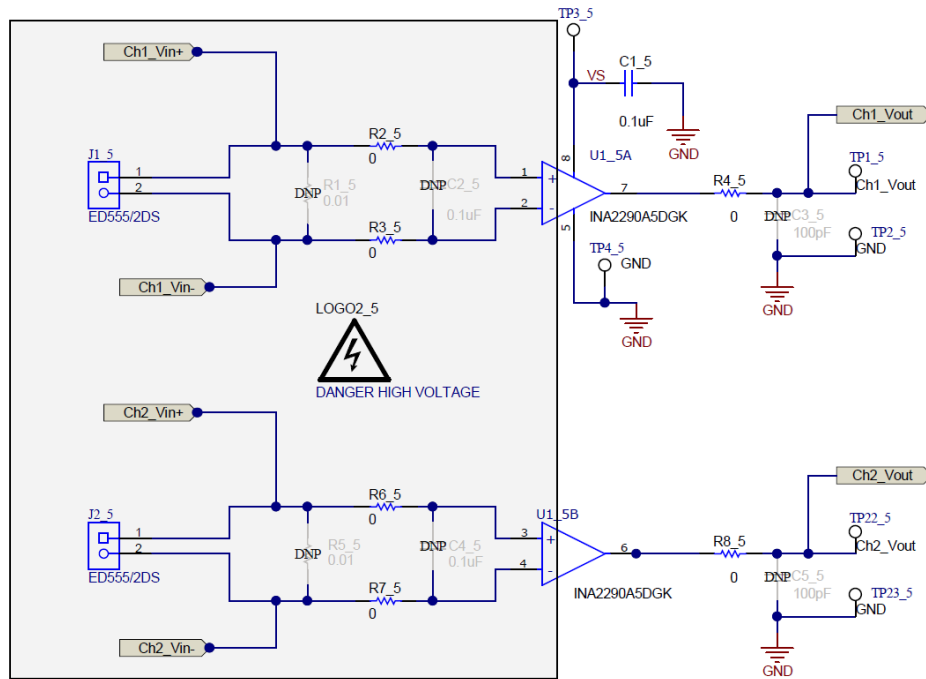

Figure 6-5. INA2290EVM Schematic: Gain A5 Panel

6.2 PCB Layout

Figure 6-6 through Figure 6-12 show the PCB layout for the INA2290EVM.

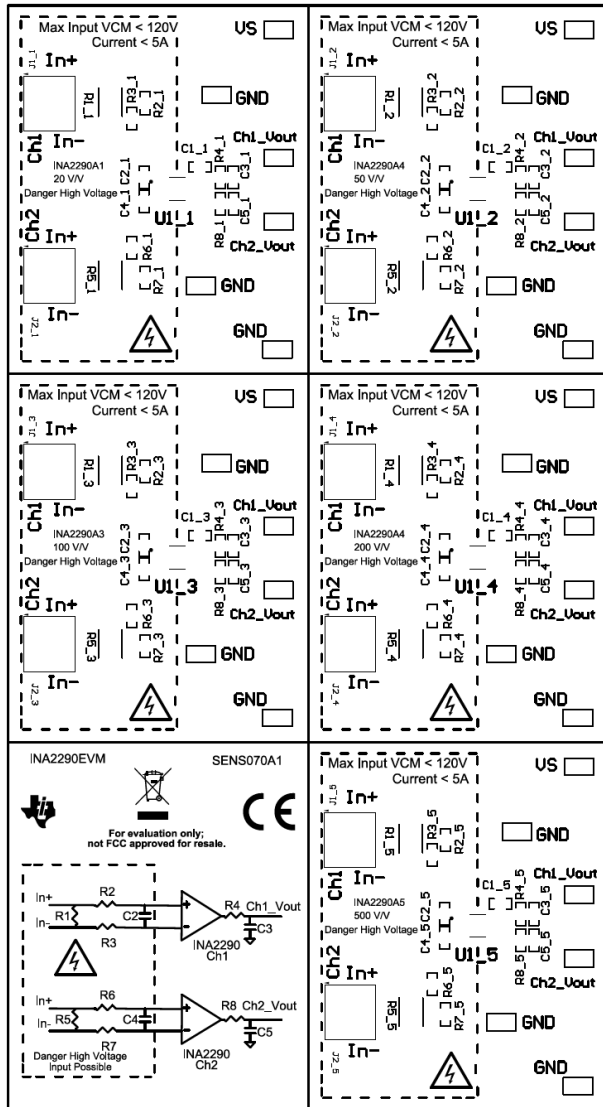

Figure 6-6. INA2290EVM Top Overlay

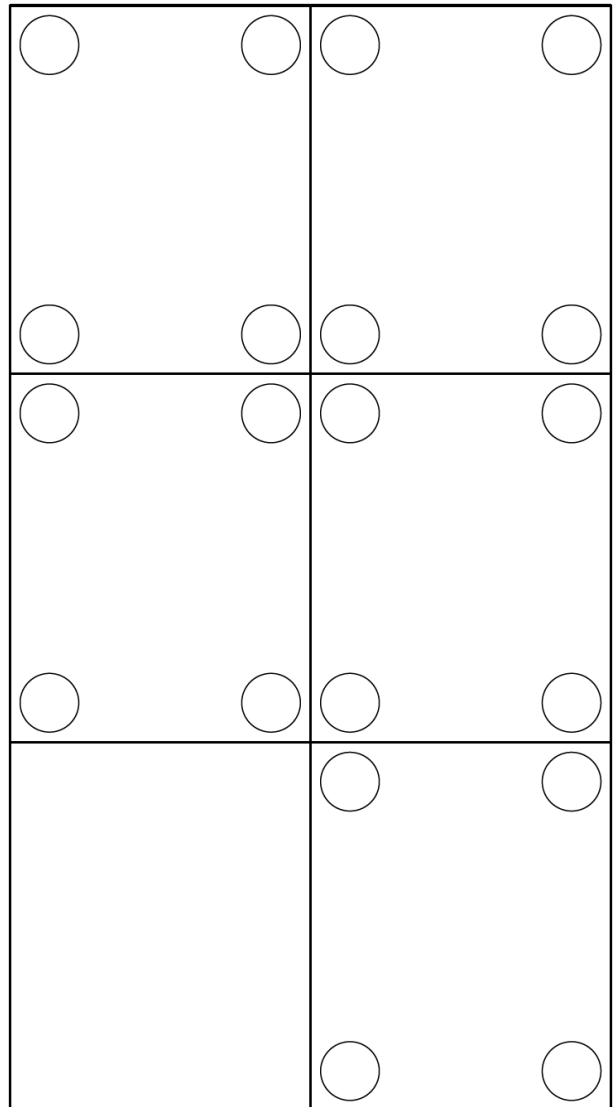

Figure 6-7. INA2290EVM Bottom Overlay

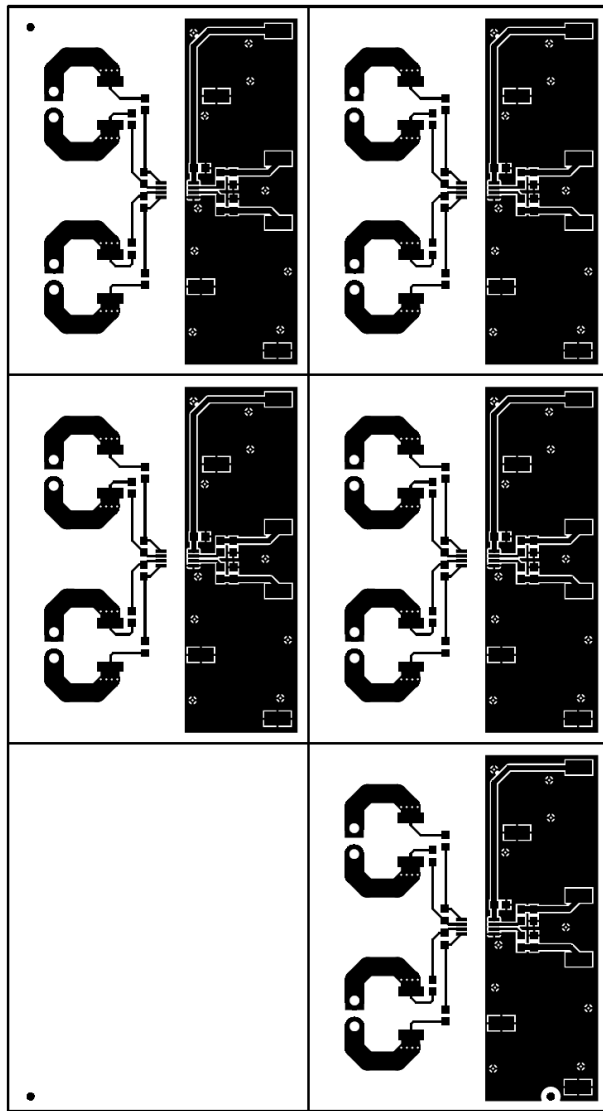

Figure 6-8. INA2290EVM Top Layer

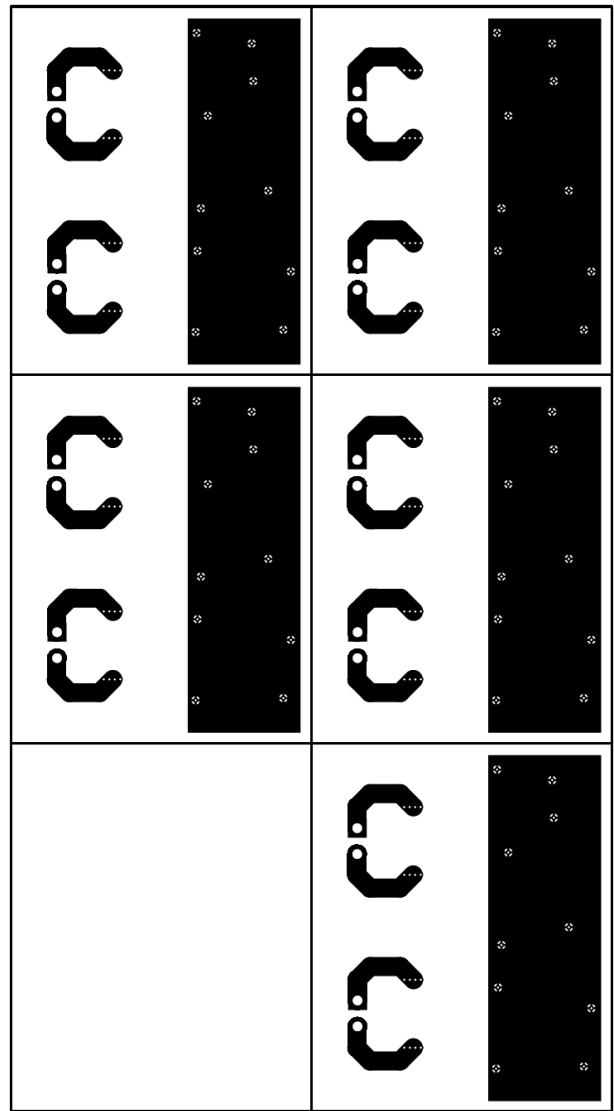

Figure 6-9. INA2290EVM Bottom Layer

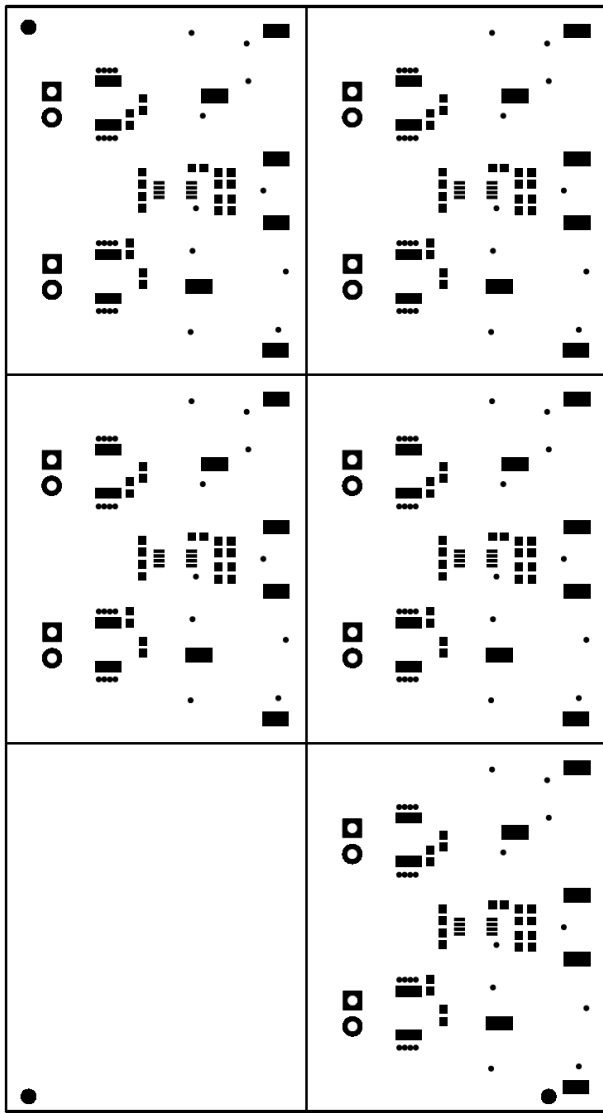

Figure 6-10. INA2290EVM Top Solder

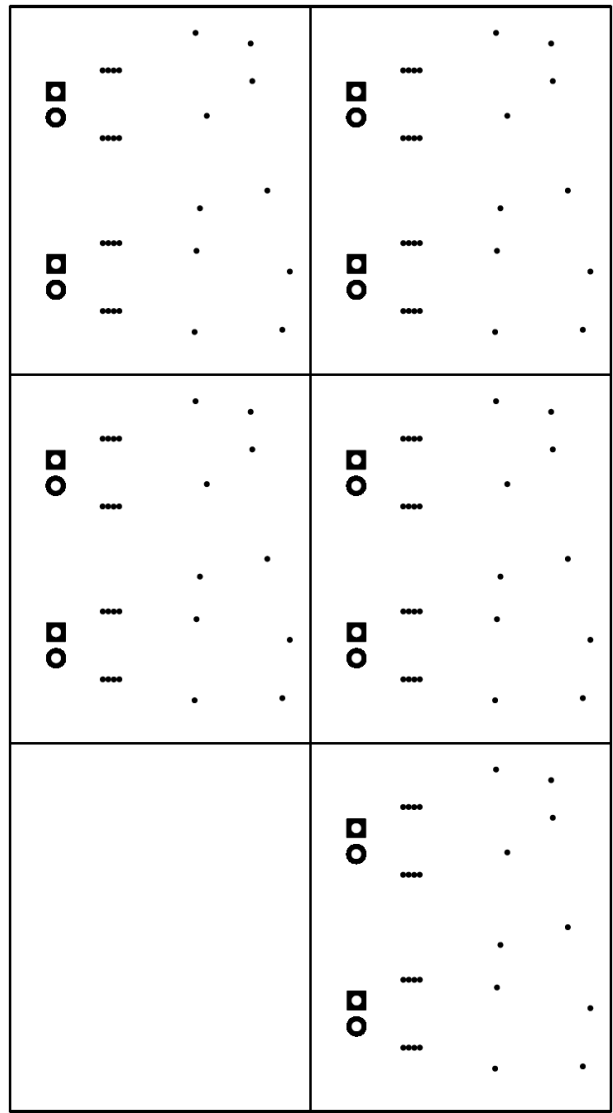
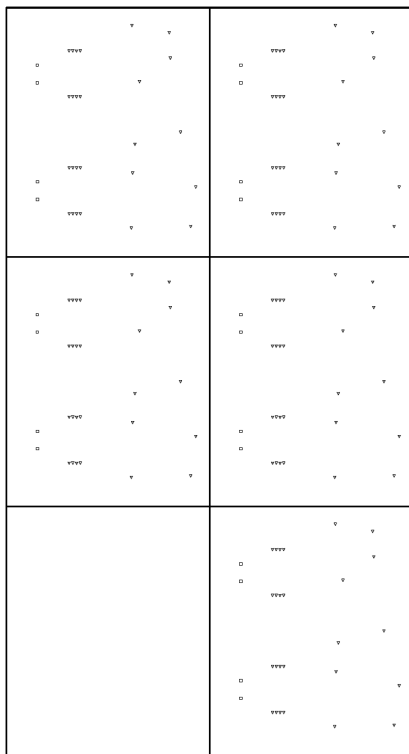

Figure 6-11. INA2290EVM Bottom Solder



Symbol	Quantity	Finished Hole Size	Plated	Hole Type	Drill Layer Pair	Hole Tolerance
V	130	10.00mil (0.254mm)	PTH	Round	Top Layer - Bottom Layer	
□	20	50.00mil (1.270mm)	PTH	Round	Top Layer - Bottom Layer	
	150 Total					

Figure 6-12. INA2290EVM Drill Drawing

6.3 Bill of Materials

Table 6-1 provides the parts list for the INA2290EVM.

Table 6-1. Bill of Materials

DESIGNATOR	QTY	VALUE	DESCRIPTION	PACKAGE REFERENCE	PART NUMBER	MANUFACTURER
C1_1, C1_2, C1_3, C1_4, C1_5	5	0.1uF	CAP, CERM, 0.1 uF, 25 V, +/- 10%, X7R, AEC-Q200 Grade 1, 0603	0603	CGA3E2X7R1E104K080AA	TDK
H1_1, H1_2, H1_3, H1_4, H1_5, H2_1, H2_2, H2_3, H2_4, H2_5, H3_1, H3_2, H3_3, H3_4, H3_5, H4_1, H4_2, H4_3, H4_4, H4_5	20		Bumpon, Cylindrical, 0.312 X 0.200, Black	Black Bumpon	SJ61A1	3M
J1_1, J1_2, J1_3, J1_4, J1_5, J2_1, J2_2, J2_3, J2_4, J2_5	10		Terminal Block, 3.5mm Pitch, 2x1, TH	7.0x8.2x6.5mm	ED555/2DS	On-Shore Technology
R2_1, R2_2, R2_3, R2_4, R2_5, R3_1, R3_2, R3_3, R3_4, R3_5, R4_1, R4_2, R4_3, R4_4, R4_5, R6_1, R6_2, R6_3, R6_4, R6_5, R7_1, R7_2, R7_3, R7_4, R7_5, R8_1, R8_2, R8_3, R8_4, R8_5	30	0	RES, 0, 5%, 0.125 W, 0603	0603	MCT06030Z0000ZP500	Vishay/Beyschlag
TP1_1, TP1_2, TP1_3, TP1_4, TP1_5, TP2_1, TP2_2, TP2_3, TP2_4, TP2_5, TP3_1, TP3_2, TP3_3, TP3_4, TP3_5, TP4_1, TP4_2, TP4_3, TP4_4, TP4_5, TP22_1, TP22_2, TP22_3, TP22_4, TP22_5, TP23_1, TP23_2, TP23_3, TP23_4, TP23_5	30		Test Point, Miniature, SMT	Testpoint_Keystone_Minature	5015	Keystone
U1_1	1		120V, 2-CH, High Bandwidth, High Side, Unidirectional Current Sense Amplifier	MSOP8	INA2290A1DGK	Texas Instruments
U1_2	1		120V, 2-CH, High Bandwidth, High Side, Unidirectional Current Sense Amplifier	MSOP8	INA2290A2DGK	Texas Instruments
U1_3	1		120V, 2-CH, High Bandwidth, High Side, Unidirectional Current Sense Amplifier	MSOP8	INA2290A3DGK	Texas Instruments
U1_4	1		120V, 2-CH, High Bandwidth, High Side, Unidirectional Current Sense Amplifier	MSOP8	INA2290A4DGK	Texas Instruments
U1_5	1		120V, 2-CH, High Bandwidth, High Side, Unidirectional Current Sense Amplifier	MSOP8	INA2290A5DGK	Texas Instruments
C2_1, C2_2, C2_3, C2_4, C2_5, C4_1, C4_2, C4_3, C4_4, C4_5	0	0.1uF	CAP, CERM, 0.1 uF, 25 V, +/- 10%, X7R, AEC-Q200 Grade 1, 0603	0603	CGA3E2X7R1E104K080AA	TDK
C3_1, C3_2, C3_3, C3_4, C3_5, C5_1, C5_2, C5_3, C5_4, C5_5	0	100pF	CAP, CERM, 100 pF, 50 V, +/- 10%, X7R, 0603	0603	CL10B101KB8NNNC	Samsung Electro-Mechanics
FID1, FID2, FID3	0		Fiducial mark. There is nothing to buy or mount.	N/A	N/A	N/A

Table 6-1. Bill of Materials (continued)

DESIGNATOR	QTY	VALUE	DESCRIPTION	PACKAGE REFERENCE	PART NUMBER	MANUFACTURER
R1_1, R1_2, R1_3, R1_4, R1_5, R5_1, R5_2, R5_3, R5_4, R5_5	0	0.01	RES, 0.01, 1%, 3 W, 2512	2512	CRA2512-FZ-R010ELF	Bourns

7 Revision History

NOTE: Page numbers for previous revisions may differ from page numbers in the current version.

Changes from Revision * (September 2020) to Revision A (December 2020)	Page
• Updated all images associated with Schematic and PCB for latest released hardware.....	8

IMPORTANT NOTICE AND DISCLAIMER

TI PROVIDES TECHNICAL AND RELIABILITY DATA (INCLUDING DATA SHEETS), DESIGN RESOURCES (INCLUDING REFERENCE DESIGNS), APPLICATION OR OTHER DESIGN ADVICE, WEB TOOLS, SAFETY INFORMATION, AND OTHER RESOURCES "AS IS" AND WITH ALL FAULTS, AND DISCLAIMS ALL WARRANTIES, EXPRESS AND IMPLIED, INCLUDING WITHOUT LIMITATION ANY IMPLIED WARRANTIES OF MERCHANTABILITY, FITNESS FOR A PARTICULAR PURPOSE OR NON-INFRINGEMENT OF THIRD PARTY INTELLECTUAL PROPERTY RIGHTS.

These resources are intended for skilled developers designing with TI products. You are solely responsible for (1) selecting the appropriate TI products for your application, (2) designing, validating and testing your application, and (3) ensuring your application meets applicable standards, and any other safety, security, regulatory or other requirements.

These resources are subject to change without notice. TI grants you permission to use these resources only for development of an application that uses the TI products described in the resource. Other reproduction and display of these resources is prohibited. No license is granted to any other TI intellectual property right or to any third party intellectual property right. TI disclaims responsibility for, and you will fully indemnify TI and its representatives against, any claims, damages, costs, losses, and liabilities arising out of your use of these resources.

TI's products are provided subject to [TI's Terms of Sale](#) or other applicable terms available either on ti.com or provided in conjunction with such TI products. TI's provision of these resources does not expand or otherwise alter TI's applicable warranties or warranty disclaimers for TI products.

TI objects to and rejects any additional or different terms you may have proposed.

Mailing Address: Texas Instruments, Post Office Box 655303, Dallas, Texas 75265
Copyright © 2022, Texas Instruments Incorporated