

Design Guide: TIDA-050057

PC アプリケーションにおける Alder Lake および Raptor Lake の VCCIN_AUX レール用電源ソリューションのリファレンス・デザイン



概要

この電源リファレンス・デザインは、Intel®Alder Lake および Raptor Lake プラットフォームの VCCIN_AUX レールをサポートしています。TPS51215A コントローラをオペアンプと組み合わせて使用すると、VID 制御、負荷ライン (LL)、電流モニタ (IMON) などの制御機能をサポートできます。このリファレンス・デザインでは、テスト・ツール・インターポーザーの位置を確保しており、評価が容易です。

リソース

TIDA-050057	デザイン・フォルダ
TPS51215A	プロダクト・フォルダ
TLV9051	プロダクト・フォルダ
CSD87355Q5D	プロダクト・フォルダ

特長

- 差動電圧帰還
- 2 ビット VID により、0.5V~2.0V および 0V VOUT からの柔軟な出力電圧をサポート
- ソフトスタート時間と出力電圧の遷移時間をプログラム可能
- 2mΩ の負荷ライン (LL) による負荷過渡の強化

アプリケーション

- 標準的ノート PC
- デスクトップ PC 向けマザーボード
- 産業用ファクトリ・オートメーション / 制御

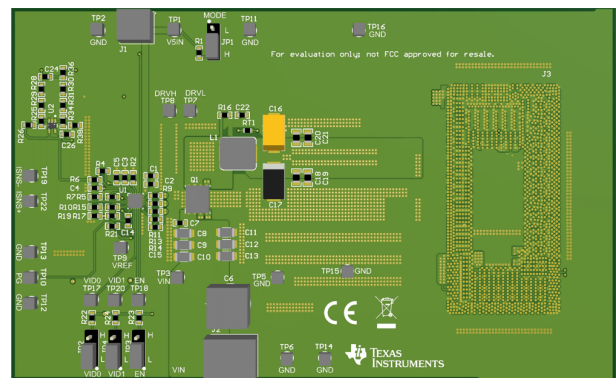
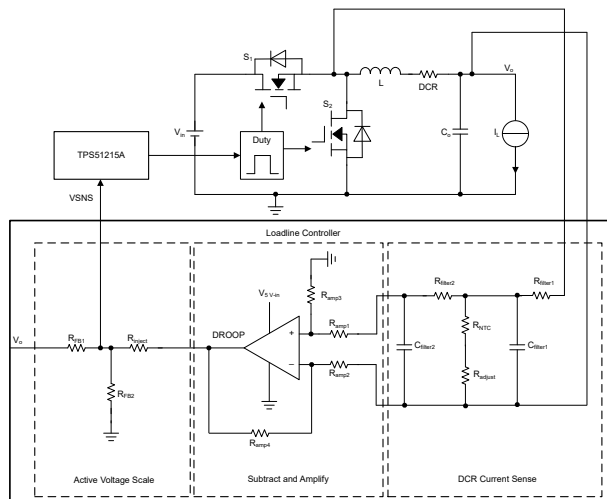
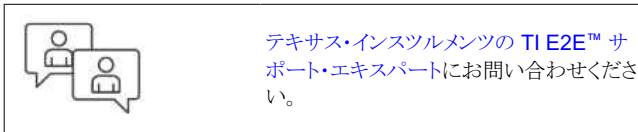

1 System Description

The TIDA-050057 provides a power solution design for VCCIN_AUX rail in Intel® Alder Lake and Raptor Lake platform. TPS51215A is a synchronous buck controller with VID control bit. Combined with an operational amplifier, 2 mΩ load line is implemented. The position for test tool interposer is reserved in the reference design to help fast evaluation.

2 System Overview

2.1 Block Diagram

The basic block diagram of TPS51215A power solution with load line and IMON features is shown as [Figure 2-1](#).

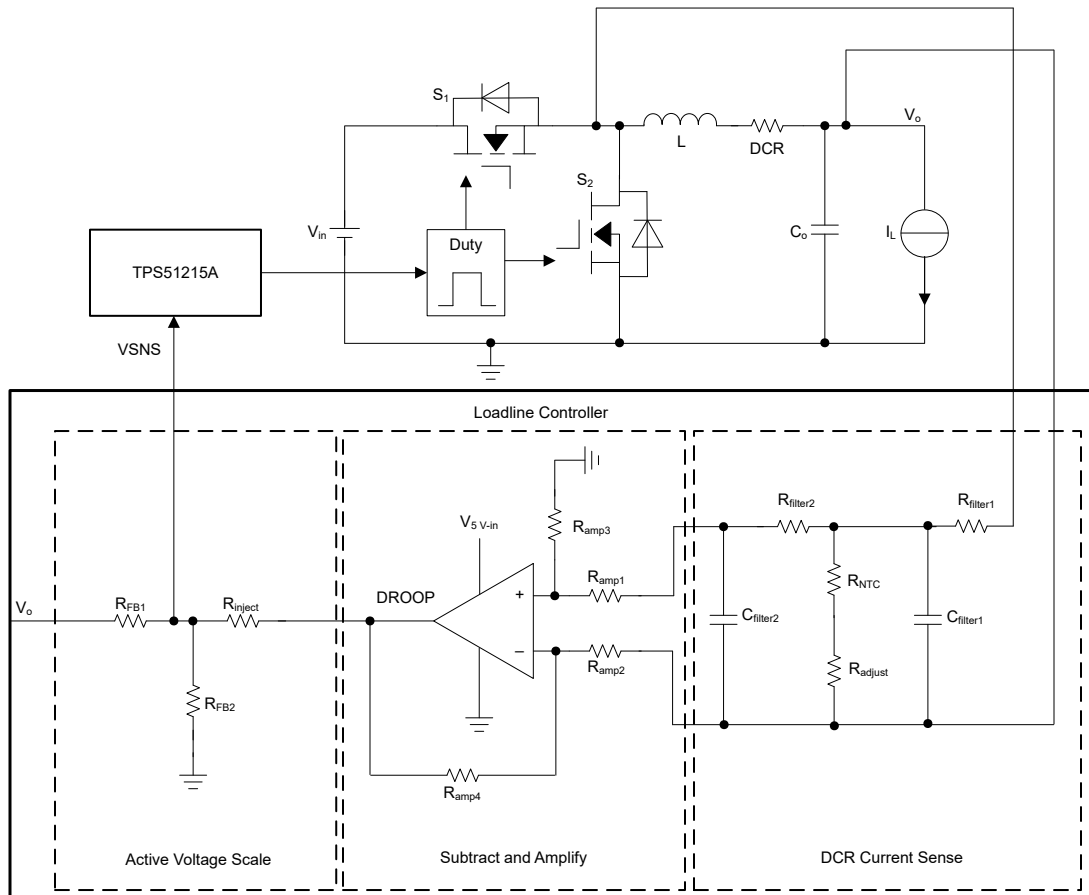

Figure 2-1. TPS51215A Power Solution with Load Line Feature Block Diagram

2.2 Design Considerations

There are three functional blocks for load line controller and IMON implementation:

2.2.1 DCR current sense

Load line control will get the output voltage decreased with the increasing output current linearly, while the IMON feature needs to have a voltage output proportional to output current. The output current needs to be sensed for both of the two features. An inductor DCR current sense is implemented in the proposed method. Compared with current sense with sensing resistor, additional cost can be saved. Two stage RC filter is used to filter the inductor current ripple and get the DC output current information.

2.2.2 Subtract and Amplify

Inductors with small DCR are always used for TPS51215A due to large current rating of VCCIN_AUX rail. So the sensed DCR voltage amplitude is small and the amplification is needed to implement. At the same time, the sensed voltage is a signal referenced to Vout and floating to ground. To get the sensed current signal used for

active voltage scaling, it needs to be converted to a signal referenced to ground. Those two functions are achieved with an operational amplifier.

2.2.3 Active Voltage Scale

Active voltage scaling is used to create the output voltage load line based on sensed current information. By injecting the sensed current signal into voltage sense pin through a resistor network, the output voltage could be regulated.

2.2.4 IMON Output

IMON output is needed by IMVP multiphase VR controller. IMVP controller has related pins for the input and they should be connected with the IMON output from VCCIN_AUX solution.

Currently, there are two major types of IMON output signal, which is determined by the used IMVP VR controller:

- The first type of IMON output is inductor DCR current sensing signal. For this type of IMON, the IMVP VR controller has two pins for differential IMON input. The solution proposed in this reference design is compatible with this type of IMVP VR controller. The differential voltage signals on C_{filter1} in 2-1 are the IMON output and could be directly connected with VR controller.
- The second type of IMON output is a single-ended voltage proportional to inductor average current and referenced to ground. The solution proposed in this reference design is not compatible with this type of IMVP controller.

The schematic design is shown as 2-2.

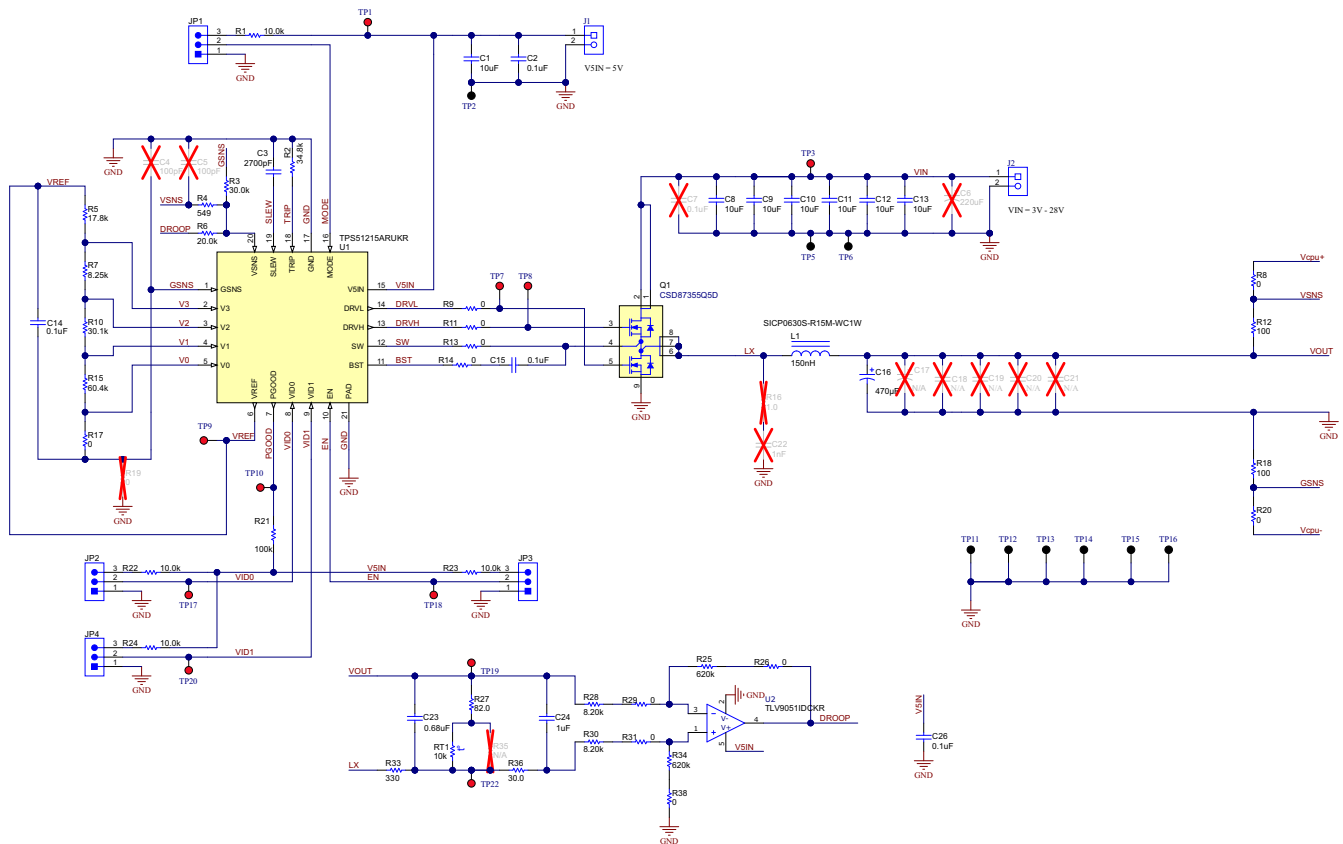

2-2. TPS51215A Power Solution with Load Line Feature Schematic

2-2 is the major page of schematic in this reference design, which only includes the circuits around voltage regulator. The symbol for test tool interposer and the output capacitors placed at loading side (interposer side) are not shown here.

The complete schematics of the reference design are at TIDA-050057.

The principle for implementation will be introduced in セクション 2.4.

2.3 Highlighted Products

TPS51215A is a single-phase, D-CAP2™ synchronous buck controller with a 2-bit VID input supporting 0 V and three other independent externally programmable output voltage levels, where full external programmability of the voltage level, step setting, and voltage-change slew rate is desired.

The TPS51215A supports all POS/SPCAP and/or all ceramic MLCC output capacitor options in applications where remote sense is a requirement. Tight DC load regulation is achieved through external programmable integrator capacitor. The TPS51215A provides full protection suite, including OVP, OCL, 5-V UVLO, and thermal shutdown. It supports the conversion voltage up to 28 V, and output voltages adjustable from 0.5 V to 2 V.

2.4 System Design Theory

2.4.1 DCR Current Sense



图 2-3. DCR Current Sense Block

A voltage proportional to inductor DC current (V_{ISNS}) can be got with DCR current sense block as shown in 图 2-3. First stage filter with $R_{filter1}$ and $C_{filter1}$ is used to get inductor current information from SW pulse voltage. Second stage filter is used to get DC value from sensed inductor current and filter the ripple. R_{NTC} is a negative thermal coefficient resistor, which is used to compensate the DCR variation with temperature. R_{adjust} is used for matching the thermal coefficient of R_{NTC} and DCR. It's targeted to let the V_{ISNS} not changed with temperature variation.

Why do we need a second stage RC filter to extract DC current information?

- Low frequency and middle frequency inductor current information are needed for feedback to reflect output current DC value and dynamic changing.
- High frequency response needs to be limited, since the inductor current ripple needs to be filtered.
- Two stage filter can bring -40 dB/dec gain slope at high frequency. 图 2-4 shows how the two stage filter can have lower gain at high frequency while maintaining larger gain in middle frequency range.

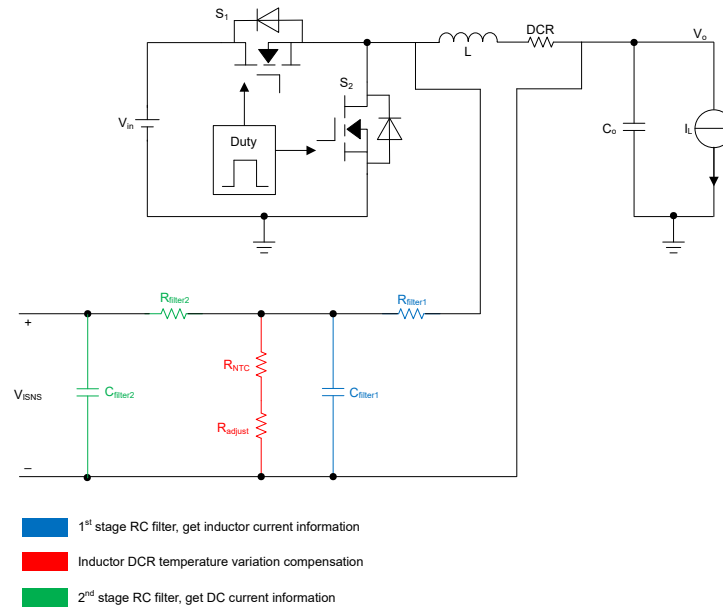

图 2-4. Comparison of Frequency Response with One-Stage RC Filter and Two-Stage RC Filter

2.4.2 Subtract and Amplify

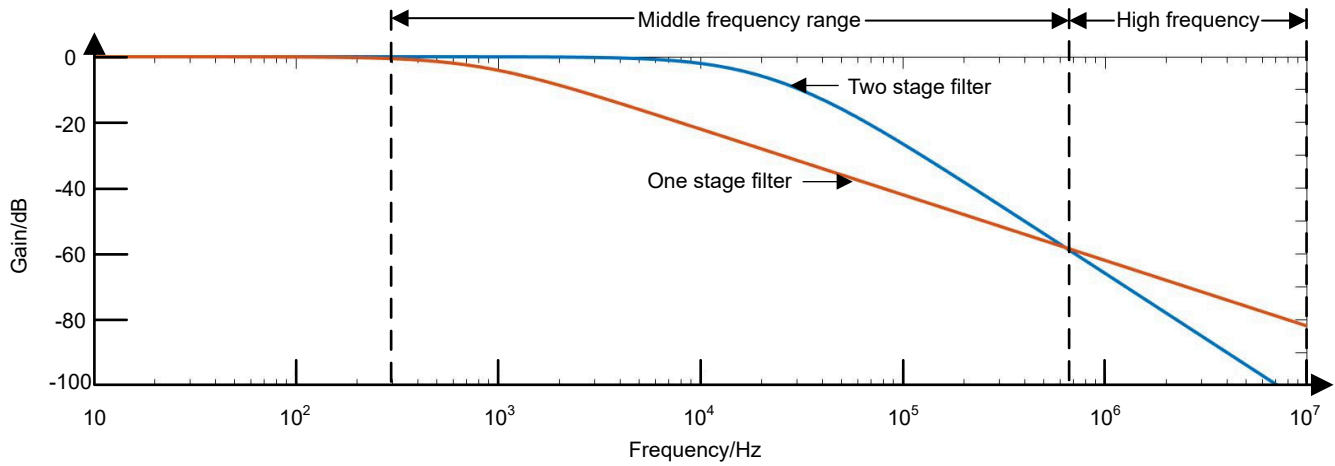

图 2-5. Operational Amplifier for Subtraction

Operational amplifier shown in 图 2-5 is used to convert the differential V_{ISNS} to single-ended DROOP signal. The resistor network is also set to amplify the voltage amplitude.

Normally, we just set $R_{amp1}=R_{amp2}$, $R_{amp3}=R_{amp4}$. Amplification ratio is equal to R_{amp3}/R_{amp1} .

2.4.3 Active Voltage Scale

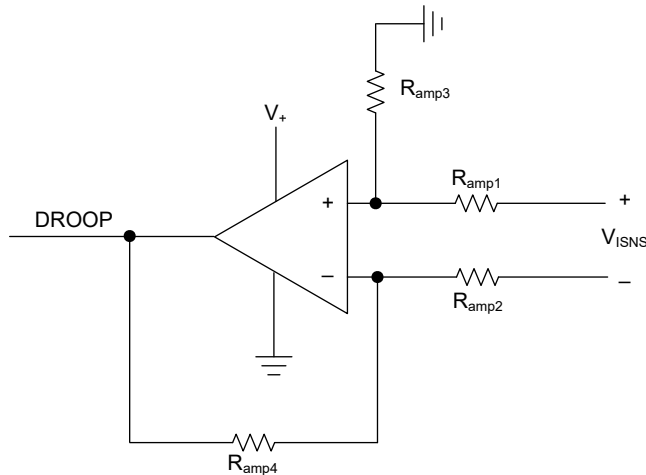

图 2-6. Resistor Network for Voltage Scaling

The voltage scaling block to achieve output voltage load line is shown as [Figure 2-6](#).

Based on superposition theorem:

$$V_{SNS} = V_O \times \frac{R_{FB2} \parallel R_{inject}}{R_{FB1} + R_{FB2} \parallel R_{inject}} + DROOP \times \frac{R_{FB1} \parallel R_{FB2}}{R_{inject} + R_{FB1} \parallel R_{FB2}} \quad (1)$$

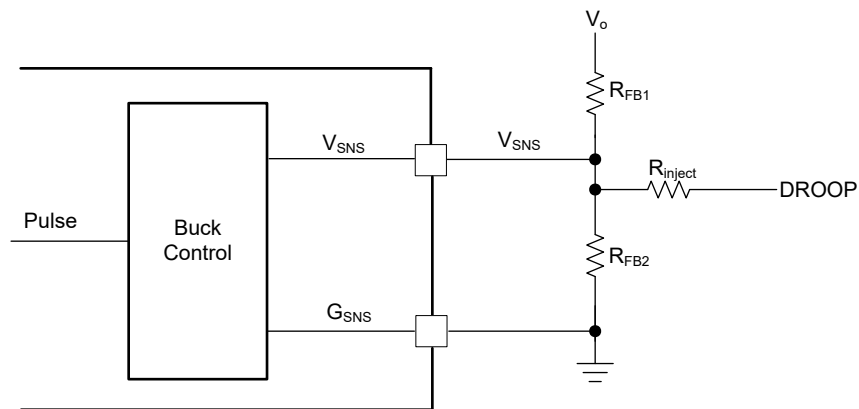
Since $V_{SNS} = V_{ref}$ and DC value of V_{ref} is fixed in regulation, when load current becomes larger, DROOP will increase and V_O will decrease.

The DROOP is proportional to output current, thus the decrease of V_O is also proportional to output current, which corresponds to the load line needed.

2.4.4 IMON Output

As introduced in [Section 2.2.4](#), IMON output signals with this reference design are inductor DCR current sensing signals. A pair of differential IMON output wires ISNS+ (TP22) and ISNS- (TP19) in schematic [Figure 2-2](#) needs to be connected with the corresponding pins of IMVP multi-phase VR controller.

3 Hardware, Software, Testing Requirements, and Test Results

3.1 Hardware Requirements

For testing purposes, this reference design requires the following equipment:

- A power supply that is capable of supplying at least 7-A of load and up to 24-V.
- A power supply that is capable of supplying 5-V.
- Current and voltage multimeters to measure the currents and voltages during the related tests.
- Oscilloscope to capture voltages and a current.
- The TIDA-050057 board is a printed circuit board (PCB) with all the devices in this design.
- Resistive load or electronic load that is capable at least 32-A.

3.2 Test Setup

3-1 shows the set up used to test the TIDA-050057. Test tool refers to Intel® VR Test Tool. The following start-up procedure is shown below.

1. Jump the JP2 and JP4 according to required VID output voltage or connect external drive signals to the TP17 and TP20.
2. Apply proper DC voltage to J1 and J2. Apply J2 with external power source first and then apply J1 5 V with another power source.
3. Jump the JP3 to high to enable the device or connect external drive signals to TP18.
4. Check the output.



图 3-1. Test Setup

3.3 Test Results

3.3.1 Start-up

Figure 3-2 shows the start-up behavior.

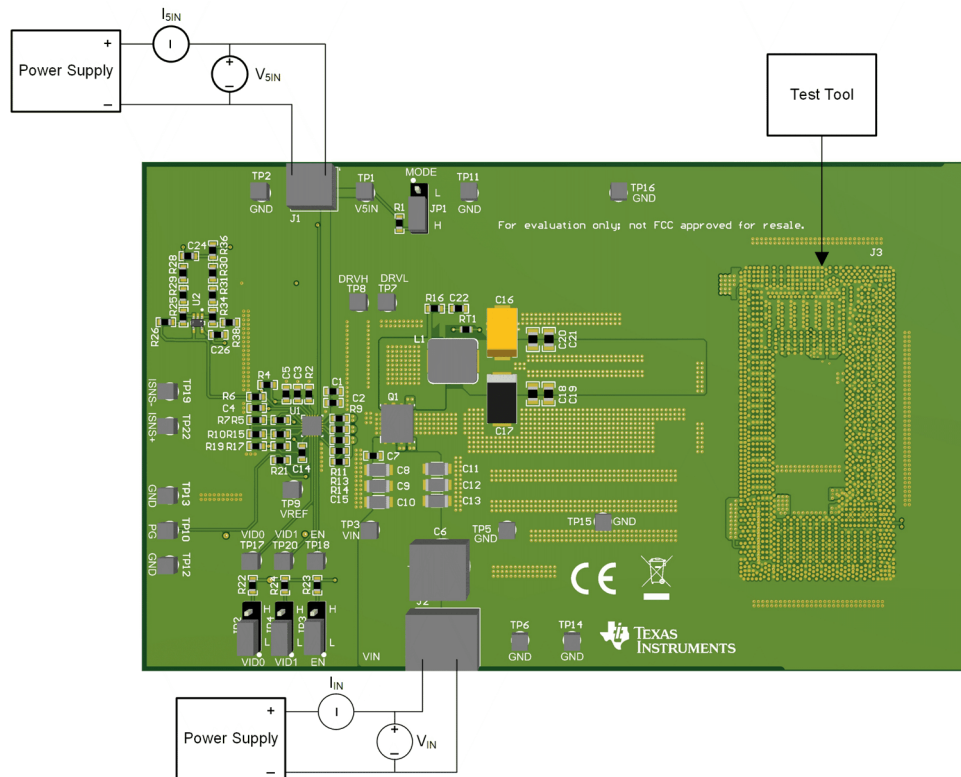
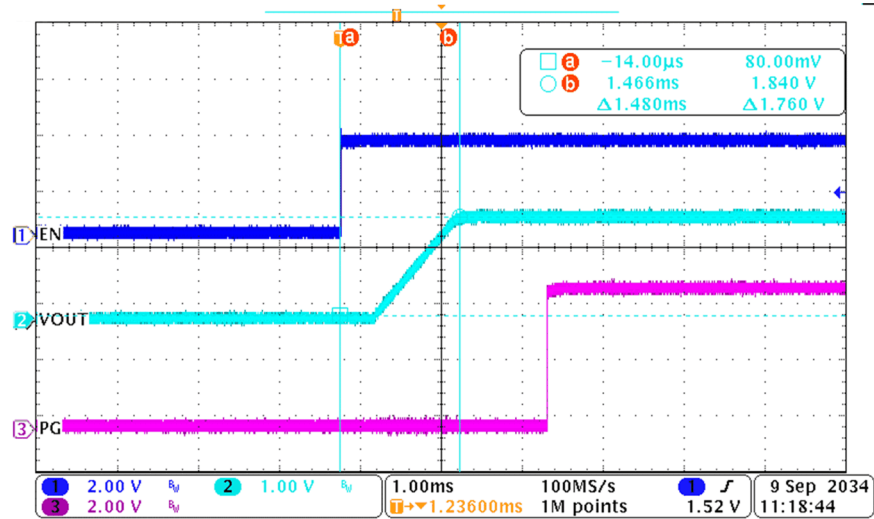

Figure 3-2. Start-up Behavior

3.3.2 VID Change

Figure 3-3 shows the VID change behavior. VID changes from 00 to 11 and Vout changes from 0 V to 1.8 V.

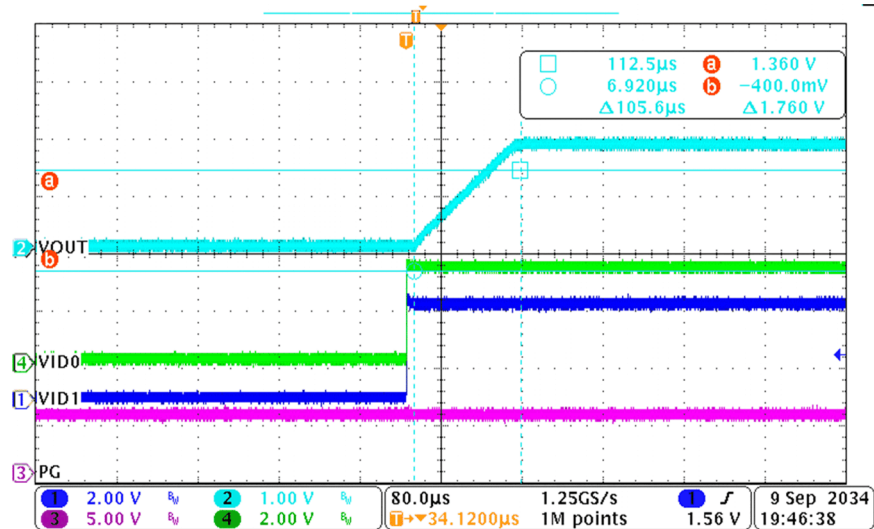

Figure 3-3. VID Change Behavior

3.3.3 Load Transient

Figure 3-4 shows the transient response. Output current varies between 9.6 A-32 A with 250ns rise or fall time. Output voltage varies in the range of 1.69 V-1.85 V.

In the waveform, total output current is the combined measured current of channel 1 and channel 4.

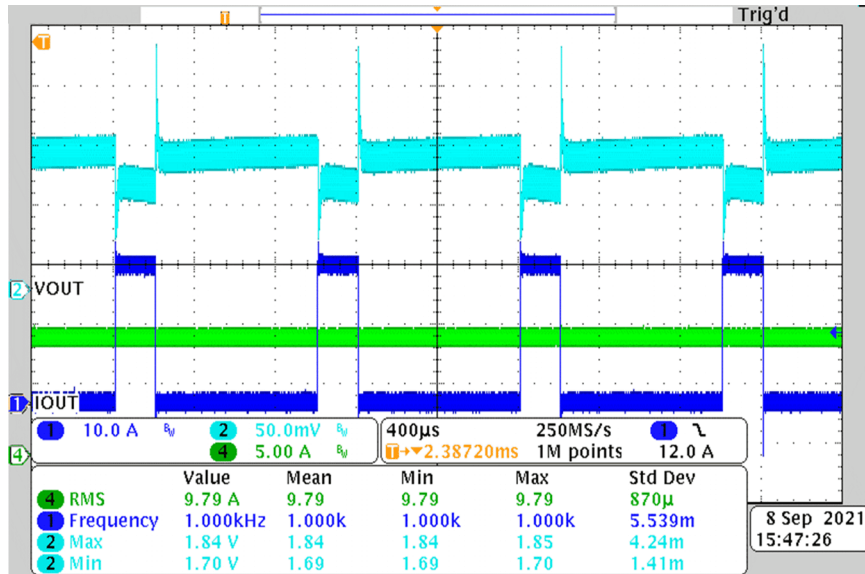

Figure 3-4. Load Transient Behavior

3.3.4 Load-Line Test

Figure 3-5 shows the load line test results.

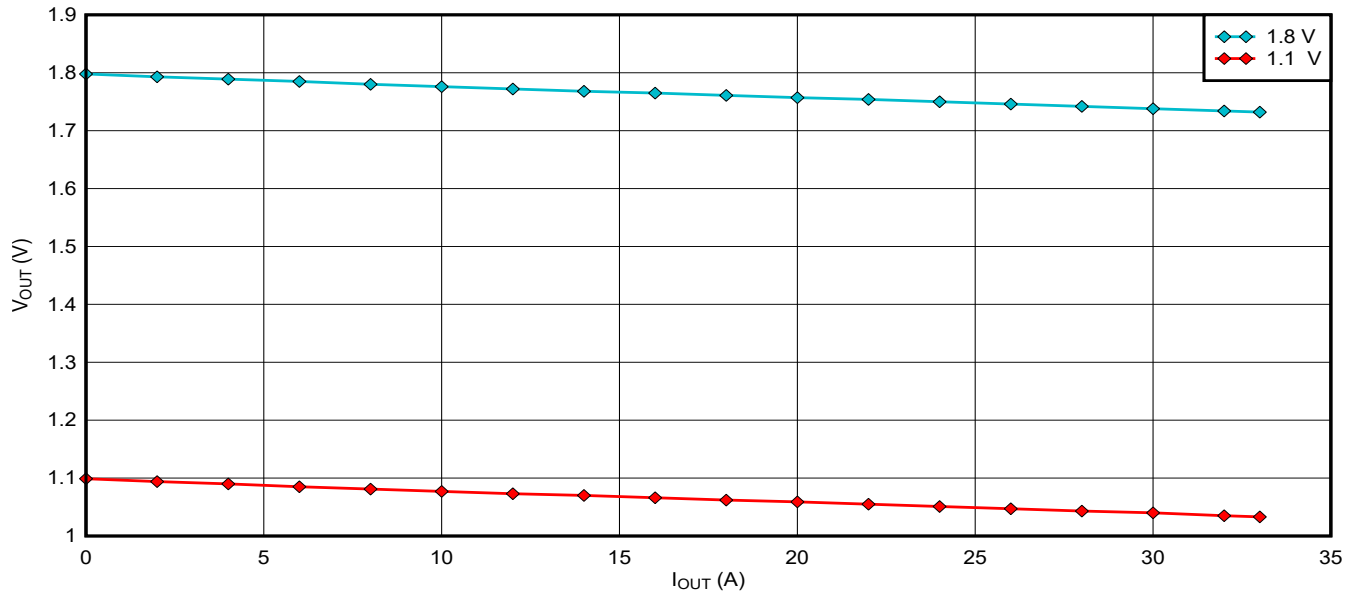

Figure 3-5. Load-Line Test Results

4 Design and Documentation Support

4.1 Design Files

4.1.1 Schematics

To download the schematics, see the design files at [TIDA-050057](#).

4.1.2 BOM

To download the bill of materials (BOM), see the design files at [TIDA-050057](#).

4.1.3 PCB Layout Recommendations

To download the layer plots, see the design files at [TIDA-050057](#).

4.1.4 Altium Project

To download the Altium Designer® project files, see the design files at [TIDA-050057](#).

4.1.5 Gerber Files

To download the Gerber files, see the design files at [TIDA-050057](#).

4.1.6 Assembly Drawings

To download the assembly drawings, see the design files at [TIDA-050057](#).

4.2 Documentation Support

1. Texas Instruments, [TPS51215A Single Phase, D-CAP2™ Controller with 2-Bit VID Control and Low Power Mode](#) data sheet.
2. Texas Instruments, [TLV9051 / TLV9052 / TLV9054 5-MHz, 15-V/μs High Slew-Rate, RRIO Op Amp](#) data sheet.
3. Texas Instruments, [CSD87355Q5D Synchronous Buck NexFET™ Power Block](#) data sheet.

4.3 サポート・リソース

TI E2E™ サポート・フォーラムは、エンジニアが検証済みの回答と設計に関するヒントをエキスパートから迅速かつ直接得ることができる場所です。既存の回答を検索したり、独自の質問をしたりすることで、設計に必要な支援を迅速に得ることができます。

リンクされているコンテンツは、該当する貢献者により、現状のまま提供されるものです。これらは TI の仕様を構成するものではなく、必ずしも TI の見解を反映したものではありません。TI の [使用条件](#) を参照してください。

4.4 Trademarks

TI E2E™ and D-CAP2™ are trademarks of Texas Instruments.

Intel® is a registered trademark of Intel.

すべての商標は、それぞれの所有者に帰属します。

5 About the Authors

Andrew Xiong is a systems and applications engineer at Texas Instruments responsible for defining new products based on business opportunities and providing application support to assist customers with technical challenges.

Yuchang Zhang joined Texas Instruments as an experienced applications engineer in 2016 and currently works in the Buck DC/DC Switching Regulators group as a systems and applications engineer. He focuses on customer support in the personal electronics market.

Xueliang Zhang is an applications engineer at Texas Instruments and currently works on the application support team to assist customers with technical challenges.

重要なお知らせと免責事項

TI は、技術データと信頼性データ(データシートを含みます)、設計リソース(リファレンス・デザインを含みます)、アプリケーションや設計に関する各種アドバイス、Web ツール、安全性情報、その他のリソースを、欠陥が存在する可能性のある「現状のまま」提供しており、商品性および特定目的に対する適合性の黙示保証、第三者の知的財産権の非侵害保証を含むいかなる保証も、明示的または黙示的にかかわらず拒否します。

これらのリソースは、TI 製品を使用する設計の経験を積んだ開発者への提供を意図したものです。(1) お客様のアプリケーションに適した TI 製品の選定、(2) お客様のアプリケーションの設計、検証、試験、(3) お客様のアプリケーションに該当する各種規格や、その他のあらゆる安全性、セキュリティ、規制、または他の要件への確実な適合に関する責任を、お客様のみが単独で負うものとし、

上記の各種リソースは、予告なく変更される可能性があります。これらのリソースは、リソースで説明されている TI 製品を使用するアプリケーションの開発の目的でのみ、TI はその使用をお客様に許諾します。これらのリソースに関して、他の目的で複製することや掲載することは禁止されています。TI や第三者の知的財産権のライセンスが付与されている訳ではありません。お客様は、これらのリソースを自身で使用した結果発生するあらゆる申し立て、損害、費用、損失、責任について、TI およびその代理人を完全に補償するものとし、TI は一切の責任を拒否します。

TI の製品は、[TI の販売条件](#)、または ti.com やかかる TI 製品の関連資料などのいずれかを通じて提供する適用可能な条項の下で提供されています。TI がこれらのリソースを提供することは、適用される TI の保証または他の保証の放棄の拡大や変更を意味するものではありません。

お客様がいかなる追加条項または代替条項を提案した場合でも、TI はそれらに異議を唱え、拒否します。

郵送先住所 : Texas Instruments, Post Office Box 655303, Dallas, Texas 75265

Copyright © 2022, Texas Instruments Incorporated