

TI Designs: TIDA-010027

ライン電源型モーション検出器向け低誤報率・低ノイズPIR信号チェーンのリファレンス・デザイン



概要

このリファレンス・デザインでは、ライン電源型アプリケーションの(長距離の検出範囲に対応できる)PIRを使ったモーション検出サブシステムのための低ノイズ・アナログ信号チェーンの設計方法を紹介します。本書では設計理論や部品選定、またノイズ、セトリング・タイム、安定性、および周波数応答に関する回路シミュレーションについて説明します。電源オン・セトリング・タイムの短縮や屋内/外条件の環境要因による誤トリガの低減などの設計目標達成に役立つ回路修正についても説明します。

リソース

- TIDA-010027 デザイン・フォルダ
- TINA-TI SPICEシミュレータ
- TLV9064 プロダクト・フォルダ

E2E™ エキスパートに質問

特長

- 電源オン・セトリング・タイムが短い:25秒未満
- 誤トリガを低減:低カットオフの5次ロールオフと高カットオフの4次ロールオフ
- 回路帯域幅:0.3Hz~6.5Hz
- 出力換算ノイズ:26.4mV未満(ピーク・ピーク)
- 位相マージン:全アンプ段で72°

アプリケーション

- ビデオ監視:
 - 監視/セキュリティ・カメラ
- ビル・セキュリティアラーム・システム:
 - ビデオ・ドアベル、侵入検知、盗難警報器
- HVAC(暖房、換気、空調):
 - サーモスタット、占有検出、ルームモニタ
- 照明:
 - 階段廊下照明制御
- 電化製品:家電:
 - スマートテレビ、冷蔵庫、エアコン、自動販売機
- 衛生機器:
 - 自動便器洗浄装置

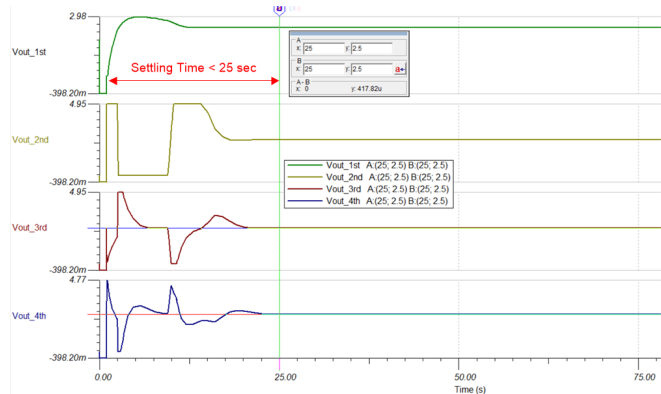
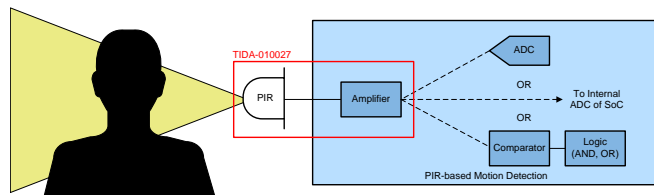



使用許可、知的財産、その他免責事項は、最終ページにあるIMPORTANT NOTICE (重要な注意事項)をご参照くださいますようお願いいたします。

1 System Description

Many industrial and building automation systems use motion detectors to control different functions based on human presence for achieving higher efficiency of those functions by turning them ON only when needed such as lighting control. Surveillance cameras with video analytics based motion detection are always on even if not needed, require high computing power and more complex algorithms to be able to detect motion in challenging situations like poor illumination, dynamic background, shadows, clutter, non-rigid (moving) objects or compression artifacts. Such video surveillance systems produce huge amounts of data for storage, monitoring and display. Long-term human monitoring of the captured video is impractical and ineffective. Thanks to the passive infrared (PIR) sensor technology, use of which allows event based monitoring and recording that reduces storage needs and bandwidth of video surveillance systems.

Motion detector can be either a stand-alone product or a sub-system within a bigger end-equipment such as IP network camera, analog security camera, wireless security camera, thermostat or video doorbell. Some end-equipments are battery powered and some are line powered. The design challenges for a battery operated PIR-based motion detector can be different from that of in a line powered system. For battery operated motion detectors, the designer's primary objective is to minimize the quiescent current of the circuit by utilizing nano-power devices that comes at the expense of decreased sensitivity, higher output noise and reduced motion detection range, which is a fair trade-off to make in the interest of maximizing the battery lifetime. Whereas for a PIR-based motion detector in a line powered system, the main goals would be to achieve high sensitivity, low noise, long range and reliable motion detection in indoor as well as outdoor conditions. Therefore, designer would have the liberty to choose amplifiers having superior 1/f noise performance without too much worrying about quiescent current of the circuit. A passive infrared or pyroelectric infrared (PIR) sensor is mainly used to sense the existence of moving objects in indoor conditions. However, in outdoor conditions, there are often outbreaks of false alarms from environmental changes and other sources. Therefore, it is difficult to provide reliable detection outdoors. Improved circuit configurations and algorithms are required to reduce the risk of false alarms and provide trustworthy trigger signal to surveillance systems. The reference design is more particularly directed to amplification and filter circuitry for faster power-on settling time, reducing false activations and longer detection range. This reference design does not propose any software algorithms, however, briefly discuss about the some logics that might be implemented in software. Motion detector includes PIR sensor and circuitry for amplification and filtering the signal from the sensor. The amplification and filtering circuitry has a pass-band corresponding to a range of speed of a moving heat source in the field of view of the sensor. The ability of the motion detector circuitry to filter-out certain environmental sources of false trigger is enhanced by providing the pass band with a very steep roll-off rate at lower and higher cutoff frequencies. Enabled by Texas Instruments' low-cost, low-noise, quad general purpose amplifiers for amplification and filtering circuitry, this reference design provides fifth order roll-off at lower cut-off and fourth order roll-off at higher cut-off that greatly reduce the risk of false trigger from signals below cut-offs.

This design guide addresses design theory and different circuit simulations that would help system designers in selecting the suitable amplifier and circuit optimization for desired results. The scope of this design guide gives system designers a head-start in integrating low cost, general purpose family of TI's op amps such as TLV900x and TLV906x. The following sub-sections describe the various blocks within the TI Design system and what characteristics are most critical to best implement the corresponding function.

For battery powered PIR-based motion detectors, refer to the reference designs - [TIDA-00489](#), [TIDA-00759](#), [TIDA-01069](#), [TIDA-01398](#) and [TIDA-01476](#).

1.1 Key System Specifications

表 1. Key System Specifications

PARAMETER	SPECIFICATIONS	DETAILS
Operating voltage	2.5 V to 5.5 V	2.3.1
Sensor Type	PIR (Pyroelectric or Passive Infrared)	2.2.2
Power-on circuit settling time	< 25 sec	3.3
Working environment	Indoor and Outdoor	
Phase margin	> 72° for all amplifier stages	3.4
RTO noise	26.4 mV peak-to-peak	3.2
System bandwidth	0.3 Hz to 6.5 Hz	3.1
Amplifier, Filter stages	Four	2.4
Roll-off rates	Fifth order roll-off at lower cut-off and forth order roll-off at higher cut-off	2.4
Operating temperature	-40°C to +85°C	2.3.1

2 System Overview

2.1 Block Diagram

図 1. Typical Block Diagram of a PIR-Based Motion Detector Sub-System

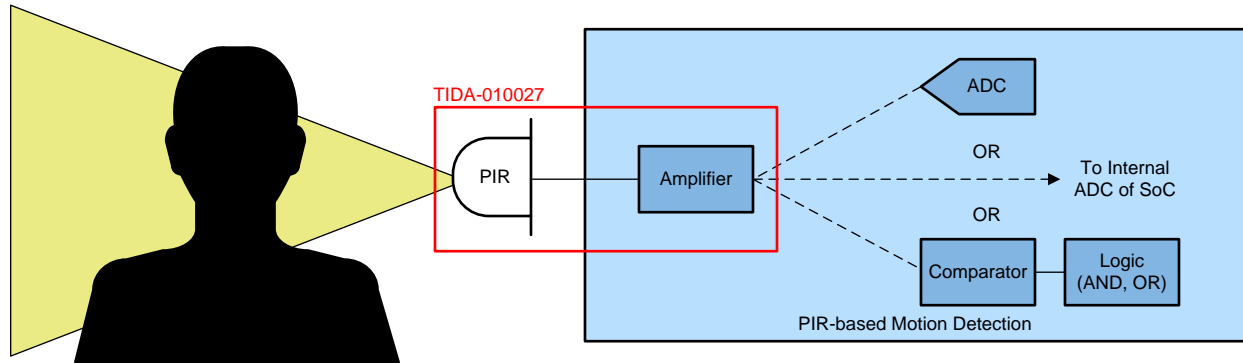

Any PIR-based motion detection circuit consists of several elements each with specific functions.

- Fresnel lens (Optics)
- PIR sensor
- Amplifier and filter
- Decision circuitry (window comparator or ADC)

A Fresnel lens in front of the PIR sensor helps in extending the detection range in a desired field of view by focusing the IR energy onto the small sensor elements in the sensor. PIR sensor detects infrared radiation by making use of the property that the polarization of pyroelectric material changes with temperature, such as that from a human motion. The Amplifier circuitry is mainly needed for two purposes: amplification of the extremely weak signal from sensor and noise filtering before the post digital signal processing, followed by a window comparator or an ADC (internal or external to MPU) for decision making. Use of comparator is the simplest method to detect motion by comparing the amplified signal with pre-set threshold voltages before sending alert to an I/O of the MPU. More advanced motion detectors would need an ADC to realize an intelligent signal processing to be able to run classification algorithm and detect “specific signature” for different kinds of motion in a time-frequency domain, allowing efficient motion detection and false triggering avoidance. 図 1 shows a typical block diagram of PIR-based motion detector sub-system.

2.2 Design Considerations

2.2.1 Fresnel Lens

When a lens is not used in front of a sensor and an IR emitting body is close to the sensor, about 3 or 4 feet and it moves across the front of the sensor, the radiated IR will expose one element more than the other and a voltage output will result. However, when the IR emitting body is further away from the sensor its radiation pattern becomes blurred and both elements are exposed more equally, resulting in no voltage output. The limited detection range is due to a lack of unequal exposure. Therefore, it is necessary to use a lens in front of the sensor to extend the detection range by capturing more IR radiation and focusing it onto the sensor elements. Using a Fresnel lens, the infrared energy for the viewing area is spread across all of the sensor elements. Fresnel lens divides the desired detection area into the segments. Therefore,

the more segments, the better and the greater the size of the Fresnel lens, the better. The sensor is triggered if the heat detected in any segment alters. The segments/patterns can affect the performance of the sensor directly. The lens shape and size, therefore, determines the overall detection angle and viewing area. Ultimately, the choice of lens will be determined by the field of view angle and detection range required by the application.

図 2. (a) Fresnel Lens, (b) Wedge-Shaped Sensory Patterns

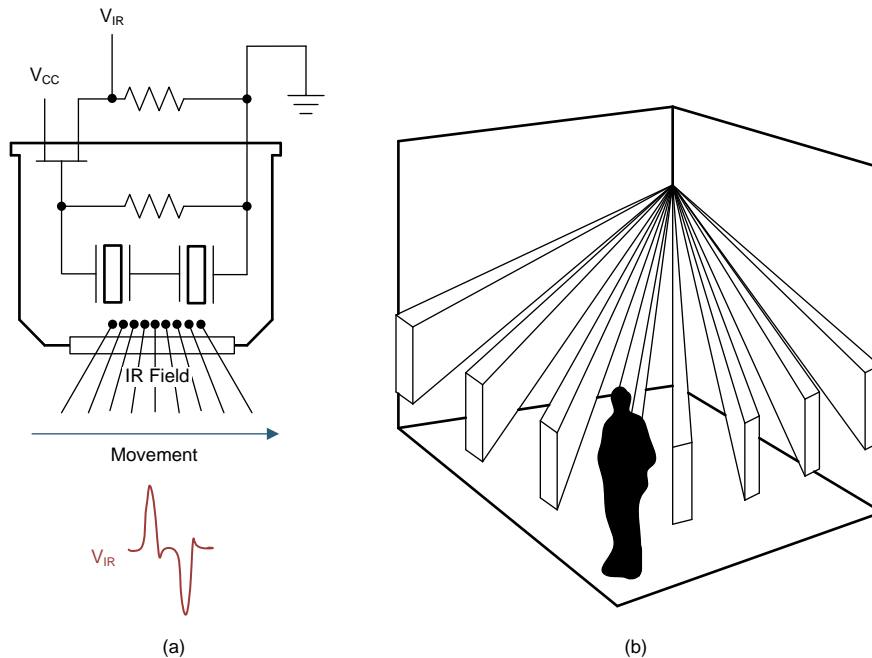

2.2.2 Pyroelectric or Passive Infrared (PIR) Motion Sensor

The pyroelectric material used in a PIR sensor generates an electric charge when subjected to thermal energy flow through its body. The phenomenon is actually a secondary effect of thermal expansion of the pyroelectrics material, which is also piezoelectric. The absorbed heat by the material causes the front side of the sensing element to expand. The resulting thermally induced stress leads to presence of a piezoelectric charge on the element electrodes. This charge shows up as voltage across the electrodes deposited on the opposite sides of the elements. Due to the piezoelectric properties of the element, if the sensor is subjected to a slight mechanical stress by any external force, it generates a charge indistinguishable from that caused by the infrared heat waves. For this reason, the PIR sensors are fabricated symmetrically, as shown in 図 3(b), by placing identical elements inside the package of the sensor. The elements are connected to the electronic circuit in a way to produce out-of-phase signals when subjected to the same in-phase inputs. Hence, spurious heat (or external force) signals applied to both electrodes simultaneously (in phase) will be canceled at the input of the circuit, whereas the variable thermal radiation due to motion of a heat source to be detected will be absorbed by only one element at a time, avoiding cancellation. A JFET transistor is used as a voltage buffer and provides a DC offset at the sensor output as shown in 図 3(d).

図 3. (a) PIR Sensor, (b) PIR Transducer, (c) Output of the PIR Sensor in the Presence of Motion of a Heat Source in the Field-of-View (FOV), and (d) Circuit Representation of PIR Sensor

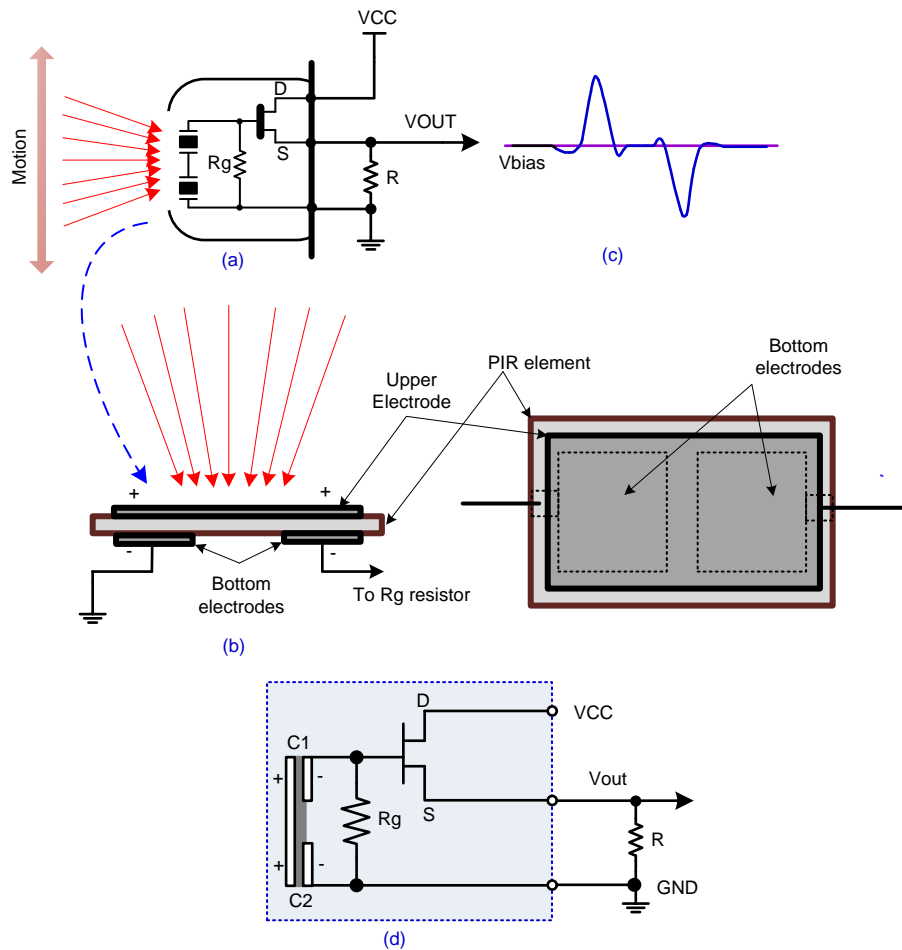

Circuit representation of PIR sensor

The amplitude of the output signal from each sensor indicates the difference in heat (of IR rays) detected by each sensor element which depends upon the speed of the moving target, its distance from the sensor, focal length and pattern design of optical system. Ambient temperature also plays a crucial role in the detection of a moving object. The amplitude of the analog output from a PIR sensor is directly proportional to the difference in temperature of the object and the ambience. 図 1(c) shows the output voltage signal due to a moving object in the field of view of the sensor. The amplitude of this signal is proportional to the speed and distance of the object relative to the sensor and is in a range of a few hundred microvolts V_{pp} up to low millivolts V_{pp} . The best sensor response is achieved if it is physically mounded on the board such that the motions are across the elements. The phase of the output signal generated by the PIR sensor indicates the direction of movement. When the movement is from left to right, the left sensor element of a dual element PIR sensor is triggered first. This generates a positive pulse. When the object crosses the right sensor element, then a negative pulse is generated. Similarly, if the direction of movement is from right to left, the sensor element in the right triggered first which generates a negative pulse, succeeded by a positive pulse by left element. Hence, the direction of movement can be identified observing the behavior of the output signal of the sensor.

図 4.

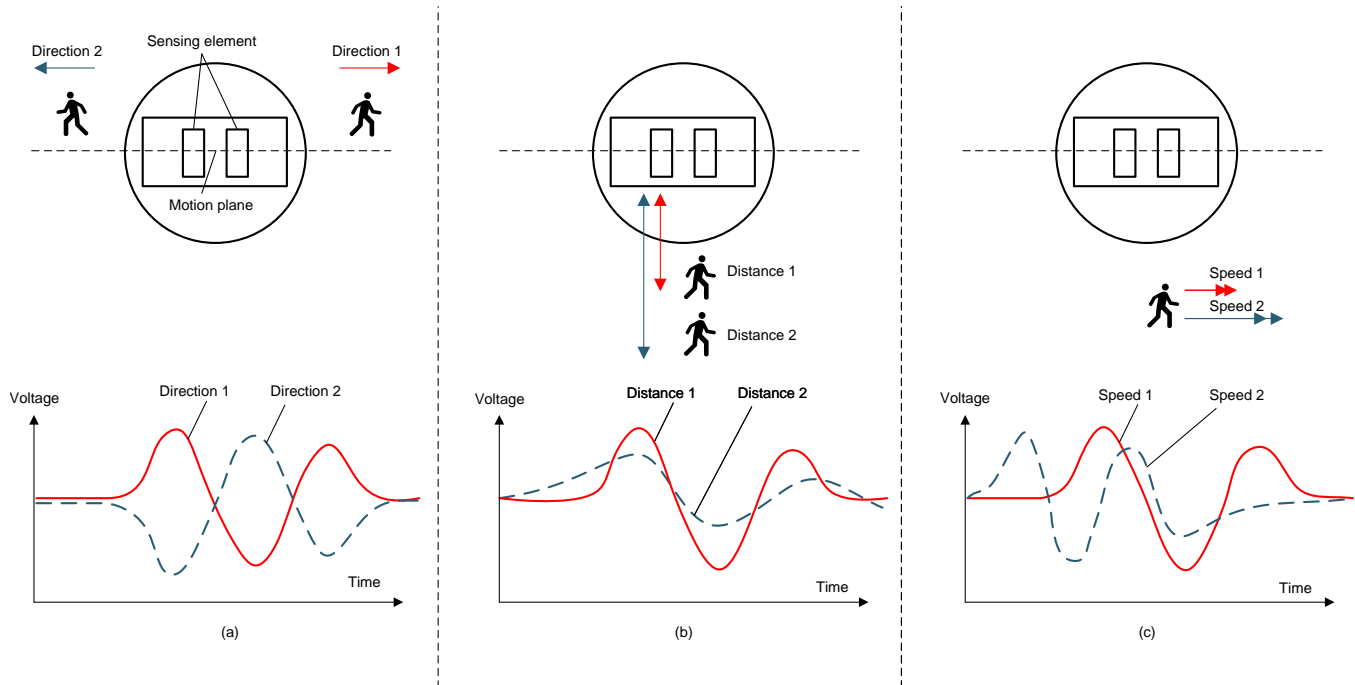

The most common weakness of PIR sensors is that they are vulnerable to sporadic sensing, that means false activation from infrared energy changes that are caused by something other than movement of an intended target, resulting due to slow moving environmental disturbances producing localized thermal imbalance or transport of infrared energy. Such common environmental sources could be rain, gentle breeze sun cycle, sunlight, headlights, passing clouds, rapid change in air temperature due to inflow of warm or cold air from an open window or from an air conditioner or heater, and sensor placed near other sources of time varying heat such as discharge vents and lamps. Thus, it is necessary to develop an improved conditioning circuitry and signal processing algorithms that enhance the ability of motion detector circuitry to filter-out such environmental sources of false trigger.

2.2.3 Frequency Response of PIR Sensor

The output of the PIR sensor responds to a certain frequency range depending on the focal length of optical system, size of sensor element, distance of the target and walking speed as given by 式 1. The low frequency content is generated by the movements at far distances, whereas the high frequency is caused by fast movements close to the sensor. The frequency contents in the output of the PIR sensor needs to be considered at the time of designing the signal condition circuitry. The filter cut-off frequencies should be decided based on how fast and how slow motion needs to be detected in a given application. PIR sensors are able to adapt to different environments and detect more than just human motion. As mentioned earlier also, variations in infrared energy incident upon sensor sometimes originate from undesired sources and can cause false trigger or alarm. One of the known ways of discriminating against such undesired targets is for the amplification and filtering to define a bandpass filter having a pass band corresponding to a range of speeds of a desired target, typically a person. As the person crosses detection zones and dead spaces in the field, the resulting signal from sensor will be characterized by a frequency corresponding to the speed of the intruder. The passband must be set to pass frequencies corresponding to a range of speeds of human movement across the field. Therefore, a bandpass filter helps in eliminating too fast

movements and too slow motions of undesired intruding bodies. Typically, the band pass filter will have a lower cutoff of about 0.3 to 0.8 Hz and an upper cutoff of about 5.0 to 10.0 Hz. Since we are interested in human motion, slow motions range at about 1 meter per second and fast motions can be up to 10 meters per second. As an example, with optics of 25-mm focal length and 1-mm sensor element, these speeds would correspond to a frequency range from 0.3 Hz to 6.5 Hz (approximately).

$$f = \frac{V_b + f_b}{2\pi \times s \times L}$$

where

- f is frequency of the output signal (in Hz)
- V_b is the velocity or moving speed (in m/s)
- f_b is focal length (in mm)
- s is size of the sensing element (in mm)
- L is target distance from the sensor (in m)

(1)

2.2.4 Biasing a PIR Sensor

The low pass filter formed by R1 and C1 on the power supply pin is a critical component because the power supply rejection ratio (PSRR) of the PIR sensor is poor (less than 10 dB). Power supply ripple/noise will be seen as a signal by the gain stages, may result in false triggering at the output. Therefore, a heavy low pass filter helps in absorbing any power supply fluctuations and boosts PSRR of the PIR sensor. Mostly, PIR sensor supply range is from 2 V to 15 V.

The output stage of a typical PIR module is a JFET source follower. The current through the JFET output transistor of the PIR sensor is controlled by an external resistor R2. Resistor (R2) also converts the JFET current to a voltage signal, which also, provides the DC bias for the first amplifier stage. The output of the PIR is a DC voltage with a small AC signal, proportional to the motion of the heat source. The DC voltage varies as the 'background' heat changes, due to lighting, vibration and other factors. Most manufacturers recommend drain current values for the operation of the PIR sensor from 10 μ A to 100 μ A. Typically, the output stage of a PIR sensor is biased by the 47-k Ω resistor to ground. A capacitor connected in parallel to the external resistor (R2) forms a low pass filter that prevents more noise from sensor to in to amplifier stage.

Electromagnetic signals in the air can trigger the PIR-sensor, which can cause false alarms. Panasonic PIR-sensors have a high withstand capability against noise or electromagnetic signals, for example coming from mobile phones, because the sensitive amplifier circuit and filtering elements are already integrated. The risk of false alarm is reduced, using Panasonic PIR sensors compared with conventional PIRs, available in the market. Electromagnetic signals in the air, Wi-Fi, cellphone frequencies or Bluetooth, can trigger the PIR-sensor, which can cause false alarms. Depending on PCB layout and frequency of the RF interference, the output of the PIR sensor picks up more or less signal. The source follower in the sensor performs a demodulation, which yields in a signal representing the envelope of the RF signal interfering with the system. It is recommended to use PIR sensor with integrated filter element for a high withstand capability against noise/electromagnetic signals. This would reduce the risk of false alarm compared to a conventional PIR sensor.

図 5. PIR Sensor Biasing Method

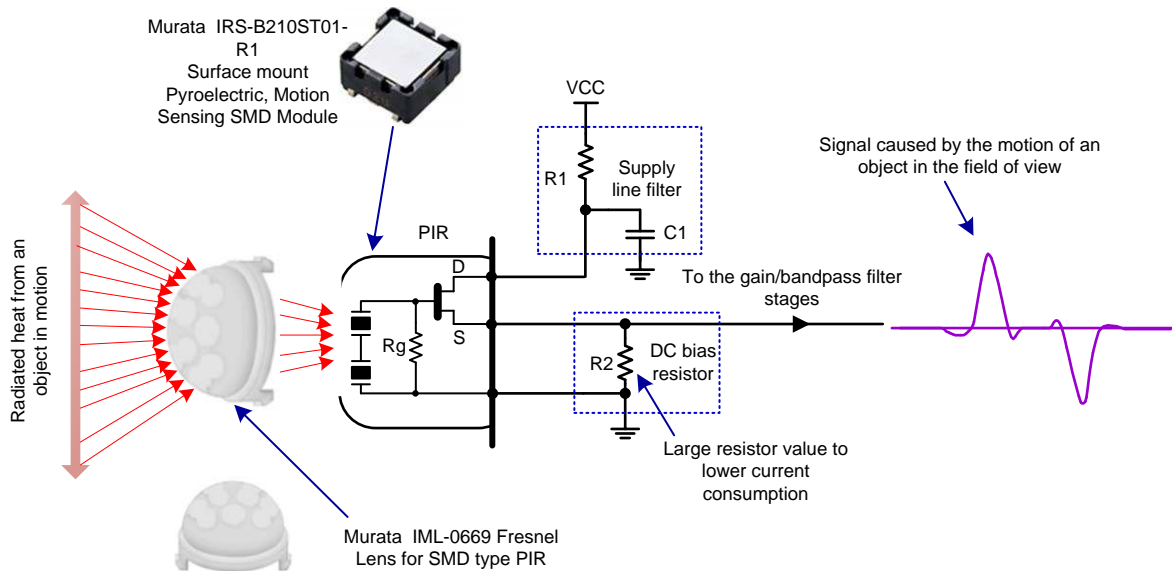

2.2.5 Operational Amplifier

In this TI Design, it is necessary to amplify and filter the signal at the output of the PIR sensor so that the signal amplitudes going into following stages in the signal chain are large enough to provide useful information. Typical signal levels at the output of a PIR sensor are in the micro-volt range for motion of distant objects which exemplifies the need for amplification. The filtering function is necessary to primarily limit the noise bandwidth of the system before reaching the input to the window comparator. Secondly, the filtering function also serves to set limits for the minimum and maximum speed at which the system detects movement. Several considerations must be taken into account for this particular design:

- The op amp should have low $1/f$ noise performance from 0.1 Hz to 10 Hz such that signal conditioning circuit does not degrade sensor S/N ratio.
- The op amp should have low bias current, which allows the use of high value resistance for setting the gains. In addition, since the DC is cancelled for motion detection and only AC signal is amplified, the input offset voltage has no importance.
- The op amp should have sufficient gain bandwidth product (GBP) since AC signal generated by the PIR sensor is amplified by large gains to get a reasonable signal to work with.
- The op amp should feature rail-to-rail operation on the output and at least to negative rail but preferably to both rails on the input.
- The op amp should have integrated RFI and EMI rejection filters on the inputs and power supply pins to reduce sensitivity to unwanted RF signals.
- The op amp should be unity-gain stable because each amplifier stage acts like a unity gain buffer for DC input.

2.3 Highlighted Products

2.3.1 TLV9064

The TLV9061 (single), TLV9062 (dual), and TLV9064 (quad) are single-, dual-, and quad- low-voltage (1.8 V to 5.5 V) operational amplifiers (op amps) with rail-to-rail input- and output-swing capabilities. These devices are highly cost-effective solutions for applications where low-voltage operation, a small footprint, and high capacitive load drive are required. Although the capacitive load drive of the TLV906x is 100 pF, the resistive open-loop output impedance makes stabilizing with higher capacitive loads simpler. These op amps are designed specifically for low-voltage operation (1.8 V to 5.5 V) with performance specifications similar to the OPAx316 and TLVx316 devices.

Features

- Rail-to-rail input and output
- Low input offset voltage: ± 0.3 mV
- Unity-gain bandwidth: 10 MHz
- Low broadband noise: $10 \text{ nV}/\sqrt{\text{Hz}}$
- Low input bias current: 0.5 pA
- Low quiescent current: 538 μA
- Unity-gain stable
- Internal RFI and EMI filter
- Operational at supply voltages as low as 1.8 V
- Easier to stabilize with higher capacitive load due to resistive open-loop output impedance
- Shutdown version: TLV906xS
- Extended temperature range: -40°C to $+125^\circ\text{C}$

Applications

図 6. TLV9064 Functional Block Diagram

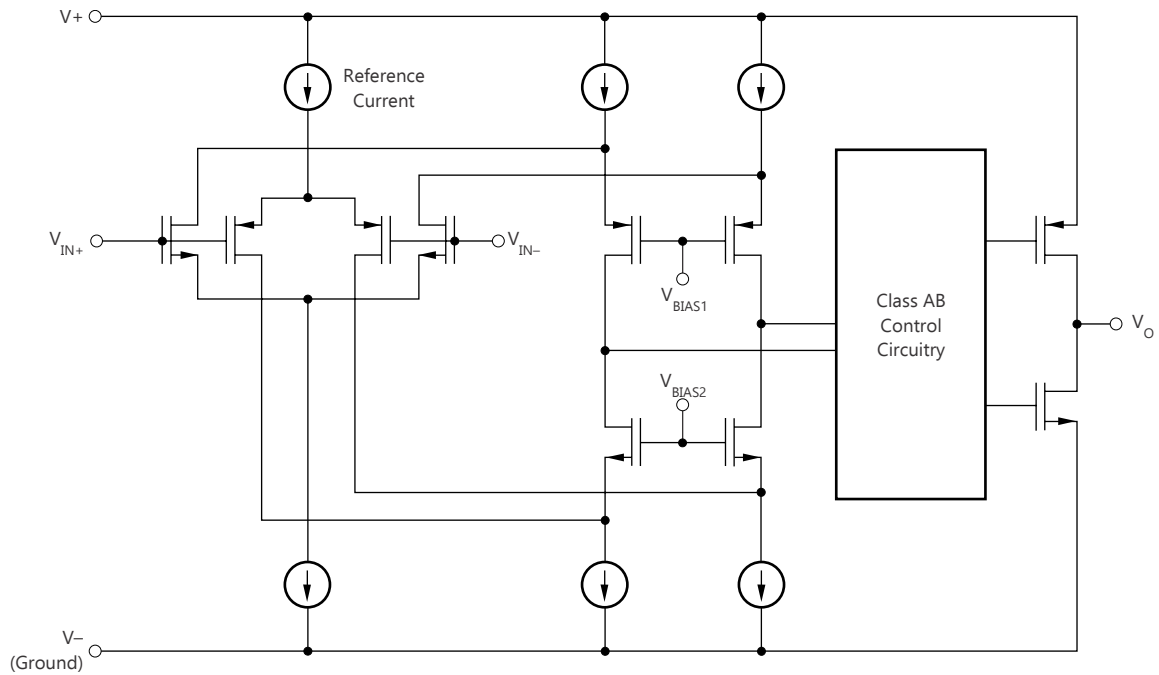

2.4 System Design Theory

When a body with temperature different than the ambient temperature moves into the detection field of view the sensor, the sensor responds with a small AC signal around a DC voltage that may vary significantly from one sensor to another, it is therefore compulsory to cancel the DC part of the signal and amplify the AC part. Typical signal levels at the output of a PIR sensor are in the micro-volt range for motion of distant objects, which exemplifies the need for amplification to get large enough signal to provide useful information. Because the signal is affected by interference from the environment, a noise filter is necessary mainly for two reasons. First, the filtering function is necessary to limit the noise bandwidth of the system before reaching the input to the window comparator. Second, the filtering function sets limits for the minimum and maximum speed at which the system will detect movements.

It has been commonly seen that most PIR-based motion detectors use signal conditioning circuitry that includes two stages of amplification and filtering as it is perceived to give adequate motion detection performance in an indoor environment without added cost and complexity of more stages. However, in an outdoor environment, two stages implementation does not prove to be very effective. Therefore, this reference design proposes amplifier and filter circuitry configured as band-pass filter having four op-amp gain stages. A fourth-order active bandpass filter provides significantly steeper fall-off at the boundaries of the pass band. The steeper bandpass helps in rejecting signals just outside the desired frequency range, thus eliminating false trigger from movements that are too slow or too fast to reasonably correspond to a person moving in the field of view. Particularly on the low end, high pass filter made by C17 and parallel equivalent of R8 and R9 together with high pass filters of four op-amp stages provides fifth-order roll-off greatly reducing false trigger by common environmental factors as localized temperature fluctuations and slowly moving thermal disturbances.

The overall gain of the amplifier circuit controls the sensitivity of the PIR sensor. By changing the sensitivity, it is possible to adjust the range in the field of view (FoV) of sensor. Sensors can detect motion at longer distances when the output signal is amplified with a higher gain due to relatively higher amplitude of the output signal. Thus, the gain plays a crucial role in setting the detection range for PIR sensor in the detection field of view (FoV). The AC signal generated by the PIR sensor is amplified by a gain of 77 dB: 43 dB by the first stage, 34 dB by the second stage, 0 dB by third and fourth stages. This gain (77 dB) has been chosen arbitrarily, hence, may be differ in an end application. The first and second stages provide all the gain required for PIR signal amplification.

図 7. Fourth-Order Signal Condition Circuit for PIR Sensor

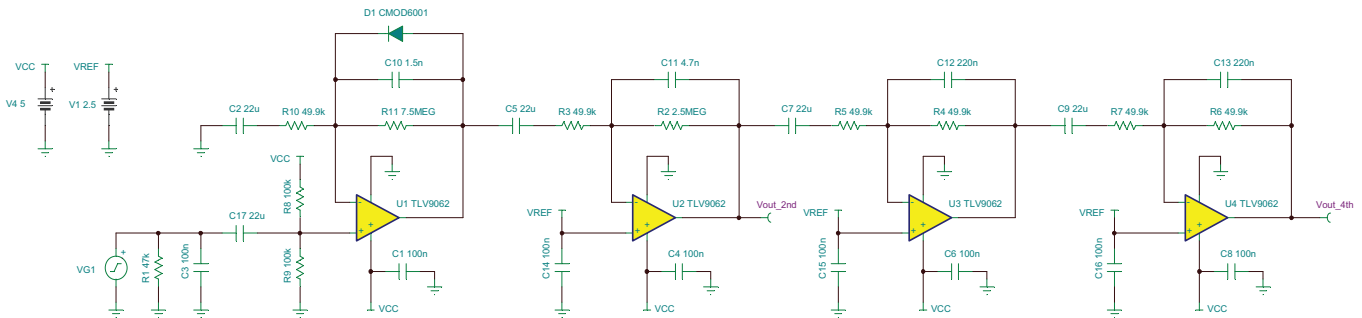

2.4.1 Circuit Design

2.4.1.1 Stage-1

With a power supply of 5 V, the output of the PIR sensor is biased around 1.0 V DC. The first stage amplifies the PIR sensor output. The output of the PIR sensor is AC coupled to the non-inverting input of first stage op amp through the C17 capacitor. The combination of C17, R8, and R9 also forms a high-pass filter blocking low-frequency noise from the sensor to enter amplifier stages. The R8 and R9 resistors also set the common-mode voltage to $VCC / 2 = 2.5$ V. The high-frequency noise is filtered by the R11 and C10 feedback filter, with a cutoff frequency as given by 式 2:

$$f_{high1} = \frac{1}{2\pi \times R11 \times C10} = \sim 14.15\text{Hz} \tag{2}$$

The low frequency noise is filtered by the R10 and C2 high pass filter, with a cutoff frequency as given by 式 3:

$$f_{low1} = \frac{1}{2\pi \times R10 \times C2} = \sim 0.145\text{Hz} \tag{3}$$

Since the PIR sensor output is AC coupled to the first stage op amp, the DC signal of the sensor output is blocked by C17. The op-amp input offset voltage is not amplified and shows-up at the output of the first stage op amp as is. The first stage gain is set by R11 and R10 as given by 式 4:

$$|G1| = \left| 1 + \frac{R11}{R10} \right| = \left| 1 + \frac{7.5\text{ M}\Omega}{49.9\text{ k}\Omega} \right| = \sim 151\text{ V / V} \tag{4}$$

The common-mode voltage at the noninverting input is set to 2.5 V by R8 and R9, so that the input has the largest swing from 0 V to VDD. This gain guarantees the amplified signal will not saturate the first stage op amp, but large enough to distinguish the motion generated signal from the background noise. The main purpose of adding diode D1 in the feedback path is for faster power-on start-up. 3.3 explains the selection of the diode and its working in more details. Actually, the gain bandwidth product (GBP) must be greater than 21.14 kHz ($f_{max} \times \text{gain} \times 10 = 14 \times 151 \times 10 = 21.14$ kHz). The factor 10 has been taken into consideration to have some margin and to be sure not to be limited by the GBP, which is assured by the TLV9064 with a GBP of 10 MHz.

2.4.1.2 Stage-2

The stage-2 is similar to the stage-1 except configured as inverting amplifier. It amplifies the AC component of the signal from stage-1 and rejects the DC component. The high frequency noise is filtered by R2 and C11 feedback filter, with a cutoff frequency as given by 式 5:

$$f_{high2} = \frac{1}{2\pi \times R2 \times C11} = \sim 13.55\text{ Hz} \tag{5}$$

The low frequency noise is filtered by the R3 and C5 high pass filter, with a cutoff frequency as given by 式 6:

$$f_{low2} = \frac{1}{2\pi \times R10 \times C2} = \sim 0.145 \text{ Hz} \quad (6)$$

The second stage gain is set by R2 and R3 as given by 式 7:

$$|G2| = \left| -\frac{R2}{R3} \right| = \left| -\frac{2.5 \text{ M}\Omega}{49.9 \text{ k}\Omega} \right| = \sim 50 \text{ V / V} \quad (7)$$

Similar to the first stage, the input offset voltage does not matter because only AC is amplified. The common-mode voltage at the non-inverting input is set to 2.5 V, so that the input has the largest swing from 0 V to VDD. The circuit has a GBP requirement of 14 Hz × 50 × 10 = 7 kHz, which is assured by the TLV9064 with a GBP of 10 MHz.

2.4.1.3 Stage-3 and Stage-4

The stage-3 and stage-4 have also been configured in inverting configuration with unity gains to pass the AC signal amplified by stage-1 and stage-2 and reject the DC components. The only purpose of stage-3 and stage-4 is to make the frequency roll-off steeper. The high frequency noise is filtered by R4 and C12 low pass filter in stage-3 and by R6 and C13 low pass filter in stage-4, with a cutoff frequencies as given by 式 8:

$$f_{high3} = \frac{1}{2\pi \times R4 \times C12} = \sim 14.5 \text{ Hz}$$

$$f_{high4} = \frac{1}{2\pi \times R6 \times C13} = \sim 14.5 \text{ Hz} \quad (8)$$

The low frequency noise is filtered by R5 and C7 high pass filter in stage-3 and by R7 and C9 high pass filter in stage-4, with a cutoff frequencies as given by 式 9:

$$f_{low3} = \frac{1}{2\pi \times R5 \times C7} = \sim 0.145 \text{ Hz}$$

$$f_{low4} = \frac{1}{2\pi \times R7 \times C9} = \sim 0.145 \text{ Hz} \quad (9)$$

The gain of stage-3 and stage-4 are set by R4 & R5 and R6 & R7, respectively, as given by 式 10:

$$|G3| = \left| -\frac{R4}{R5} \right| = \left| -\frac{49.9 \text{ k}\Omega}{49.9 \text{ k}\Omega} \right| = \sim 1 \text{ V / V}$$

$$|G4| = \left| -\frac{R6}{R7} \right| = \left| -\frac{49.9 \text{ k}\Omega}{49.9 \text{ k}\Omega} \right| = \sim 1 \text{ V / V} \quad (10)$$

Similar to the all previous stages, the input offset voltage of op amps does not matter because only AC is amplified. The common-mode voltage at the noninverting input is set to 2.5 V, so that the input has the largest swing from 0 V to VDD. The circuit has a GBP requirement of 14 Hz × 1 × 10 = 140 Hz, which is comfortably assured by the TLV9064 with a GBP of 10 MHz.

3 Simulation and Results

3.1 Frequency Response

図 8. Frequency Response Dual vs Quad Stages (Logarithmic Scale)



図 9. Frequency Response Dual vs Quad Stages (Linear Scale)



3.2 Noise

From simulation, the total integrated noise of the signal conditioning circuit over system bandwidth from 0.3 Hz to 6.5 Hz is three times lesser than the PIR sensor noise. That means signal conditioning circuit design here does not degrade the signal-to-noise ratio of the sensor and aids in maintaining the detection range as rated by Fresnel lens. Total integrated referred-to-output (RTO) noise for the proposed signal conditioning circuit is 4 mV RMS or 26.4 mV peak-to-peak.

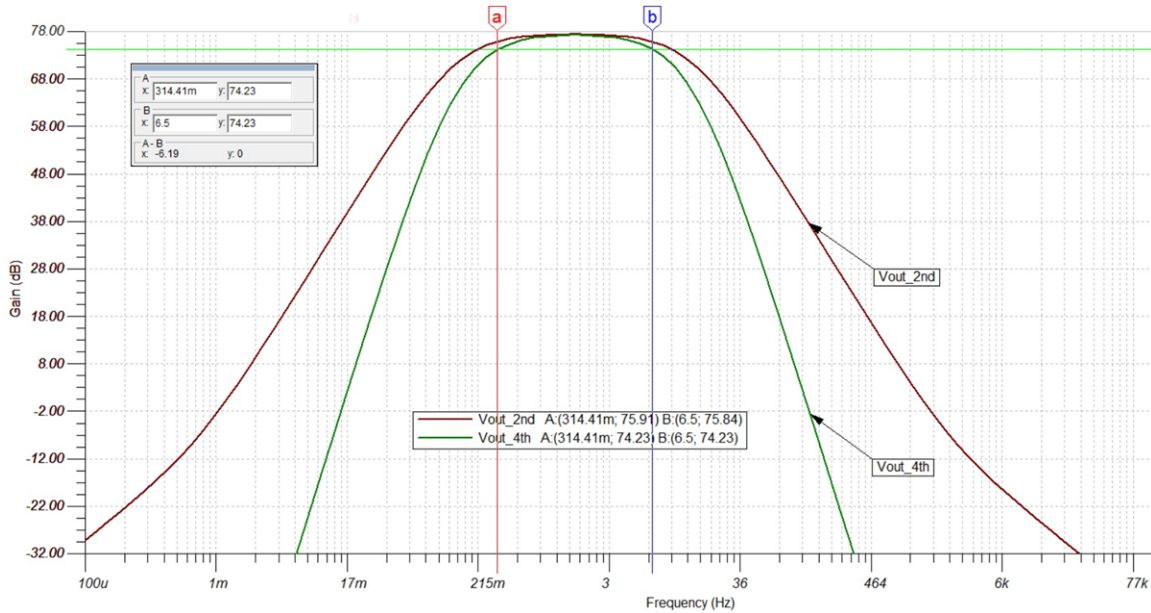
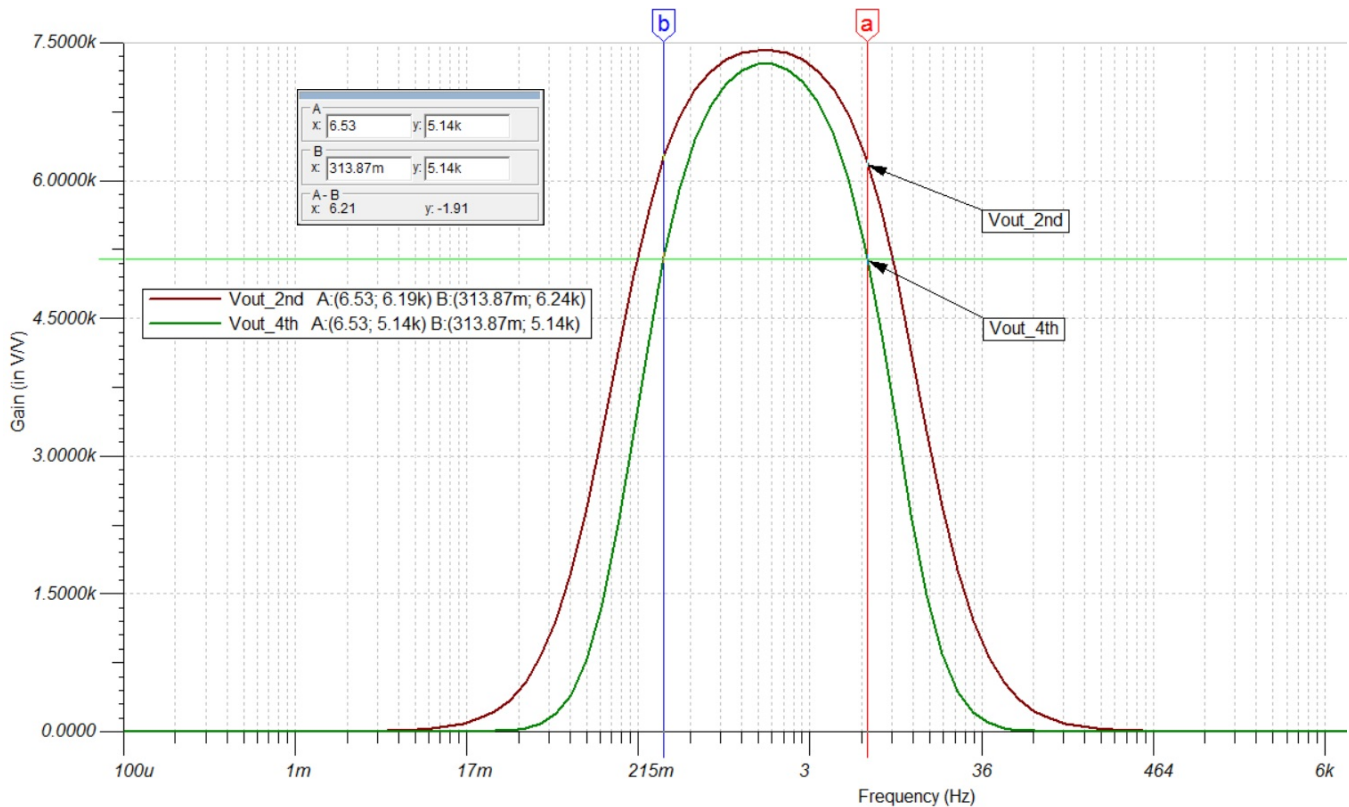
図 10. Integrated Noise of Signal Conditioning Circuit

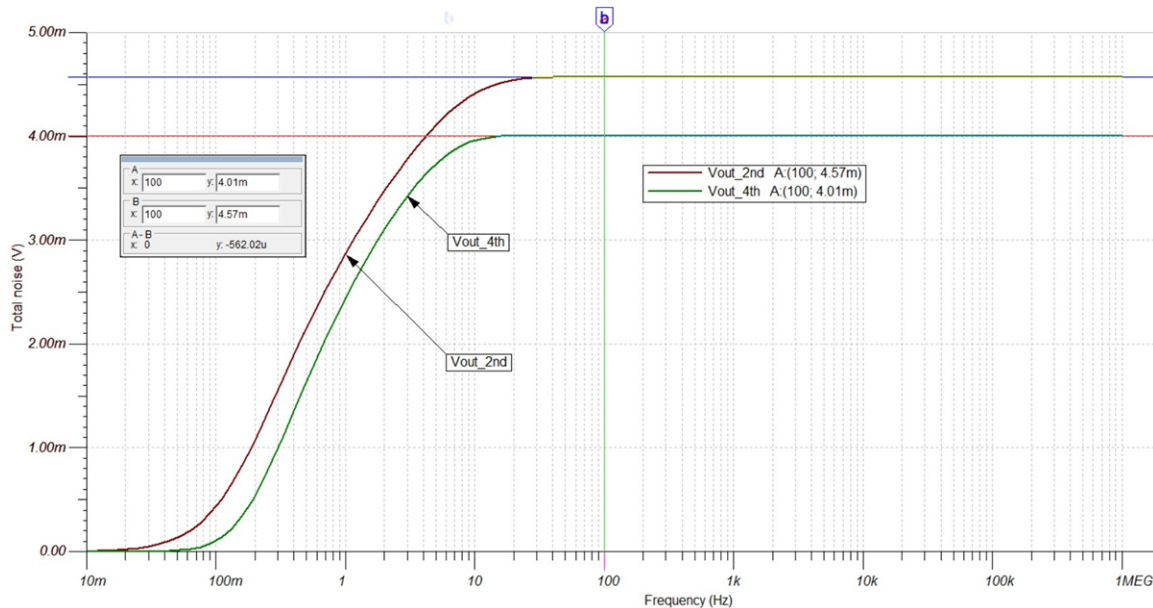

3.3 Power-on Settling Time

図 11 shows the TINA-TI schematic used to simulate the power-on settling time functionality of the circuit using the TLV9064 amplifier. The first stage amplifier filter takes more time to settle compared to the successive amplifier and filter stages. This is because first stage amplifier provides most of the system gain by having large value resistor in the feedback path resulting in large RC time constant.

図 11. TINA Schematic for Settling Time Simulation With and Without Diode



図 12. Charging Path for C2 Without Diode

Voltage at the inverting pin cannot rise to $VCC/2$ immediately after power on due to the large time constant of the RC circuit. The amplifier goes into positive saturation.



図 13. Power-on Settling Time Simulation Without Diode

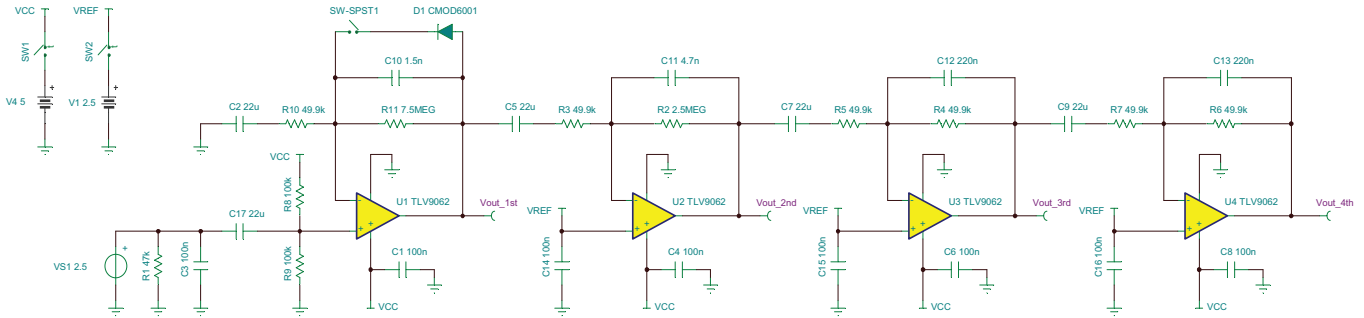

図 14. Charging Path With Diode in the Feedback

With diode in the feedback path, voltage at the inverting pin rises rapidly and helps the amplifier to come out of saturation much faster than earlier.

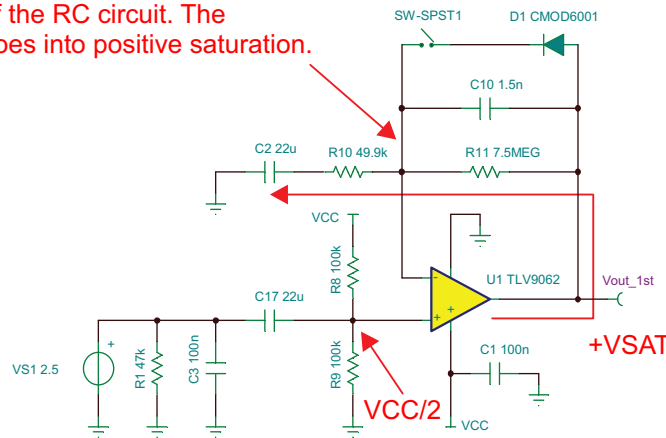

図 15. Power-on Settling Time Simulation With Diode

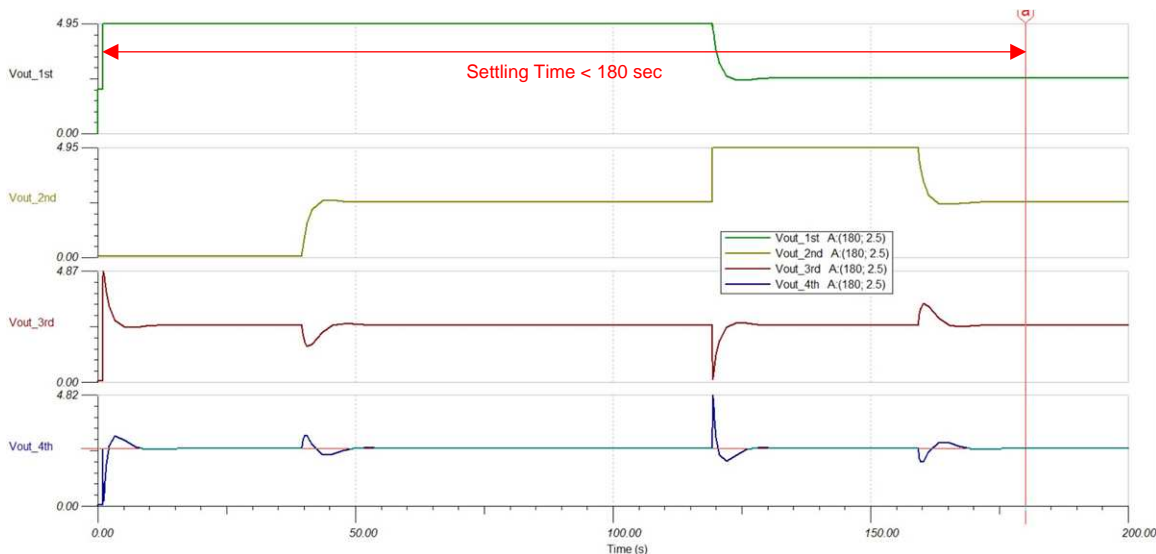

Adding a diode in parallel with a large feedback resistor provides a low resistance path for charging the 22- μ F capacitor (C2), which allows first stage amplifier to come out of saturation much faster. This small modification shows a huge improvement in the power-on settling time of amplification and filtering circuitry from 180 seconds to 25 seconds, which is even smaller than the maximum settling time for most PIR sensors. Faster power-on settling time helps in quicker functional checks after installation without waiting for long time for the circuit to become operational. Faster power-on settling time is also critical for systems where motion detector is also power-cycled quite often.

3.4 Stability

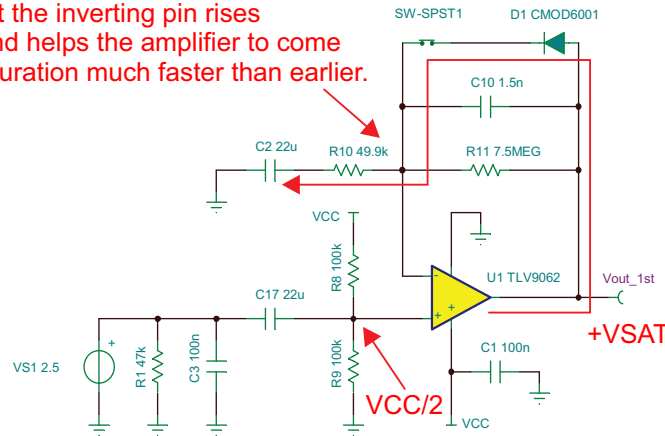
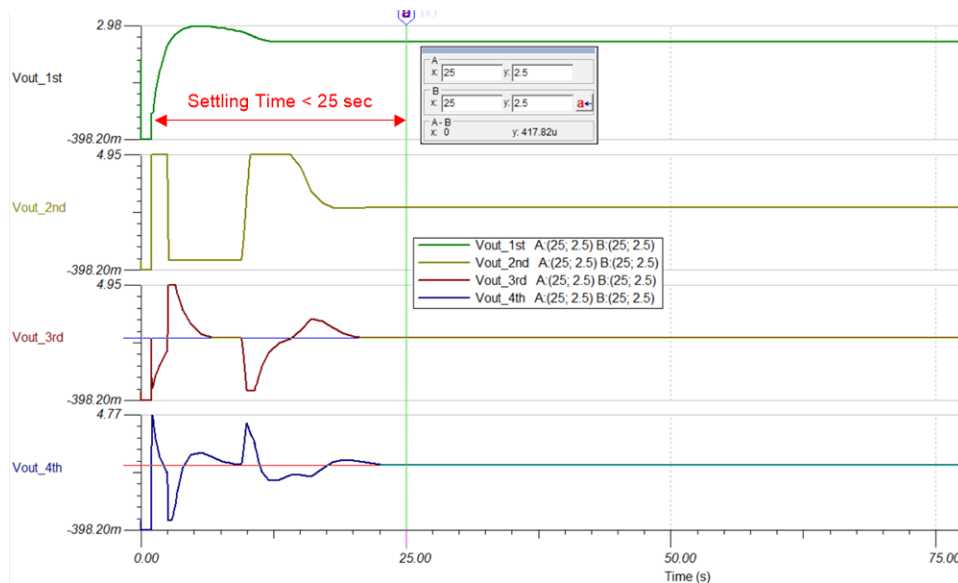
The main components for this test bench are L1 and C2 with AC source VG2. C2 provides an open circuit at DC where L1 provides a short circuit to close the loop and establish the DC operating point. Under AC conditions, C2 will be a short circuit while L1 will be an open circuit, thereby opening the loop for stability analysis. Probe Aol as the name implies will show the open loop gain response of the op amp, while probe AolB will show the loop gain of the circuit. Similarly, Aol/Aol × Beta shows the response of 1/Beta for the feedback loop.

図 16. Test Circuit for Stage-1 Stability Analysis



図 17. Bode Plot for Stability Analysis of Stage-1



図 18. Test Circuit for Stage-2 Stability Analysis

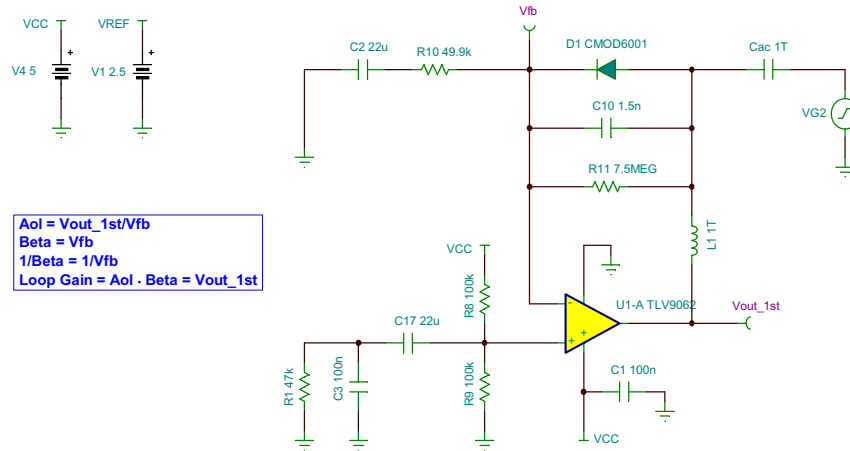

図 19. Bode Plot for Stability Analysis of Stage-2

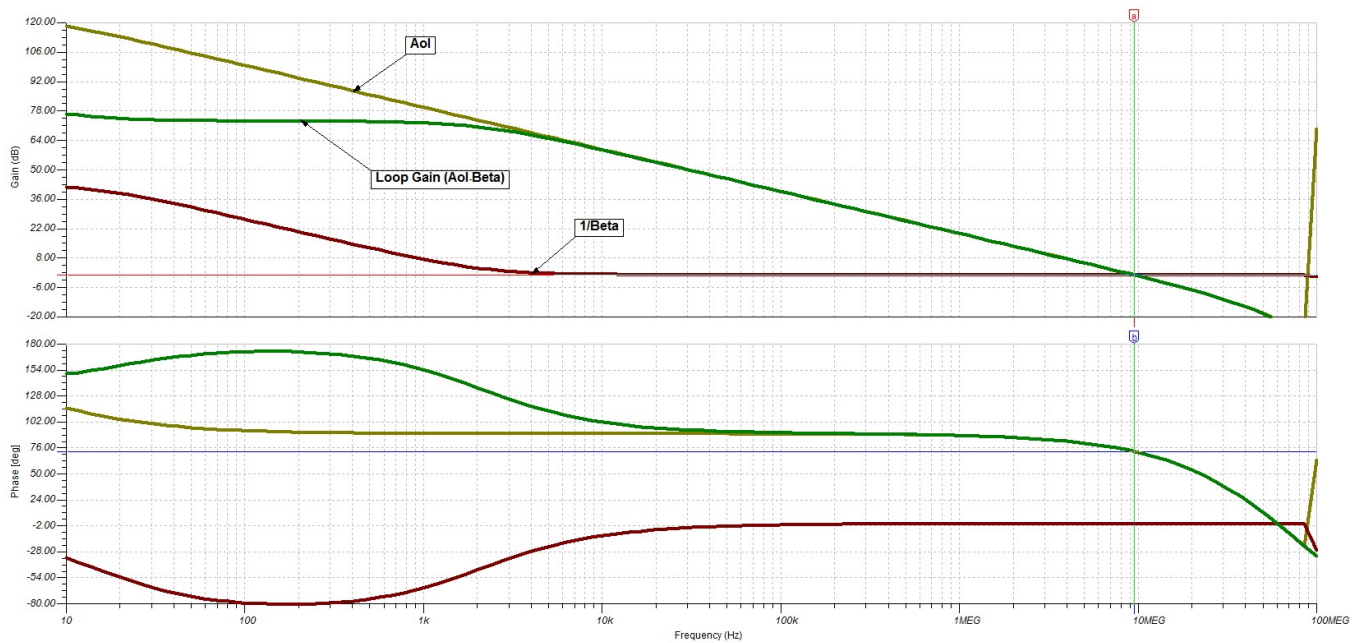

図 20. Test Circuit for Stage-3 Stability Analysis

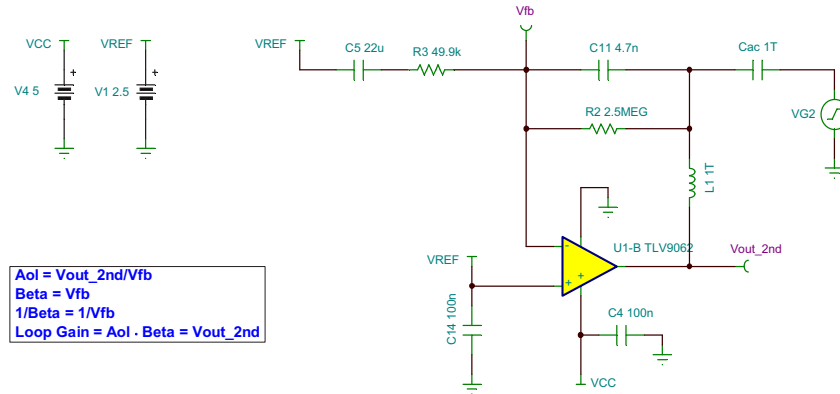

図 21. Bode Plot for Stability Analysis of Stage-3

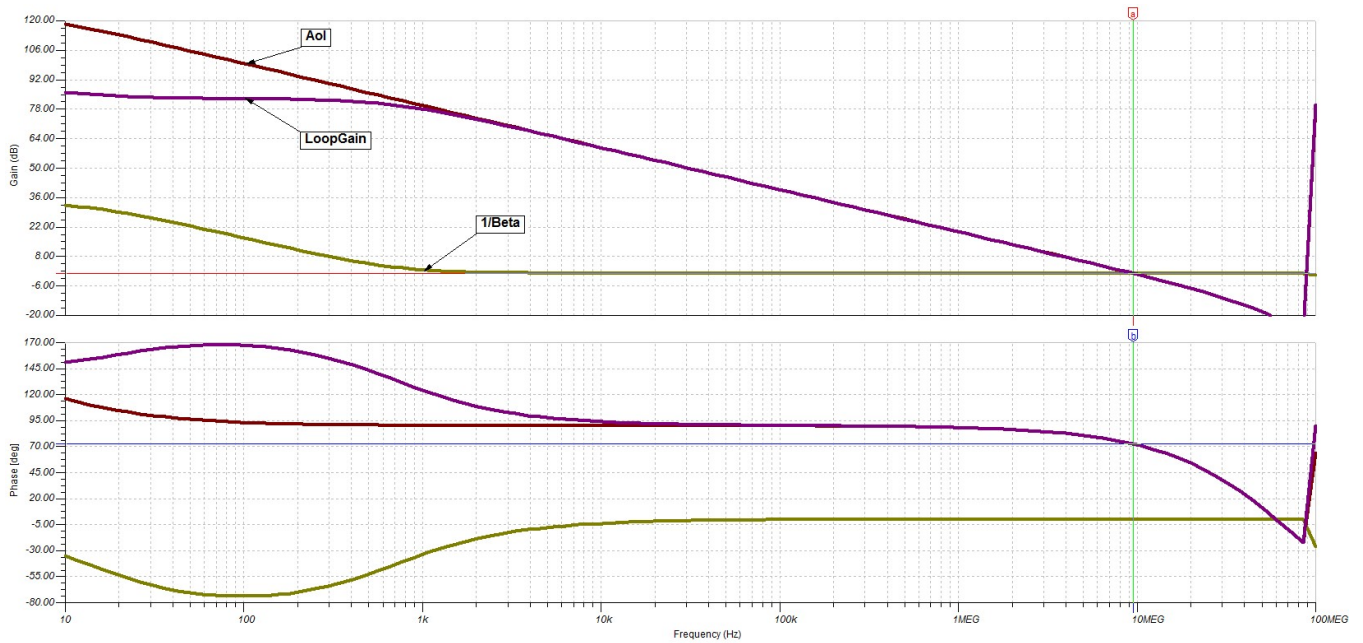

Stage-4 is exactly the same as stage-3, so the phase margin also remains the same. 図 16, 図 18, and 図 20 show the small signal stability frequency response of the circuit. As 図 17, 図 19, and 図 21 show, all amplifier stages (Stage-1, Stage-2, Stage-3, and Stage-4) of the signal conditioning circuit are stable with a phase margin of greater than 72° , respectively.

4 Design Files

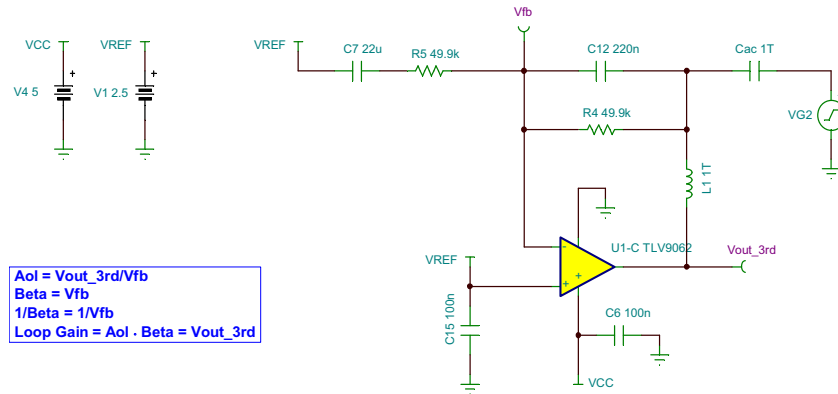
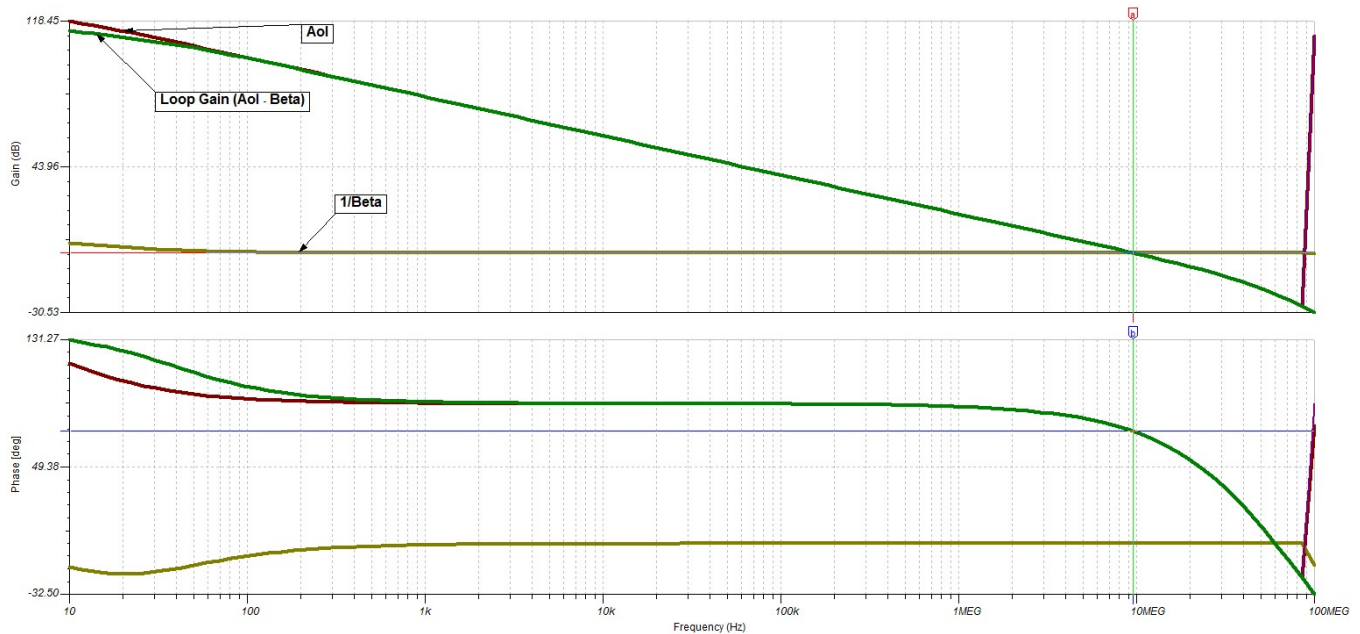
4.1 Simulation Files

To download the TINA-Ti simulation files, see the design files at [TIDA-010027](#).

4.2 Bill of Materials

To download the bill of materials (BOM), see the design files at [TIDA-010027](#).

5 Related Documentation

1. Texas Instruments, [TLV906xS 10-MHz, RRIO, CMOS Operational Amplifiers for Cost-Sensitive Systems Data Sheet](#)
2. Texas Instruments, [TI Precision Labs - Op Amps](#)

5.1 商標

E2E is a trademark of Texas Instruments.

6 About the Author

Sharad Yadav is a systems architect at TI India, where he is responsible for developing reference design solutions for the industrial segment. Sharad has twelve years of experience in high-speed digital, mixed-signal boards, low-noise analog, and EMI/EMC protection circuit design.

重要なお知らせと免責事項

TI は、技術データと信頼性データ(データシートを含みます)、設計リソース(リファレンス・デザインを含みます)、アプリケーションや設計に関する各種アドバイス、Web ツール、安全性情報、その他のリソースを、欠陥が存在する可能性のある「現状のまま」提供しており、商品性および特定目的に対する適合性の黙示保証、第三者の知的財産権の非侵害保証を含むいかなる保証も、明示的または黙示的にかかわらず拒否します。

これらのリソースは、TI 製品を使用する設計の経験を積んだ開発者への提供を意図したものです。(1) お客様のアプリケーションに適した TI 製品の選定、(2) お客様のアプリケーションの設計、検証、試験、(3) お客様のアプリケーションが適用される各種規格や、その他のあらゆる安全性、セキュリティ、またはその他の要件を満たしていることを確実にする責任を、お客様のみが単独で負うものとします。上記の各種リソースは、予告なく変更される可能性があります。これらのリソースは、リソースで説明されている TI 製品を使用するアプリケーションの開発の目的でのみ、TI はその使用をお客様に許諾します。これらのリソースに関して、他の目的で複製することや掲載することは禁止されています。TI や第三者の知的財産権のライセンスが付与されている訳ではありません。お客様は、これらのリソースを自身で使用した結果発生するあらゆる申し立て、損害、費用、損失、責任について、TI およびその代理人を完全に補償するものとし、TI は一切の責任を拒否します。

TI の製品は、TI の販売条件 (www.tij.co.jp/ja-jp/legal/termsofsale.html)、または ti.com やかかる TI 製品の関連資料などのいずれかを通じて提供する適用可能な条項の下で提供されています。TI がこれらのリソースを提供することは、適用される TI の保証または他の保証の放棄の拡大や変更を意味するものではありません。

Copyright © 2018, Texas Instruments Incorporated
日本語版 日本テキサス・インスツルメンツ株式会社

重要なお知らせと免責事項

TI は、技術データと信頼性データ(データシートを含みます)、設計リソース(リファレンス・デザインを含みます)、アプリケーションや設計に関する各種アドバイス、Web ツール、安全性情報、その他のリソースを、欠陥が存在する可能性のある「現状のまま」提供しており、商品性および特定目的に対する適合性の黙示保証、第三者の知的財産権の非侵害保証を含むいかなる保証も、明示的または黙示的にかかわらず拒否します。

これらのリソースは、TI 製品を使用する設計の経験を積んだ開発者への提供を意図したものです。(1) お客様のアプリケーションに適した TI 製品の選定、(2) お客様のアプリケーションの設計、検証、試験、(3) お客様のアプリケーションが適用される各種規格や、その他のあらゆる安全性、セキュリティ、またはその他の要件を満たしていることを確実にする責任を、お客様のみが単独で負うものとします。上記の各種リソースは、予告なく変更される可能性があります。これらのリソースは、リソースで説明されている TI 製品を使用するアプリケーションの開発の目的でのみ、TI はその使用をお客様に許諾します。これらのリソースに関して、他の目的で複製することや掲載することは禁止されています。TI や第三者の知的財産権のライセンスが付与されている訳ではありません。お客様は、これらのリソースを自身で使用した結果発生するあらゆる申し立て、損害、費用、損失、責任について、TI およびその代理人を完全に補償するものとし、TI は一切の責任を拒否します。

TI の製品は、TI の販売条件 (www.tij.co.jp/ja-jp/legal/termsofsale.html)、または ti.com やかかる TI 製品の関連資料などのいずれかを通じて提供する適用可能な条項の下で提供されています。TI がこれらのリソースを提供することは、適用される TI の保証または他の保証の放棄の拡大や変更を意味するものではありません。

Copyright © 2018, Texas Instruments Incorporated
日本語版 日本テキサス・インスツルメンツ株式会社