

TI Designs: TIDA-01559

容量性タッチ・ベース、近接センシングおよびLEDアニメーション付きのユーザー・インターフェイスのリファレンス・デザイン



概要

TIDA-01559はヒューマン・マシン・インターフェイス(HMI)のリファレンス・デザインで、MSP430FR2522 MCUとLP5569 LEDドライバを使用し、スタンバイ時消費電力が非常に低く、MCUのリソースをLEDエンジン制御の負荷から解放できます。このソリューションは、優れたEMI特性と湿度への耐性が要求される、あらゆる低消費電力HMI、たとえばキッチンの排気フード、調理用コンロ、冷蔵庫などに使用できます。

リソース

TIDA-01559	デザイン・フォルダ
LP5569	プロダクト・フォルダ
MSP430FR2522	プロダクト・フォルダ
TLV733P	プロダクト・フォルダ

特長

- プリセットの照明パターンの実行時にMCU負荷が最小限
- LP5569エンジン制御によりシステムの消費電流を低減
- スタンバイ・モードでの非常に低い静止電流
- 完全な診断機能と保護機能
- 湿度への優れた耐性

アプリケーション

- キッチンの排気フード
- 調理用コンロ
- 冷蔵庫や冷凍庫
- ロボット掃除機
- エレベーター



E2E™ エキスパートに質問

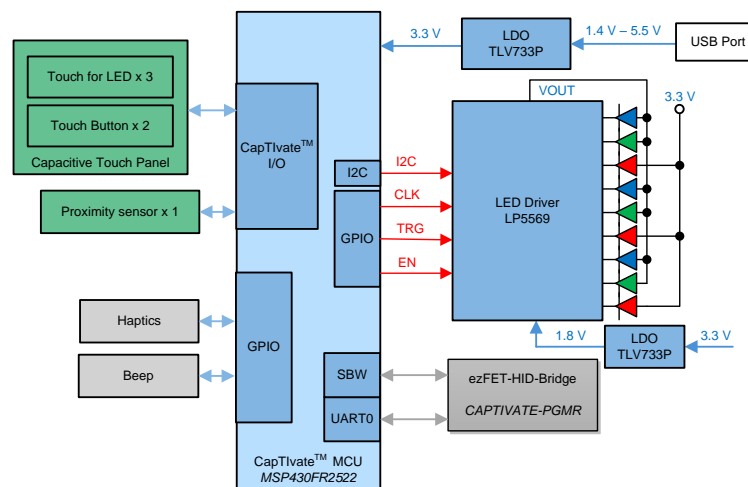

使用許可、知的財産、その他免責事項は、最終ページにあるIMPORTANT NOTICE (重要な注意事項)をご参照くださいようお願いいたします。

1 System Description

In an industrial system, especially in home appliance applications, end equipment makers care more and more about reliability and how to make their products more attractive. Using TI's single MSP430™ microcontroller (MCU) with CapTIvate™ and advanced LED driver technology, it is easier to make products unique and impressive. Based on this TI design you will know how the system design with TI components enable full protection and certification, which give a competitive advantage by helping you to qualify the end equipment for requirements as per the standards.

The general advantages of this design are as follows:

- Minimum MCU loading when running preset lighting pattern
- Lower system current consumption through the LP5569 engine control
- Extra low quiescent current during standby mode
- Full diagnostic and protection
- Good moisture immunity

1.1 Key System Specifications

表 1. Key System Specifications

PARAMETER	MIN	NOM	MAX	UNIT
DC input voltage	1.4	3.3	5.5	V
Standby current (MCU)			15	μA
Standby current (LED driver)			50	μA
High-accuracy current sinks	8-bit individual current control (25.5 mA maximum)			
LED engines	Independent illumination control without active microcontroller control			
Dimming control	1) PWM, 2) Engines, 3) Register			
Audible noise	12-bit 20-kHz internal individual PWM control			
Protection	Input UVLO, TSD (OTP)			

2 System Overview

2.1 Block Diagram

Figure 1 illustrates the TIDA-01559 block diagram.

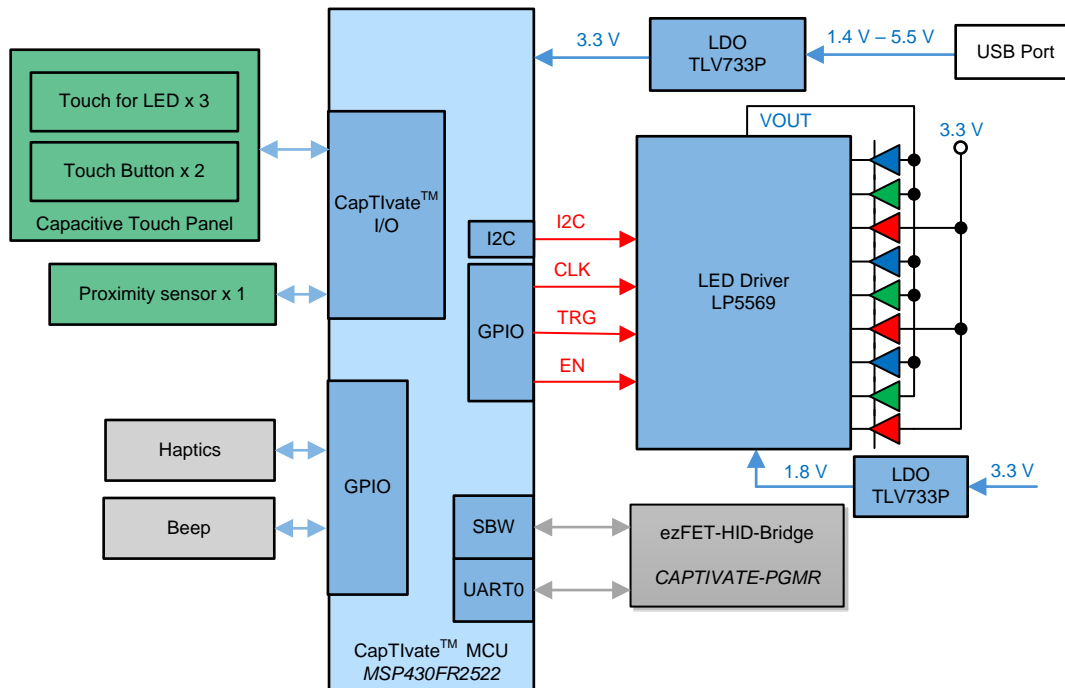

Figure 1. TIDA-01559 Block Diagram

2.2 Highlighted Products

The following subsections detail the highlighted products used in this reference design, including the key features for their selection. See their respective product data sheets for complete details on any highlighted device. Link to a ti.com document

2.2.1 MSP430FR2522

The MSP430FR25x2 is a family of ultra-low-power MSP430™ micro controllers (MCUs) for capacitive touch sensing that feature CapTIvate touch technology for cost-sensitive applications featuring 1 to 16 capacitive buttons or proximity sensing. The MSP430FR25x2 MCUs offer value and performance for industrial applications exposed to electromagnetic disturbances, oil, water, and grease. The devices offer IEC-certified solutions with 5x lower power consumption than the competition and support proximity sensing as well as touch through glass, plastic, and metal overlays. TI capacitive touch sensing MSP430 MCUs are supported by an extensive hardware and software ecosystem with reference designs and code examples to get your design started quickly. The BOOSTXLCAPKEYPAD BoosterPack™ plug-in module can be used with the CAPTIVATE-PGMR programmer board (standalone or as part of the MSP-CAPT-FR2633 CapTIvate development kit) or with the LaunchPad™ development kit ecosystem. TI also

provides free software including the [CapTIvate Design Center](#), where engineers can quickly develop applications with an easy-to-use GUI and MSP430Ware™ software, and comprehensive documentation with the [CapTIvate™ Technology Guide](#). MSP430 MCUs with CapTIvate technology provide the most integrated and autonomous capacitive-touch solutions in the market with high reliability and noise immunity at the lowest power. For more information visit www.ti.com/captivate.

図 2 shows the MSP430FR2522 functional block diagram.



図 2. MSP430FR2522 Functional Block Diagram

2.2.2 LP5569

The LP5569 device is a programmable, easy-to-use 9-channel I²C LED driver designed to produce lighting effects for various applications. The LED driver is equipped with an internal SRAM memory for user programmed sequences and three programmable LED engines, which allow operation without processor control. Autonomous operation reduces system power consumption when the processor is put in sleep mode.

A high-efficiency charge pump enables the driving of LEDs with high VF, even with 2.5-V input voltage. The LP5569 LED driver maintains good efficiency over a wide operational voltage range by autonomously selecting the best charge-pump gain based on LED forward voltage requirements.

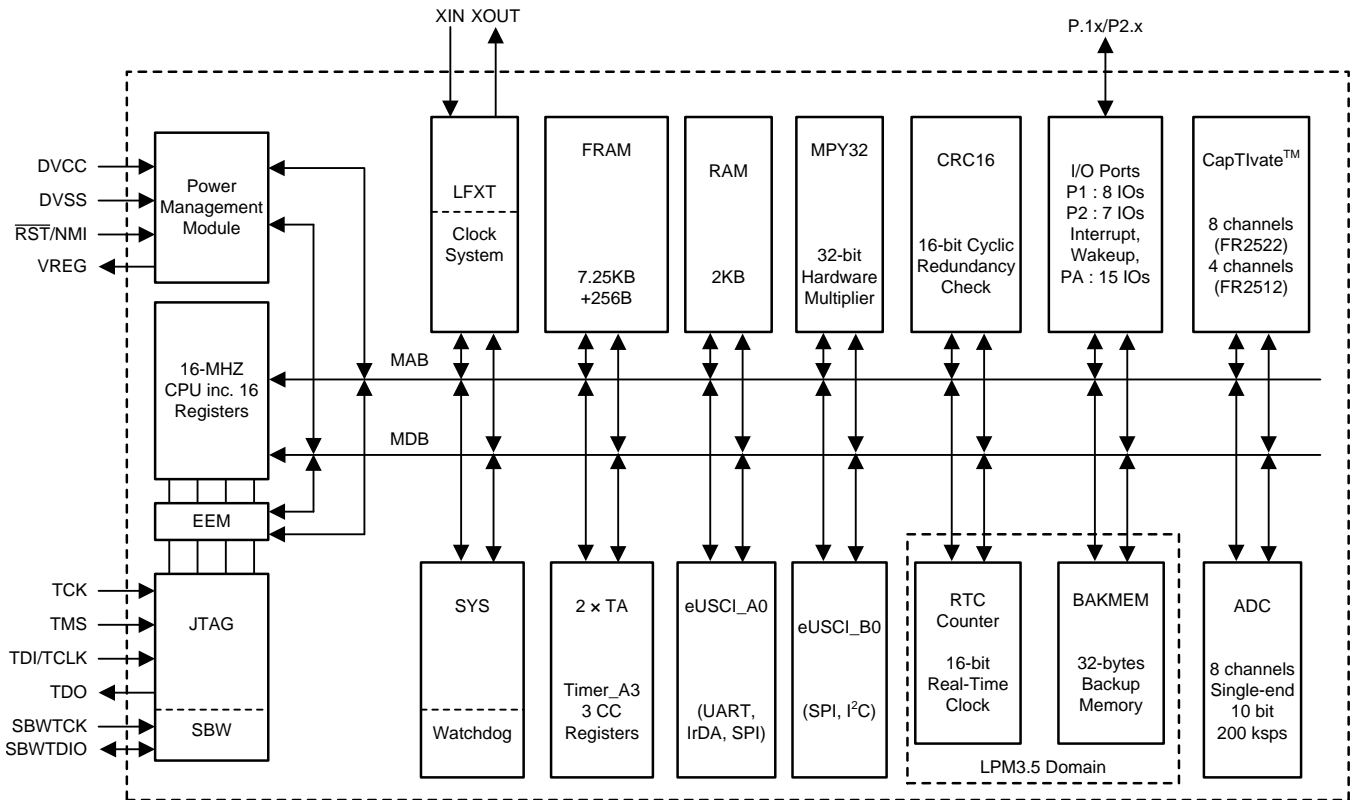
The LP5569 device enters power-save mode when LEDs are not active, lowering idle-current consumption considerably. A flexible digital interface allows the connection of up to eight LP5569 devices with a unique I²C slave address for each device in the same system, which supports synchronization of the lighting effects among all devices.

2.2.3 TLV733P

The TLV733 series of low-dropout linear regulators (LDOs) are ultra-small, low quiescent current LDOs that can source 300 mA with good line and load transient performance. These devices provide a typical accuracy of 1%.

The TLV733 series is designed with a modern capacitor-free architecture to ensure stability without an input or output capacitor. The removal of the output capacitor allows for a very small solution size, and can eliminate inrush current at startup. However, the TLV733 series is also stable with ceramic output capacitors if an output capacitor is necessary. The TLV733 also provides foldback current control during device power-up and enabling if an output capacitor is used. This functionality is especially important in battery-operated devices.

The TLV733 provides an active pull-down circuit to quickly discharge output loads when disabled.

The TLV733 series is available in standard DBV (SOT-23) and DQN (X2SON) packages.

2.3 System Design Theory

The LP5569 device is a fully-integrated lighting management unit for producing lighting effects for various LED applications. The LP5569 device includes all necessary power management, low-side current sinks, two-wire serial I²C-compatible interface, and programmable LED engines. The overall maximum current for each of the nine drivers is set with 8-bit resolution. The LP5569 device controls LED luminance with a pulse-width modulation (PWM) scheme with a resolution of 12 bits at 20 kHz, which is achieved by using 3-bit dithering.

2.3.1 LED Driver Session

2.3.1.1 Programming

The LP5569 device provides flexibility and programmability for dimming and sequencing control. Each LED can be controlled directly and independently through the serial interface, or LED drivers can be grouped together for preprogrammed flashing patterns. The device has three independent program execution engines. Each engine can control 1 to 9 LED driver outputs, but more than one engine cannot simultaneously control the same LED driver output. Any engine can be used as the master fader for all three engines.

2.3.1.2 Energy Efficiency

An integrated 1x or 1.5x charge pump with adaptive control provides the supply voltage for LEDs when operating with low input voltage. Because the LED drivers are low-side sinks, some or all LEDs can be powered from an external source, if available. The LP5569 device has very low standby current and an automatic power-save mode when the LEDs are inactive.

2.3.1.3 Protection

Protection features include power-on reset, charge-pump input-current limiter, thermal shutdown (TSD), and undervoltage lockout (UVLO).

2.3.1.3.1 Thermal Shutdown (TSD)

The LP5569 device implements a thermal shutdown mechanism to protect the device from damage due to overheating. When the junction temperature rises to 150°C (typical), the device switches into shutdown mode. The LP5569 device releases thermal shutdown when the junction temperature of the device decreases to 130°C (typical).

Thermal shutdown is most often triggered by self-heating, which occurs when there is excessive power dissipation in the device, or insufficient thermal dissipation, or both. The LP5569 power dissipation increases with increased output current and input voltage. When self-heating brings on thermal shutdown, thermal cycling is the typical result. Thermal cycling is the repeating process where the part self-heats, enters thermal shutdown (where internal power dissipation is practically zero), cools, turns on, and then heats up again to the thermal shutdown threshold. Thermal cycling is recognized by a pulsing output voltage and can be stopped by reducing the internal power dissipation (reduce input voltage, or output current, or both) or the ambient temperature. If thermal cycling occurs under the desired operating conditions, thermal dissipation performance must be improved to accommodate the power dissipation of the LP5569 device. The QFN package is designed to have excellent thermal properties that, when soldered to a PCB designed to aid thermal dissipation, allows the LP5569 device to operate under very demanding power-dissipation conditions.

2.3.1.3.2 Undervoltage Lockout (UVLO)

The LP5569 device has an internal comparator that monitors the voltage at VIN. If the input voltage drops to 2.2 V (nominal), undervoltage is detected, the LED outputs and the charge pump shut down, and the corresponding fault bit is set in the fault register. Hysteresis is implemented for the threshold level to avoid continuous triggering of a fault when the threshold is reached. If the input voltage rises above 2.3 V (nominal), the LP5569 device resumes normal operation.

2.3.1.3.3 Power-On Reset (POR)

The LP5569 device has internal comparators that monitor the voltages at VIN and V1P8. When VIN is below 2.2 V or V1P8 is below 1.3 V, reset is active and the LP5569 device is in the DISABLED state.

2.3.1.3.4 LED Fault Detection

The LP5569 device contains both open-LED and shorted-LED fault detection. These fault detections are designed to be used in production-level testing and not normal operation. For the fault flags to operate, they must be enabled via the MISC2 register (address 33h) LED_OPEN_TEST, and LED_SHORT_TEST bits. The fault flags are shared by both open-LED and shorted-LED tests so only one can be enabled at a time. The default LED-fault status is ready in the LED_FAULT1 and LED_FAULT2 registers (addresses 81h and 82h). The following sections detail the proper procedure for reading back open and short faults in the LED strings.

2.3.2 CapTivate™ Touch Session

Capacitive touch sensing MSP430 MCUs are supported by an extensive hardware and software ecosystem with reference designs and code examples to get a design started quickly. Development kits include the MSP-CAPT-FR2633 CapTivate technology development kit. TI also provides free software including the [CapTivate Design Center](#), where engineers can quickly develop applications with an easy-to-use GUI and MSP430Ware™ software, and comprehensive documentation with the [CapTivate™ Technology Guide](#). The TI MSP family of low-power microcontrollers consists of several devices that

feature different sets of peripherals targeted for various applications. The architecture, combined with extensive low-power modes, is optimized to achieve extended battery life in portable measurement applications. The MCU features a powerful 16-bit RISC CPU, 16-bit registers, and constant generators that contribute to maximum code efficiency. The digitally-controlled oscillator (DCO) allows the MCU to wake up from low-power modes to active mode typically in less than 10 μ s.

Figure 2 shows the functional block diagram.

- The MCU has one main power pair of DVCC and DVSS that supplies digital and analog modules. Recommended bypass and decoupling capacitors are 4.7 μ F to 10 μ F and 0.1 μ F, respectively, with \pm 5% accuracy.
- VREG is the decoupling capacitor of the CapTIvate regulator. The recommended value for the required decoupling capacitor is 1 μ F, with a maximum ESR of \leq 200 m Ω .
- P1 and P2 feature the pin interrupt function and can wake the MCU from all LPMs, including LPM3.5 and LPM4.
- Each Timer_A3 has three capture, compare registers. Only CCR1 and CCR2 are externally connected. The CCR0 registers can be used only for internal period timing and interrupt generation.
- In LPM3 or LPM4 mode, the CapTIvate module can be functional while the rest of the peripherals are off.

The CapTIvate module detects the capacitance changed with a charge-transfer method and is functional in AM, LPM0, LPM3, and LPM4. The CapTIvate module can periodically wake the CPU from LPM0, LPM3, or LPM4 based on a CapTIvate timer source such as ACLK or VLO clock. The CapTIvate module can also work on wake-on-touch state machine mode for better power saving without periodically waking up the CPU. The CapTIvate module supports the following touch-sensing capability:

- Up to 16 CapTIvate buttons composed of 2 CapTIvate blocks. Each block consists of 4 I/Os, and these blocks scan in parallel of 2 electrodes.
- Each block can be individually configured in self or mutual mode. Each CapTIvate I/O can be used for either self or mutual electrodes.
- Supports a wake-on-touch state machine.
- Supports synchronized conversion on a zero-crossing event trigger.
- Processing logic to perform filter calculation and threshold detection.

3 Hardware, Software, Testing Requirements, and Test Results

3.1 Required Hardware and Software

3.1.1 Hardware Overview

Figure 3 shows the system overview of the TIDA-01559 design.



Figure 3. TIDA-01559 System Overview

3.1.2 Work Mode Introduction

The TIDA-01559 has three work modes:

- **Proximity mode:** Under this mode, when the hand or anything comes closer than 100 mm, the board uses the breathing effect, and when the hand is removed, the breathing effect disappears.
- **Autonomous Pattern Mode (HMI mode):** Under this mode, the TIDA-01559 works on a different autonomous pattern, breathing (mono-color and mixing-color), chasing (mono-color and mixing-color), two colors chasing in another color base and so on. The *Select* button changes the pattern.
- **Wheel mode (Control mode):** Under this mode, control the LED using clockwise or anticlockwise rotation (put your finger along the dotted line, not on the LED), use the *Select* button to change the color. When demonstrating the “Wheel mode”, do not put anything under the board, because it will influence the sensor.

3.1.3 Firmware

3.1.3.1 Application Firmware Description

The firmware of this reference design runs on the MSP430FR2522IPW16R device, in which a capacitor sensor touch front-end is implemented. The firmware also configures the LP5569 device over I²C to drive the LED pattern. 表 2 lists the system components for the firmware of this reference design.

表 2. TIDA-01559 Firmware System Components

ITEMS	DESCRIPTION
Integrated development environment (IDE)	Code Composer Studio™ v8.0
Target MCU	MSP430FR2522IPW16R
Development kit	MSP CapTivate LaunchPad, MSP430 programmer
MCU to LP5569 connector	P2.1 - EN_PWM
	P1.2 - SDA
	P1.3 - SCL
MCU to LaunchPad connector	TEST - DEBUG
	RESET- DEBUG
	TXD - Tuning for captivate
	RXD - Tuning for captivate

3.1.3.2 Firmware Structure

The TIDA-01559 reference design firmware is based on the TI *CapTivate Software Library*. The *CapTivate Software Library* is a collection of target software components designed to help shorten the development process when working with CapTivate MCUs. The library is provided and supported by Texas Instruments and is delivered with the [CapTivate Design Center](#). The TIDA-01559 adds the touch key user functions and LED driver functions.

図 4 shows the TIDA-01559 firmware structure.



図 4. TIDA-01559 Firmware Structure

In the user application, three different user modes are defined:

1. **Demo mode:** Shows the different LED patterns including breathing, ring chasing, door open, color chasing, and so forth.
2. **Proxy mode:** The proxy sensor wakes up the LED when it detects a human approaching. After awakening, the LED continues breathing until there is no human detection.
3. **Wheel mode:** The user touches the wheel sensor, then the LED turns on following the touch.

3.1.3.3 User Application Flowcharts

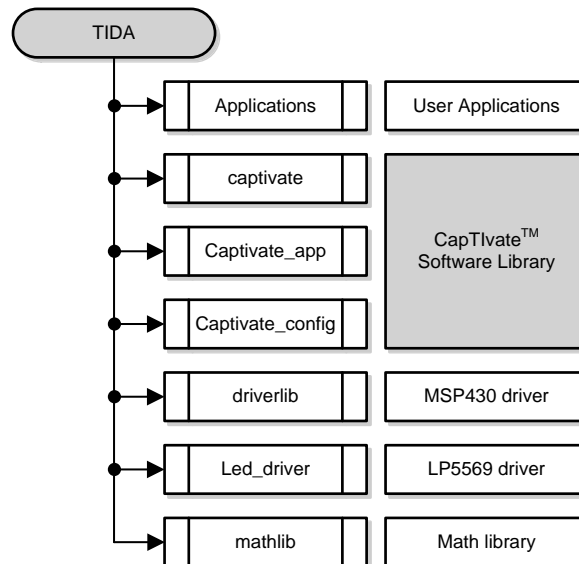
Button Event: This event is generated by the CapTIvate software (see 図 5). The event handle is to change the running mode by touching a different button.



図 5. Button Event Flowchart

Proxy Event: This event is generated by the CapTIvate software library (see 図 6). When the sensor is on, the LED begins breathing. When sensor detection is off, the LED is closed after 150 ms.

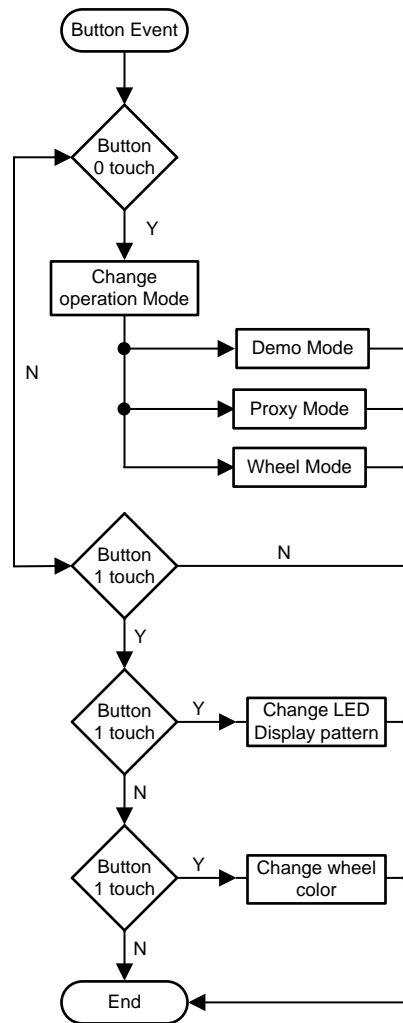

図 6. Proxy Event Flowchart

Wheel Event: This event is generated by the CapTIvate software (see 図 7). When the user touches the wheel sensor, the handler reads the wheel position from the CapTIvate software and turns on the corresponding LED.

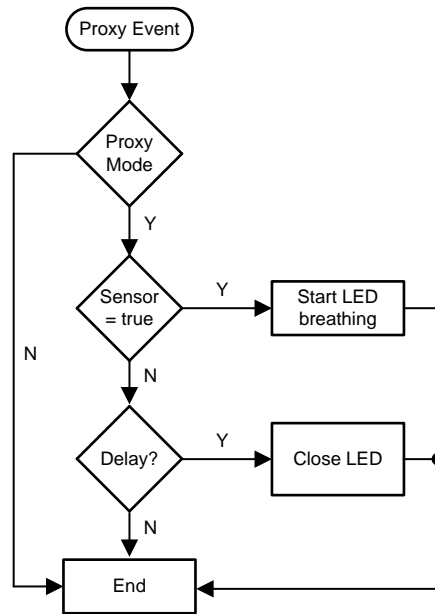

図 7. Wheel Event Flowchart

3.1.3.3.1 Service Functions for the LP5569 Device

☒ 8 shows the close LED flowchart. This flow shows the *Stop all engines* function in the LP5569 device and turns off the LEDs.

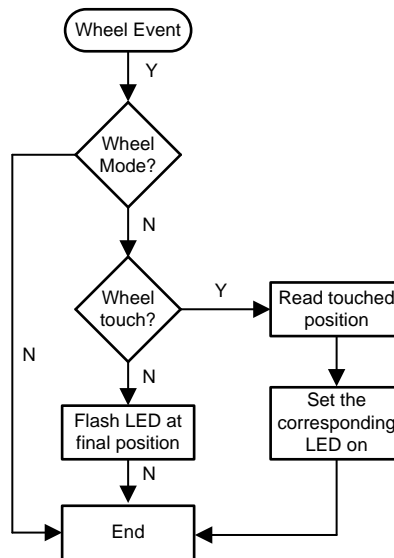
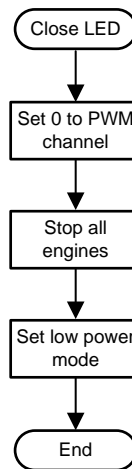

☒ 8. Close LED Flowchart

☒ 9 shows the load SRAM flowchart and where the LED engines are changed.

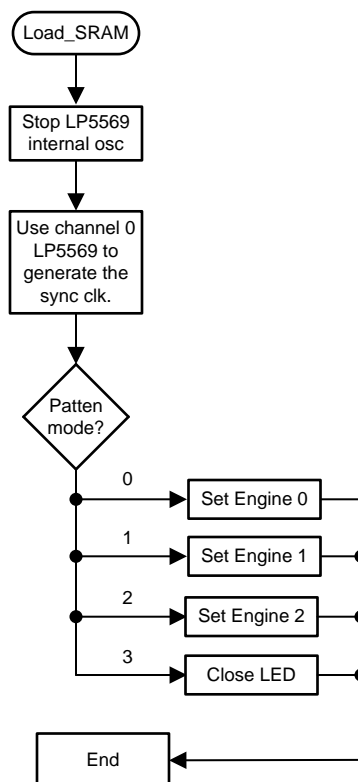

☒ 9. Load SRAM Flowchart

Figure 10 illustrates the overall state machine.

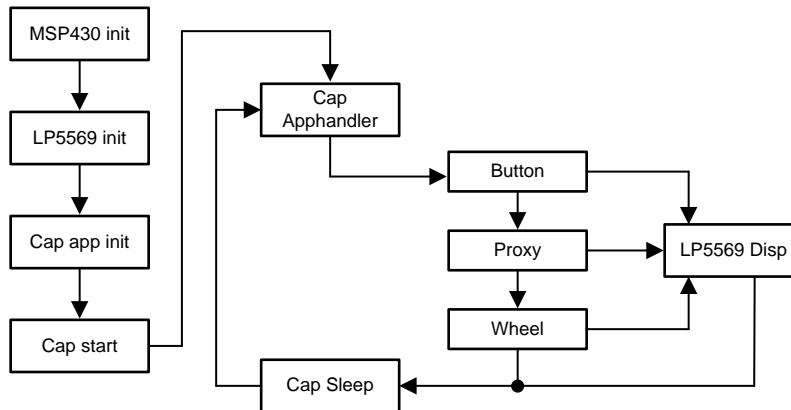

Figure 10. TIDA-01559 Overall State Machine

3.1.3.4 How to Integrate the TI CapTIvate™ IP Into a Design

The *CapTIvate Software Library* is a collection of target software components designed to help shorten the development process when working with CapTIvate MCUs. The library is provided and supported by Texas Instruments and is delivered with the CapTIvate Design Center.

The library provides the following features:

- Hardware abstraction of the CapTIvate peripheral features
- Processing of button, slider, wheel, and proximity sensors with simple callback reporting when measurement and processing are complete
- User interface management to enable a simple top level API that is easy to use
- Electromagnetic compatibility features for improving noise immunity
- Communications infrastructure for connecting a CapTIvate MCU to the *CapTIvate Design Center* during tuning or to a host processor in an application

These features provide the following main benefits:

- Simplification of sensor configuration, measurement, processing, and data communication
- Faster application development cycles
- Seamless integration with the *CapTIvate Design Center* development GUI
- Reduced code footprint on devices with CapTIvate software in ROM

The library was designed and organized for capacitive user interface applications. However, it may also be used for other applications that require the ability to measure relative changes in capacitance.

3.1.3.4.1 How-To in the CapTIvate Software Library

The how-to section of the CapTIvate Software Library chapter contains basic code snippets that demonstrate how to perform simple tasks, such as measuring a sensor, checking the status of a sensor, or accessing raw data.

3.1.3.4.1.1 Use the Top-Level API

The top level API of the CapTlvate Software Library provides a simple, highly-abstract programming interface to the library. To get an application up and running, it is only necessary to have knowledge of three basic functions: CAPT_initUI(), CAPT_calibrateUI(), and CAPT_updateUI().

3.1.3.4.1.2 Scope

As introduced in the programming model section, the top-level API functions operate solely on the top level application object, or tCaptivateApplication. This object contains all of the information that is needed to run the user interface. It contains the links to all of the sensors that are in the UI. It is important to understand that when a top-level API function is used, all of the sensors that are associated with the application are affected. For example, calling CAPT_calibrateUI() causes each sensor in the UI to be calibrated.

3.1.3.4.1.3 Open Source

The top-level API functions are delivered as open source functions in the library, so that the software designer can understand how the functions work. The functions exist in the CAPT_Manager.c and CAPT_Manager.h files, which are a part of the ADVANCED module of the library.

3.1.3.4.1.4 Setting up an Application

When setting up an application, it is important to note that there are two types of functions in the top-level API:

1. Initialization functions (run one time at start-up)
2. Periodic functions (called periodically to do something while the application is running)

The initialization functions are CAPT_initUI() and CAPT_calibrateUI(). CAPT_updateUI() is a periodic function. The initialization functions must be called at the beginning of the application.

For additional details, see [Getting Started With MSP MCUs With CapTlvate™ Technology](#).

3.1.3.5 How to Define the LP5569 Pattern

The LP5569 device is a programmable, easy-to-use 9-channel I2C LED driver designed to produce lighting effects for various applications. The LED driver is equipped with an internal SRAM memory for user-programmed sequences and three programmable LED engines, which allow operation without processor control. Autonomous operation reduces system power consumption when the processor is put in sleep mode.

As an example for a breathing pattern, all LEDs fade in and out as the same color at the same rate, therefore all devices should run the same engine code (see [Figure 11](#)).

```

.segment          program1      ;Program for engine 1.
loop1_0:
  map_start      row1          ;Map the first LED.
  load_end       row7          ;End address of the mapping data table.
loop1:
  ramp           2, 200        ;Increase PWM 0->78% in 2 second.
  ramp           2, -255       ;Decrease PWM ->0% in 2 seconds.
  wait           0.4           ;Wait for 0.4 seconds.
  ramp           2, 200        ;Increase PWM 0->78% in 2 second.
  ramp           2, -255       ;Decrease PWM ->0% in 2 seconds.
  wait           0.4           ;Wait for 0.4 seconds.
  map_next
  branch         6,loop1       ;Loop 6 time
  map_addr       row8
  ramp           1.5, 200      ;Increase PWM 0->78% in 1.5 second.
  wait           0.4           ;Wait for 0.4 seconds.
  wait           0.4           ;Wait for 0.4 seconds.
  map_addr       row9
  ramp           3, 200        ;Increase PWM 0->78% in 3 second.
  ramp           3, -255       ;Decrease PWM ->0% in 3 seconds.
  ramp           3, 200        ;Increase PWM 0->78% in 3 second.
  ramp           3, -255       ;Decrease PWM ->0% in 3 seconds.
  map_addr       row8
  ramp           1.5, -255     ;Decrease PWM ->0% in 1.5 seconds.

```

Figure 11. Breathing Pattern Code

For more information, see [LP5569 Lighting Pattern Design](#)

3.2 Testing and Results

3.2.1 How to Run This Demonstration

- I. For a TIDA-01559 demonstration, only one TIDA-01559 board and one USB cable is needed. Before demonstrating, power the board using a USB port.
- II. When powered by USB port, the board will work on HMI mode default, the pattern can be changed by pressing the *Select* button, and there are three different patterns preset.
- III. Press the *Mode* button once, the work mode changes to Wheel mode, you can use your finger to control the LED along with the dot line. Press the *Select* button to change the color.
- IV. Press the *Mode* button again, the work mode changes to Proximity mode. In this mode, when your hand or anything comes within 100 mm of the board, the LED works in breathing effect, remove your hand and the breathing effect stops.
- V. Press the *Mode* button, and the work mode goes back to HMI mode.

3.2.2 Test Results

The test includes the standby power, MCU work loading.

3.2.2.1 MCU Work Loading With LP5569

One key feature of the LP5569 device is LED engine control. An LED driver without engine control requires the MCU to be active for each register data transfer. With the engine control, pre-set patterns are stored in program memory, so the LED driver can run a blinking or color pattern autonomously, allowing the MCU to sleep, thus saving the standby power and off-loads from the MCU.

The LP5569 device has four LED engine variables which are divided into local and global variables. Variables A and B are engine-specific local variables and each of the three engines has separate A and B variables, so there is a total of six A and B variables. Variable A can be read and written via I²C registers 42h–44h. Local variable B is not available via I²C and can only be accessed by the LED engine. Variables C and D are global variables which are shared by all three LED engines. Global variable C is not available via I²C and can only be accessed by the LED engines. The D variable can be read and written via I²C register 3Eh. Variables are referenced to instructions with 2 bits.

Figure 12 is the MCU work loading without LP5569. This picture shows that without the LED engine, the MCU work loading is near to 20%. It will be decided by complex pattern, but if the LP5569 with LED engine control is used, the MCU work loading is near to 0% after uploading the code to Engine control from the MCU.

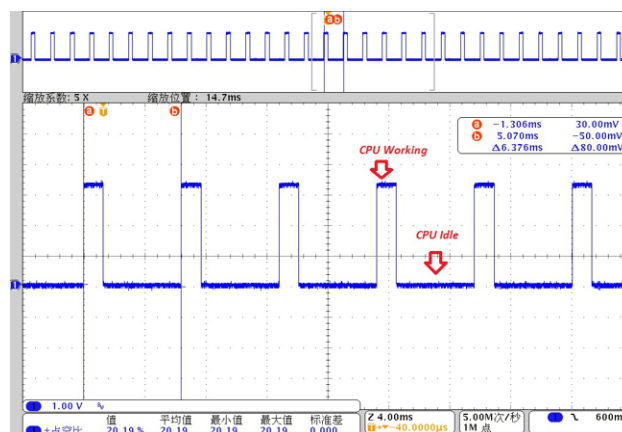

Figure 12. MCU Work Loading Without LP5569

3.2.2.2 Standby Power

The MSP430FR2522 MCU was used in this design. The MSP430FR2522 is an ultra-low-power MSP430™ microcontroller for capacitive touch sensing that features CapTIvate touch technology for buttons and proximity applications. MSP430 MCUs with CapTIvate technology provide the most integrated and autonomous capacitive-touch solution in the market with high reliability and noise immunity at the lowest power. TI's capacitive touch technology supports concurrent self-capacitance and mutual-capacitance electrodes on the same design for maximum flexibility. MSP430 MCUs with CapTIvate technology operate through thick glass, plastic enclosures, metal, and wood with operation in harsh environments including wet, greasy, and dirty environments.

With the MSP430FR2522 very low standby power consumption is achieved., [表 3](#) lists the power consumption of the MSP430FR2522, LP5569, and LDO. This table shows that under LPM0 mode (CPU idle), the standby current of the MSP430FR2522 is 430 μA , and under LPM4 mode (Deep sleep), the standby current of the MSP430FR2522 is only 2.5 μA .

表 3. TIDA-01559 Standby Power Consumption

	Work Mode		Unit
MCU	LPM0 (CPU idle)	430	μA
	LPM4 (Deep sleep)	2.5	μA
LDO (3.3 V)	TLV743333PDBVR	47	μA
LDO (1.8 V)	TLV743318PDBVR	180	μA
LED	LP5569 \times 4	70	μA

4 Design Files

4.1 Schematics

To download the schematics, see the design files at [TIDA-01559](#).

4.2 Bill of Materials

To download the bill of materials (BOM), see the design files at [TIDA-01559](#).

4.3 PCB Layout Recommendations

Follow this list for proper PCB layout:

1. Use proper grounding and short traces for the external crystal to reduce parasitic capacitance.
2. Incorporate proper bypass capacitors on DVCC and reference pins, if used.
3. Avoid routing any high-frequency signal close to an analog signal line. For example, keep digital switching signals such as PWM or JTAG signals away from the oscillator circuit.
4. Use proper ESD level protection to protect the device from unintended high-voltage electrostatic discharge.

4.3.1 Layout Prints

To download the layer plots, see the design files at [TIDA-01559](#).

4.4 Altium Project

To download the Altium project files, see the design files at [TIDA-01559](#).

4.5 Gerber Files

To download the Gerber files, see the design files at [TIDA-01559](#).

4.6 Assembly Drawings

To download the assembly drawings, see the design files at [TIDA-01559](#).

5 Software Files

To download the software files, see the design files at [TIDA-01559](#).

6 Related Documentation

1. [LP5569 Nine-Channel I2C RGB LED Driver With Engine Control and Charge Pump Data Sheet](#)
2. [MSP430FR25x2 Capacitive Touch Sensing Mixed-Signal Microcontrollers Data Sheet](#)

6.1 Trademarks

E2E, CapTIvate, MSP430, BoosterPack, LaunchPad, MSP430Ware, Code Composer Studio are trademarks of Texas Instruments.

7 About the Authors

YUAN (JASON) TAO is a systems engineer at Texas Instruments, where he is responsible for developing reference design solutions for the industrial segment. Yuan brings to this role his extensive experience in power electronics, high-frequency DC/DC, AC/DC converters, and analog circuit design. Yuan earned his master of IC design and manufacture from Shanghai Jiao Tong University in 2007.

Fan (Hawken) Li is a systems engineer at Texas Instruments, where he is responsible for developing reference design solutions for the industrial segment. Hawken brings to this role his extensive experience in home appliances, including motor driver, EP, analog circuit design, and so forth.

TIの設計情報およびリソースに関する重要な注意事項

Texas Instruments Incorporated ("TI")の技術、アプリケーションその他設計に関する助言、サービスまたは情報は、TI製品を組み込んだアプリケーションを開発する設計者に役立つことを目的として提供するものです。これにはリファレンス設計や、評価モジュールに関係する資料が含まれますが、これらに限られません。以下、これらを総称して「TIリソース」と呼びます。いかなる方法であっても、TIリソースのいずれかをダウンロード、アクセス、または使用した場合、お客様(個人、または会社を代表している場合にはお客様の会社)は、これらのリソースをここに記載された目的にのみ使用し、この注意事項の条項に従うことに合意したものとします。

TIによるTIリソースの提供は、TI製品に対する該当の発行済み保証事項または免責事項を拡張またはいかなる形でも変更するものではなく、これらのTIリソースを提供することによって、TIにはいかなる追加義務も責任も発生しないものとします。TIは、自社のTIリソースに訂正、拡張、改良、およびその他の変更を加える権利を留保します。

お客様は、自らのアプリケーションの設計において、ご自身が独自に分析、評価、判断を行う責任がお客様にあり、お客様のアプリケーション(および、お客様のアプリケーションに使用されるすべてのTI製品)の安全性、および該当するすべての規制、法、その他適用される要件への遵守を保証するすべての責任をお客様のみが負うことを理解し、合意するものとします。お客様は、自身のアプリケーションに関して、(1) 故障による危険な結果を予測し、(2) 障害とその結果を監視し、および、(3) 損害を引き起こす障害の可能性を減らし、適切な対策を行う目的での、安全策を開発し実装するために必要な、すべての技術を保持していることを表明するものとします。お客様は、TI製品を含むアプリケーションを使用または配布する前に、それらのアプリケーション、およびアプリケーションに使用されているTI製品の機能性を完全にテストすることに合意するものとします。TIは、特定のTIリソース用に発行されたドキュメントで明示的に記載されているもの以外のテストを実行していません。

お客様は、個別のTIリソースにつき、当該TIリソースに記載されているTI製品を含むアプリケーションの開発に関連する目的でのみ、使用、コピー、変更することが許可されています。明示的または黙示的を問わず、禁反言の法理その他どのような理由でも、他のTIの知的所有権に対するその他のライセンスは付与されません。また、TIまたは他のいかなる第三者のテクノロジーまたは知的所有権についても、いかなるライセンスも付与されるものではありません。付与されないものには、TI製品またはサービスが使用される組み合わせ、機械、プロセスに関連する特許権、著作権、回路配置利用権、その他の知的所有権が含まれますが、これらに限られません。第三者の製品やサービスに関する、またはそれらを参照する情報は、そのような製品またはサービスを利用するライセンスを構成するものではなく、それらに対する保証または推奨を意味するものでもありません。TIリソースを使用するため、第三者の特許または他の知的所有権に基づく第三者からのライセンス、もしくは、TIの特許または他の知的所有権に基づくTIからのライセンスが必要な場合があります。

TIのリソースは、それに含まれるあらゆる欠陥も含めて、「現状のまま」提供されます。TIは、TIリソースまたはその仕様に関して、明示的か暗黙的にかかわらず、他のいかなる保証または表明も行いません。これには、正確性または完全性、権原、続発性の障害に関する保証、および商品性、特定目的への適合性、第三者の知的所有権の非侵害に対する黙示的保証が含まれますが、これらに限られません。

TIは、いかなる苦情に対しても、お客様への弁済または補償を行う義務はなく、行わないものとします。これには、任意の製品の組み合わせに関連する、またはそれらに基づく侵害の請求も含まれますが、これらに限られず、またその事実についてTIリソースまたは他の場所に記載されているか否かを問わないものとします。いかなる場合も、TIリソースまたはその使用に関連して、またはそれらにより発生した、実際の、直接的、特別、付随的、間接的、懲罰的、偶発的、または、結果的な損害について、そのような損害の可能性についてTIが知らされていたかどうかにかかわらず、TIは責任を負わないものとします。

お客様は、この注意事項の条件および条項に従わなかったために発生した、いかなる損害、コスト、損失、責任からも、TIおよびその代表者を完全に免責するものとします。

この注意事項はTIリソースに適用されます。特定の種類の資料、TI製品、およびサービスの使用および購入については、追加条項が適用されます。これには、半導体製品(<http://www.ti.com/sc/docs/stdterms.htm>)、評価モジュール、およびサンプル(<http://www.ti.com/sc/docs/sampterms.htm>)についてのTIの標準条項が含まれますが、これらに限られません。