

TPS7H3301-SP シンクおよびソース耐放射線 3A DDR ターミネーションレギュレータ、VTTREF バッファ内蔵

1 特長

- **5962R14228 (1):**
 - 総吸収線量 (TID) 100krad(Si) までの放射線耐性保証 (RHA) 認定
 - シングル イベント ラッチアップ (SEL)、シングル イベント ゲート ラブチャージャー (SEGR)、シングル イベント バーンアウト (SEB) の耐性: LET = 70MeV-cm²/mg⁽²⁾ まで
 - シングル イベント 過渡 (SET)、シングル イベント 機能割り込み (SEFI)、シングル イベント アップセット (SEU) の耐性: 70MeV-cm²/mg⁽²⁾ まで
- DDR、DDR2、DDR3、DDR3L、DDR4 終端アプリケーションをサポート
- 入力電圧: 2.5V レールと 3.3V レールをサポート(3)
- 0.9V まで引き下げられた独立した低電圧入力 (VLDOIN) により電力効率が向上(3)
- 3A シンク / ソース終端レギュレータにドループ補償を搭載
- イネーブル入力とパワーグッド出力による電源シーケンス
- VTT ターミネーションレギュレータ
 - 出力電圧範囲: 0.5~1.75 V
 - 3A のシンクおよびソース電流
- センス入力を備えた高精度分圧回路を内蔵
- リモートセンシング (VTTSENS)
- VTTREF バッファ付きリファレンス
 - VDDQSNS に対する 49%~51% の精度 (±3mA)
 - ±10mA のシンクおよびソース電流
- 低電圧誤動作防止 (UVLO)、過電流制限 (OCL) 機能を内蔵

2 アプリケーション

- コマンドとデータの処理 (C&DH)
- 光学画像処理ペイロード
- レーダー画像処理ペイロード

3 概要

TPS7H3301-SP は、TID および SEE 耐放射線性のダブルデータレート (DDR) 3A ターミネーションレギュレータで、VTTREF バッファが内蔵されています。このレギュレータは、シングルボードコンピュータ、ソリッドステートレコーダ、ペイロード処理などの宇宙向け DDR 終端アプリケーション用に、包括的でコンパクトな低ノイズソリューションを提供するように特化して設計されています。

TPS7H3301-SP は DDR、DDR2、DDR3、DDR4 を使用する DDR VTT 終端アプリケーションをサポートしています。TPS7H3301-SP VTT レギュレータの高速過度応答により、読み取り / 書き込み状態で非常に安定した電源を実現できます。遷移中、VTTREF 電源の高速トラック機能により、VTT/V_O と VTTREF の間の電圧オフセットが最小化されます。シンプルな電源シーケンスを実現するために、TPS7H3301-SP にはイネーブル入力とパワーグッド出力 (PGOOD) の両方が内蔵されています。PGOOD 出力はオープンドレインであるため、複数のオープンドレイン出力に接続して、すべての電源がレギュレーションに入ったことを監視できます。イネーブル信号を使用して、RAM (S3) パワーダウンモードへのサスペンド中に VTT/V_O を放電することもできます。

製品情報 (1)

部品番号 (3)	グレード	パッケージ
5962R1422801VXC(2)	フライトグレード RHA 100krad(Si)	16 ピン CFP
5962-1422801VXC(2)	フライトグレード QMLV	9.6mm × 11.00mm 重量: 1.55g ⁽⁵⁾
TPS7H3301HKR/EM	エンジニアリングモジュール ⁽⁴⁾	
TPS7H3301EVM-CVAL	セラミック評価ボード	EVM

- (1) 利用可能なすべてのパッケージについては、データシートの末尾にある注文情報を参照してください。
- (2) 詳細については、『放射線レポート』を参照してください。
- (3) DDR2、DDR3、DDR3L、DDR4 に適用されます。DDR の場合、入力電圧 = 3.3V (公称)。DDR1 では V_{IN} は 2.95~3.5V、すべての DDR で V_{LDOIN} > V_{TT/V_O} です。DDR2 3A 負荷条件の場合、V_{IN} は 2.45~3.5V です。V_{IN} ヘッドルーム: V_{IN_MIN} ≥ V_{TT/V_O} + 1.5V。
- (4) これらのユニットは、技術的な評価のみを目的としています。標準とは異なるフロー (バーンインがないなど) に従って処理されており、25°C の温度定格のみがテストされています。これらのユニットは、認定、量産、放射線テスト、航空での使用には適していません。部品は、MIL に規定されている温度範囲全体 (-55°C~125°C) にわたる性能も動作寿命全体にわたる性能も保証されていません。
- (5) 重量の精度は ±10% です。

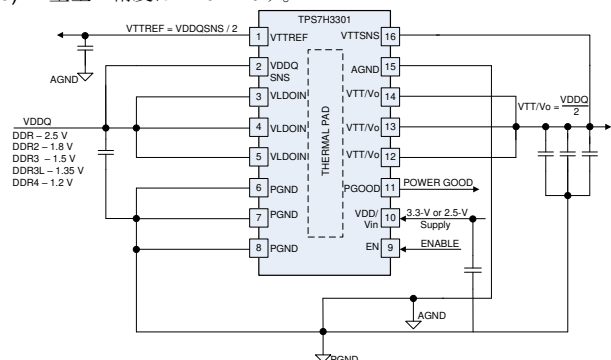

標準の DDR アプリケーション



Table of Contents

1 特長.....	1	7.4 Device Functional Modes.....	15
2 アプリケーション.....	1	8 Application and Implementation.....	16
3 概要.....	1	8.1 Application Information.....	16
4 Revision History.....	2	8.2 Typical Application.....	16
5 Pin Configuration and Functions.....	4	9 Layout.....	25
6 Specifications.....	5	9.1 Layout Guidelines.....	25
6.1 Absolute Maximum Ratings.....	5	9.2 Layout Example.....	25
6.2 ESD Ratings.....	5	9.3 Thermal Considerations.....	26
6.3 Recommended Operating Conditions.....	6	10 Device and Documentation Support.....	27
6.4 Thermal Information.....	6	10.1 Device Support.....	27
6.5 Electrical Characteristics.....	7	10.2 Documentation Support.....	27
6.6 Typical Characteristics.....	10	10.3 ドキュメントの更新通知を受け取る方法.....	27
7 Detailed Description.....	13	10.4 サポート・リソース.....	27
7.1 Overview.....	13	10.5 Trademarks.....	27
7.2 Functional Block Diagram.....	13	10.6 静電気放電に関する注意事項.....	27
7.3 Feature Description.....	13	10.7 用語集.....	27

4 Revision History

資料番号末尾の英字は改訂を表しています。その改訂履歴は英語版に準じています。

Changes from Revision B (June 2020) to Revision C (September 2024)	Page
ドキュメント全体にわたって表、図、相互参照の採番方法を更新.....	1
Electrical characteristics are tested in ambient conditions of -55°C to 125°C, previous reference to T_J is updated to T_A	7
VTTSENS test condition to show -5mA test condition and updated limits; additional VTTSENS test conditions and limits at 5mA and -1A to 1A.....	7
Clarified specification name VLDOIN-VTT/ V_O to V_{DO} , removed Note1.....	7
Production testing coverage for V_{DO} (VLDOIN-VTT/ V_O) implemented across temperature, Note 2 has been removed for test conditions previously appended with Note 2.....	7
Updated I_{VOSRCL} limits and test conditions for I_{VOSRCL} and I_{VOSNCL}	7
Production testing coverage of R_{DSCHRG} implemented across temperature.....	7
Clarified test condition description for $V_{TH(PG)}$	7
Removed VDDQSNS voltage range from Electrical Characteristics table as this is contained in the Recommended Operating Conditions table.....	7
Updated V_{VTTREF} name to $V_{VTTREF(load_reg)}$ and added new accuracy spec, $V_{VTTREFaccuracy}$	7
Clarified test conditions for $I_{VTTREFSRCL}$ & $I_{VTTREFSNCL}$	7
$V_{VINUVIN}$ tested across temperature.....	7
I_{ENLEAK} tested across temperature.....	7
Removed Note for T_{SON} , note is redundant for typical specifications.....	7
Revised reference to 100kΩ pull-up resistor.....	14
Updated power dissipation calculation for VDD/V_{IN} and VLDOIN.....	26

Changes from Revision A (June 2016) to Revision B (June 2020)	Page
DLA 図番号を変更.....	1
「特長」の耐放射線性能のまとめを変更.....	1
サポートされている DDR 終端アプリケーションの機能説明を変更.....	1
特長で VTTREF 精度を変更.....	1
サポートされている DDR アプリケーションの説明を変更.....	1

- 「製品情報」の表にパッケージ重量を追加..... 1
- Changed pin name references throughout document to be consistent 4
- Added additional thermal metrics..... 6
- Added clarification of T_J temperature range in *Electrical Characteristics* table..... 7
- Changed ambiguous tolerance specification for V_{TT}/V_O to explicitly specify min/max range..... 7
- Changed UVLO threshold hysteresis to own table entry 7
- Changed naming on VTTREF plots for consistency 10
- Added ceramic to capacitor description to meet stability requirements..... 14
- Added correct cross reference for output current limit..... 14
- Changed wording for clarity for V_{IN}/V_{DD} 17
- Changed comment to reflect total ESR 17
- JEDEC specification references 19
- Changed to improved transient plot and description..... 19
- Added or smaller for layout thermal via size 25
- Changed to improved recommended layout diagram. 25

5 Pin Configuration and Functions



図 5-1. HKR Package, 16-Pin CFP (Top View)

表 5-1. Pin Functions

PIN		I/O	DESCRIPTION
NAME	NO.		
VTTREF	1	O	Reference output. Connect to GND through 0.1- μ F ceramic capacitor.
VDDQSNS	2	I	VDDQ sense input. Reference input for VTTREF.
VLDOIN	3	I	Supply voltage for the LDO. Connect to VDDQ voltage or an alternate voltage source.
	4		
	5		
PGND	6	—	Power ground. Connect output for the VTT/V _O LDO to negative pin of the output capacitor.
	7		
	8		
EN	9	I	Enable pin. Driving this pin to logic high enables the device; driving this pin to logic low disables the device.
VDD/V _{IN}	10	I	2.5- or 3.3-V power supply. A ceramic decoupling capacitor with a value between 1 and 10 μ F is required.
PGOOD	11	O	PGOOD output pin. PGOOD pin is an open drain output to indicate the output voltage is within specification.
	12		
	13		
VTT/V _O	14	O	Power output for VTT/V _O LDO.
	15		
AGND	15	—	Signal ground. Connect to negative pin of output capacitors. ⁽¹⁾
VTTSNS	16	I	Voltage sense for VTT/V _O . Connect to positive pin of the output capacitor or the load.

(1) Thermal pad and package lid are internally connected to ground.

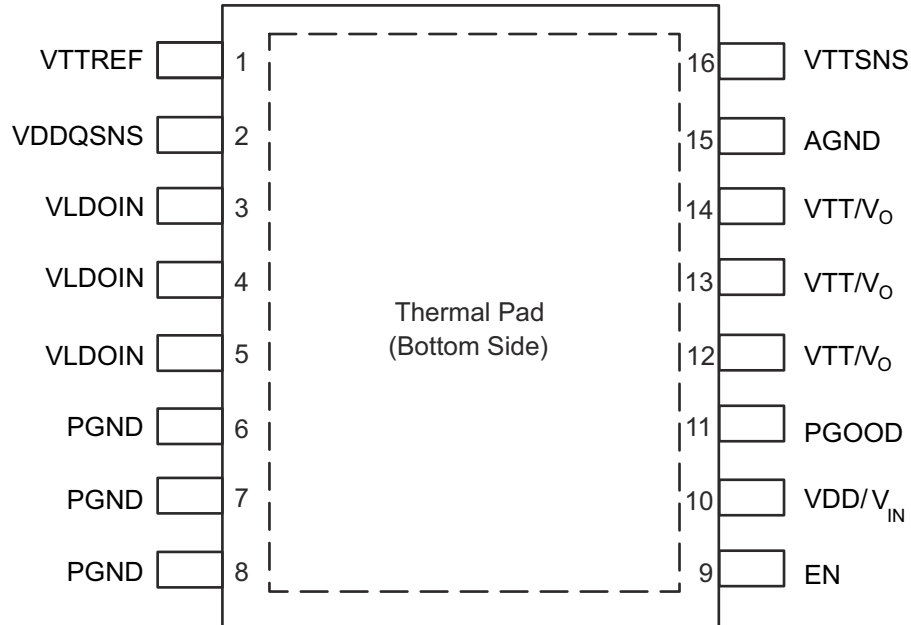
6 Specifications

6.1 Absolute Maximum Ratings

over operating temperature, unless otherwise noted⁽¹⁾

		MIN	MAX	UNIT
Input voltage ⁽²⁾	VDD/V _{IN} , VLDOIN, VTTSNS, VDDQSNS	-0.36	3.6	V
	EN	-0.3	3.6	
	PGND to AGND	-0.3	0.3	
Output voltage ⁽²⁾	VTT/V _O , VTTREF	-0.3	3.6	V
	PGOOD	-0.3	3.6	
T _J	Operating junction temperature	-55	150	°C
T _{stg}	Storage temperature	-55	150	°C

(1) Stresses beyond those listed under *Absolute Maximum Ratings* may cause permanent damage to the device. These are stress ratings only and functional operation of the device at these or any other conditions beyond those indicated under *Recommended Operating Conditions* is not implied. Exposure to absolute-maximum-rated conditions for extended periods may affect device reliability.

(2) All voltage values are with respect to the network ground (AGND) pin unless otherwise noted.

6.2 ESD Ratings

		VALUE	UNIT
V _(ESD)	Electrostatic discharge		
	Human-body model (HBM), per ANSI/ESDA/JEDEC JS-001, all pins ⁽¹⁾	±4000	V
Charged-device model (CDM), per JEDEC specification JESD22-C101, all pins ⁽²⁾	±750		

(1) JEDEC document JEP155 states that 500-V HBM allows safe manufacturing with a standard ESD control process.

(2) JEDEC document JEP157 states that 250-V CDM allows safe manufacturing with a standard ESD control process.

6.3 Recommended Operating Conditions

All voltage values are with respect to the network ground (AGND) pin unless otherwise noted

		MIN	NOM	MAX	UNIT
Supply voltage	VDD/V _{IN}	2.375		3.5	V
Voltage	VLDOIN	0.9		3.5	V
	EN, VTTSNS	-0.1		3.5	
	VDDQSNS	1		3.5	
	VTT/V _O , PGOOD	-0.1		3.5	
	VTTREF	-0.1		1.8	
	PGND	-0.1		0.1	
T _J	Operating junction temperature	-55		125	°C

6.4 Thermal Information

THERMAL METRIC ^{(2) (1) (3)}		TPS7H3301-SP		UNIT
		HKR (CFP)		
		16 PINS		
R _{θJA}	Junction-to-ambient thermal resistance	24.6		°C/W
R _{θJC(top)}	Junction-to-case (top) thermal resistance	5.8		°C/W
R _{θJB}	Junction-to-board thermal resistance	8.4		°C/W
ψ _{JT}	Junction-to-top characterization parameter	1.6		°C/W
ψ _{JB}	Junction-to-board characterization parameter	8.4		°C/W
R _{θJC(bot)}	Junction-to-case (bottom) thermal resistance	0.54		°C/W

- (1) Do not allow package body temperature to exceed 265°C at any time or permanent damage may result.
- (2) For more information about traditional and new thermal metrics, see the *Semiconductor and IC Package Thermal Metrics* application report, [SPRA953](#).
- (3) Maximum power dissipation may be limited by overcurrent protection.

6.5 Electrical Characteristics

Over full temperature range, $T_A = -55^\circ\text{C}$ to 125°C , $V_{DD}/V_{IN} = 3.3\text{ V}$ and 2.375 V (for $V_{DD}/V_{IN} > V_{LDOIN}$), $V_{LDOIN} = 1.8\text{ V}$, $V_{DDQSNS} = 1.8\text{ V}$, $V_{TTSNS} = 0.9\text{ V}$, $EN = V_{DD}/V_{IN}$, 標準の DDR アプリケーション unless otherwise noted. All voltage values are with respect to the network ground (AGND) pin unless otherwise noted.

PARAMETER		TEST CONDITIONS	MIN	TYP	MAX	UNIT	
SUPPLY CURRENT							
$I_{VDD/Vin}$	Supply current	$EN = 3.3\text{ V}$, no load		18	30	mA	
$I_{VDD(SDN)}$	Shutdown current	$EN = 0\text{ V}$, $V_{DDQSNS} = 0$, no load		3	5	mA	
		$EN = 0\text{ V}$, $V_{DDQSNS} > 0.78\text{ V}$, no load		6.5	8		
I_{VLDOIN}	Supply current of VLDOIN	$EN = 3.3\text{ V}$, no load		575	1200	μA	
$I_{VLDOIN(SDN)}$	Shutdown current of VLDOIN	$EN = 0\text{ V}$, no load		50	100	μA	
INPUT CURRENT							
$I_{VDDQSNS}$	Input current, VDDQSNS	$EN = 3.3\text{ V}$		4	6	μA	
V_{TT}/V_O OUTPUT							
V_{TTSNS}	Output DC voltage, V_{TT}/V_O	$I_{VTT} = 5\text{ mA}$	VDDQSNS = VLDOIN 2.5 V (DDR1)	1.219	1.25	1.276	V
			VDDQSNS = VLDOIN 1.8 V (DDR2)	0.889	0.9	0.921	
			VDDQSNS = VLDOIN 1.5 V (DDR3)	0.743	0.75	0.769	
			VDDQSNS = VLDOIN 1.35 V (DDR3L)	0.668	0.67	0.691	
			VDDQSNS = VLDOIN 1.2 V (DDR4)	0.593	0.6	0.617	
		$I_{VTT} = -5\text{ mA}$	VDDQSNS = VLDOIN 2.5 V (DDR1)	1.22	1.25	1.272	V
			VDDQSNS = VLDOIN 1.8 V (DDR2)	0.89	0.9	0.923	
			VDDQSNS = VLDOIN 1.5 V (DDR3)	0.744	0.75	0.767	
			VDDQSNS = VLDOIN 1.35 V (DDR3L)	0.669	0.675	0.691	
		$-1\text{ A} \leq I_{VTT} \leq 1\text{ A}$	VDDQSNS = VLDOIN 2.5 V (DDR1)	1.219	1.26	1.301	V
			VDDQSNS = VLDOIN 1.8 V (DDR2)	0.879	0.91	0.933	
			VDDQSNS = VLDOIN 1.5 V (DDR3)	0.734	0.76	0.781	
			VDDQSNS = VLDOIN 1.35 V (DDR3L)	0.655	0.69	0.708	
			VDDQSNS = VLDOIN 1.2 V (DDR4)	0.58	0.6	0.633	
		V_{DO}	Dropout voltage, $V_{DO} = V_{LDOIN} - V_{TTSNS}$. V_{DO} recorded when $V_{TTSNS} - V_{TT} = 50\text{ mV}$	VDDQSNS = 2.5 V (DDR1)	$I_{VTT} = 0.5\text{ A}$		50
$I_{VTT} = 1\text{ A}$					101	300	
$I_{VTT} = 2\text{ A}$					209	400	
VDDQSNS = 1.8 V (DDR2)	$I_{VTT} = 0.5\text{ A}$				54	230	
	$I_{VTT} = 1\text{ A}$				108	300	
	$I_{VTT} = 2\text{ A}$				228	400	
VDDQSNS = 1.5 V (DDR3)	$I_{VTT} = 0.5\text{ A}$				52	230	
	$I_{VTT} = 1\text{ A}$				104	300	
	$I_{VTT} = 2\text{ A}$				216	400	
VDDQSNS = 1.35 V (DDR3)	$I_{VTT} = 0.5\text{ A}$				50	230	
	$I_{VTT} = 1\text{ A}$				102	300	
	$I_{VTT} = 2\text{ A}$				212	400	
VDDQSNS = 1.2 V (DDR4)	$I_{VTT} = 0.5\text{ A}$		50	230			
	$I_{VTT} = 1\text{ A}$		102	300			
	$I_{VTT} = 2\text{ A}$		210	400			

6.5 Electrical Characteristics (続き)

Over full temperature range, $T_A = -55^\circ\text{C}$ to 125°C , $V_{DD}/V_{IN} = 3.3\text{ V}$ and 2.375 V (for $V_{DD}/V_{IN} > V_{LDOIN}$), $V_{LDOIN} = 1.8\text{ V}$, $V_{DDQSNS} = 1.8\text{ V}$, $V_{TTSNS} = 0.9\text{ V}$, $EN = V_{DD}/V_{IN}$, 標準のDDRアプリケーション unless otherwise noted. All voltage values are with respect to the network ground (AGND) pin unless otherwise noted.

PARAMETER		TEST CONDITIONS	MIN	TYP	MAX	UNIT
$V_{TT}/V_{O(TOL)}$	Output voltage tolerance to V_{TTREF}	$I_{V_{TT}/V_O} = -3\text{ A}$, across V_{DD}/V_{IN} voltage range	12	25	34	mV
		$I_{V_{TT}/V_O} = 3\text{ A}$, across V_{DD}/V_{IN} voltage range	-34	-25	-12	
I_{VOSRCL}	V_{TT}/V_O source current limit	Ramp output 0 A to 10 A, record current when VTT reaches lowest value	3.25		8	A
I_{VOSNCL}	$V_{TT}/V_O/V_{TT}$ sink current limit	Ramp output 0 A to -10 A, record current when VTT reaches highest value	3.5		10	A
R_{DSCHRG}	Discharge impedance	$V_{DDQSNS} = 0\text{ V}$, $V_{TT}/V_O = 0.3\text{ V}$, $EN = 0\text{ V}$		18	25	Ω
POWER-GOOD COMPARATOR						
$V_{TH(PG)}$	V_{TT}/V_O PGOOD threshold	PGOOD window lower (falling) threshold with respect to $V_{V_{TTREF}}$	-23.5%	-20%	-17.5%	
		PGOOD window upper (rising) threshold with respect to $V_{V_{TTREF}}$	17.5%	20%	23.5%	
		PGOOD hysteresis		5%		
$T_{PGSTUPDLY}$	PGOOD start up delay	Start up rising edge, V_{TTSNS} within 15% of $V_{V_{TTREF}}$		2		ms
$V_{PGODLOW}$	Output low voltage	$I_{SINK} = 4\text{ mA}$			0.4	V
$T_{PBADDLY}$	PGOOD bad delay	V_{TTSNS} is outside of the $\pm 20\%$ PGOOD window		1		μs
$I_{PGOODLK}$	Leakage current	$V_{TTSNS} = V_{TTREF}$ (PGOOD high impedance), $PGOOD = V_{DD}/V_{IN} + 0.2\text{ V}$			1	μA
VDDQSNS AND VTTREF OUTPUT						
$V_{V_{DDQSNS_UVLO}}$	V_{DDQSNS} undervoltage lockout	V_{DDQSNS} rising		780		mV
$V_{V_{DDQSNSUVHYS}}$	V_{DDQSNS} undervoltage lockout hysteresis			20		mV
$V_{V_{TTREF}}$	V_{TTREF} voltage		$V_{DDQSNS} / 2$			V
$V_{TTREF(\text{load_reg})}$	Load reg ΔV_{TTREF}	$-10\text{ mA} < I_{V_{TTREF}} < 10\text{ mA}$	$V_{DDQSNS} = 2.5\text{ V}$	-15	15	mV
			$V_{DDQSNS} = 1.8\text{ V}$	-15	15	
			$V_{DDQSNS} = 1.5\text{ V}$	-15	15	
			$V_{DDQSNS} = 1.35\text{ V}$	-15	15	
			$V_{DDQSNS} = 1.2\text{ V}$	-15	15	
$V_{TTREF(\text{accuracy})}$	V_{TTREF} voltage tolerance to V_{DDQSNS}	$-10\text{ mA} < I_{V_{TTREF}} < 10\text{ mA}$	$V_{DDQSNS} = 2.5\text{ V}$	49%	51%	
			$V_{DDQSNS} = 1.8\text{ V}$	49%	51%	
			$V_{DDQSNS} = 1.5\text{ V}$	49%	51.25%	
			$V_{DDQSNS} = 1.35\text{ V}$	49%	51.5%	
			$V_{DDQSNS} = 1.2\text{ V}$	49%	51.5%	
		$-3\text{ mA} < I_{V_{TTREF}} < 3\text{ mA}$	$V_{DDQSNS} = 1.5\text{ V}$	49%	51%	
			$V_{DDQSNS} = 1.35\text{ V}$	49%	51%	
			$V_{DDQSNS} = 1.2\text{ V}$	49%	51%	
			$V_{DDQSNS} = 1.2\text{ V}$	49%	51%	
$I_{V_{TTREFSRCL}}$	$V_{V_{TTREF}}$ source current limit	Sourcing current ramped from 0 A to 55 mA. Find when V_{TTREF} drops to half of its original value.	10	40		mA
$I_{V_{TTREFSNCL}}$	$V_{V_{TTREF}}$ sink current limit	Sinking current ramped from 0 A to 16.5 mA. Find when V_{TTREF} hits peak value.	12	15		mA
$I_{V_{TTREFDIS}}$	V_{TTREF} discharge current	$EN = 0\text{ V}$, $V_{DDQSNS} = 0\text{ V}$, $V_{TTREF} = 0.5\text{ V}$		1.3		mA
UVLO/EN LOGIC THRESHOLD						
$V_{VINUVVIN}$	UVLO threshold	Wakeup		2.18	2.25	V
$V_{VINUVVINHYS}$	UVLO threshold hysteresis	Hysteresis		50		mV
V_{ENIH}	High-level input voltage	Enable	1.7			V
V_{ENIL}	Low-level input voltage	Enable			0.3	V
V_{ENYST}	Hysteresis voltage	Enable		0.5		V
I_{ENLEAK}	Logic input leakage current	EN	-1		1	μA
THERMAL SHUTDOWN						

6.5 Electrical Characteristics (続き)

Over full temperature range, $T_A = -55^\circ\text{C}$ to 125°C , $V_{DD}/V_{IN} = 3.3\text{ V}$ and 2.375 V (for $V_{DD}/V_{IN} > V_{LDOIN}$), $V_{LDOIN} = 1.8\text{ V}$, $V_{DDQSN} = 1.8\text{ V}$, $V_{TTSNS} = 0.9\text{ V}$, $EN = V_{DD}/V_{IN}$, 標準の DDR アプリケーション unless otherwise noted. All voltage values are with respect to the network ground (AGND) pin unless otherwise noted.

PARAMETER		TEST CONDITIONS	MIN	TYP	MAX	UNIT
T_{SON}	Thermal shutdown threshold	Shutdown temperature		210		°C
		Hysteresis		12		

6.6 Typical Characteristics

For [Figure 6-1](#) through [Figure 6-10](#), (3 × 150-μF T530D157M010ATE005 tantalum + 4 × 4.7-μF MLCC) or equivalent capacitance/ESR are used on VTT output

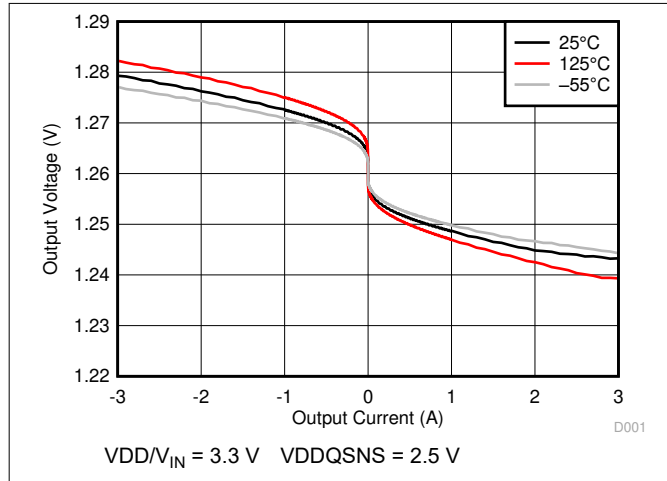

Figure 6-1. Output Voltage vs Output Current

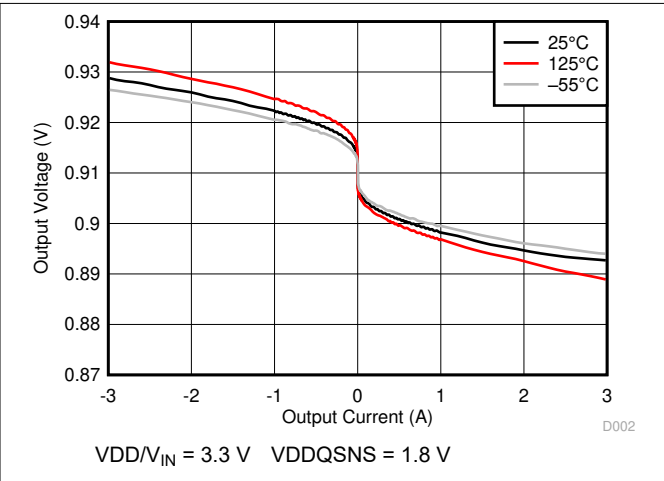

Figure 6-2. Output Voltage vs Output Current

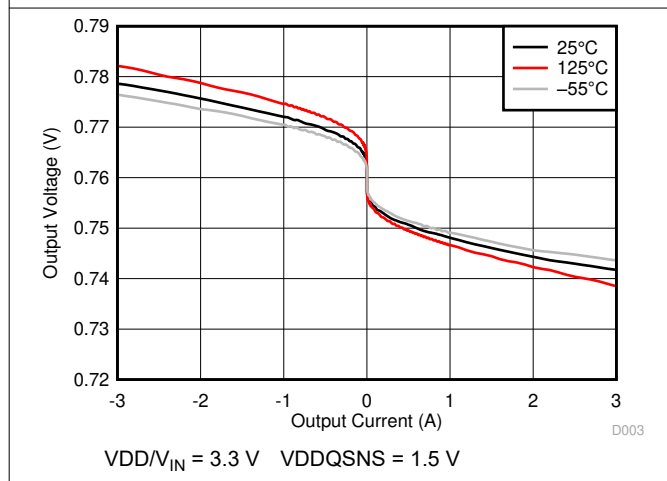

Figure 6-3. Output Voltage vs Output Current

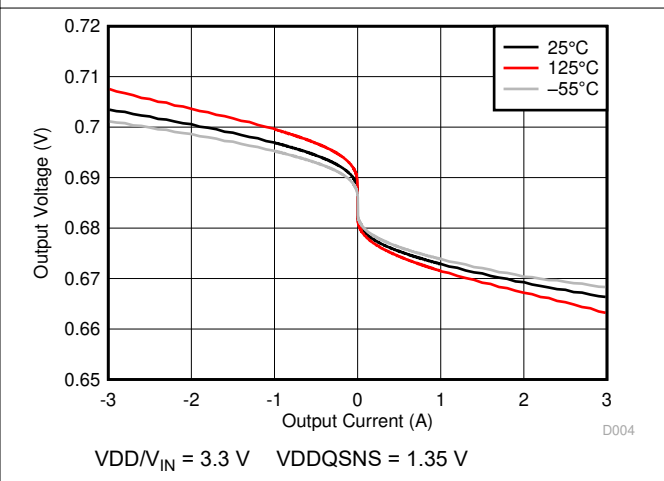

Figure 6-4. Output Voltage vs Output Current

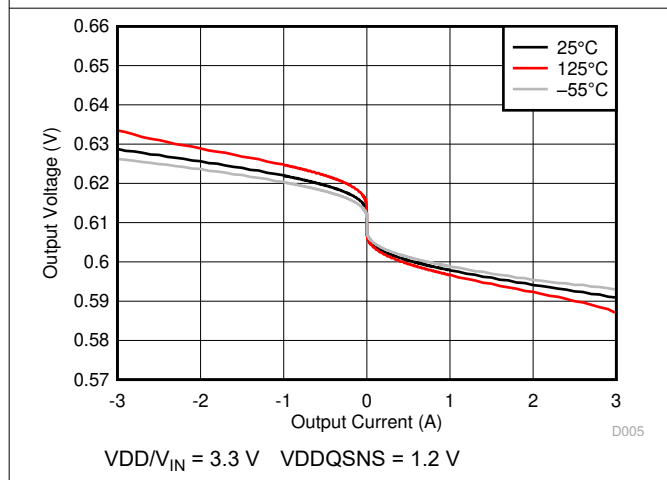

Figure 6-5. Output Voltage vs Output Current

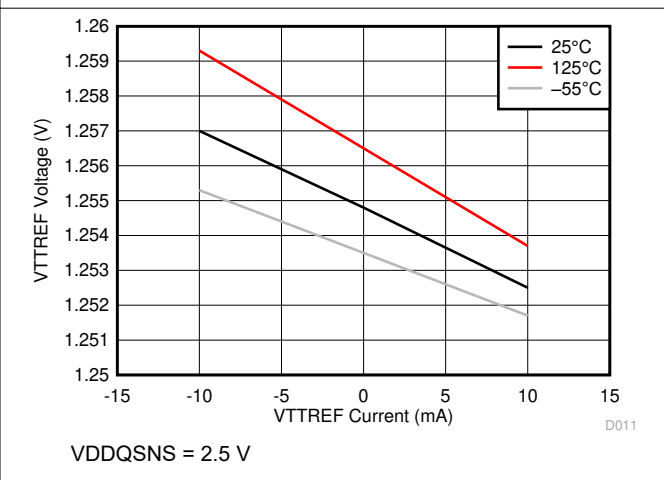

Figure 6-6. VTTREF Voltage vs VTTREF Current

6.6 Typical Characteristics (continued)

For [Figure 6-1](#) through [Figure 6-10](#), (3 × 150-μF T530D157M010ATE005 tantalum + 4 × 4.7-μF MLCC) or equivalent capacitance/ESR are used on VTT output

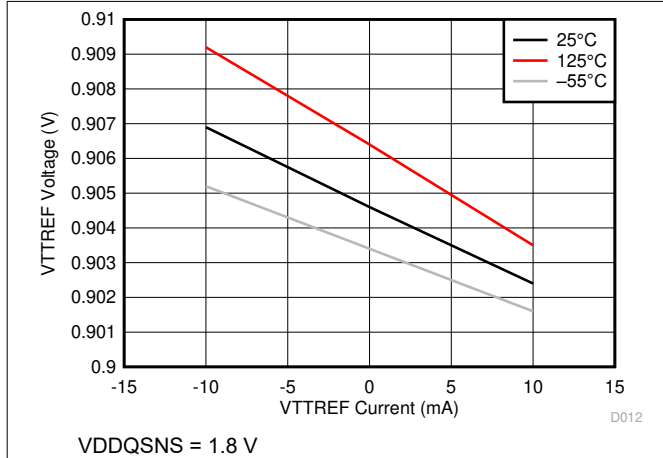

Figure 6-7. VTTREF Voltage vs VTTREF Current

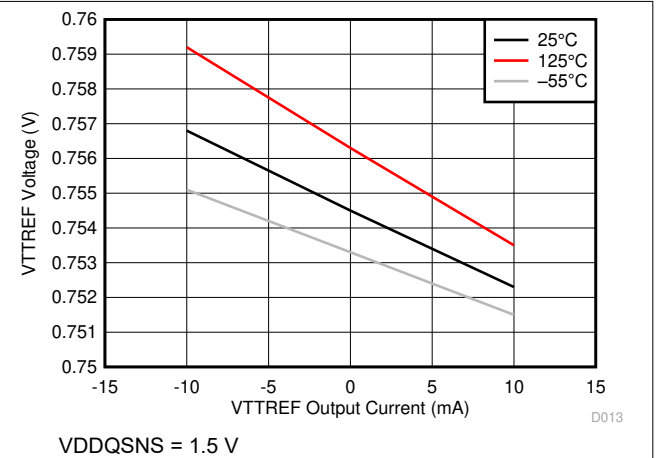

Figure 6-8. VTTREF Voltage vs VTTREF Current

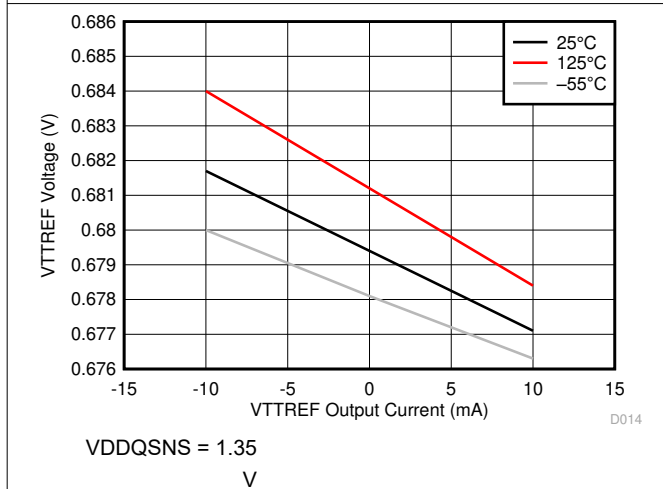

Figure 6-9. VTTREF Voltage vs VTTREF Current

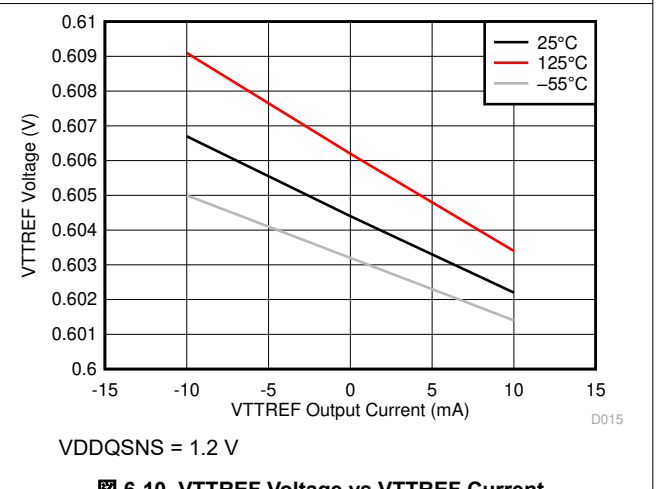

Figure 6-10. VTTREF Voltage vs VTTREF Current

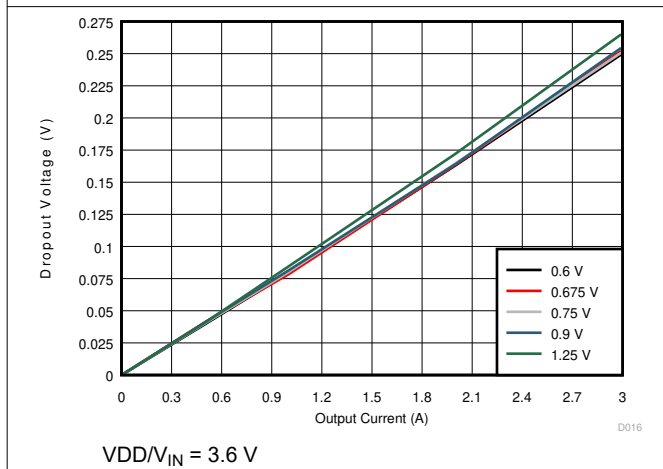

Figure 6-11. Dropout Voltage vs Output Current

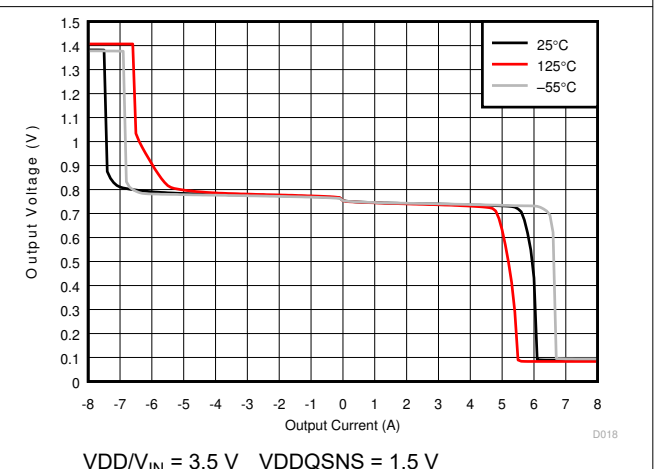
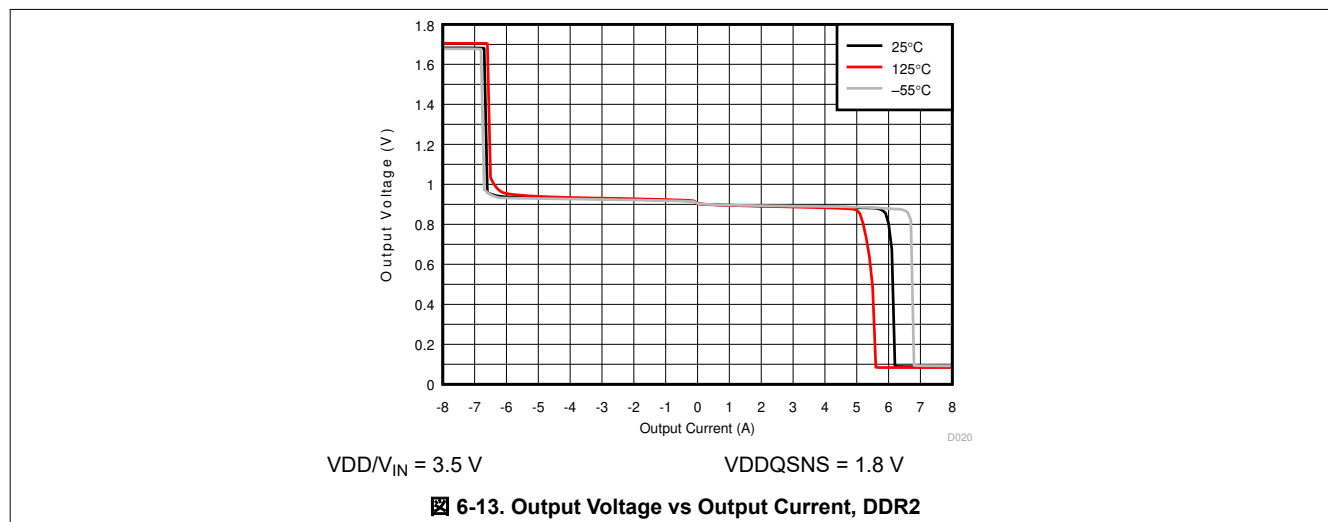

Figure 6-12. Output Voltage vs Output Current, DDR3

6.6 Typical Characteristics (continued)

For [Figure 6-1](#) through [Figure 6-10](#), (3 × 150-μF T530D157M010ATE005 tantalum + 4 × 4.7-μF MLCC) or equivalent capacitance/ESR are used on VTT output



7 Detailed Description

7.1 Overview

The TPS7H3301-SP device is a sink and source double data rate (DDR) termination regulator specifically designed for low input voltage, low-noise systems where space and weight is a key consideration.

7.2 Functional Block Diagram

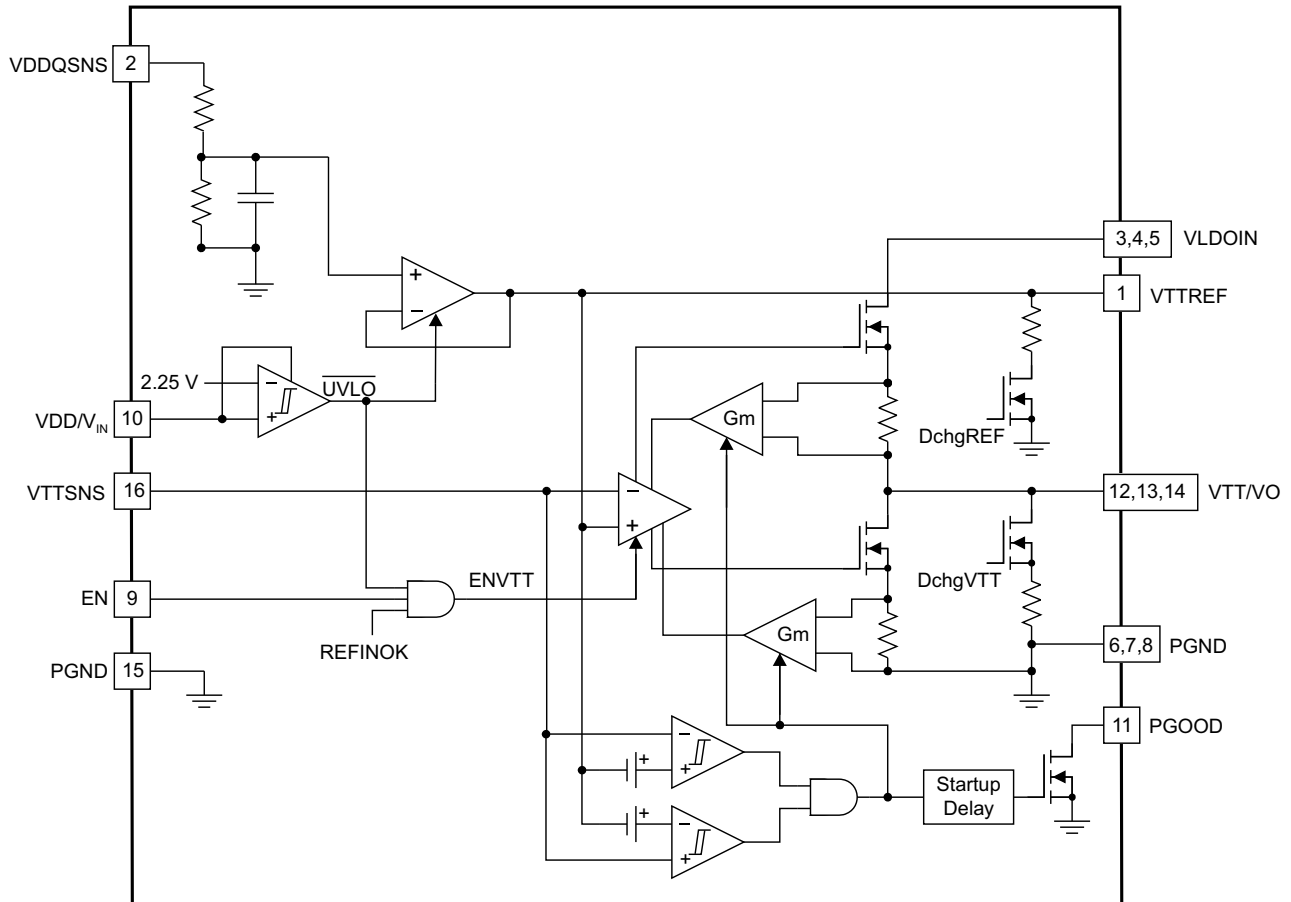

7.3 Feature Description

7.3.1 VTT/VO Sink and Source Regulator

The TPS7H3301-SP is a 3-A sink and source tracking termination regulator specifically designed for low input voltage, and low external component count systems where space is a key application parameter. The TPS7H3301-SP integrates a high-performance, low-dropout (LDO) linear regulator that is capable of both sinking and sourcing current. The LDO regulator employs a fast feedback loop so that ceramic capacitors can be used to support the fast load transient response. To achieve tight regulation with minimum effect of trace resistance, a remote sensing pin (VTTSENS) should be connected to the positive pin of the output capacitor(s) as a separate trace from the high-current path of VTT/VO.

The TPS7H3301-SP has a dedicated pin (VLDOIN) for VTT power supply to minimize the LDO power dissipation on user application. The minimum VLDOIN voltage is 400 mV above the 1/2 VDDQSNS voltage or as highlighted in [セクション 6.5](#) (VLDOIN to VTT headroom) for various load conditions.

7.3.2 Reference Input (VDDQSNS)

The output voltage, VTT/VO, is regulated to VTTREF. VDDQSNS incorporates an integrated resistor divider network. VDDQSNS should be connected to the memory supply bus (VDDQ). The TPS7H3301-SP supports

VDDQSNS voltage from 1 V to 3.5 V, making it versatile and ideal for many types of low-power LDO applications.

7.3.3 Reference Output (VTTREF)

When it is configured for DDR termination applications, VTTREF buffers the DDR VTT reference voltage for the memory application. The VTTREF block consists of an on-chip 1/2 resistor divider and a low-pass filter (LPF). VTTREF tracks 1/2 of VDDQSNS within 15 mV. It is capable of supporting both a sourcing and sinking load of 10 mA. VTTREF becomes active when VDDQSNS voltage rises to 0.78 V and VDD/V_{IN} is above the UVLO threshold. When VTTREF is less than 0.76 V, VTTREF is disabled and subsequently discharges to GND through an internal MOSFET. VTT/V_O is also discharged following the discharge of VTTREF. VTTREF is independent of the EN pin state. To meet stability criteria, a ceramic capacitor of 0.1- μ F minimum must be installed close to VTTREF (pin1). Capacitor value at VTTREF (pin 1) must not exceed 2.2 μ F.

7.3.4 EN Control (EN)

When EN is driven high, the TPS7H3301-SP VTT/V_O regulator begins normal operation. When EN is driven low, VTT/V_O discharges to GND through an internal 18- Ω MOSFET. VTTREF remains on when EN is driven low. EN is not tied high internally to prevent power sequencing issues with an external signal that may be controlling the enable. EN is a floating input and not internally tied, thus the user can have complete control over where and when the EN signal is generated. EN feeds directly into power-good (PGOOD). When enable is low, PGOOD is low.

7.3.5 Power-Good Function (PGOOD)

The TPS7H3301-SP provides an open-drain PGOOD output that goes high when the VTT/V_O output is within 20% of VTTREF (typ). PGOOD deasserts within 1 μ s after the output exceeds the size of the power-good window. During initial VTT/V_O startup, PGOOD asserts high 2 ms (typ) after the VTT/V_O enters power-good window. Because PGOOD is an open-drain output, a 100k Ω pullup resistor between PGOOD and a stable active supply voltage rail is recommended for proper operation.

7.3.6 V_{TT} Current Protection

The LDO has a constant overcurrent limit (OCL). See [Figure 6-13](#) for typical behavior across temperature.

7.3.7 V_{IN} UVLO Protection

For VDD/V_{IN} undervoltage lockout (UVLO) protection, the TPS7H3301-SP monitors VDD/V_{IN} voltage. When the VDD/V_{IN} voltage is lower than the UVLO threshold voltage, both the VTT and VTTREF regulators are powered off. This shutdown is a non-latch protection.

7.3.8 Thermal Shutdown

The TPS7H3301-SP monitors its junction temperature. If the device junction temperature exceeds its threshold value, (typically 210°C), the VTT/V_O and VTTREF regulators are both shutoff and discharged by the internal discharge MOSFETs. This shutdown is a non-latch protection.

7.4 Device Functional Modes

The TPS7H3301-SP 3-A sink and source LDO provides low output noise to meet system needs. In order to improve efficiency in the LDO, TPS7H3301-SP LDO can operate from low VLDOIN voltage rail, thus using dual voltage source one for the VLDOIN that supports high-current and an alternate voltage source that provides voltage for VDDQSNS pin.

In some cases VLDOIN and VDDQSNS pins are tied together. In the memory system, VDDQ is a high-current supply that powers the core, the I/O, and the logic of the memory. VTTREF is a low-current, precision reference voltage that provides a threshold between a logic high (one) and a logic low (zero) that adapts to changes in the I/O supply voltage. By providing a precision threshold that adapts to the supply voltage, VTTREF realizes wider noise margins than those possible with a fixed threshold and normal variations in termination and drive impedance. Specifications vary for different DDR technologies. For example DDR3 JEDEC JESD79-3F specifies 0.49 to 0.51 times VDDQ and draws only tens to hundreds of microamps. The TPS7H3301-SP VTTREF is designed to sink and source up to 10 mA.

8 Application and Implementation

注

以下のアプリケーション情報は、TI の製品仕様に含まれるものではなく、TI ではその正確性または完全性を保証いたしません。個々の目的に対する製品の適合性については、お客様の責任で判断していただくこととなります。お客様は自身の設計実装を検証しテストすることで、システムの機能を確認する必要があります。

8.1 Application Information

The TPS7H3301-SP device is a highly-integrated sink and source LDO. The device is targeted to support VTT voltage for DDR memory applications and is capable of sourcing and sinking 3-A load current. The TPS7H3301-SP user's guide is available on www.ti.com, [SLVUAK2](#). The guide highlights standard EVM test results, schematic, and bill of materials (BOM) for reference.

8.2 Typical Application

The design example describes a 2.5-V V_{IN} , DDR3 configuration.



図 8-1. Typical Application Circuit

8.2.1 Design Requirements

See the [セクション 6.3](#) for recommended limits.

8.2.2 Detailed Design Procedure

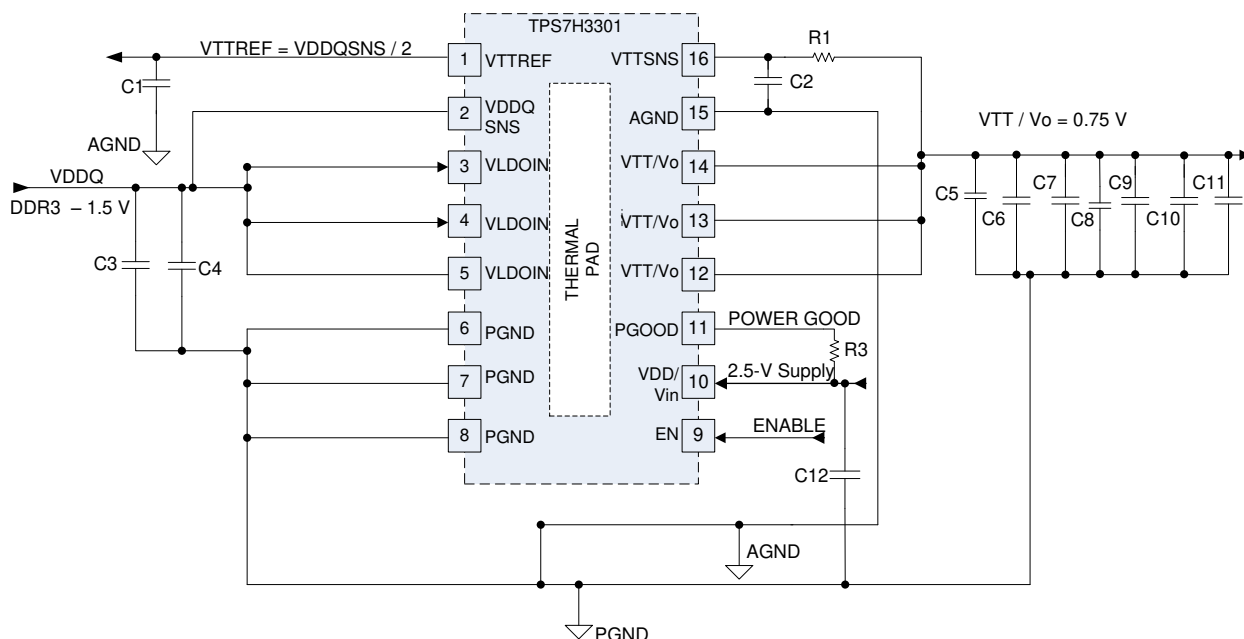
表 8-1. Design Example 1 List of Materials

REFERENCE DESIGNATOR	DESCRIPTION	SPECIFICATION	PART NUMBER	MANUFACTURER
R1	Resistor	392 Ω	CRCW0603392RFKEA	
R3		100 k Ω	CRCW0603100KJNEA	
C3, C5, C6, C7	Capacitor	150 μ F, 10 V	T530D157M010ATE005	Kemet
C2		1000 pF	GRM188R71H102KA01D	MuRata
C1		0.1 μ F	08053C104KAT2A	AVX
C4, C8, C9, C10, C11		4.7 μ F, 10 V	1210ZC475KAT2A	Murata
C12		10 μ F, 10 V	GRM21BR71A106KE51L	Murata

8.2.2.1 VDD/V_{IN} Capacitor

Add a ceramic capacitor, with a value between 1- and 10- μ F, placed close to the VDD/V_{IN} pin to minimize high frequency noise from the supply.

8.2.2.2 VLDO Input Capacitor

Depending on the trace impedance between the VLDOIN/VDDQ bulk power supply to the device, a transient increase of source current is supplied mostly by the charge from the VLDOIN/VDDQ input capacitor. Use a 150- μ F (or greater) tantalum capacitor in parallel with a 4.7- μ F ceramic capacitor to supply this transient charge. Provide more input capacitance as more output capacitance is used at VTT/V_O.

8.2.2.3 VTT Output Capacitor

For stable operation, the total capacitance of the VTT/V_O output pin must be greater than 470 μ F. Attach three, 3 \times 150- μ F low-ESR tantalum capacitors in parallel with ceramic capacitors to minimize the effect of equivalent series resistance (ESR) and equivalent series inductance (ESL). If the total parallel ESR is greater than 2 m Ω , insert an R-C filter between the output and the VTTSNS input to achieve loop stability. The R-C filter time constant should be almost the same as or slightly lower than the time constant of the output capacitor and its ESR.

8.2.2.4 VTTSNS Connection

To achieve tight regulation with minimum effect of trace resistance, a remote sensing pin (VTTSNS) should be connected to the positive pin of the VTT pin output capacitor or capacitors as a separate trace from the high-current path from VTT. Consider adding a low-pass R-C filter at the VTTSNS pin in case the ESR of the VTT output capacitor or capacitors is larger than 2 m Ω . The R-C filter time constant should be approximately the same or slightly lower than the time constant of the VTT output capacitance and ESR.





図 8-2. R-C Filter for VTTSNS

8.2.2.5 Low V_{IN} Applications

TPS7H3301-SP can be used in an application system where either a 2.5-V rail or a 3.3-V rail is available. The TPS7H3301-SP minimum input voltage requirement is 2.375 V. If a 2.5-V rail is used, ensure that the absolute minimum voltage (both DC and transient) at the device pin is 2.375 V or greater. The voltage tolerance for a 2.5-V rail input is between -5% and 5% accuracy, or better.

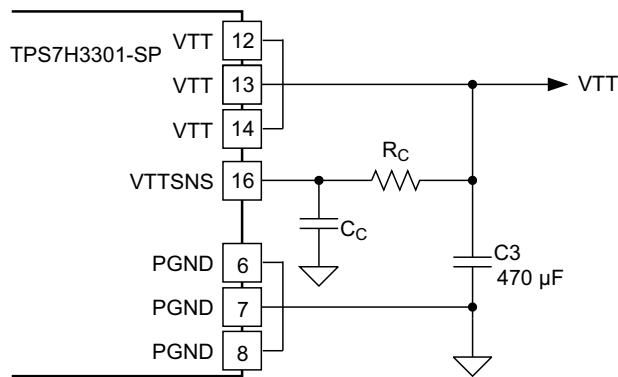
8.2.2.6 S3 and Pseudo-S5 Support

The TPS7H3301-SP provides S3 support by an EN function. The EN pin could be connected to an SLP_S3 signal in the end application. Both VTTREF and VTT/V_O are on when EN = high (S0 state). VTTREF is maintained while VTT/V_O is turned off and discharged via an internal discharge MOSFET when EN = low (S3 state). Please notice that the EN signal controls only the output buffer for VTT/V_O and therefore, while in S3 state, VDDQSNS is present in order to maintain data in volatile memory. As a result, when EN is set high to exit the S3 state, it is desired to bring V_O/VTT into regulation as fast as possible. This causes an output current controlled by the current limit of the device and the output capacitors.

When EN = low and the VDDQSNS voltage is less than 0.78 V, TPS7H3301-SP enters pseudo-S5 state. Both VTT/V_O and VTTREF outputs are turned off and discharged to GND through internal MOSFETs when pseudo-S5 support is engaged (S4/S5 state).  8-3 shows a typical startup and shutdown timing diagram for an application that uses S3 and pseudo-S5 support.

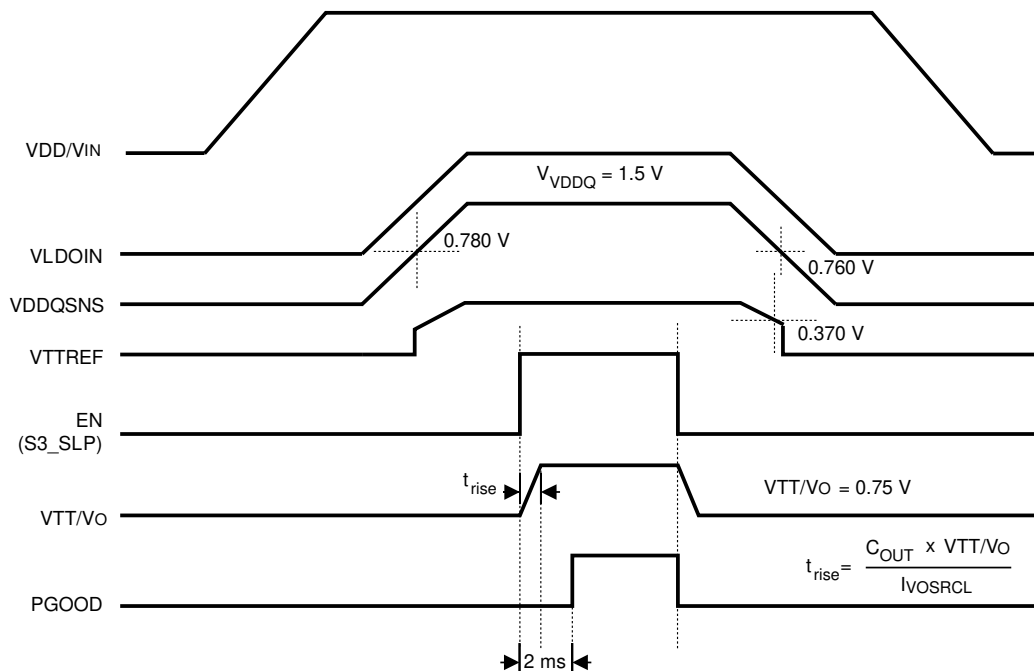

 8-3. Typical Timing Diagram for S3 and Pseudo-S5 Support

8.2.2.7 Tracking Startup and Shutdown

The TPS7H3301-SP supports tracking startup of VDDQ and shutdown when EN is tied directly to the system bus and not used to turn on or turn off the device. During tracking startup, VTT/V_O follows VTTREF once VDDQSNS voltage is greater than 0.78 V. VDDQSNS incorporates a resistor divider network and a time constant of about 445 μ s. The rise time of the VTT/V_O output is then a function of the rise time of VDDQSNS. If the VDDQSNS rise time is larger than 445 μ s, PGOOD is asserted 2 ms after VTT/V_O is within $\pm 20\%$ of VTTREF. During tracking shutdown, VTT/V_O falls following VTTREF until VTTREF reaches 0.37 V. Once VTTREF falls below 0.37 V, the internal discharge MOSFETs are turned on and quickly discharge both VTTREF and VTT/V_O to GND. PGOOD is deasserted once VTT/V_O is beyond the $\pm 20\%$ range of VTTREF.  8-4 shows the typical timing diagram for an application that uses tracking startup and shutdown.

There are no sequencing requirements between VDD/V_{IN} and VLDOIN. If VLDOIN is applied first followed by VDD/V_{IN} there is no issue. VDD/V_{IN} UVLO protection monitors VDD/V_{IN} voltage. When VDD/V_{IN} is lower than UVLO threshold both VTT and VTTREF regulators are powered off.

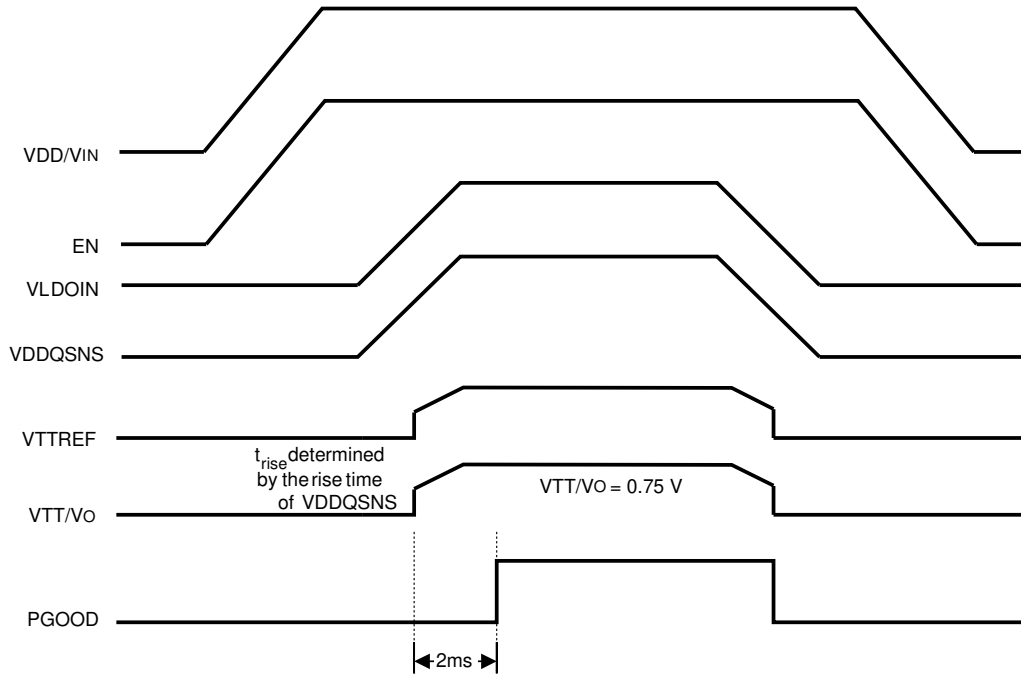

8-4. Typical Timing Diagram of Tracking Startup and Shutdown

8.2.2.8 Output Tolerance Consideration for VTT DIMM or Module Applications

The TPS7H3301-SP is specifically designed to power up the memory termination rail (as shown in 8-5). The DDR memory termination structure determines the main characteristics of the VTT rail, which is to be able to sink and source current while maintaining acceptable VTT tolerance. See 8-6 for typical characteristics for a single memory cell.

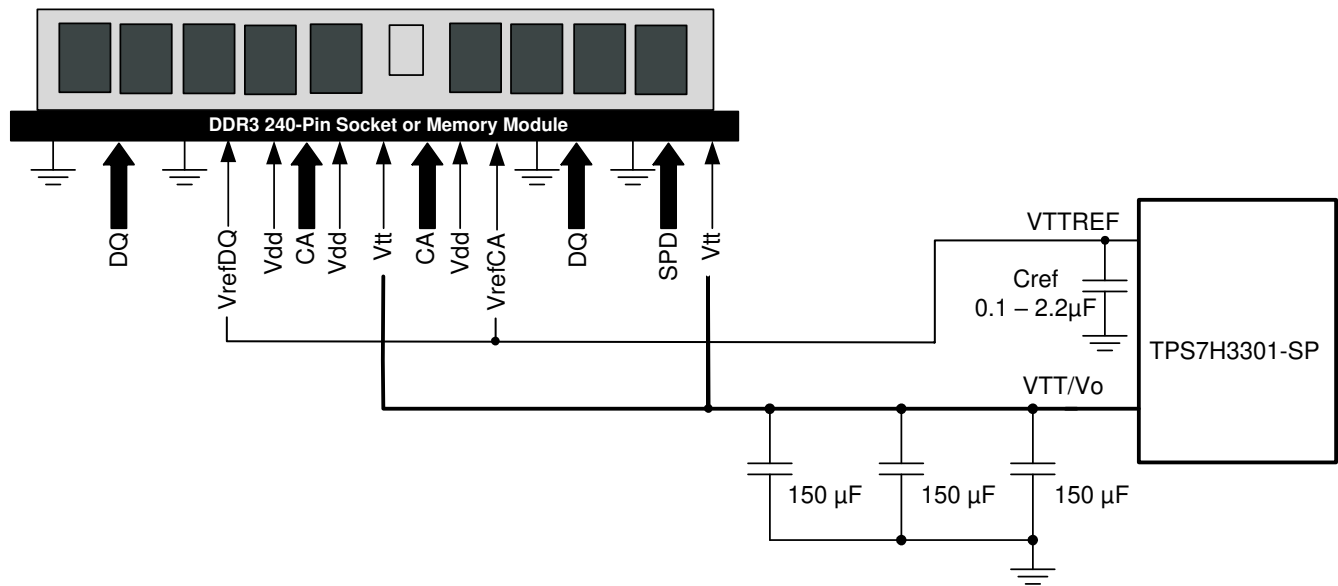

8-5. Typical Application Diagram for DDR3 VTT DIMM/Module Using TPS7H3301-SP



图 8-6. DDR Physical Signal System SSTL Signaling

In 图 8-6, when Q1 is on and Q2 is off:

- Current flows from VDDQ via the termination resistor to VTT.
- VTT sinks current.

In 图 8-6, when Q2 is on and Q1 is off:

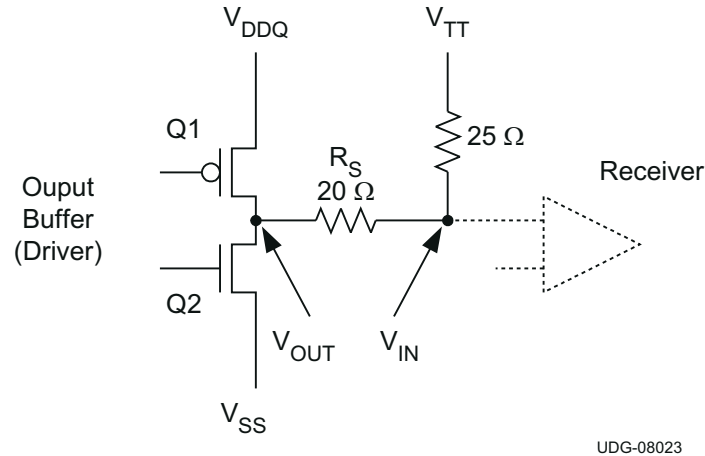
- Current flows from VTT via the termination resistor to GND.
- VTT sources current.

Because VTT accuracy has a direct impact on the memory signal integrity, it is imperative to understand the tolerance requirement on VTT. Based on JEDEC VTT specifications for DDR and DDR2. See 表 8-2 for detailed information and JEDEC relevant specifications.

$V_{TTREF} - 40 \text{ mV} < V_{TT} < V_{TTREF} + 40 \text{ mV}$, for both DC and AC conditions

The specification itself indicates that VTT must keep track of VTTREF for proper signal conditioning.

The TPS7H3301-SP ensures the regulator output voltage to be:

$V_{TTREF} - 34 \text{ mV} < V_{TT} < V_{TTREF} + 34 \text{ mV}$, for both DC and AC conditions and $-3 \text{ A} < I_{V_{TT}} < 3 \text{ A}$

The regulator output voltage is measured at the regulator side, not the load side. The tolerance is applicable to DDR, DDR2, DDR3 and low-power DDR3/DDR4 applications (see 表 8-2 for detailed information). To meet the stability requirement, a minimum output capacitance of 470 μF is needed, combination of both tantalum and ceramic capacitors. Considering the actual tolerance on the MLCC capacitors, four or higher 4.7- μF ceramic capacitors in parallel with 3 \times 150- μF low-ESR tantalum capacitor are sufficient to meet the above requirement. Higher ESR tantalum capacitors will require multiple tantalum capacitors in parallel with ceramic capacitors to meet system needs.

表 8-2. DDR, DDR2, DDR3, and LP DDR3 Termination Technology and Differences

	DDR	DDR2	DDR3	LOW POWER DDR3 (DDR3L)
FSB data rates	200, 266, 333 and 400 MHz	400, 533, 677 and 800 MHz	800, 1066, 1330 and 1600 MHz	Same as DDR3
Termination	Motherboard termination to VTT for all signals	On-die termination for data group. VTT/V _O used for termination of address, command and control signals.	On-die termination for data group. VTT/V _O used for termination of address, command and control signals.	Same as DDR3
Termination current demand	Max sink and source transient currents of up to 2.6 A to 2.9 A	Not as demanding <ul style="list-style-type: none"> • Only 34 signals (address, command, control) tied to VTT/V_O • ODT handles data signals Less than 1 A of burst current	Not as demanding <ul style="list-style-type: none"> • Only 34 signals (address, command, control) tied to VTT/V_O • ODT handles data signals Less than 1 A of burst current	Same as DDR3
Voltage level	2.5-V core and I/O 1.25-V VTT	1.8-V core and I/O 0.9-V VTT	1.5-V core and I/O 0.75-V VTT	1.35-V core and I/O 0.68-V VTT
Relevant JEDEC specification	JESD79F (SSTL_2 JESD8-9B)	DDR2 JESD79-2F (SSTL_18 JESD8-15)	DDR3 JESD79-3F	DDR3L JESD79-3-1A.01

The TPS7H3301-SP is designed as a G_m-driven LDO. The voltage droop between the reference input and the output regulator is determined by the transconductance and output current of the device. The typical G_m is 250 S at 3 A and changes with respect to the load in order to conserve the quiescent current (that is, the G_m is very low at no load condition). The G_m LDO regulator is a single pole system. Its unity gain bandwidth for the voltage loop is only determined by the output capacitance, as a result of the bandwidth nature of the G_m (see 式 1).

$$F_{UGBW} = \frac{G_m}{2 \times \pi \times C_{OUT}} \tag{1}$$

where

- F_{UGBW} is the unity gain bandwidth
- G_m is transconductance
- C_{OUT} is the output capacitance

There are two limitations to this type of regulator when it comes to the output bulk capacitor requirement. To maintain stability, the zero location contributed by the ESR of the output capacitors should be greater than the –3-dB point of the current loop. This constraint means that higher ESR capacitors should not be used in the design. In addition, the impedance characteristics of the ceramic capacitor should be well understood in order to prevent the gain peaking effect around the G_m –3-dB point because of the large ESL, the output capacitor, and parasitic inductance of the VTT/V_O trace.

☒ 8-7 shows the bode plot simulation for a typical DDR3 configuration of the TPS7H3301-SP, where:

- VDD/V_{IN} = 2.4 V
- V_{VLD0IN} = 1.5 V
- VTT/V_O = 0.75 V
- I_{IO} = 2 A
- 3 × 150-μF low-ESR tantalum capacitors (T530D157M010ATE005) in parallel with 4 × 4.7-μF ceramic capacitor
- ESR = 1.66 mΩ
- ESL = 800 pH

The unity-gain bandwidth is approximately 87.3 kHz and the phase margin is 82°. The 0-dB level is crossed, the gain peaks because of the ESL effect. However, the peaking is kept well below 0 dB.

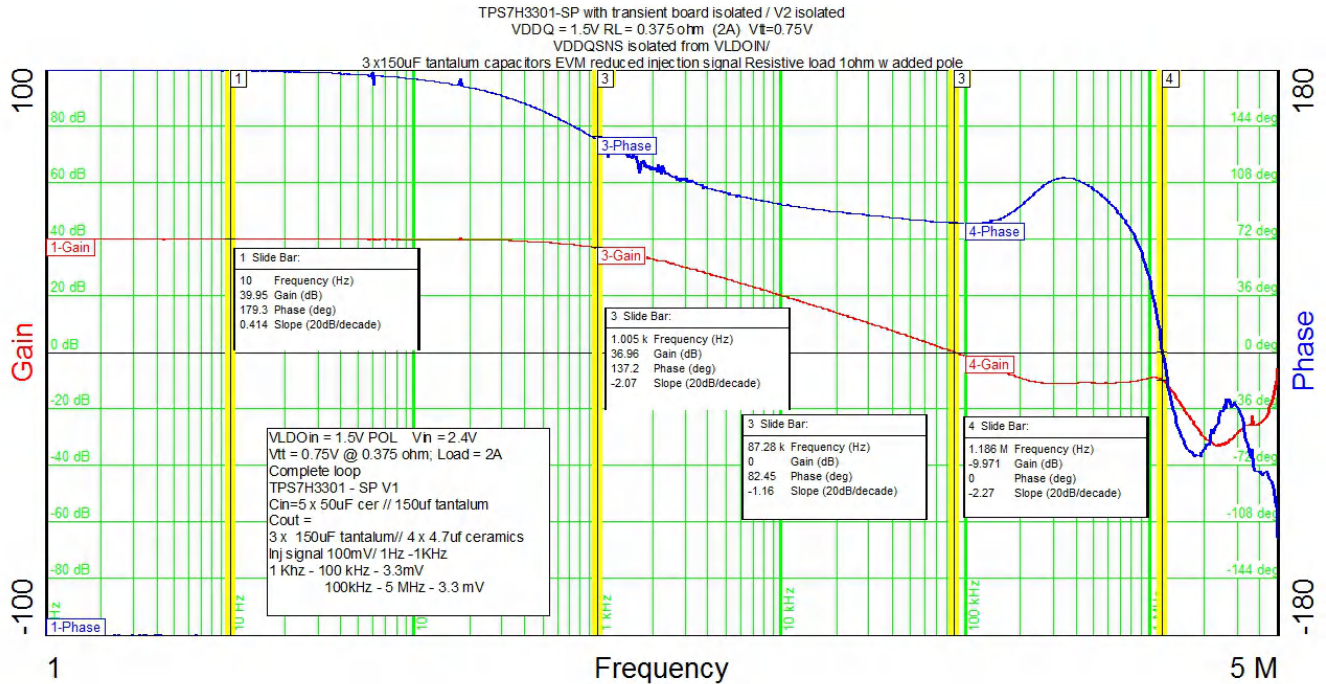

8-7. Bode Plot for a Typical DDR3 Configuration

6-3 shows the load regulation and 8-8 shows the transient response for a typical DDR3 configuration. When the regulator is subjected to worst case ± 3 -A load step. The current shown only represents the device sourcing 3 A due to location of current probe.

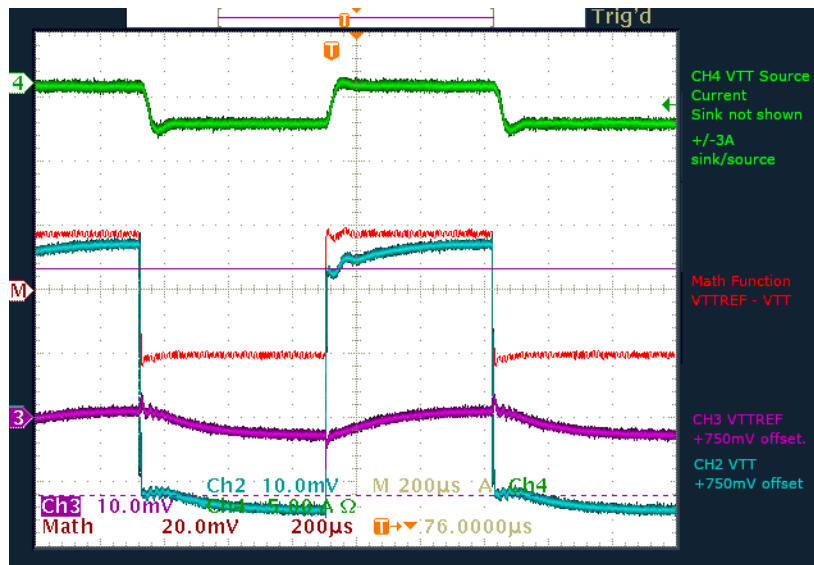

8-8. Transient Plot

8.2.2.9 LDO Design Guidelines

The minimum input (VLDOIN) to output voltage (VTT/V_O) difference (headroom) decides the lowest usable supply voltage G_m-driven to drive a certain load. For TPS7H3301-SP, a minimum of 300 mV (VLDOIN_{MIN} – VTT/V_O MAX) is needed in order to support a G_m driven sourcing current of 3 A based on a design of VLDOIN = 3.3 V and C_{OUT} = 470 μ F. Because the TPS7H3301-SP is essentially a G_m-driven LDO, its impedance

characteristics are both a function of the $1/G_m$ and $R_{DS(on)}$ of the sourcing MOSFET (see 8-9). The current inflection point of the design is between 3 A and 4 A. When I_{SRC} is less than the inflection point, the LDO is considered to be operating in the G_m region; when I_{SRC} is greater than the inflection point but less than the overcurrent limit point, the LDO is operating in the $R_{DS(on)}$ region. The typical sourcing $R_{DS(on)}$ is 154 m Ω with $V_{IN} = 3 V$ and $T_J = 125^\circ C$.

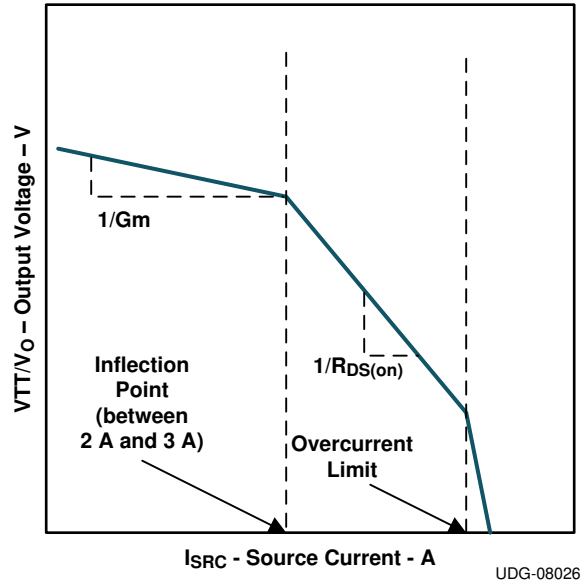

8-9. TPS7H3301-SP Impedance Characteristics

8.2.3 Application Curve

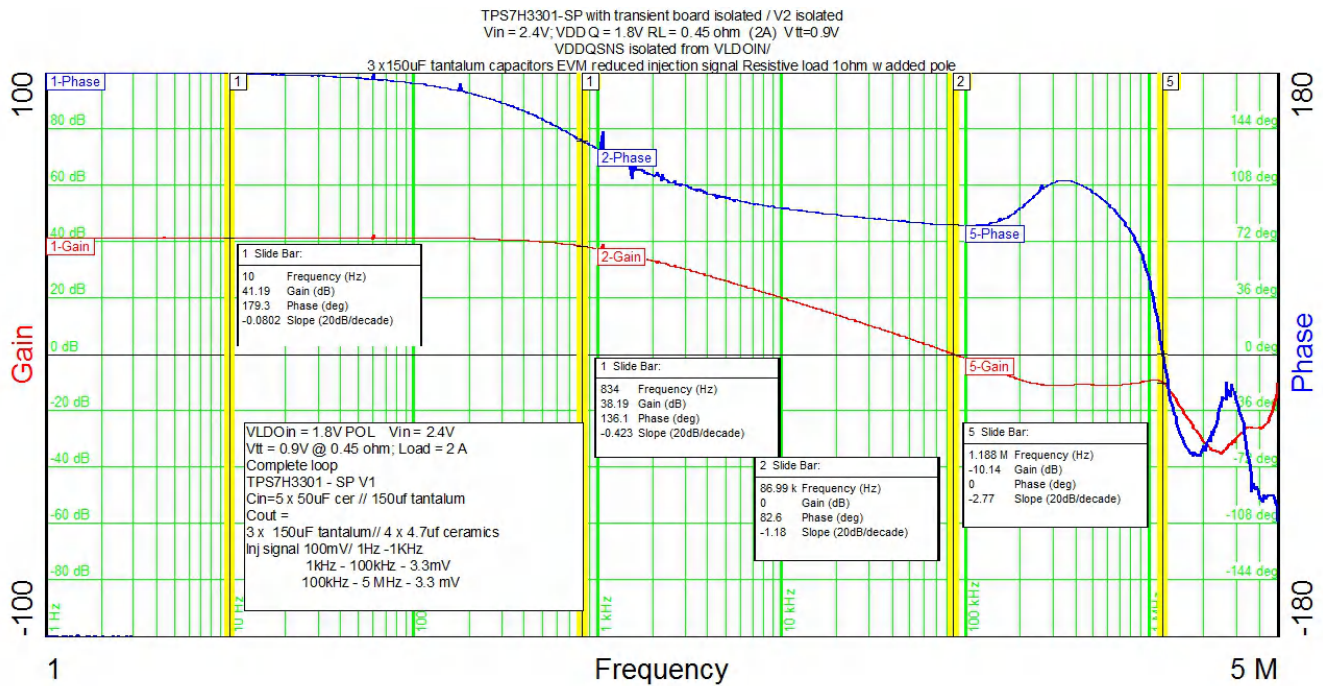

8-10. DDR2 2-A Load $V_{IN} = 2.4 V$, $V_{TT}/V_O = 0.9 V$

Power Supply Recommendations

TPS7H3301-SP is designed to support DDR, DDR2, DDR3, DDR3L, and DDR4 VTT applications. TPS7H3301-SP VLDOIN supports voltage range from 0.9 V to 3.5 V. The supply must be well regulated. Having a separate VLDOIN supply from DDR VDDQ allows designer to optimize system efficiency. VDD/V_{IN} is used to bias the TPS7H3301-SP IC and its voltage range from 2.375 V to 3.5 V. This supply must be well regulated and bypassed with a ceramic capacitor with a value of 1 μ F and 10 μ F. TI recommends that VLDOIN and DDR supply VDDQ be isolated from each other. If this is not possible then an RC filter must be used to isolate VLDOIN and VDDQSNS. However, in so doing the dynamic tracking of VTT and VTTREF will be lost. See the EVM user's guide [SLVUAK2](#) for additional details.

9 Layout

9.1 Layout Guidelines

Consider the following points before starting the TPS7H3301-SP layout design.

- The input bypass capacitor for VLDOIN should be placed as close as possible to the pin with short and wide connections.
- The output capacitor for VTT/V_O should be placed close to the pin with short and wide connection in order to avoid additional ESR and/or ESL trace inductance.
- VTTSNS should be connected to the positive node of VTT/V_O output capacitors as a separate trace from the high-current power line. This configuration is strongly recommended to avoid additional ESR and/or ESL. If sensing the voltage at the point of the load is required, it is recommended to attach the output capacitor or capacitors at that point. Also, it is recommended to minimize any additional ESR and/or ESL of ground trace between the GND pin and the output capacitor or capacitors.
- Consider adding low-pass filter at VTTSNS if the ESR of the VTT/V_O output capacitor or capacitors is larger than 2 mΩ.
- VDDQSNS can be connected separately from VLDOIN. Remember that this sensing potential is the reference voltage of VTTREF. Avoid any noise-generating lines.
- The negative node of the VTT/V_O output capacitor or capacitors and the VTTREF capacitor should be tied together by avoiding common impedance to the high-current path of the VTT/V_O sink and source current.
- The GND and PGND pins should be connected to the thermal land underneath the die pad with multiple vias connecting to the internal system ground planes (for better result, use at least two internal ground planes). Use as many vias as possible to reduce the impedance between PGND/GND and the system ground plane. Also, place bulk caps close to the DIMM/module or memory load point and route the VTTSNS to the DIMM/module load sense point.
- In order to effectively remove heat from the package, properly prepare the thermal land. Apply solder directly to the package's thermal pad. The wide traces of the component and the side copper connected to the thermal land pad help to dissipate heat. Numerous vias, 0.33 mm in diameter or smaller, connected from the thermal land to the internal/solder side ground plane or planes should also be used to help dissipation.

9.2 Layout Example



図 9-1. Layout Recommendation

9.3 Thermal Considerations

VTT/V_O current can flow in both source and sink directions. As the TPS7H3301-SP is a linear regulator, power is dissipated internal to the device. When the device is sourcing current, the voltage difference between VLDOIN and VTT/V_O times IO (I_{IO}) current becomes the power dissipation as shown in 式 2.

$$P_{DISS_SRC} = (V_{VLDOIN} - V_{VO}) \times I_{O_SRC} \quad (2)$$

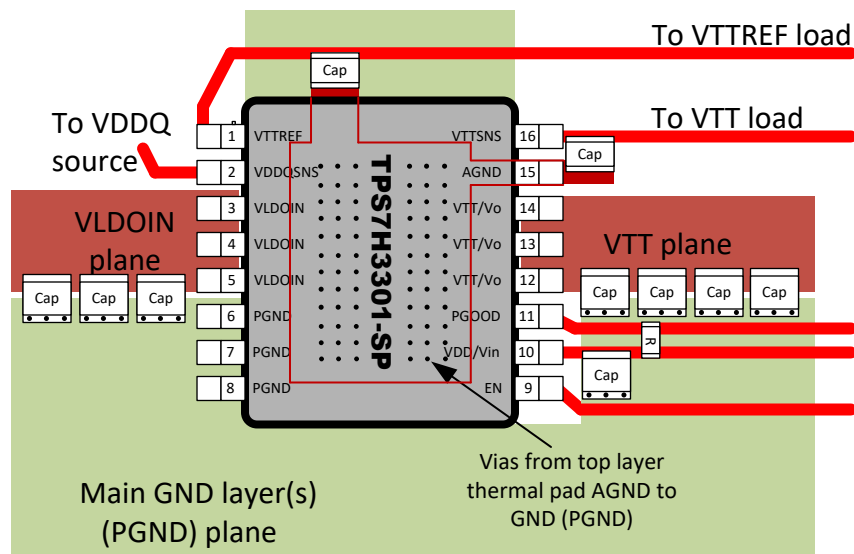
In this case, if VLDOIN is connected to an alternative power supply lower than the VDDQ voltage, overall power loss can be reduced. For the sink phase, V_O voltage is applied across the internal LDO regulator and the power dissipation (P_{DISS_SNK}) can be calculated by 式 3.

$$P_{DISS_SNK} = V_{VO} \times I_{O_SNK} \quad (3)$$

Because the device does not sink and source current at the same time and the IO current may vary rapidly with time, the actual power dissipation should be the time average of the above dissipations over the thermal relaxation duration of the system. Another source of power consumption is the current used for the internal current control circuitry from the VDD/V_{IN} supply and the VLDOIN supply. This can be estimated as P_{VDD/V_{IN}} = 105mW and P_{V_{LODIN}} = 4.2mW or less during normal operating conditions. This power must be effectively dissipated from the package.

The thermal performance of an LDO depends on the printed circuit board (PCB) layout. Because the TPS7H3301-SP device is shipped unformed, only the recommended heat pad pattern is shown. Lead pad placement depends on final form factor.

To further improve the thermal performance of this device, using a larger than recommended thermal land as well as increasing the number of vias helps lower the thermal resistance from junction to heat slug.

10 Device and Documentation Support

10.1 Device Support

10.1.1 サード・パーティ製品に関する免責事項

サード・パーティ製品またはサービスに関するテキサス・インスツルメンツの出版物は、単独またはテキサス・インスツルメンツの製品、サービスと一緒に提供される場合に関係なく、サード・パーティ製品またはサービスの適合性に関する是認、サード・パーティ製品またはサービスの是認の表明を意味するものではありません。

10.2 Documentation Support

10.2.1 Related Documentation

For related documentation see the following:

- Texas Instruments, [TPS7H3301-SP Single-Event Effects Summary radiation report](#) (SLAK008)
- Texas Instruments, [TPS7H3301EVM-CVAL \(HREL022\) user's guide](#) (SLVUAK2)

10.3 ドキュメントの更新通知を受け取る方法

ドキュメントの更新についての通知を受け取るには、www.tij.co.jp のデバイス製品フォルダを開いてください。[通知] をクリックして登録すると、変更されたすべての製品情報に関するダイジェストを毎週受け取ることができます。変更の詳細については、改訂されたドキュメントに含まれている改訂履歴をご覧ください。

10.4 サポート・リソース

テキサス・インスツルメンツ E2E™ サポート・フォーラムは、エンジニアが検証済みの回答と設計に関するヒントをエキスパートから迅速かつ直接得ることができる場所です。既存の回答を検索したり、独自の質問をしたりすることで、設計に必要な支援を迅速に得ることができます。

リンクされているコンテンツは、各寄稿者により「現状のまま」提供されるものです。これらはテキサス・インスツルメンツの仕様を構成するものではなく、必ずしもテキサス・インスツルメンツの見解を反映したものではありません。テキサス・インスツルメンツの[使用条件](#)を参照してください。

10.5 Trademarks

テキサス・インスツルメンツ E2E™ is a trademark of Texas Instruments.
すべての商標は、それぞれの所有者に帰属します。

10.6 静電気放電に関する注意事項



この IC は、ESD によって破損する可能性があります。テキサス・インスツルメンツは、IC を取り扱う際には常に適切な注意を払うことを推奨します。正しい取り扱いおよび設置手順に従わない場合、デバイスを破損するおそれがあります。

ESD による破損は、わずかな性能低下からデバイスの完全な故障まで多岐にわたります。精密な IC の場合、パラメータがわずかに変化するだけで公表されている仕様から外れる可能性があるため、破損が発生しやすくなっています。

10.7 用語集

[テキサス・インスツルメンツ用語集](#) この用語集には、用語や略語の一覧および定義が記載されています。

Mechanical, Packaging, and Orderable Information

The following pages include mechanical, packaging, and orderable information. This information is the most current data available for the designated devices. This data is subject to change without notice and revision of this document. For browser-based versions of this data sheet, refer to the left-hand navigation.

重要なお知らせと免責事項

テキサス・インスツルメンツは、技術データと信頼性データ (データシートを含みます)、設計リソース (リファレンス デザインを含みます)、アプリケーションや設計に関する各種アドバイス、Web ツール、安全性情報、その他のリソースを、欠陥が存在する可能性のある「現状のまま」提供しており、商品性および特定目的に対する適合性の黙示保証、第三者の知的財産権の非侵害保証を含むいかなる保証も、明示的または黙示的にかかわらず拒否します。

これらのリソースは、テキサス・インスツルメンツ製品を使用する設計の経験を積んだ開発者への提供を意図したものです。(1) お客様のアプリケーションに適した テキサス・インスツルメンツ製品の選定、(2) お客様のアプリケーションの設計、検証、試験、(3) お客様のアプリケーションに該当する各種規格や、その他のあらゆる安全性、セキュリティ、規制、または他の要件への確実な適合に関する責任を、お客様のみが単独で負うものとします。

上記の各種リソースは、予告なく変更される可能性があります。これらのリソースは、リソースで説明されている テキサス・インスツルメンツ製品を使用するアプリケーションの開発の目的でのみ、テキサス・インスツルメンツはその使用をお客様に許諾します。これらのリソースに関して、他の目的で複製することや掲載することは禁止されています。テキサス・インスツルメンツや第三者の知的財産権のライセンスが付与されている訳ではありません。お客様は、これらのリソースを自身で使用した結果発生するあらゆる申し立て、損害、費用、損失、責任について、テキサス・インスツルメンツおよびその代理人を完全に補償するものとし、テキサス・インスツルメンツは一切の責任を拒否します。

テキサス・インスツルメンツの製品は、[テキサス・インスツルメンツの販売条件](#)、または [ti.com](https://www.ti.com) やかかる テキサス・インスツルメンツ製品の関連資料などのいずれかを通じて提供する適用可能な条項の下で提供されています。テキサス・インスツルメンツがこれらのリソースを提供することは、適用されるテキサス・インスツルメンツの保証または他の保証の放棄の拡大や変更を意味するものではありません。

お客様がいかなる追加条項または代替条項を提案した場合でも、テキサス・インスツルメンツはそれらに異議を唱え、拒否します。

郵送先住所: Texas Instruments, Post Office Box 655303, Dallas, Texas 75265

Copyright © 2024, Texas Instruments Incorporated

PACKAGING INFORMATION

Orderable Device	Status (1)	Package Type	Package Drawing	Pins	Package Qty	Eco Plan (2)	Lead finish/ Ball material (6)	MSL Peak Temp (3)	Op Temp (°C)	Device Marking (4/5)	Samples
5962-1422801VXC	ACTIVE	CFP	HKR	16	25	RoHS-Exempt & Green	Call TI	N / A for Pkg Type	-55 to 125	5962-1422801VXC TPS7H3301-SP	Samples
5962R1422801VXC	ACTIVE	CFP	HKR	16	25	RoHS-Exempt & Green	Call TI	N / A for Pkg Type	-55 to 125	5962R1422801VXC TPS7H3301-RHA	Samples
TPS7H3301HKR/EM	ACTIVE	CFP	HKR	16	25	Non-RoHS & Non-Green	Call TI	N / A for Pkg Type	25 to 25	TPS7H3301HKREM	Samples

(1) The marketing status values are defined as follows:

ACTIVE: Product device recommended for new designs.

LIFEBUY: TI has announced that the device will be discontinued, and a lifetime-buy period is in effect.

NRND: Not recommended for new designs. Device is in production to support existing customers, but TI does not recommend using this part in a new design.

PREVIEW: Device has been announced but is not in production. Samples may or may not be available.

OBSOLETE: TI has discontinued the production of the device.

(2) **RoHS:** TI defines "RoHS" to mean semiconductor products that are compliant with the current EU RoHS requirements for all 10 RoHS substances, including the requirement that RoHS substance do not exceed 0.1% by weight in homogeneous materials. Where designed to be soldered at high temperatures, "RoHS" products are suitable for use in specified lead-free processes. TI may reference these types of products as "Pb-Free".

RoHS Exempt: TI defines "RoHS Exempt" to mean products that contain lead but are compliant with EU RoHS pursuant to a specific EU RoHS exemption.

Green: TI defines "Green" to mean the content of Chlorine (Cl) and Bromine (Br) based flame retardants meet JS709B low halogen requirements of <=1000ppm threshold. Antimony trioxide based flame retardants must also meet the <=1000ppm threshold requirement.

(3) MSL, Peak Temp. - The Moisture Sensitivity Level rating according to the JEDEC industry standard classifications, and peak solder temperature.

(4) There may be additional marking, which relates to the logo, the lot trace code information, or the environmental category on the device.

(5) Multiple Device Markings will be inside parentheses. Only one Device Marking contained in parentheses and separated by a "~" will appear on a device. If a line is indented then it is a continuation of the previous line and the two combined represent the entire Device Marking for that device.

(6) Lead finish/Ball material - Orderable Devices may have multiple material finish options. Finish options are separated by a vertical ruled line. Lead finish/Ball material values may wrap to two lines if the finish value exceeds the maximum column width.

Important Information and Disclaimer:The information provided on this page represents TI's knowledge and belief as of the date that it is provided. TI bases its knowledge and belief on information provided by third parties, and makes no representation or warranty as to the accuracy of such information. Efforts are underway to better integrate information from third parties. TI has taken and continues to take reasonable steps to provide representative and accurate information but may not have conducted destructive testing or chemical analysis on incoming materials and chemicals. TI and TI suppliers consider certain information to be proprietary, and thus CAS numbers and other limited information may not be available for release.

In no event shall TI's liability arising out of such information exceed the total purchase price of the TI part(s) at issue in this document sold by TI to Customer on an annual basis.

TUBE

*All dimensions are nominal

Device	Package Name	Package Type	Pins	SPQ	L (mm)	W (mm)	T (μm)	B (mm)
5962-1422801VXC	HKR	CFP	16	25	506.98	26.16	6220	NA
5962R1422801VXC	HKR	CFP	16	25	506.98	26.16	6220	NA
TPS7H3301HKR/EM	HKR	CFP	16	25	506.98	26.16	6220	NA

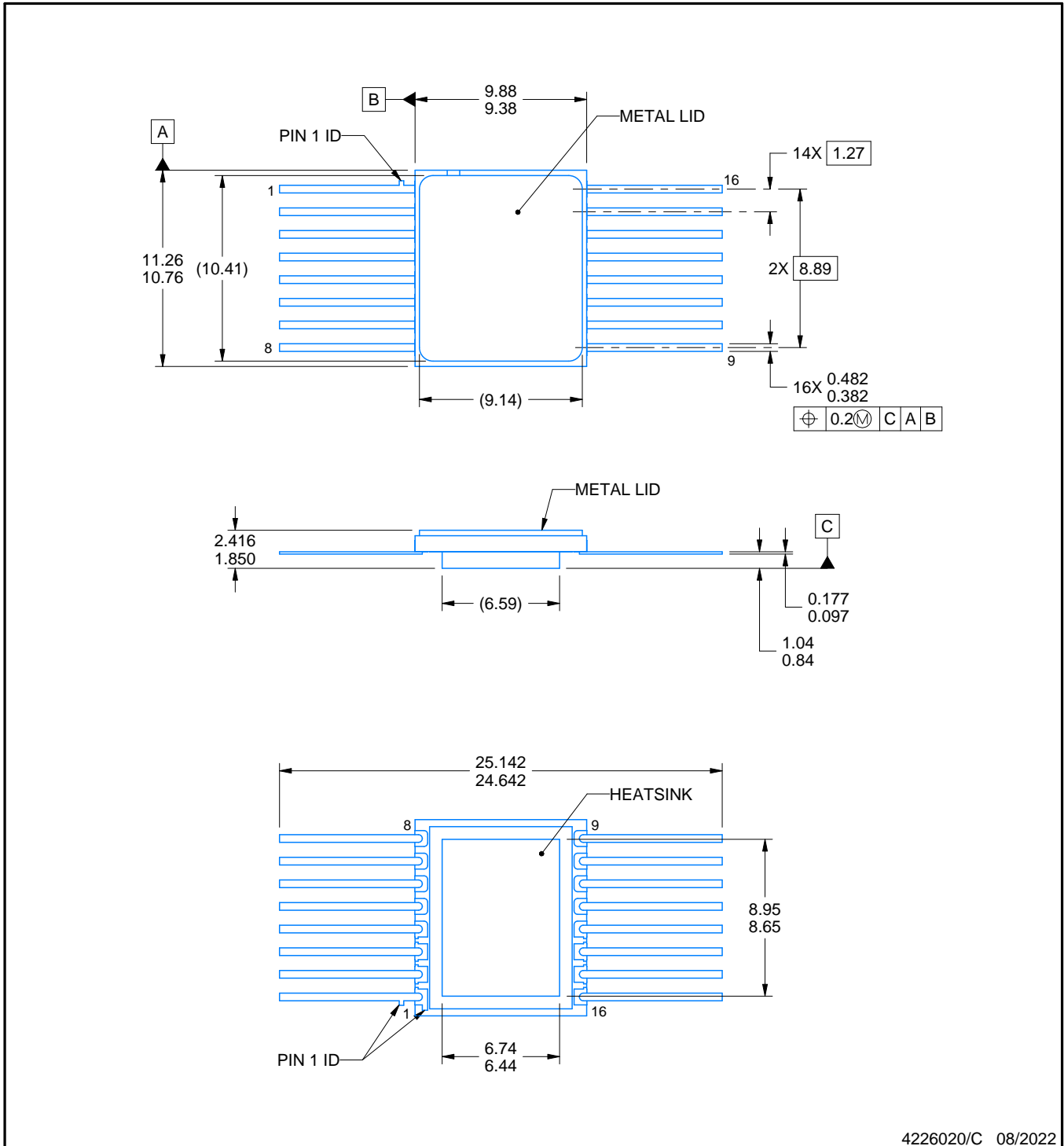
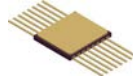

4226020/C 08/2022

NOTES:

1. All linear dimensions are in millimeters. Any dimensions in parenthesis are for reference only. Dimensioning and tolerancing per ASME Y14.5M.
2. This drawing is subject to change without notice.
3. This package is hermetically sealed with a metal lid. Lid is connected to Heatsink.
4. The terminals are gold plated.
5. Falls within MIL-STD-1835 CDFP-F11A.

EXAMPLE BOARD LAYOUT

HKR0016A

CFP - 2.416 mm max height

CERAMIC DUAL FLATPACK

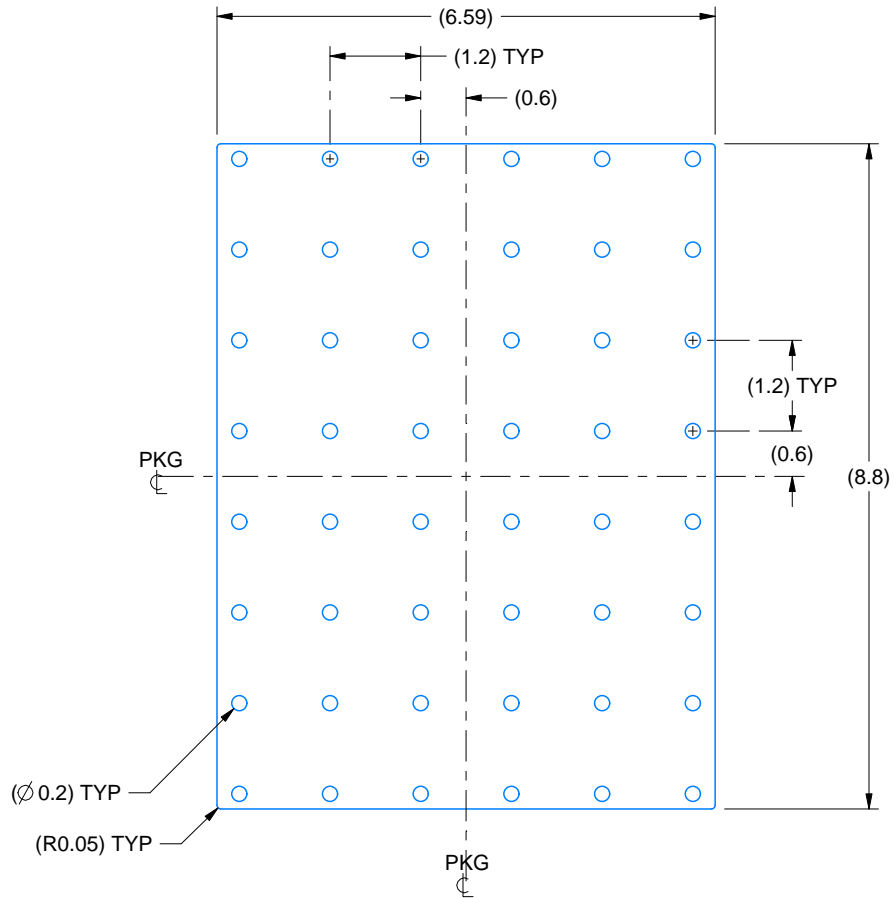

HEATSINK LAND PATTERN EXAMPLE
EXPOSED METAL SHOWN
SCALE:10X

4226020/C 08/2022

重要なお知らせと免責事項

TI は、技術データと信頼性データ(データシートを含みます)、設計リソース(リファレンス・デザインを含みます)、アプリケーションや設計に関する各種アドバイス、Web ツール、安全性情報、その他のリソースを、欠陥が存在する可能性のある「現状のまま」提供しており、商品性および特定目的に対する適合性の黙示保証、第三者の知的財産権の非侵害保証を含むいかなる保証も、明示的または黙示的にかかわらず拒否します。

これらのリソースは、TI 製品を使用する設計の経験を積んだ開発者への提供を意図したものです。(1) お客様のアプリケーションに適した TI 製品の選定、(2) お客様のアプリケーションの設計、検証、試験、(3) お客様のアプリケーションに該当する各種規格や、その他のあらゆる安全性、セキュリティ、規制、または他の要件への確実な適合に関する責任を、お客様のみが単独で負うものとし、

上記の各種リソースは、予告なく変更される可能性があります。これらのリソースは、リソースで説明されている TI 製品を使用するアプリケーションの開発の目的でのみ、TI はその使用をお客様に許諾します。これらのリソースに関して、他の目的で複製することや掲載することは禁止されています。TI や第三者の知的財産権のライセンスが付与されている訳ではありません。お客様は、これらのリソースを自身で使用した結果発生するあらゆる申し立て、損害、費用、損失、責任について、TI およびその代理人を完全に補償するものとし、TI は一切の責任を拒否します。

TI の製品は、[TI の販売条件](#)、または [ti.com](#) やかかる TI 製品の関連資料などのいずれかを通じて提供する適用可能な条項の下で提供されています。TI がこれらのリソースを提供することは、適用される TI の保証または他の保証の放棄の拡大や変更を意味するものではありません。

お客様がいかなる追加条項または代替条項を提案した場合でも、TI はそれらに異議を唱え、拒否します。

郵送先住所 : Texas Instruments, Post Office Box 655303, Dallas, Texas 75265
Copyright © 2024, Texas Instruments Incorporated