

# TPS736-Q1 車載、コンデンサ不要、NMOS、400mA 低ドロップアウトレギュレータ、逆電流保護機能搭載

## 1 特長

- 車載アプリケーション用に AEC-Q100 認定済み:
  - 温度グレード 1:  $-40^{\circ}\text{C} \sim +125^{\circ}\text{C}$ ,  $T_A$
  - デバイス HBM ESD 分類レベル 2
  - デバイス CDM ESD 分類レベル C4B
- 出力コンデンサなし、または任意の値またはタイプのコンデンサで安定動作
- 入力電圧範囲:  $1.7\text{V} \sim 5.5\text{V}$
- 非常に低いドロップアウト電圧:  $75\text{mV}$  (標準値)
- オプションの出力コンデンサの有無にかかわらず非常に優れた負荷過渡応答
- 新しい NMOS トポロジにより、逆リーク電流を低減
- 低ノイズ:  $30\mu\text{V}_{\text{RMS}}$  (標準値,  $10\text{Hz} \sim 100\text{kHz}$ )
- 初期精度:  $0.5\%$
- ライン、負荷、温度の全範囲にわたって  $1\%$  の総合精度
- シャットダウンモードの最大  $I_Q$ :  $1\mu\text{A}$  未満
- サーマル シャットダウン、仕様規定された最小 / 最大電流制限保護
- 複数の出力電圧バージョンが利用可能:
  - 固定出力:  $1.2\text{V} \sim 3.3\text{V}$
  - 調整可能な出力:  $1.2\text{V} \sim 5.5\text{V}$

## 2 アプリケーション

- インフォテインメント
- ADAS
- 車載クラスタ
- 車体制御モジュール

## 3 概要

TPS736-Q1 低ドロップアウト (LDO) リニア電圧レギュレータは、NMOS パストラジスタで構成される NMOS トポロジを電圧フォロウ構成で使用します。このトポロジは、低 ESR の出力コンデンサで安定に動作し、コンデンサを使用しなくても動作できます。また、このトポロジは逆耐圧が高く (低逆電流)、グランドピン電流が全出力電流値にわたってほぼ一定です。

TPS736-Q1 は、非常に低いドロップアウト電圧と小さいグランドピン電流を実現すると同時に、先進の BiCMOS プロセスを使用することで高い精度を達成しています。ディセーブル時の消費電流は  $1\mu\text{A}$  未満であり、携帯型アプリケーションに最適です。非常に小さい出力ノイズ ( $0.1\mu\text{F}$  の  $C_{\text{NR}}$  で  $30\mu\text{V}_{\text{RMS}}$ ) は、VCO への電力供給に最適です。このデバイスは、サーマル シャットダウンとフォールドバック電流制限によって保護されています。

### パッケージ情報

部品番号	パッケージ (1)	パッケージ サイズ (2)
TPS736-Q1	DBV (SOT-23, 5)	$2.9\text{mm} \times 2.8\text{mm}$
	DCQ (SOT-223, 6)	$6.5\text{mm} \times 7.06\text{mm}$

- 詳細については、「メカニカル、パッケージ、および注文情報」を参照してください。
- パッケージサイズ (長さ × 幅) は公称値で、該当する場合はピンも含まれます。

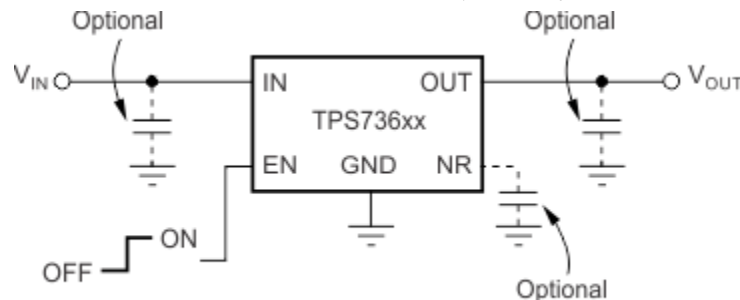

Copyright © 2016, Texas Instruments Incorporated

### 代表的なアプリケーション



## Table of Contents

<b>1 特長</b> .....	<b>1</b>	<b>7 Application and Implementation</b> .....	<b>18</b>
<b>2 アプリケーション</b> .....	<b>1</b>	7.1 Application Information.....	18
<b>3 概要</b> .....	<b>1</b>	7.2 Typical Applications.....	18
<b>4 Pin Configuration and Functions</b> .....	<b>3</b>	7.3 Power Supply Recommendations.....	21
<b>5 Specifications</b> .....	<b>4</b>	7.4 Layout.....	21
5.1 Absolute Maximum Ratings.....	4	<b>8 Device And Documentation Support</b> .....	<b>23</b>
5.2 ESD Ratings.....	4	8.1 Device Support.....	23
5.3 Recommended Operating Conditions.....	4	8.2 ドキュメントの更新通知を受け取る方法.....	23
5.4 Thermal Information.....	4	8.3 サポート・リソース.....	23
5.5 Electrical Characteristics.....	5	8.4 Trademarks.....	23
5.6 Typical Characteristics.....	6	8.5 静電気放電に関する注意事項.....	23
<b>6 Detailed Description</b> .....	<b>15</b>	8.6 用語集.....	23
6.1 Overview.....	15	<b>9 Revision History</b> .....	<b>23</b>
6.2 Functional Block Diagrams.....	15	<b>10 Mechanical, Packaging, And Orderable Information</b> .....	<b>24</b>
6.3 Feature Description.....	16		
6.4 Device Functional Modes.....	17		

## 4 Pin Configuration and Functions



図 4-1. DBV Package, 5-Pin SOT-23 (Top View)



図 4-2. DCQ Package, 6-Pin SOT-223 (Top View)

表 4-1. Pin Functions

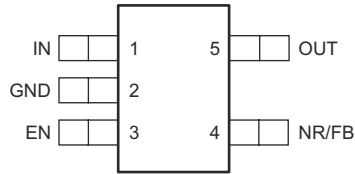
NAME	PIN NO.		I/O	DESCRIPTION
	SOT-23	SOT-223		
EN	3	5	I	Driving the enable pin (EN) high turns on the regulator. Driving this pin low puts the regulator into shutdown mode. See the <a href="#">Enable Pin and Shutdown</a> section for more information. EN can be connected to IN if not used.
FB	4	4	I	FB pin for adjustable voltage version only—this is the input to the control loop error amplifier, and is used to set the output voltage of the device.
GND	2	3, 6	—	Ground
IN	1	1	I	Input supply
NR	4	4	—	NR pin for fixed voltage versions only—connecting an external capacitor to this pin bypasses noise generated by the internal band gap, reducing output noise to very low levels.
OUT	5	2	O	Output of the regulator. There are no output capacitor requirements for stability.

## 5 Specifications

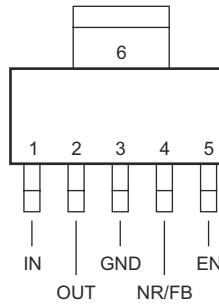
### 5.1 Absolute Maximum Ratings

over operating junction temperature range (unless otherwise noted)<sup>(1)</sup>

		MIN	MAX	UNIT
Voltage	Input, $V_{IN}$	-0.3	6	V
	Enable, $V_{EN}$	-0.3	6	
	Output, $V_{OUT}$	-0.3	5.5	
	$V_{NR}$ , $V_{FB}$	-0.3	6	
Current	Maximum output, $I_{OUT}$	Internally limited		
Output short-circuit duration		Indefinite		
Continuous total power dissipation	$P_{DISS}$	See <i>Thermal Information</i>		
Temperature	Operating junction, $T_J$	-40	150	°C
	Operating ambient, $T_A$	-40	125	
	Storage, $T_{stg}$	-65	150	

- (1) Operation outside the *Absolute Maximum Ratings* may cause permanent device damage. *Absolute Maximum Ratings* do not imply functional operation of the device at these or any other conditions beyond those listed under *Recommended Operating Conditions*. If used outside the *Recommended Operating Conditions* but within the *Absolute Maximum Ratings*, the device may not be fully functional, and this may affect device reliability, functionality, performance, and shorten the device lifetime.

### 5.2 ESD Ratings

			VALUE	UNIT
$V_{(ESD)}$	Electrostatic discharge	Human-body model (HBM), per AEC Q100-002 <sup>(1)</sup>	±2000	V
		Charged-device model (CDM), per AEC Q100-011	±500	

- (1) AEC Q100-002 indicates that HBM stressing shall be in accordance with the ANSI/ESDA/JEDEC JS-001 specification.

### 5.3 Recommended Operating Conditions

over operating junction temperature range (unless otherwise noted)

		MIN	NOM	MAX	UNIT
$V_{IN}$	Input supply voltage	1.7		5.5	V
$V_{OUT}$	Output voltage	0		5.5	V
$I_{OUT}$	Output current	0		400	mA

### 5.4 Thermal Information

THERMAL METRIC <sup>(1)</sup>		TPS736-Q1 New silicon	TPS736-Q1 Legacy silicon	UNIT
		DCQ (SOT-223)	DBV (SOT-23)	
		6 PINS	5 PINS	
$R_{\theta JA}$	Junction-to-ambient thermal resistance	76	221.9	°C/W
$R_{\theta JC(top)}$	Junction-to-case (top) thermal resistance	46.6	74.9	°C/W
$R_{\theta JB}$	Junction-to-board thermal resistance	18.1	51.9	°C/W
$\Psi_{JT}$	Junction-to-top characterization parameter	8.6	2.8	°C/W
$\Psi_{JB}$	Junction-to-board characterization parameter	17.6	51.1	°C/W

- (1) For more information about traditional and new thermal metrics, see the [Semiconductor and IC Package Thermal Metrics](#) application note.

## 5.5 Electrical Characteristics

Over operating temperature range ( $T_J = -40^\circ\text{C}$  to  $125^\circ\text{C}$ ),  $V_{IN} = V_{OUT(nom)} + 0.5V^{(1)}$ ,  $I_{OUT} = 10\text{mA}$ ,  $V_{EN} = 1.7\text{V}$ , and  $C_{OUT} = 0.1\mu\text{F}$  (unless otherwise noted). Typical values are at  $T_J = 25^\circ\text{C}$

PARAMETER		TEST CONDITIONS		MIN	TYP	MAX	UNIT
$V_{IN}$	Input voltage range <sup>(1) (2)</sup>			1.7		5.5	V
$V_{FB}$	Internal reference (TPS73601)	$T_J = 25^\circ\text{C}$		1.198	1.204	1.210	V
$V_{OUT}$	Output voltage range (TPS73601) <sup>(3)</sup>			$V_{FB}$		5.5 - $V_{DO}$	V
	Accuracy <sup>(1) (4)</sup>	Nominal	$T_J = 25^\circ\text{C}$	-0.5		0.5	%
		over $V_{IN}$ , $I_{OUT}$ , and T		-1	$\pm 0.5$	1	
$\Delta V_{OUT(\Delta V_{IN})}$	Line regulation <sup>(1)</sup>	$V_{OUT(nom)} + 0.5\text{V} \leq V_{IN} \leq 5.5\text{V}$			0.01		%/V
$\Delta V_{OUT(\Delta I_{OUT})}$	Load regulation	$1\text{mA} \leq I_{OUT} \leq 400\text{mA}$			0.002		%/mA
		$10\text{mA} \leq I_{OUT} \leq 400\text{mA}$			0.0005		
$V_{DO}$	Dropout voltage <sup>(5)</sup> ( $V_{IN} = V_{OUT(nom)} - 0.1\text{V}$ )	$I_{OUT} = 400\text{mA}$			75	200	mV
$Z_{O(DO)}$	Output impedance in dropout	$1.7\text{V} \leq V_{IN} \leq V_{OUT} + V_{DO}$			0.25		$\Omega$
$I_{CL}$	Output current limit	$V_{OUT} = 0.9 \times V_{OUT(nom)}$	legacy silicon	400	650	800	mA
		$3.6\text{V} \leq V_{IN} \leq 4.2\text{V}$ , $0^\circ\text{C} \leq T_J \leq 70^\circ\text{C}$		500		800	
		$V_{OUT} = 0.9 \times V_{OUT(nom)}$	new silicon	500		800	
$I_{SC}$	Short-circuit current	$V_{OUT} = 0\text{V}$			450		mA
$I_{REV}$	Reverse leakage current <sup>(6)</sup> ( $-I_{IN}$ )	$V_{EN} \leq 0.5\text{V}$ , $0\text{V} \leq V_{IN} \leq V_{OUT}$			0.1	10	$\mu\text{A}$
$I_{GND}$	Ground pin current	$I_{OUT} = 10\text{mA}$ ( $I_Q$ )			400	550	$\mu\text{A}$
$I_{GND}$	Ground pin current	$I_{OUT} = 400\text{mA}$			800	1000	$\mu\text{A}$
$I_{SHDN}$	Shutdown current ( $I_{GND}$ )	$V_{EN} \leq 0.5\text{V}$ , $V_{OUT} \leq V_{IN} \leq 5.5\text{V}$ , $-40^\circ\text{C} \leq T_J \leq 100^\circ\text{C}$ , legacy silicon	$V_{EN} \leq 0.5\text{V}$ , $V_{OUT} \leq V_{IN} \leq 5.5\text{V}$ , $-40^\circ\text{C} \leq T_J \leq 100^\circ\text{C}$ , legacy silicon		0.02	1.3	$\mu\text{A}$
$I_{SHDN}$	Shutdown current ( $I_{GND}$ )	$V_{EN} \leq 0.5\text{V}$ , $V_{OUT} \leq V_{IN} \leq 5.5\text{V}$ , new silicon	$V_{EN} \leq 0.5\text{V}$ , $V_{OUT} \leq V_{IN} \leq 5.5\text{V}$ , new silicon		0.02	1	$\mu\text{A}$
$I_{FB}$	Feedback pin current (TPS73601)				0.1	0.45	$\mu\text{A}$
PSRR	Power-supply rejection ratio (ripple rejection)	$f = 100\text{Hz}$ , $I_{OUT} = 400\text{mA}$			58		dB
		$f = 10\text{kHz}$ , $I_{OUT} = 400\text{mA}$			37		
$V_N$	Output noise voltage, BW = 10Hz to 100kHz	$C_{OUT} = 10\mu\text{F}$ , no $C_{NR}$			27 x $V_{OUT}$		$\mu\text{V}_{RMS}$
		$C_{OUT} = 10\mu\text{F}$ , $C_{NR} = 0.01\mu\text{F}$			8.5 x $V_{OUT}$		
$t_{STR}$	Startup time	$V_{OUT} = 3\text{V}$ , $R_L = 30\Omega$ , $C_{OUT} = 1\mu\text{F}$			600		$\mu\text{s}$
$V_{EN(high)}$	EN pin high (enabled)			1.7		$V_{IN}$	V
$V_{EN(low)}$	EN pin low (shutdown)			0		0.5	V
$I_{EN(high)}$	Enable pin current (enabled)	$V_{EN} = 5.5\text{V}$			0.02	0.1	$\mu\text{A}$
$T_{SD}$	Thermal shutdown temperature	Shutdown, temperature increasing			160		$^\circ\text{C}$
		Reset, temperature decreasing			140		

- (1) Minimum  $V_{IN} = V_{OUT} + V_{DO}$  or 1.7V, whichever is greater.
- (2) For  $V_{OUT(nom)} < 1.6\text{V}$ , when  $V_{IN} \leq 1.6\text{V}$ , the output locks to  $V_{IN}$  and may result in a damaging over-voltage condition on the output. To avoid this situation, disable the device before powering down  $V_{IN}$ . (Legacy silicon only)
- (3) TPS73601-Q1 is tested at  $V_{OUT} = 2.5\text{V}$ .
- (4) Tolerance of external resistors not included in this specification.
- (5)  $V_{DO}$  is not measured for output versions with  $V_{OUT(nom)} < 1.8\text{V}$ , because minimum  $V_{IN} = 1.7\text{V}$ .
- (6) Fixed-voltage versions only; refer to *Application Information* section for more information.

### 5.6 Typical Characteristics

for all voltage versions, at  $T_J = 25^\circ\text{C}$ ,  $V_{IN} = V_{OUT(nom)} + 0.5\text{V}$ ,  $I_{OUT} = 10\text{mA}$ ,  $V_{EN} = 1.7\text{V}$ , and  $C_{OUT} = 0.1\mu\text{F}$  (unless otherwise noted)

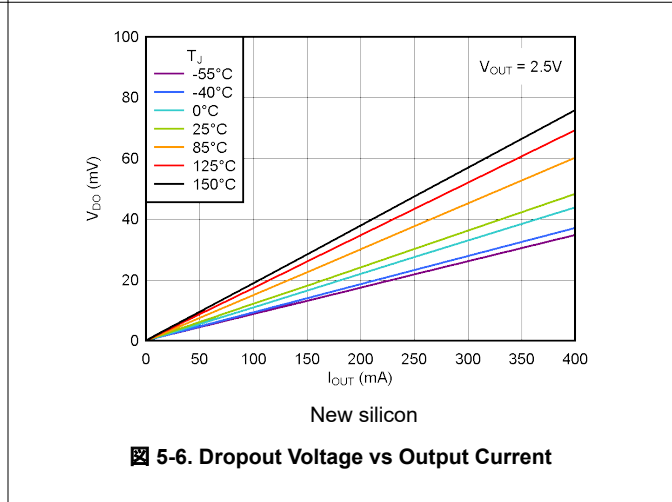
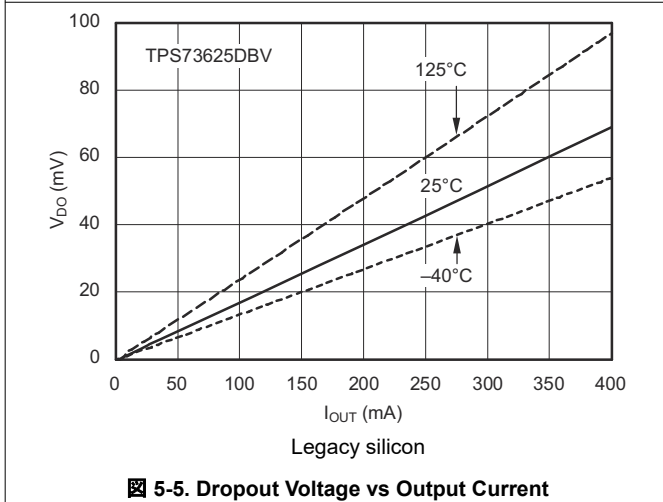
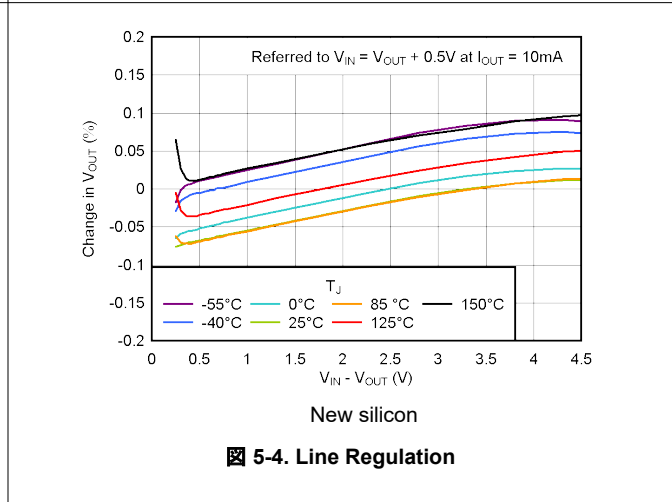
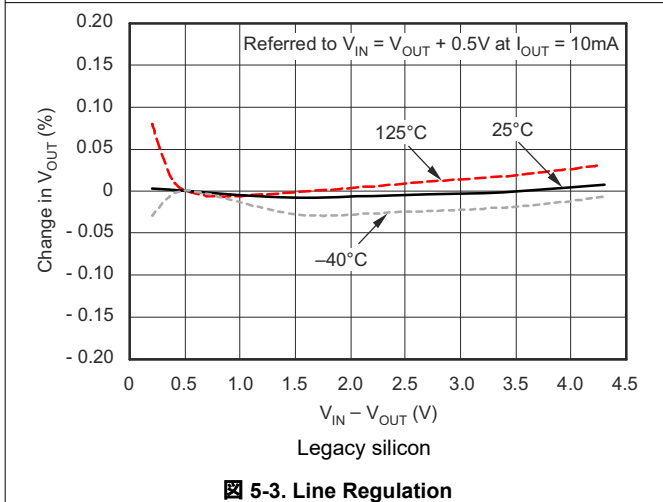
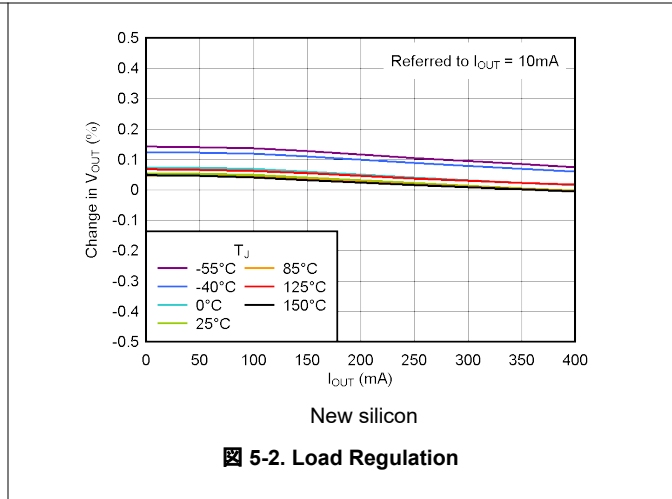
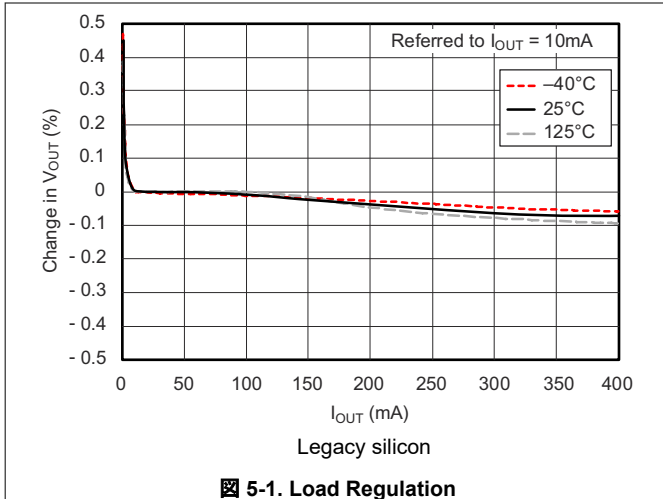

### 5.6 Typical Characteristics (continued)

for all voltage versions, at  $T_J = 25^\circ\text{C}$ ,  $V_{IN} = V_{OUT(nom)} + 0.5\text{V}$ ,  $I_{OUT} = 10\text{mA}$ ,  $V_{EN} = 1.7\text{V}$ , and  $C_{OUT} = 0.1\mu\text{F}$  (unless otherwise noted)

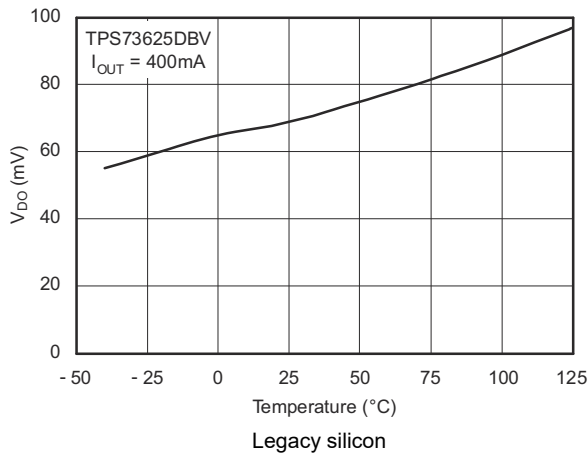

Figure 5-7. Dropout Voltage vs Temperature

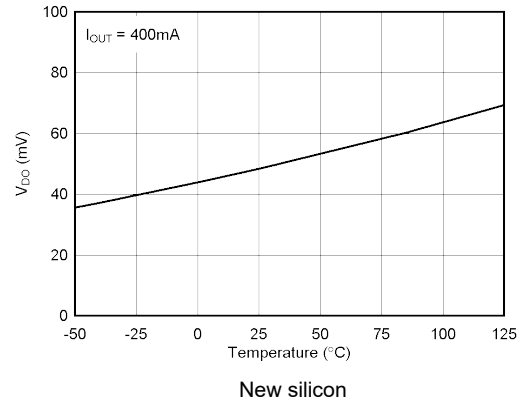

Figure 5-8. Dropout Voltage vs Temperature

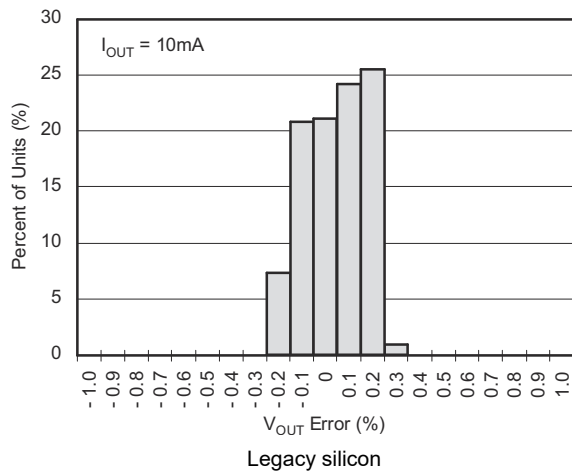

Figure 5-9. Output Voltage Accuracy Histogram

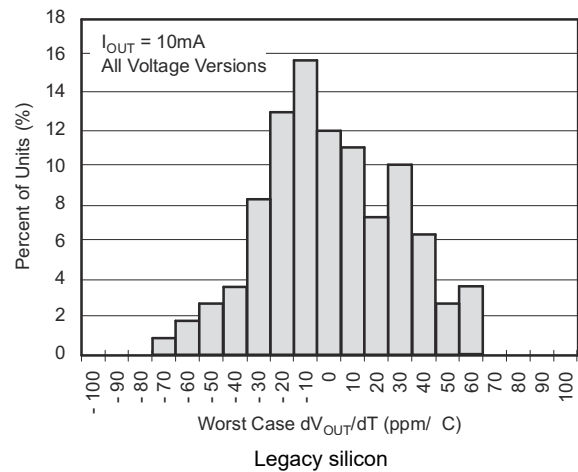

Figure 5-10. Output Voltage Drift Histogram

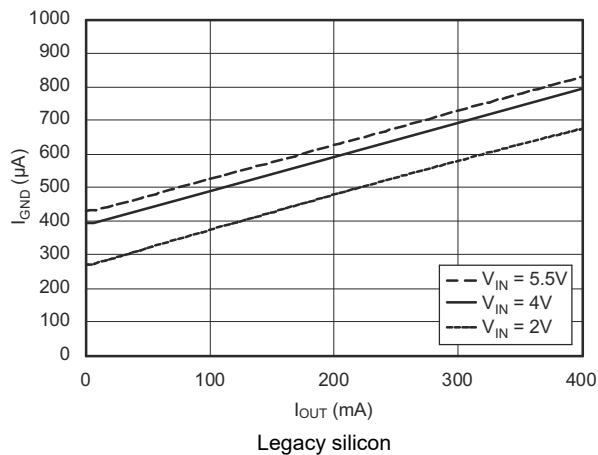

Figure 5-11. Ground Pin Current vs Output Current

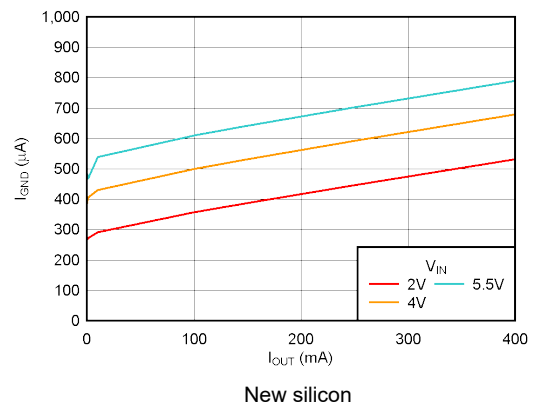

Figure 5-12. Ground Pin Current vs Output Current

### 5.6 Typical Characteristics (continued)

for all voltage versions, at  $T_J = 25^\circ\text{C}$ ,  $V_{IN} = V_{OUT(nom)} + 0.5\text{V}$ ,  $I_{OUT} = 10\text{mA}$ ,  $V_{EN} = 1.7\text{V}$ , and  $C_{OUT} = 0.1\mu\text{F}$  (unless otherwise noted)

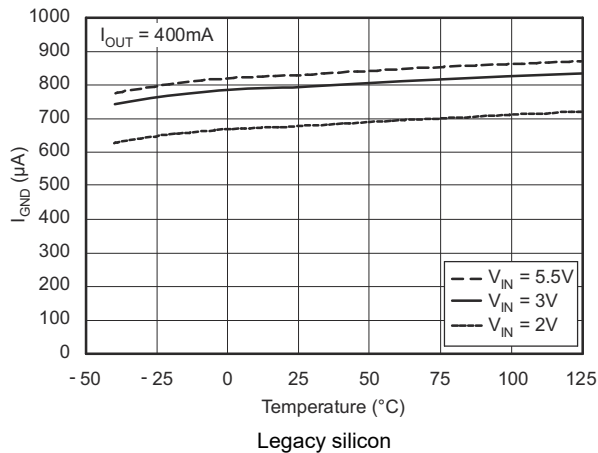

Figure 5-13. Ground Pin Current vs Temperature

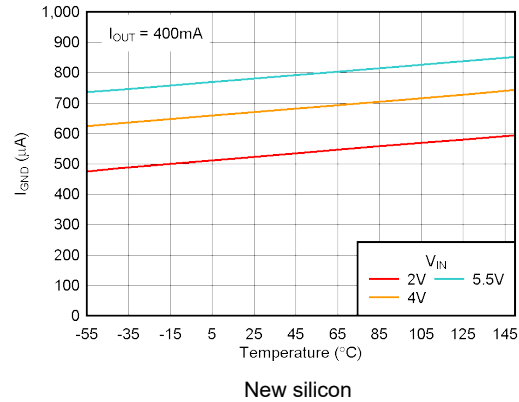

Figure 5-14. Ground Pin Current vs Temperature

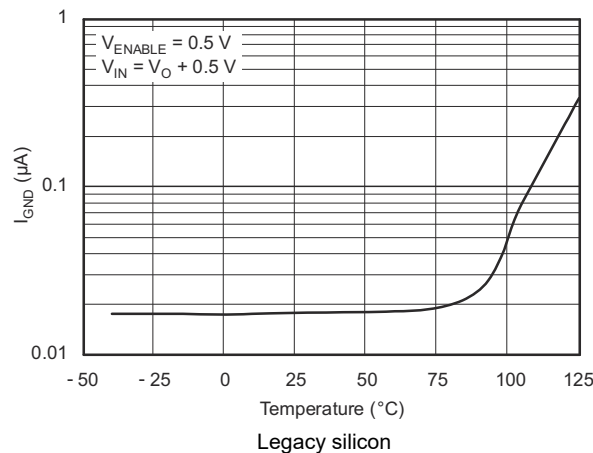

Figure 5-15. Ground Pin Current in Shutdown vs Temperature

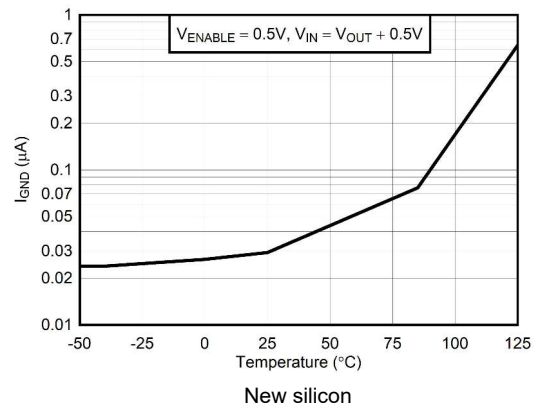

Figure 5-16. Ground Pin Current in Shutdown vs Temperature

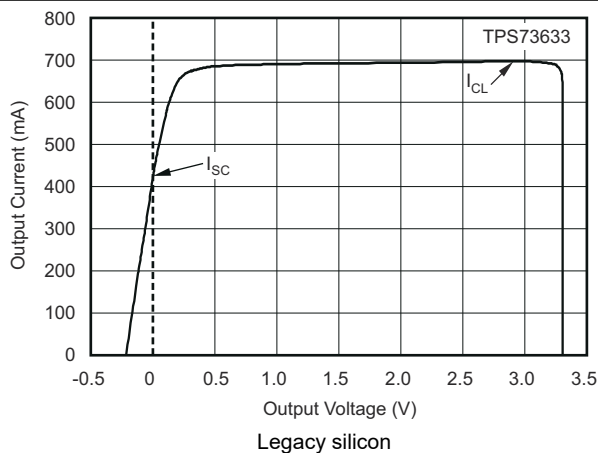

Figure 5-17. Current Limit vs  $V_{OUT}$  (Foldback)

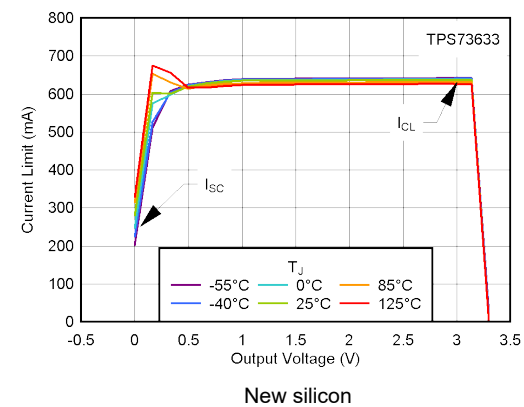
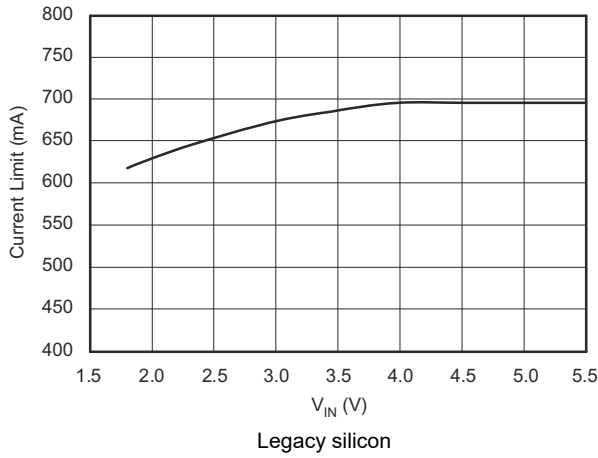

Figure 5-18. Current Limit vs  $V_{OUT}$  (Foldback)



### 5.6 Typical Characteristics (continued)

for all voltage versions, at  $T_J = 25^\circ\text{C}$ ,  $V_{IN} = V_{OUT(\text{nom})} + 0.5\text{V}$ ,  $I_{OUT} = 10\text{mA}$ ,  $V_{EN} = 1.7\text{V}$ , and  $C_{OUT} = 0.1\mu\text{F}$  (unless otherwise noted)



5-19. Current Limit vs  $V_{IN}$

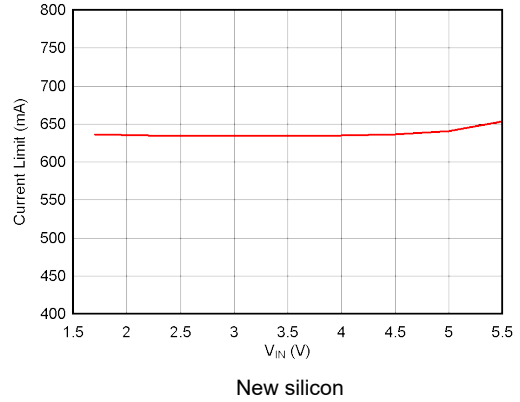

5-20. Current Limit vs  $V_{IN}$

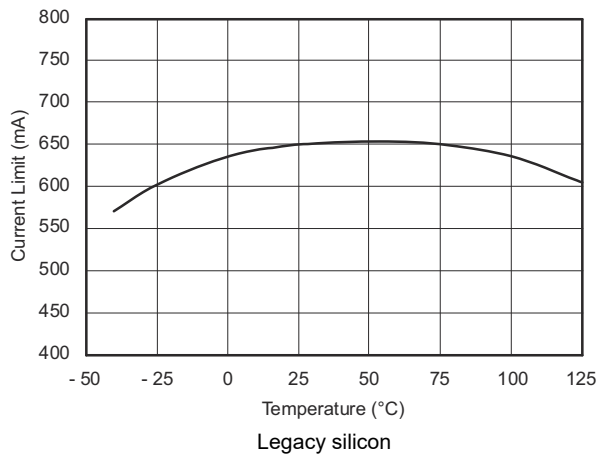

5-21. Current Limit vs Temperature

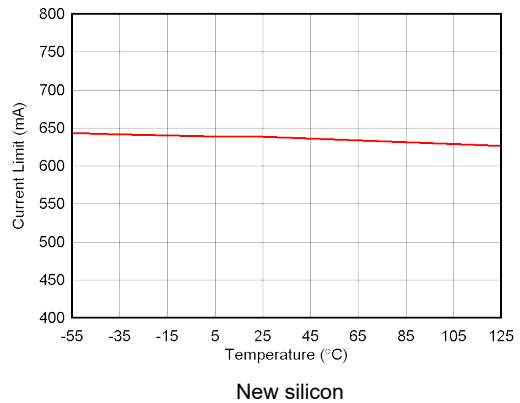

5-22. Current Limit vs Temperature

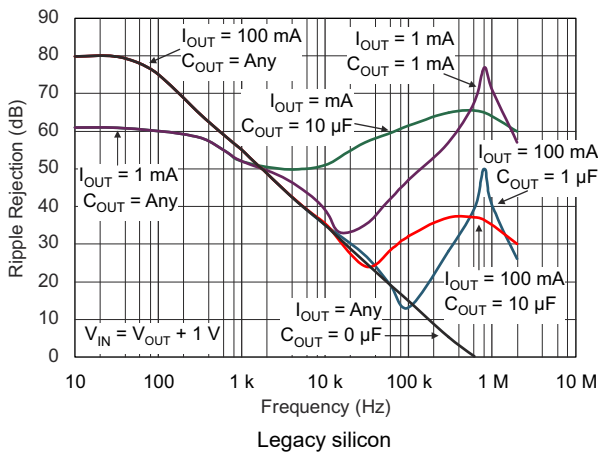

5-23. PSRR (Ripple Rejection) vs Frequency

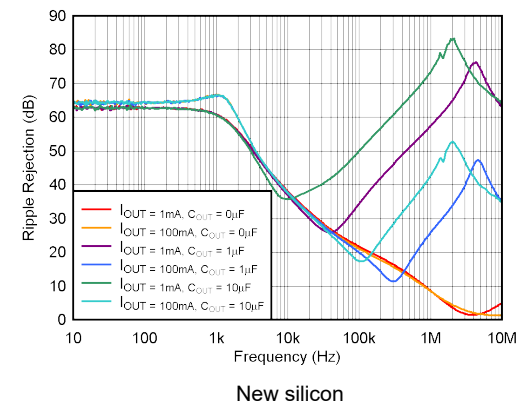

5-24. PSRR (Ripple Rejection) vs Frequency

### 5.6 Typical Characteristics (continued)

for all voltage versions, at  $T_J = 25^\circ\text{C}$ ,  $V_{IN} = V_{OUT(nom)} + 0.5\text{V}$ ,  $I_{OUT} = 10\text{mA}$ ,  $V_{EN} = 1.7\text{V}$ , and  $C_{OUT} = 0.1\mu\text{F}$  (unless otherwise noted)



图 5-25. PSRR (Ripple Rejection) vs  $V_{IN} - V_{OUT}$



图 5-26. PSRR (Ripple Rejection) vs  $(V_{IN} - V_{OUT})$

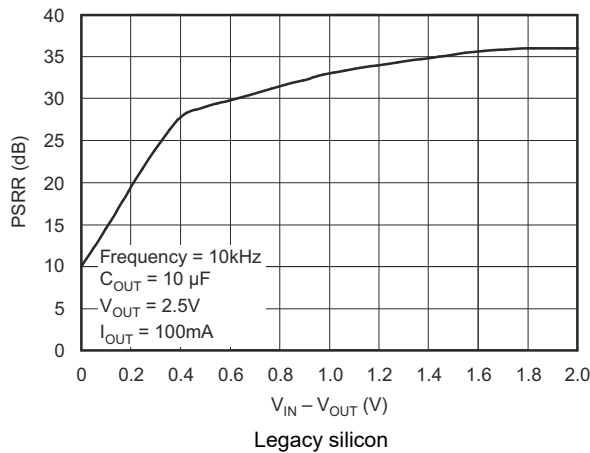

图 5-27. Noise Spectral Density  $C_{NR} = 0\mu\text{F}$

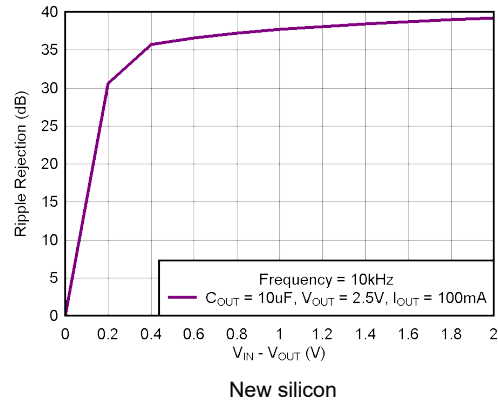

图 5-28. Noise Spectral Density  $C_{NR} = 0\mu\text{F}$

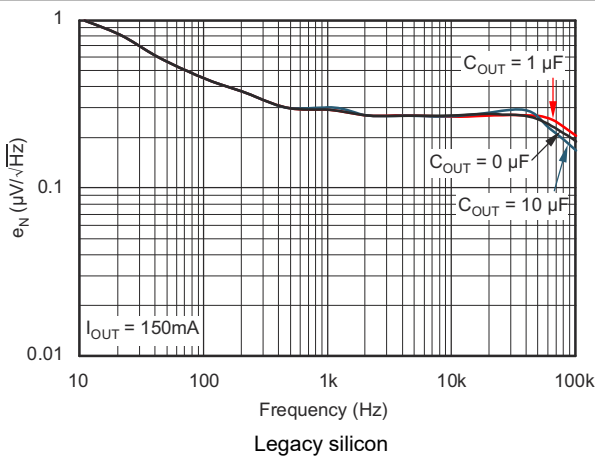

图 5-29. Noise Spectral Density  $C_{NR} = 0.01\mu\text{F}$

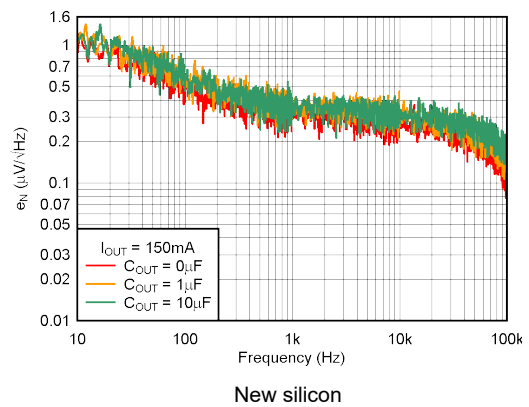

图 5-30. Noise Spectral Density  $C_{NR} = 0.01\mu\text{F}$

### 5.6 Typical Characteristics (continued)

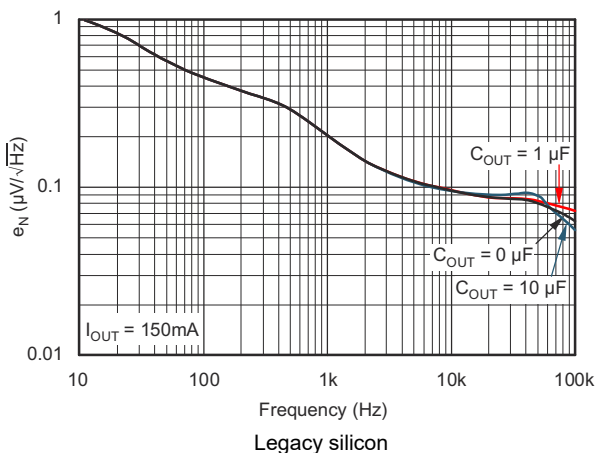
for all voltage versions, at  $T_J = 25^\circ\text{C}$ ,  $V_{IN} = V_{OUT(nom)} + 0.5\text{V}$ ,  $I_{OUT} = 10\text{mA}$ ,  $V_{EN} = 1.7\text{V}$ , and  $C_{OUT} = 0.1\mu\text{F}$  (unless otherwise noted)

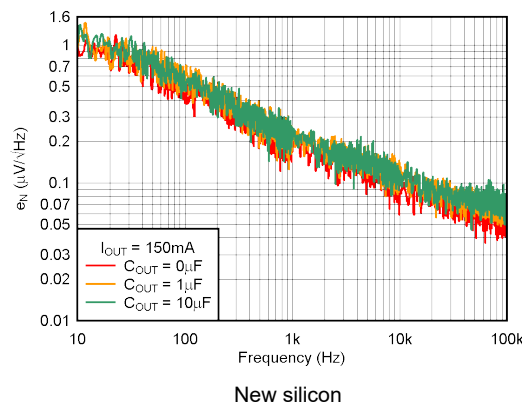
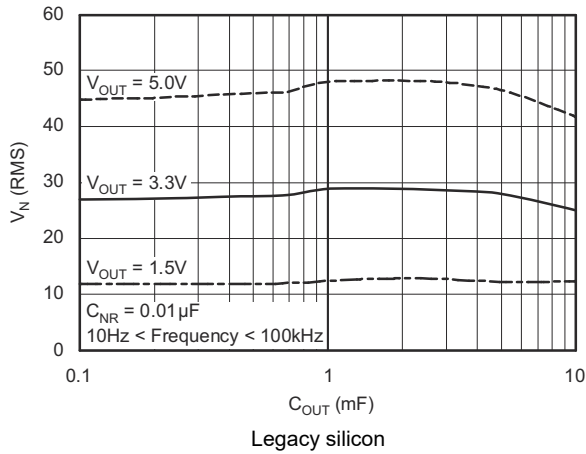

5-31. RMS Noise Voltage vs  $C_{OUT}$

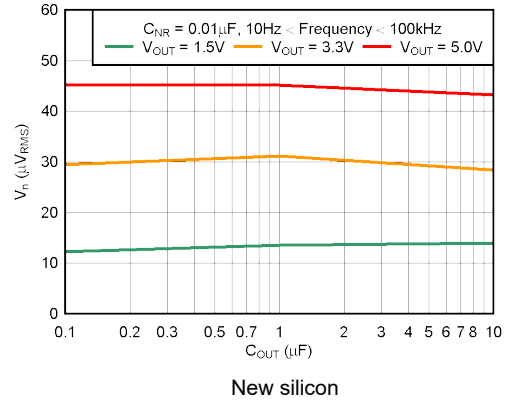

5-32. RMS Noise Voltage vs  $C_{OUT}$

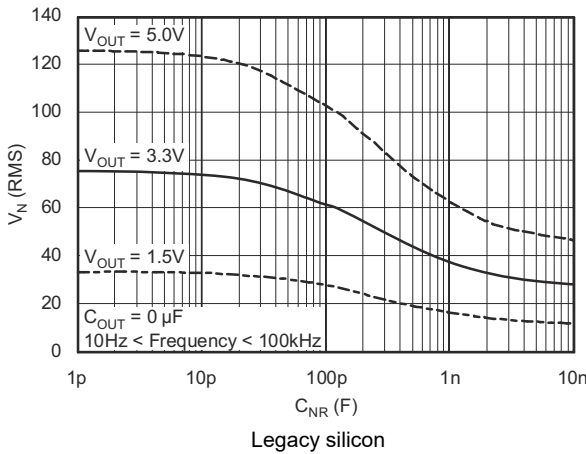

5-33. RMS Noise Voltage vs  $C_{NR}$

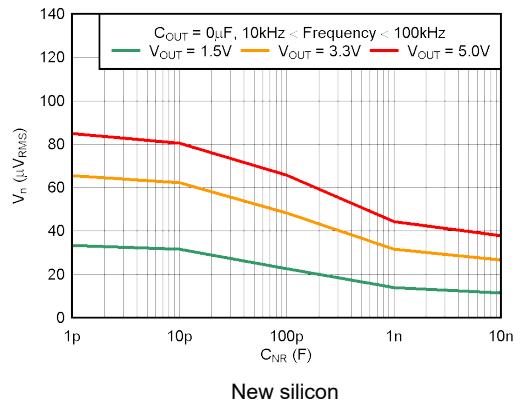

5-34. RMS Noise Voltage vs  $C_{NR}$

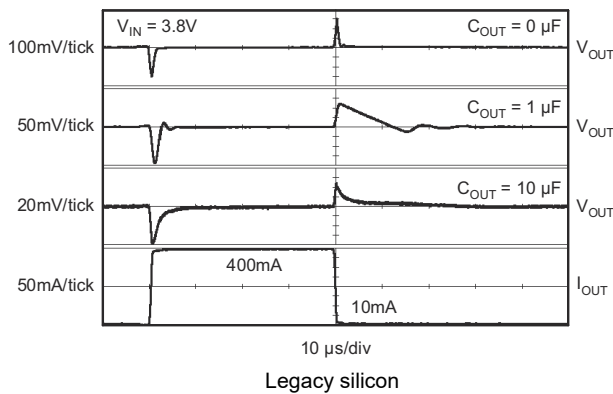

5-35. TPS73633 Load Transient Response

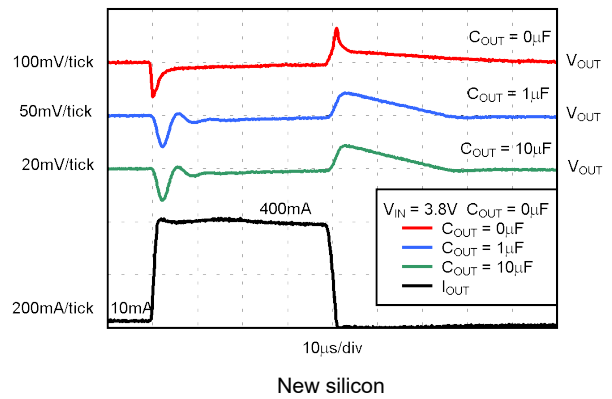

5-36. TPS73633 Load Transient Response

### 5.6 Typical Characteristics (continued)

for all voltage versions, at  $T_J = 25^\circ\text{C}$ ,  $V_{IN} = V_{OUT(\text{nom})} + 0.5\text{V}$ ,  $I_{OUT} = 10\text{mA}$ ,  $V_{EN} = 1.7\text{V}$ , and  $C_{OUT} = 0.1\mu\text{F}$  (unless otherwise noted)

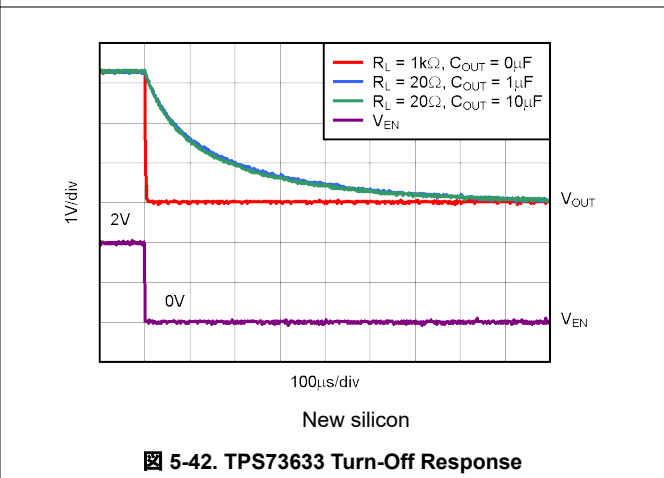
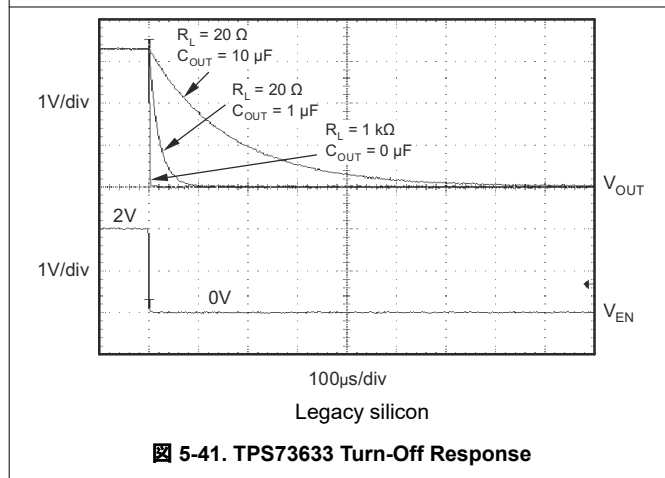
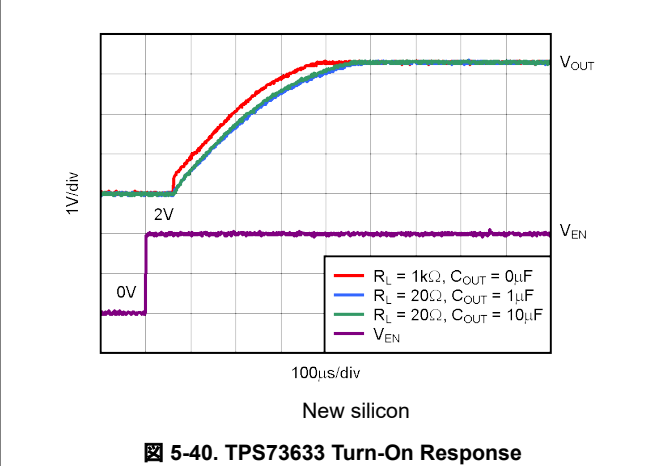
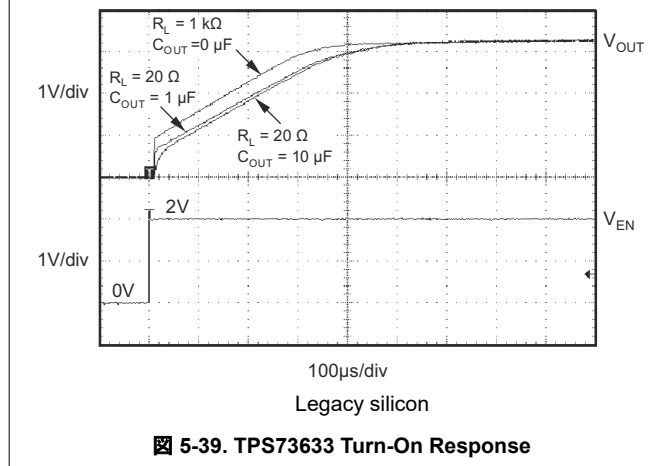
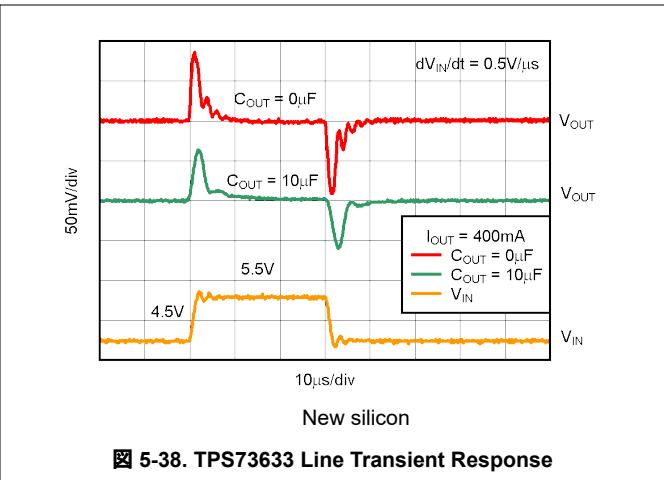
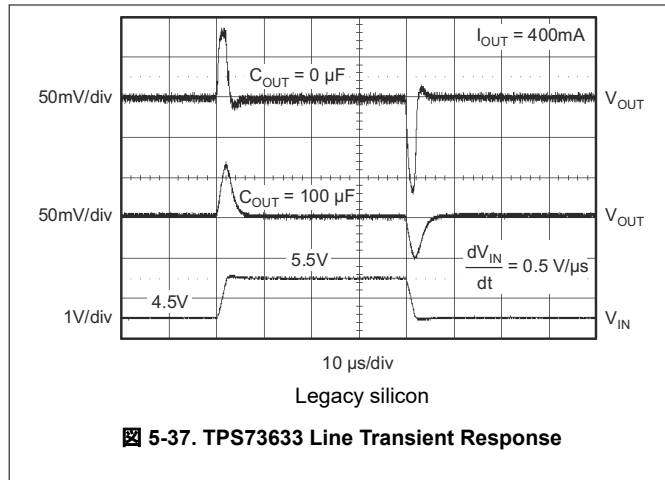

### 5.6 Typical Characteristics (continued)

for all voltage versions, at  $T_J = 25^\circ\text{C}$ ,  $V_{IN} = V_{OUT(nom)} + 0.5\text{V}$ ,  $I_{OUT} = 10\text{mA}$ ,  $V_{EN} = 1.7\text{V}$ , and  $C_{OUT} = 0.1\mu\text{F}$  (unless otherwise noted)

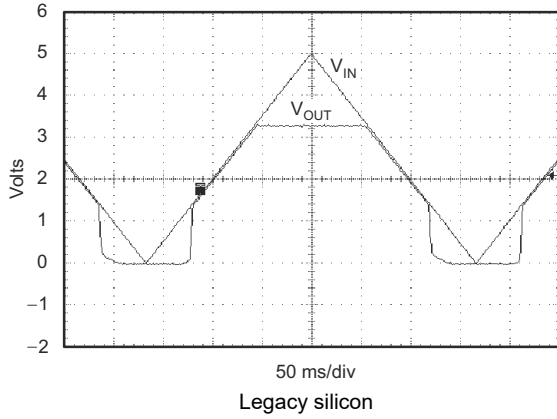

Figure 5-43. TPS73633 Power Up and Power Down

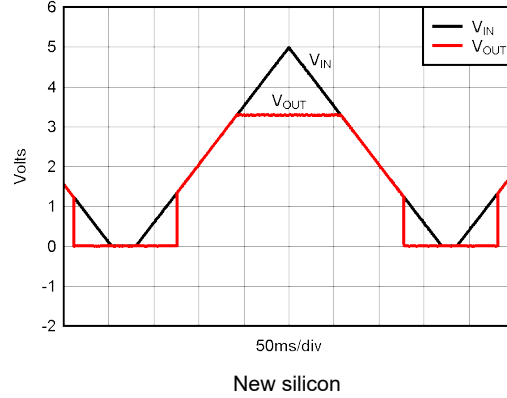

Figure 5-44. TPS73633 Power Up, Power Down

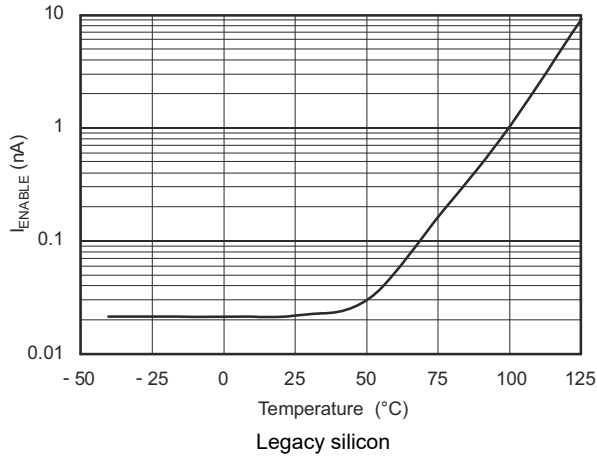

Figure 5-45.  $I_{ENABLE}$  vs Temperature

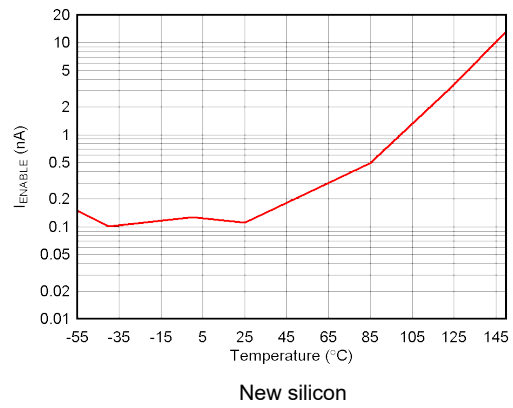

Figure 5-46.  $I_{ENABLE}$  vs Temperature

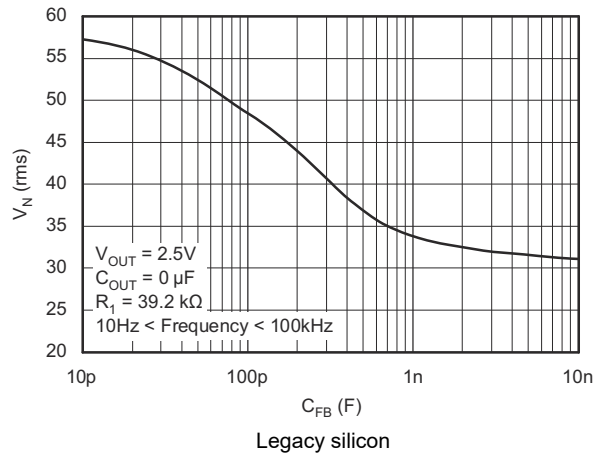

Figure 5-47. TPS73601 RMS Noise Voltage vs  $C_{FB}$

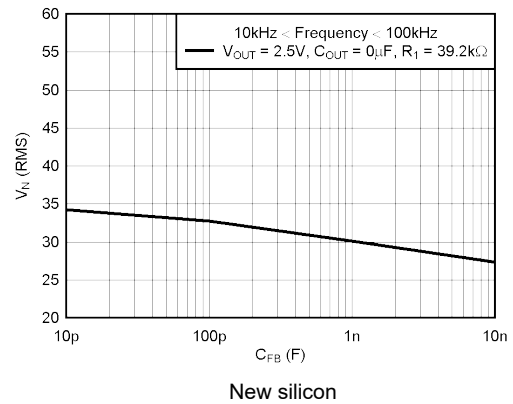
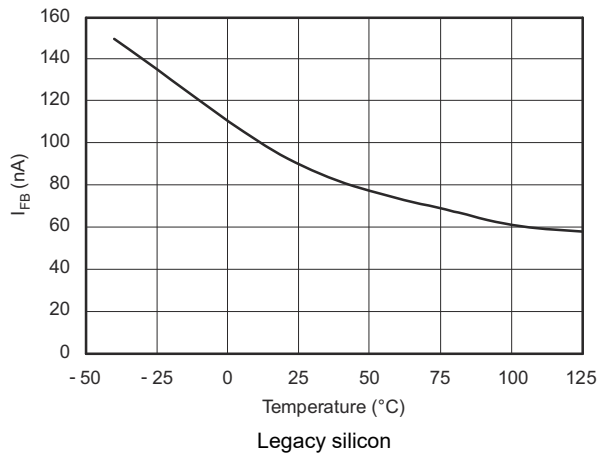

Figure 5-48. TPS73601 RMS Noise Voltage vs  $C_{FB}$

### 5.6 Typical Characteristics (continued)

for all voltage versions, at  $T_J = 25^\circ\text{C}$ ,  $V_{IN} = V_{OUT(nom)} + 0.5\text{V}$ ,  $I_{OUT} = 10\text{mA}$ ,  $V_{EN} = 1.7\text{V}$ , and  $C_{OUT} = 0.1\mu\text{F}$  (unless otherwise noted)



5-49. TPS73601  $I_{FB}$  vs Temperature

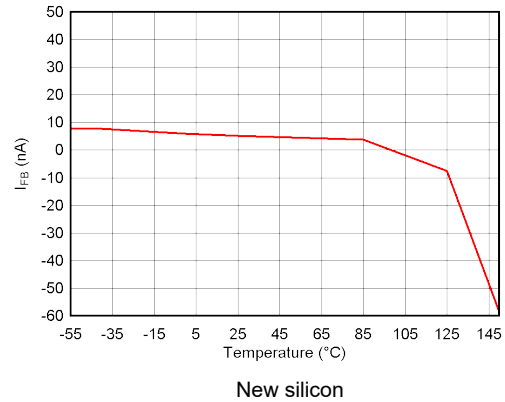

5-50. TPS73601  $I_{FB}$  vs Temperature

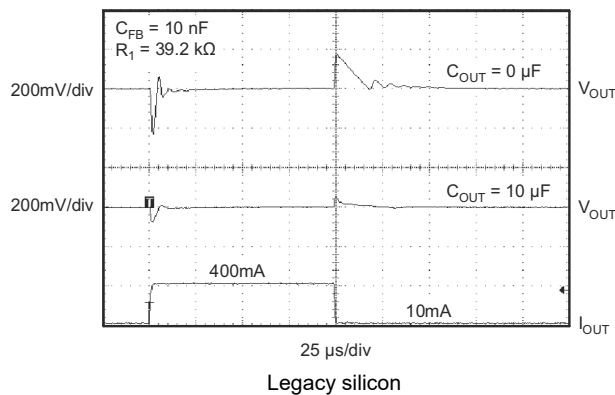

5-51. TPS73601 Load Transient, Adjustable Version

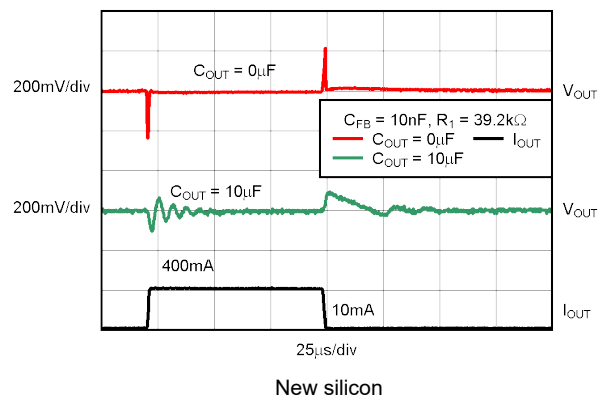

5-52. TPS73601 Load Transient, Adjustable Version

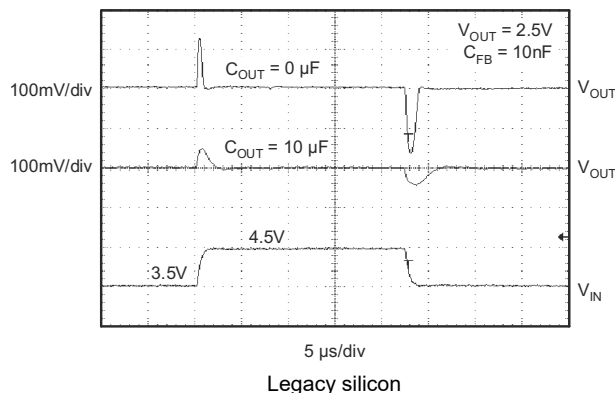

5-53. TPS73601 Line Transient, Adjustable Version

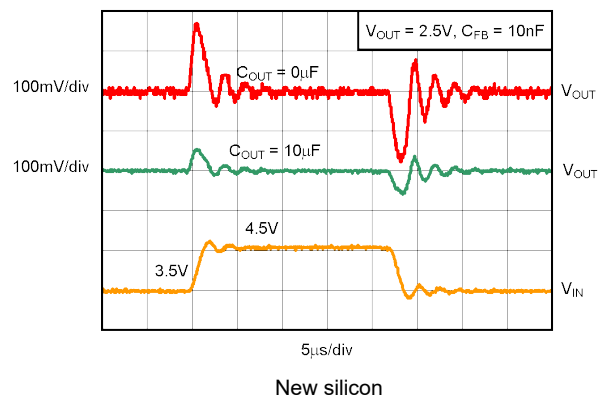

5-54. TPS73601 Line Transient, Adjustable Version

## 6 Detailed Description

### 6.1 Overview

The TPS736xx-Q1 belongs to a family of new-generation LDO regulators that use an NMOS pass transistor to achieve ultra-low dropout performance, reverse current blockage, and freedom from output capacitor constraints. These features, combined with low noise and an enable input, make the TPS736xx-Q1 ideal for portable applications. This regulator family offers a wide selection of fixed output voltage versions and an adjustable output version. All versions have thermal and overcurrent protection, including foldback current limit.

### 6.2 Functional Block Diagrams

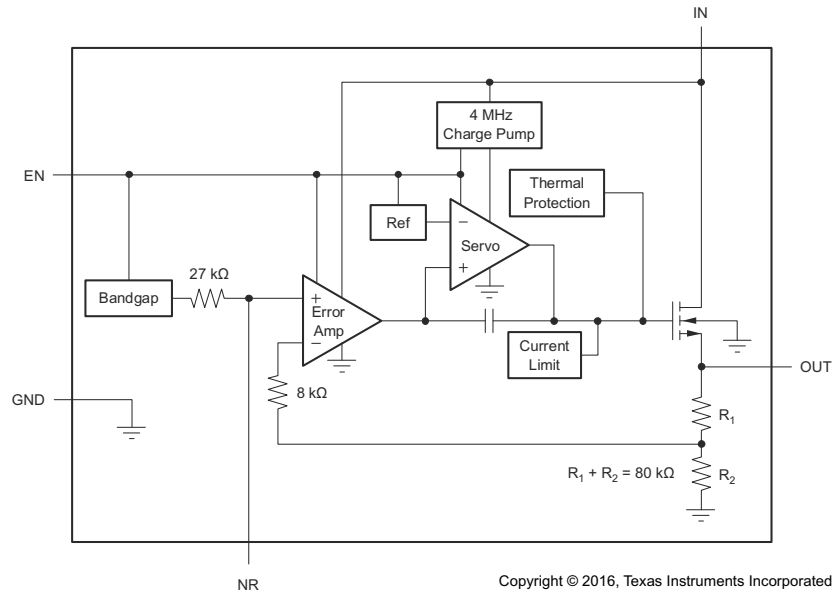

**図 6-1. Fixed Voltage Version**

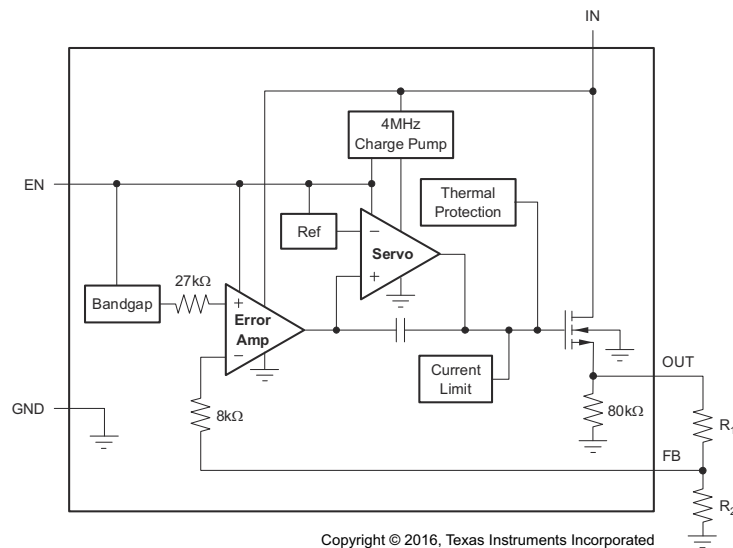

See [表 6-1](#) for standard resistor values.

**図 6-2. Adjustable Voltage Version**

**表 6-1. Standard 1% Resistor Values for Common Output Voltages**

V <sub>OUT</sub> <sup>(1)</sup>	R <sub>1</sub>	R <sub>2</sub>
1.2V	Short	Open
1.5V	23.2kΩ	95.3kΩ
1.8V	28kΩ	56.2kΩ
2.5V	39.2kΩ	36.5kΩ
2.8V	44.2kΩ	33.2kΩ
3V	46.4kΩ	30.9kΩ
3.3V	52.3kΩ	30.1kΩ

(1)  $V_{OUT} = (R_1 + R_2) / R_2 \times 1.204$ ;  $R_1 \parallel R_2 \cong 19k\Omega$  for best accuracy.

## 6.3 Feature Description

### 6.3.1 Internal Current Limit

The TPS736xx-Q1 internal current limit helps protect the regulator during fault conditions. Foldback current limit helps to protect the regulator from damage during output short-circuit conditions by reducing current limit when V<sub>OUT</sub> drops below 0.5 V (see [図 5-17](#)). Approximately –0.2 V of V<sub>OUT</sub> results in a current limit of 0 mA. Therefore, if OUT is forced below –0.2 V before EN goes high, the device may not start up. In applications that work with both a positive and negative voltage supply, the TPS736xx-Q1 must be enabled first.

### 6.3.2 Transient Response

The low open-loop output impedance provided by the NMOS pass element in a voltage follower configuration allows operation without an output capacitor for many applications. As with any regulator, the addition of a capacitor (nominal value of 1 μF) from the OUT pin to ground reduces undershoot magnitude but increase its duration. In the adjustable version, the addition of a capacitor, C<sub>FB</sub>, from the OUT pin to the FB pin also improves the transient response.

The TPS736xx-Q1 does not have active pulldown when the output is overvoltage. This feature allows applications that connect higher voltage sources, such as alternate power supplies, to the output. This feature also results in an output overshoot of several percent if load current quickly drops to zero when a capacitor is connected to the output. The duration of overshoot can be reduced by adding a load resistor. The overshoot decays at a rate determined by output capacitor C<sub>OUT</sub> and the internal and external load resistance. The rate of decay is given by [式 1](#) or [式 2](#), determined by the version.

Fixed voltage version

$$dV / dt = \frac{V_{OUT}}{C_{OUT} \times 80 \text{ k}\Omega \parallel R_{LOAD}} \quad (1)$$

Adjustable voltage version

$$dV / dt = \frac{V_{OUT}}{C_{OUT} \times 80 \text{ k}\Omega \parallel (R_1 + R_2) \parallel R_{LOAD}} \quad (2)$$

### 6.3.3 Reverse Current

The NMOS pass element of the TPS736xx-Q1 provides inherent protection against current flow from the output of the regulator to the input when the gate of the pass device is pulled low. To ensure that all charge is removed from the gate of the pass element, the EN pin must be driven low before the input voltage is removed. If this is not done, the pass element may be left on due to stored charge on the gate.

After the EN pin is driven low, no bias voltage is needed on any pin for reverse current blocking. The reverse current is specified as the current flowing out of the IN pin due to voltage applied on the OUT pin. There is additional current flowing into the OUT pin due to the 80-kΩ internal resistor divider to ground (see [図 6-1](#) and [図 6-2](#)).



For the TPS73601, reverse current may flow when  $V_{FB}$  is more than 1 V above  $V_{IN}$ .

### 6.3.4 Thermal Protection

Thermal protection disables the output when the junction temperature rises to approximately 160°C, allowing the device to cool. When the junction temperature cools to approximately 140°C, the output circuitry is again enabled. Depending on power dissipation, thermal resistance, and ambient temperature, the thermal protection circuit may cycle on and off. Thermal protection limits the dissipation of the regulator, protecting it from damage due to overheating.

Any tendency to activate the thermal protection circuit indicates excessive power dissipation or an inadequate heat sink. For reliable operation, junction temperature must be limited to 125°C maximum. To estimate the margin of safety in a complete design (including heat sink), increase the ambient temperature until the thermal protection is triggered; use worst-case loads and signal conditions. For good reliability, thermal protection must trigger at least 35°C above the maximum expected ambient condition of your application. This application condition produces a worst-case junction temperature of 125°C at the highest expected ambient temperature and worst-case load.

The internal protection circuitry of the TPS736xx-Q1 has been designed to protect against overload conditions. Thermal protection was not intended to replace proper heat sinking. Continuously running the TPS736xx-Q1 into thermal shutdown degrades device reliability.

## 6.4 Device Functional Modes

### 6.4.1 Enable Pin and Shutdown

The enable pin (EN) is active high and is compatible with standard TTL-CMOS levels. A  $V_{EN}$  below 0.5V (maximum) turns the regulator off and drops the GND pin current to approximately 10nA. When EN is used to shutdown the regulator, all charge is removed from the pass transistor gate. A  $V_{EN}$  above 1.7V (minimum) turns the regulator on and the output ramps back up to a regulated  $V_{OUT}$  (see [Figure 5-39](#)).

When shutdown capability is not required, EN can be connected to  $V_{IN}$ . However, the pass gate may not be discharged using this configuration, and the pass transistor may be left on (enhanced) for a significant time after  $V_{IN}$  has been removed. This scenario can result in reverse current flow (if the IN pin is low impedance) and faster ramp times upon power-up. In addition, for  $V_{IN}$  ramp times slower than a few milliseconds, the output may overshoot upon power-up.

Current limit foldback can prevent device start-up under some conditions. See the [Internal Current Limit](#) section for more information.

### 6.4.2 Dropout Voltage

The TPS736xx-Q1 uses an NMOS pass transistor to achieve extremely low dropout. When  $(V_{IN} - V_{OUT})$  is less than the dropout voltage ( $V_{DO}$ ), the NMOS pass device is in its linear region of operation and the input-to-output resistance is the  $R_{DS(ON)}$  of the NMOS pass element.

For large step changes in load current, the TPS736xx-Q1 requires a larger voltage drop from  $V_{IN}$  to  $V_{OUT}$  to avoid degraded transient response. The boundary of this transient dropout region is approximately twice the DC dropout. Values of  $V_{IN} - V_{OUT}$  above this line ensure normal transient response.

Operating in the transient dropout region can cause an increase in recovery time. The time required to recover from a load transient is a function of the magnitude of the change in load current rate, the rate of change in load current, and the available headroom ( $V_{IN}$  to  $V_{OUT}$  voltage drop). Under worst-case conditions [full-scale instantaneous load change with  $(V_{IN} - V_{OUT})$  close to DC dropout levels], the TPS736xx-Q1 can take a couple of hundred microseconds to return to the specified regulation accuracy.

## 7 Application and Implementation

### 注

以下のアプリケーション情報は、TI の製品仕様に含まれるものではなく、TI ではその正確性または完全性を保証いたしません。個々の目的に対する製品の適合性については、お客様の責任で判断していただくこととなります。お客様は自身の設計実装を検証しテストすることで、システムの機能を確認する必要があります。

### 7.1 Application Information

$R_1$  and  $R_2$  can be calculated for any output voltage using the formula shown in [図 7-6](#). Sample resistor values for common output voltages are illustrated in [図 6-2](#).

For best accuracy, make the parallel combination of  $R_1$  and  $R_2$  approximately equal to 19 k $\Omega$ . This 19 k $\Omega$ , in addition to the internal 8-k $\Omega$  resistor, presents the same impedance to the error amp as the 27-k $\Omega$  band-gap reference output. This impedance helps compensate for leakages into the error amp terminals.

### 7.2 Typical Applications

#### 7.2.1 Typical Application Circuit for Fixed-Voltage Versions

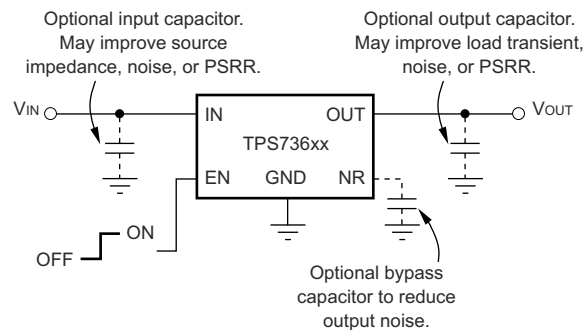

Copyright © 2016, Texas Instruments Incorporated

**図 7-1. Typical Application Circuit for Fixed-Voltage Versions**

#### 7.2.1.1 Design Requirements

For this design example, use the parameters listed in [表 7-1](#) as the input parameters.

**表 7-1. Design Parameters (Fixed-Voltage Version)**

PARAMETER	EXAMPLE VALUE
Input voltage	5 V, $\pm 3\%$
Output voltage	3.3 V, $\pm 1\%$
Output current	400mA (maximum), 20mA (minimum)
RMS noise, 10 Hz to 100 kHz	< 30 $\mu$ V <sub>RMS</sub>
Ambient temperature	55°C (maximum)

#### 7.2.1.2 Detailed Design Procedure

##### 7.2.1.2.1 Input And Output Capacitor Requirements

Although an input capacitor is not required for stability, it is good analog design practice to connect a 0.1 $\mu$ F to 1 $\mu$ F low ESR capacitor across the input supply near the regulator. The input capacitor counteracts reactive input sources and improves transient response, noise rejection, and ripple rejection. A higher-value capacitor may be necessary if large, fast rise-time load transients are anticipated or the device is located several inches from the power source.

The TPS736xx-Q1 does not require an output capacitor for stability and has maximum phase margin with no capacitor. This regulator is designed to be stable for all available types and values of capacitors. In applications where multiple low ESR capacitors are in parallel, ringing may occur when the product of  $C_{OUT}$  and total ESR drops below  $50\text{nF}\cdot\Omega$ . Total ESR includes all parasitic resistances, including capacitor ESR and board, socket, and solder joint resistance. In most applications, the sum of capacitor ESR and trace resistance meets this requirement.

#### 7.2.1.2.2 Output Noise

A precision band-gap reference is used to generate the internal reference voltage,  $V_{REF}$ . This reference is the dominant noise source within the TPS736xx-Q1 and it generates approximately  $32\mu\text{V}_{RMS}$  (10Hz to 100kHz) at the reference output (NR). The regulator control loop gains up the reference noise with the same gain as the reference voltage, so that the noise voltage of the regulator is approximately given by 式 3.

$$V_N = 32\mu\text{V}_{RMS} \times \frac{(R_1 + R_2)}{R_2} = 32\mu\text{V}_{RMS} \times \frac{V_{OUT}}{V_{REF}} \quad (3)$$

Because the value of  $V_{REF}$  is 1.2 V, this relationship reduces to 式 4.

$$V_N(\mu\text{V}_{RMS}) = 27 \left( \frac{\mu\text{V}_{RMS}}{\text{V}} \right) \times V_{OUT}(\text{V}) \quad (4)$$

for the case of no  $C_{NR}$ .

An internal  $27\text{k}\Omega$  resistor in series with the noise reduction pin (NR) forms a low-pass filter for the voltage reference when an external noise reduction capacitor,  $C_{NR}$ , is connected from NR to ground. For  $C_{NR} = 10\text{nF}$ , the total noise in the 10Hz to 100kHz bandwidth is reduced by a factor of approximately 3.2, giving the approximate relationship in 式 5:

$$V_N(\mu\text{V}_{RMS}) = 8.5 \left( \frac{\mu\text{V}_{RMS}}{\text{V}} \right) \times V_{OUT}(\text{V}) \quad (5)$$

for  $C_{NR} = 10\text{nF}$ .

This noise reduction effect is shown in 図 5-33 in the *Typical Characteristics* table.

The TPS73601 adjustable version does not have the NR pin available. However, connecting a feedback capacitor,  $C_{FB}$ , from the output to the feedback pin (FB) reduces output noise and improves load transient performance.

The TPS736xx-Q1 uses an internal charge pump to develop an internal supply voltage sufficient to drive the gate of the NMOS pass element above  $V_{OUT}$ . The charge pump generates approximately  $250\mu\text{V}$  of switching noise at approximately 4 MHz; however, charge-pump noise contribution is negligible at the output of the regulator for most values of  $I_{OUT}$  and  $C_{OUT}$ .

7.2.1.3 Application Curves

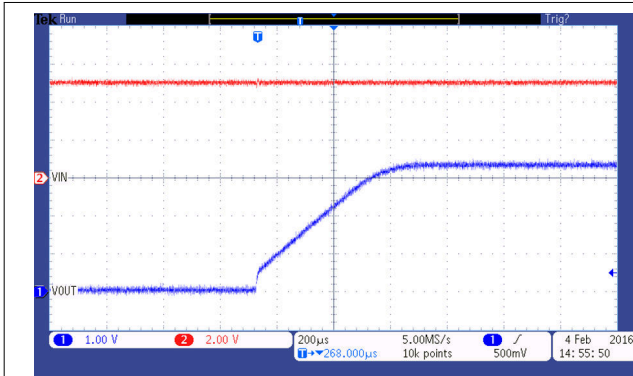

Legacy silicon

图 7-2. TPS73601 Start-Up

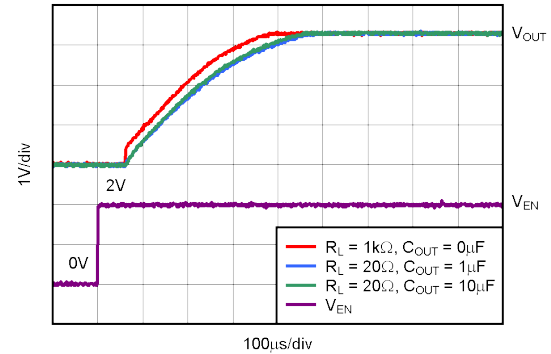

100µs/div

New silicon

图 7-3. TPS73601 Start-Up

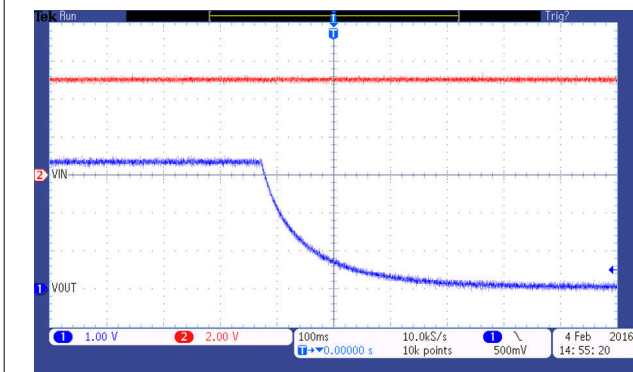

Legacy silicon

图 7-4. TPS73601 Shutdown

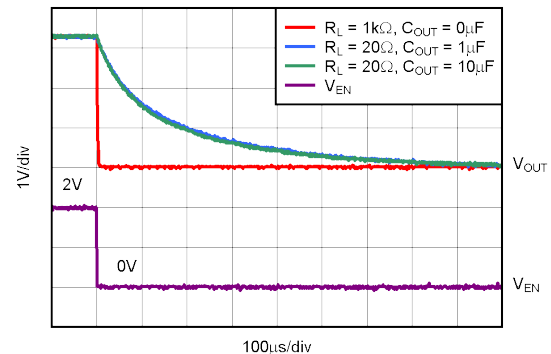

100µs/div

New silicon

图 7-5. TPS73601 Shutdown

7.2.2 Typical Application Circuit for Adjustable-Voltage Version

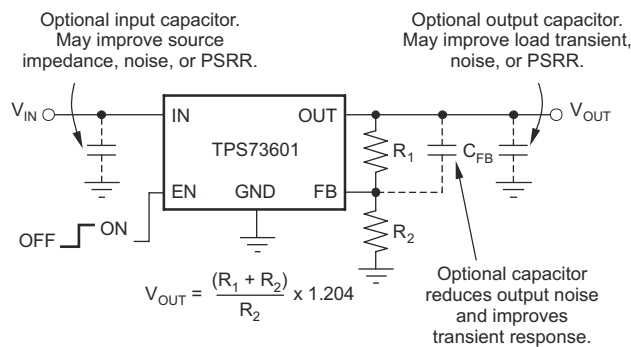

Copyright © 2016, Texas Instruments Incorporated

图 7-6. Typical Application Circuit for Adjustable-Voltage Version

7.2.2.1 Design Requirements

For this design example, use the parameters listed in 表 7-2 as the input parameters.

表 7-2. Design Parameters (Adjustable-Voltage Version)

PARAMETER	EXAMPLE VALUE
Input voltage	5V, $\pm 3\%$ , provided by the DC-DC converter switching at 1MHz
Output voltage	2.5V, $\pm 1\%$
Output current	0.4A (maximum), 10mA (minimum)
RMS noise, 10Hz to 100kHz	$< 35\mu\text{V}_{\text{RMS}}$
Ambient temperature	55°C (maximum)

### 7.3 Power Supply Recommendations

This device is designed to operate with an input supply range of 1.7 V to 5.5 V. If the input supply is noisy, additional input capacitors with low ESR can help improve output noise performance.

### 7.4 Layout

#### 7.4.1 Layout Example



図 7-7. Layout Example for the DBV Package Adjustable Version



図 7-8. Layout Example for the DBV Package Fixed Version

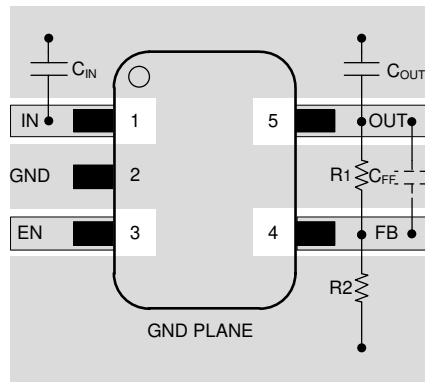

図 7-9. Layout Example for the DCQ Package Adjustable Version

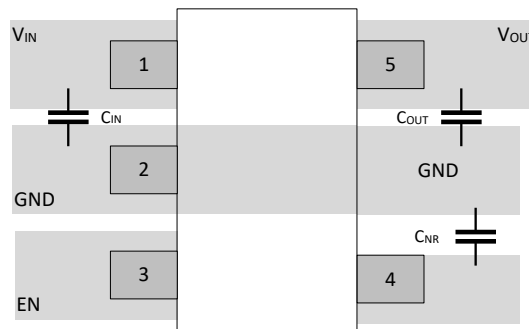

図 7-10. Layout Example for the DCQ Package Fixed Version

### 7.4.2 Thermal Considerations

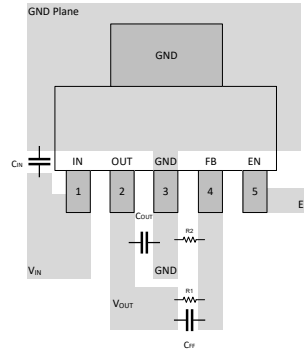
The ability to remove heat from the die is different for each package type, presenting different considerations in the PCB layout. The PCB area around the device that is free of other components moves the heat from the device to the ambient air. Performance data for JEDEC low- and high-K boards are shown in the [セクション 5.4](#) table. Using heavier copper increases the effectiveness in removing heat from the device. The addition of plated through-holes to heat-dissipating layers also improve the heat sink effectiveness.

Power dissipation depends on input voltage and load conditions. Power dissipation ( $P_D$ ) is equal to the product of the output current times the voltage drop across the output pass element ( $V_{IN}$  to  $V_{OUT}$ ), shown in [式 6](#):

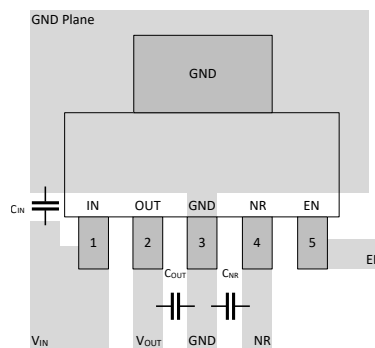
$$P_D = (V_{IN} - V_{OUT}) \times I_{OUT} \tag{6}$$

Power dissipation can be minimized by using the lowest possible input voltage necessary to assure the required output voltage.

### 7.4.3 Layout Guidelines

To improve AC performance such as PSRR, output noise, and transient response, design the board with ground plane connections for  $V_{IN}$  and  $V_{OUT}$  capacitors, and the ground plane connected at the GND pin of the device. In addition, the ground connection for the bypass capacitor must connect directly to the GND pin of the device.

## 8 Device And Documentation Support

### 8.1 Device Support

#### 8.1.1 Device Nomenclature

表 8-1. Ordering Information <sup>(1)</sup>

PRODUCT	DESCRIPTION <sup>(1)</sup>
TPS736xxQyyy(M3)Q1	<p><b>xx</b> is the nominal output voltage (for example, 25 = 2.5 V, 01 = Adjustable <sup>(2)</sup>).</p> <p><b>Q</b> indicates that the device is a grade-1 device in accordance with the AEC-Q100 standard.</p> <p><b>yyy</b> is the package designator.</p> <p><b>z</b> is the package quantity.</p> <p><b>M3</b> is a suffix designator for devices that only use the latest manufacturing flow (CSO: RFB). Devices without this suffix can ship with the <i>legacy silicon</i> (CSO: DLN) or the <i>new silicon</i> (CSO: RFB). The reel packaging label provides CSO information to distinguish which silicon is being used. Device performance for new and legacy silicon is denoted throughout the document.</p> <p><b>Q1</b> indicates that this device is an automotive grade (AEC-Q100) device.</p>

- (1) For the most current package and ordering information see the Package Option Addendum at the end of this document, or see the device product folder at [www.ti.com](http://www.ti.com).
- (2) For fixed 1.20-V operation, tie FB to OUT.

### 8.2 ドキュメントの更新通知を受け取る方法

ドキュメントの更新についての通知を受け取るには、[www.tij.co.jp](http://www.tij.co.jp) のデバイス製品フォルダを開いてください。[通知] をクリックして登録すると、変更されたすべての製品情報に関するダイジェストを毎週受け取ることができます。変更の詳細については、改訂されたドキュメントに含まれている改訂履歴をご覧ください。

### 8.3 サポート・リソース

テキサス・インスツルメンツ E2E™ サポート・フォーラムは、エンジニアが検証済みの回答と設計に関するヒントをエキスパートから迅速かつ直接得ることができる場所です。既存の回答を検索したり、独自の質問をしたりすることで、設計に必要な支援を迅速に得ることができます。

リンクされているコンテンツは、各寄稿者により「現状のまま」提供されるものです。これらはテキサス・インスツルメンツの仕様を構成するものではなく、必ずしもテキサス・インスツルメンツの見解を反映したものではありません。テキサス・インスツルメンツの [使用条件](#) を参照してください。

### 8.4 Trademarks

テキサス・インスツルメンツ E2E™ is a trademark of Texas Instruments.  
すべての商標は、それぞれの所有者に帰属します。

### 8.5 静電気放電に関する注意事項



この IC は、ESD によって破損する可能性があります。テキサス・インスツルメンツは、IC を取り扱う際には常に適切な注意を払うことを推奨します。正しい取り扱いおよび設置手順に従わない場合、デバイスを破損するおそれがあります。

ESD による破損は、わずかな性能低下からデバイスの完全な故障まで多岐にわたります。精密な IC の場合、パラメータがわずかに変化するだけで公表されている仕様から外れる可能性があるため、破損が発生しやすくなっています。

### 8.6 用語集

[テキサス・インスツルメンツ用語集](#) この用語集には、用語や略語の一覧および定義が記載されています。

## 9 Revision History

資料番号末尾の英字は改訂を表しています。その改訂履歴は英語版に準じています。

Changes from Revision A (May 2016) to Revision B (December 2024)	Page
ドキュメント全体にわたって表、図、相互参照の採番方法を更新.....	1
現在のファミリのフォーマットに合わせてドキュメント全体を変更.....	1

• ドキュメントに M3 デバイスを追加.....	1
• Changed $V_{FB}$ typical value.....	5
• Deleted <i>Layout Guidelines</i> .....	21
• Deleted <i>Documentation Support and Related Documentation</i> .....	23

---

<b>Changes from Revision * (September 2010) to Revision A (May 2016)</b>	<b>Page</b>
--	-------------

• Added 「アプリケーション」セクション、「製品情報」表、目次、「改訂履歴」セクション、「仕様」セクション、「ESD 定格」表、「推奨動作条件」表、「詳細説明」セクション、「アプリケーションと実装」セクション、「電源に関する推奨事項」セクション、「レイアウト」セクション、「デバイスおよびドキュメントのサポート」セクション、「メカニカル、パッケージ、および注文情報」セクションを追加 .....	1
• 「注文情報」表を削除 .....	1

---

## 10 Mechanical, Packaging, And Orderable Information

The following pages include mechanical, packaging, and orderable information. This information is the most current data available for the designated devices. This data is subject to change without notice and revision of this document. For browser-based versions of this data sheet, refer to the left-hand navigation.



**PACKAGING INFORMATION**

Orderable Device	Status (1)	Package Type	Package Drawing	Pins	Package Qty	Eco Plan (2)	Lead finish/ Ball material (6)	MSL Peak Temp (3)	Op Temp (°C)	Device Marking (4/5)	Samples
TPS73601QDBVRQ1	ACTIVE	SOT-23	DBV	5	3000	RoHS & Green	NIPDAU	Level-1-260C-UNLIM	-40 to 125	PTWQ	Samples
TPS73618QDCQRQ1	ACTIVE	SOT-223	DCQ	6	2500	RoHS & Green	NIPDAU	Level-3-260C-168 HR	-40 to 125	73618Q	Samples

(1) The marketing status values are defined as follows:

**ACTIVE:** Product device recommended for new designs.

**LIFEBUY:** TI has announced that the device will be discontinued, and a lifetime-buy period is in effect.

**NRND:** Not recommended for new designs. Device is in production to support existing customers, but TI does not recommend using this part in a new design.

**PREVIEW:** Device has been announced but is not in production. Samples may or may not be available.

**OBSOLETE:** TI has discontinued the production of the device.

(2) **RoHS:** TI defines "RoHS" to mean semiconductor products that are compliant with the current EU RoHS requirements for all 10 RoHS substances, including the requirement that RoHS substance do not exceed 0.1% by weight in homogeneous materials. Where designed to be soldered at high temperatures, "RoHS" products are suitable for use in specified lead-free processes. TI may reference these types of products as "Pb-Free".

**RoHS Exempt:** TI defines "RoHS Exempt" to mean products that contain lead but are compliant with EU RoHS pursuant to a specific EU RoHS exemption.

**Green:** TI defines "Green" to mean the content of Chlorine (Cl) and Bromine (Br) based flame retardants meet JS709B low halogen requirements of <=1000ppm threshold. Antimony trioxide based flame retardants must also meet the <=1000ppm threshold requirement.

(3) MSL, Peak Temp. - The Moisture Sensitivity Level rating according to the JEDEC industry standard classifications, and peak solder temperature.

(4) There may be additional marking, which relates to the logo, the lot trace code information, or the environmental category on the device.

(5) Multiple Device Markings will be inside parentheses. Only one Device Marking contained in parentheses and separated by a "~" will appear on a device. If a line is indented then it is a continuation of the previous line and the two combined represent the entire Device Marking for that device.

(6) Lead finish/Ball material - Orderable Devices may have multiple material finish options. Finish options are separated by a vertical ruled line. Lead finish/Ball material values may wrap to two lines if the finish value exceeds the maximum column width.

**Important Information and Disclaimer:**The information provided on this page represents TI's knowledge and belief as of the date that it is provided. TI bases its knowledge and belief on information provided by third parties, and makes no representation or warranty as to the accuracy of such information. Efforts are underway to better integrate information from third parties. TI has taken and continues to take reasonable steps to provide representative and accurate information but may not have conducted destructive testing or chemical analysis on incoming materials and chemicals. TI and TI suppliers consider certain information to be proprietary, and thus CAS numbers and other limited information may not be available for release.

In no event shall TI's liability arising out of such information exceed the total purchase price of the TI part(s) at issue in this document sold by TI to Customer on an annual basis.

**OTHER QUALIFIED VERSIONS OF TPS736-Q1 :**

- Catalog : [TPS736](#)

## NOTE: Qualified Version Definitions:

- Catalog - TI's standard catalog product

**TAPE AND REEL INFORMATION**

**QUADRANT ASSIGNMENTS FOR PIN 1 ORIENTATION IN TAPE**

\*All dimensions are nominal

Device	Package Type	Package Drawing	Pins	SPQ	Reel Diameter (mm)	Reel Width W1 (mm)	A0 (mm)	B0 (mm)	K0 (mm)	P1 (mm)	W (mm)	Pin1 Quadrant
TPS73601QDBVRQ1	SOT-23	DBV	5	3000	179.0	8.4	3.2	3.2	1.4	4.0	8.0	Q3
TPS73618QDCQRQ1	SOT-223	DCQ	6	2500	330.0	12.4	7.1	7.45	1.88	8.0	12.0	Q3

**TAPE AND REEL BOX DIMENSIONS**

\*All dimensions are nominal

Device	Package Type	Package Drawing	Pins	SPQ	Length (mm)	Width (mm)	Height (mm)
TPS73601QDBVRQ1	SOT-23	DBV	5	3000	200.0	183.0	25.0
TPS73618QDCQRQ1	SOT-223	DCQ	6	2500	346.0	346.0	29.0

# DBV0005A



## PACKAGE OUTLINE

SOT-23 - 1.45 mm max height

SMALL OUTLINE TRANSISTOR



4214839/K 08/2024

### NOTES:

1. All linear dimensions are in millimeters. Any dimensions in parenthesis are for reference only. Dimensioning and tolerancing per ASME Y14.5M.
2. This drawing is subject to change without notice.
3. Reference JEDEC MO-178.
4. Body dimensions do not include mold flash, protrusions, or gate burrs. Mold flash, protrusions, or gate burrs shall not exceed 0.25 mm per side.
5. Support pin may differ or may not be present.

# EXAMPLE BOARD LAYOUT

DBV0005A

SOT-23 - 1.45 mm max height

SMALL OUTLINE TRANSISTOR



LAND PATTERN EXAMPLE  
EXPOSED METAL SHOWN  
SCALE:15X



SOLDER MASK DETAILS

4214839/K 08/2024

NOTES: (continued)

- 6. Publication IPC-7351 may have alternate designs.
- 7. Solder mask tolerances between and around signal pads can vary based on board fabrication site.

# EXAMPLE STENCIL DESIGN

DBV0005A

SOT-23 - 1.45 mm max height

SMALL OUTLINE TRANSISTOR



SOLDER PASTE EXAMPLE  
BASED ON 0.125 mm THICK STENCIL  
SCALE:15X

4214839/K 08/2024

NOTES: (continued)

8. Laser cutting apertures with trapezoidal walls and rounded corners may offer better paste release. IPC-7525 may have alternate design recommendations.
9. Board assembly site may have different recommendations for stencil design.

# DCQ0006A

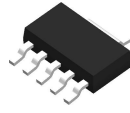

# PACKAGE OUTLINE

## SOT - 1.8 mm max height

PLASTIC SMALL OUTLINE

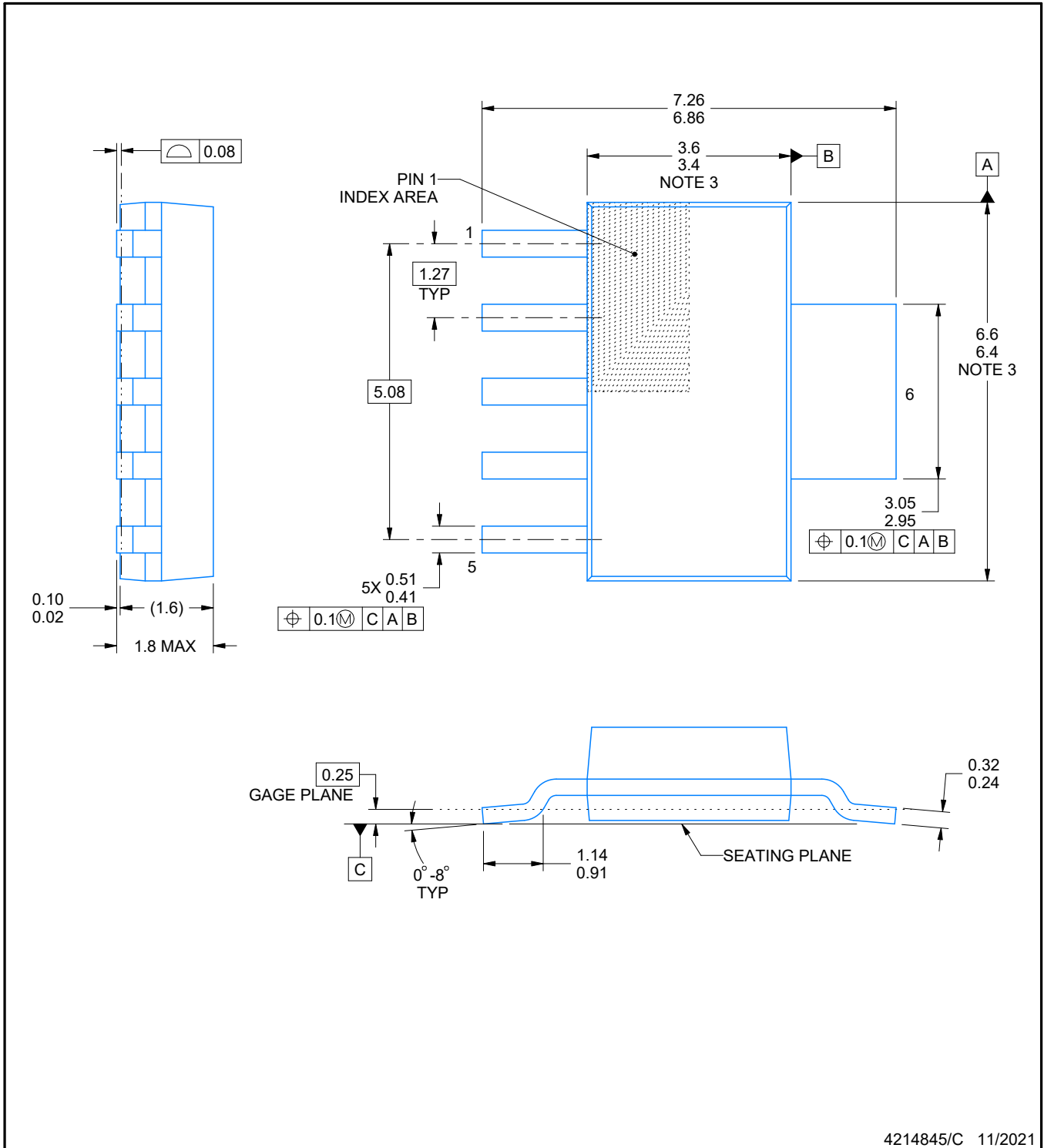

4214845/C 11/2021

### NOTES:

1. All linear dimensions are in millimeters. Any dimensions in parenthesis are for reference only. Dimensioning and tolerancing per ASME Y14.5M.
2. This drawing is subject to change without notice.
3. This dimension does not include mold flash, protrusions, or gate burrs. Mold flash, protrusions, or gate burrs shall not exceed 0.15 mm per side.



# EXAMPLE BOARD LAYOUT

DCQ0006A

SOT - 1.8 mm max height

PLASTIC SMALL OUTLINE



LAND PATTERN EXAMPLE  
EXPOSED METAL SHOWN  
SCALE: 10X

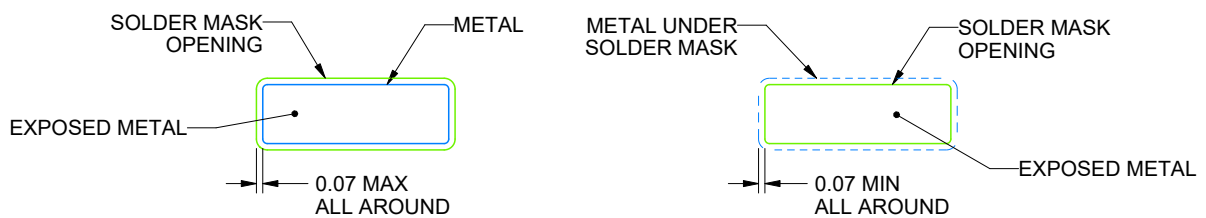

SOLDER MASK DETAILS

4214845/C 11/2021

NOTES: (continued)

4. Publication IPC-7351 may have alternate designs.
5. Solder mask tolerances between and around signal pads can vary based on board fabrication site.
6. Vias are optional depending on application, refer to device data sheet. If any vias are implemented, refer to their locations shown on this view. It is recommended that vias under paste be filled, plugged or tented.

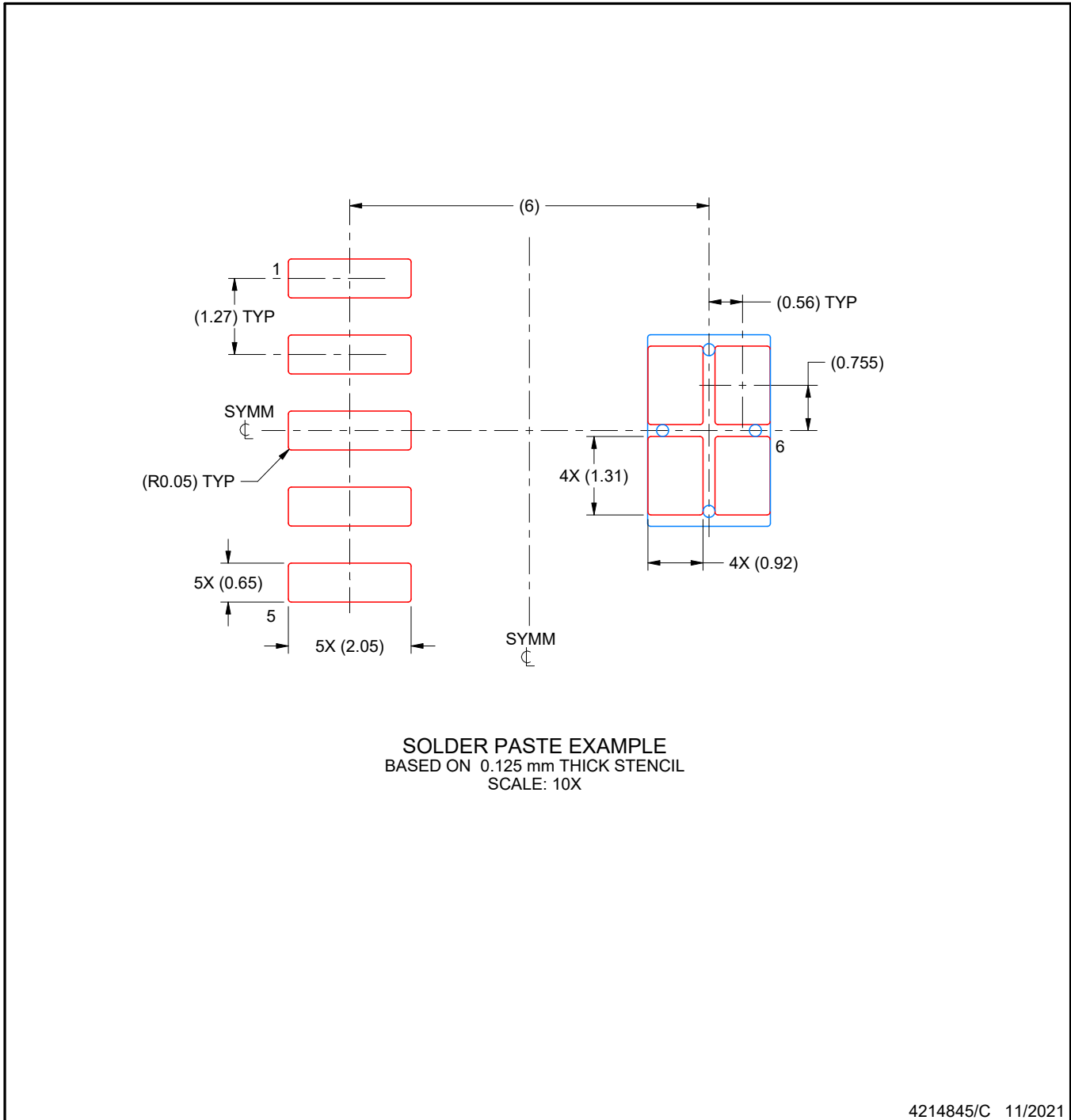

NOTES: (continued)

- 7. Laser cutting apertures with trapezoidal walls and rounded corners may offer better paste release. IPC-7525 may have alternate design recommendations.
- 8. Board assembly site may have different recommendations for stencil design.

## 重要なお知らせと免責事項

テキサス・インスツルメンツは、技術データと信頼性データ(データシートを含みます)、設計リソース(リファレンス デザインを含みます)、アプリケーションや設計に関する各種アドバイス、Web ツール、安全性情報、その他のリソースを、欠陥が存在する可能性のある「現状のまま」提供しており、商品性および特定目的に対する適合性の黙示保証、第三者の知的財産権の非侵害保証を含むいかなる保証も、明示的または黙示的にかかわらず拒否します。

これらのリソースは、テキサス・インスツルメンツ製品を使用する設計の経験を積んだ開発者への提供を意図したものです。(1) お客様のアプリケーションに適したテキサス・インスツルメンツ製品の選定、(2) お客様のアプリケーションの設計、検証、試験、(3) お客様のアプリケーションに該当する各種規格や、その他のあらゆる安全性、セキュリティ、規制、または他の要件への確実な適合に関する責任を、お客様のみが単独で負うものとし、ます。

上記の各種リソースは、予告なく変更される可能性があります。これらのリソースは、リソースで説明されているテキサス・インスツルメンツ製品を使用するアプリケーションの開発の目的でのみ、テキサス・インスツルメンツはその使用をお客様に許諾します。これらのリソースに関して、他の目的で複製することや掲載することは禁止されています。テキサス・インスツルメンツや第三者の知的財産権のライセンスが付与されている訳ではありません。お客様は、これらのリソースを自身で使用した結果発生するあらゆる申し立て、損害、費用、損失、責任について、テキサス・インスツルメンツおよびその代理人を完全に補償するものとし、テキサス・インスツルメンツは一切の責任を拒否します。

テキサス・インスツルメンツの製品は、[テキサス・インスツルメンツの販売条件](#)、または [ti.com](https://www.ti.com) やかかるテキサス・インスツルメンツ製品の関連資料などのいずれかを通じて提供する適用可能な条項の下で提供されています。テキサス・インスツルメンツがこれらのリソースを提供することは、適用されるテキサス・インスツルメンツの保証または他の保証の放棄の拡大や変更を意味するものではありません。

お客様がいかなる追加条項または代替条項を提案した場合でも、テキサス・インスツルメンツはそれらに異議を唱え、拒否します。

郵送先住所：Texas Instruments, Post Office Box 655303, Dallas, Texas 75265  
Copyright © 2025, Texas Instruments Incorporated