

安全関連アプリケーションのマイコン用TPS65381A-Q1マルチレール電源

1 デバイスの概要

1.1 特長

- 車載アプリケーションに認定済み
- 下記内容でAEC-Q100認定済み
 - デバイス温度グレード 1: 動作時周囲温度 -40°C~+125°C
 - デバイスHBM ESD分類レベルH2
 - デバイスCDM ESD分類レベルC3B
- マルチレール電源でのサポート
 - TI Hercules™TMS570, C2000™および各種の機能的安全性アーキテクチャ・マイコン
- 電源レール
 - 入力電圧範囲:
 - 5.8V~36V (CAN, I/O, MCUコア、センサ電源レギュレータ用)
 - 4.5V~5.8V (3.3V I/OおよびMCUコア・レギュレータ用)
 - 内部FET付き6V非同期スイッチ・モード・プリレギュレータ、1.3A出力電流
 - 5V (CAN)電源電圧、FET内蔵リニア・レギュレータ、300mA出力電流
 - 3.3または5Vの(MCU I/O)電圧、FET内蔵リニア・レギュレータ、300mA出力電流
 - 0.8V~3.3V可変(MCUコア電圧)、リニア・レギュレータ・コントローラ、外部FET
 - 3.3V~9.5V可変センサ電源: 内部FET付きリニア・トラッキング・レギュレータ、100mA出力電流、電源およびグラウンドへの短絡に対する保護
 - 通常バッテリー電圧を12V上回るチャージ・ポンプ
- 電源およびシステム監視
 - すべてのレギュレータ出力、バッテリー電圧、および内部電源に対する独立した低電圧/過電圧監視
 - レギュレータ・リファレンスおよび電圧監視回路に対して独立した電圧リファレンスを提供。独立バンドギャップ・リファレンスおよび個別電源入力ピンを備えた電圧監視回路
 - すべての電圧監視機能に対するセルフチェック機能 (パワーアップ中に自動動作、加えてパワーアップ後に外部MCUIにより起動可能)
 - すべての内部FET付き電源を電流制限および過熱シャットダウンで保護
- マイクロコントローラ(MCU)インターフェイス
 - ウォッチドッグ: トリガ・モード (OPEN/CLOSE ウィンドウ式) または質疑応答モード
 - ロックステップ・デュアルコアMCU用のMCUエラー信号モニタ: Hercules™ TMS570, C2000™、およびパルス幅変調(PWM)エラー出力を使用する各種の機能的安全性アーキテクチャMCU
 - DIAGNOSTIC状態: デバイスのセルフ・テスト、診断、外部インターコネクト・チェック用
 - SAFE状態: 故障検出時のデバイスおよびシステム保護用
 - デバイス内部発振器用のクロック・モニタ
 - デバイス起動時とDIAGNOSTIC状態のMCUによってアクティブ化されるたびに、アナログ回路およびロジック回路のセルフ・テストを実行
 - 不揮発性メモリに対するCRC (デバイスレジスタおよび構成レジスタ)
 - MCU用のリセット回路と出カピン
 - マルチプレクサを介したデバイス内部のアナログおよびデジタル信号の監視を可能にする診断出力ピン
- シリアル・ペリフェラル・インターフェイス (SPI)
 - 構成レジスタ
 - ウォッチドッグの質疑応答
 - 診断ステータスの読み出し
 - 3.3Vおよび5Vの論理レベルに対応
- イネーブル・ドライブ出力: システム故障検出時の安全化パスまたは外部パワー段のディスエーブル用
- IGNITIONピンまたはCAN WAKUPピン経由のウェークアップ
- パッケージ: 32ピンHTSSOP PowerPAD™ ICパッケージ



1.2 アプリケーション

- 安全関連オートモーティブ・アプリケーション
 - パワー・ステアリング: 電動パワー・ステアリング (EPS) および 電動油圧パワー・ステアリング (EHPS)
 - ブレーキング: アンチロック・ブレーキ・システム (ABS)、横滑り防止装置 (ESC)、電動パーキング・ブレーキ
 - 先進運転支援システム (ADAS)
 - サスペンション
- 産業用の安全関連アプリケーション
 - 安全関連プログラマブル・ロジック・コントローラ (PLC)
 - 安全関連 I/O コントロール・モジュール
 - 試験および測定機器
 - 鉄道および地下鉄の信号制御と安全関連モジュール
 - エレベータおよびエスカレータの安全制御
 - 風力タービン制御

1.3 概要

TPS65381A-Q1 デバイスは、自動車市場および産業用市場で見られるような安全関連アプリケーションのマイコン (MCU) に電源を供給するために設計されたマルチレール電源装置です。このデバイスは、テキサス・インスツルメンツの Hercules™ TMS570 MCU および C2000™ MCU ファミリーと、デュアル・コア・ロックステップ (LS) または疎結合 (LC) アーキテクチャを使用する各種マイコンをサポートします。

TPS65381A-Q1 デバイスは、MCU、コントローラ・エリア・ネットワーク (CAN)、FlexRay または外部センサに電源を供給する複数の電源レールを内蔵しています。内部 FET 付きの非同期降圧スイッチ・モード電源コンバータが、入力電源 (バッテリー) 電圧を 6V のプリレギュレータ出力に変換して、他のレギュレータに供給します。このデバイスは、イグニッション信号からのウェークアップ、または CAN トランシーバ信号からのウェークアップをサポートします。

内部 FET 付きの内蔵固定 5V リニア・レギュレータは、例えば CAN または FlexRay トランシーバに電源を供給するために使用できます。2 番目のリニア・レギュレータ (内部 FET 付き) は、選択可能な 5V または 3.3V の出力をレギュレートします。この出力を、例えば MCU の I/O 電圧に使用できます。

TPS65381A-Q1 デバイスは、調整可能なリニア・レギュレータ・コントローラを内蔵しており、外部 FET と抵抗分圧回路を使用して、0.8V ~ 3.3V の調整可能電圧にレギュレートします。この電圧は MCU コア電源で使用できます。

内蔵センサ電源はトラッキング・モードまたは調整可能出力モードで動作し、グラウンドおよびバッテリーへの短絡に対する保護を備えています。そのため、このレギュレータは、モジュールまたは電子制御ユニット (ECU) の外部にあるセンサに電源を供給できます。

内蔵チャージ・ポンプは、内部レギュレータにオーバードライブ電圧を供給します。また、チャージ・ポンプ出力を使用して外部 NMOS トランジスタを制御することで、逆バッテリー保護回路で使用できます。このソリューションでは、できるだけ低い電源電圧でのデバイス動作が必要な場合に、従来の逆バッテリー防止ダイオードよりも低い最小バッテリー電圧で動作させることができます。

このデバイスは、すべてのレギュレータ出力、バッテリー電圧、内部電源レールで低電圧と過電圧を監視します。メインのバンドギャップ・リファレンスで検出を免れるドリフトがないようにするため、メインのバンドギャップ・リファレンスから独立した 2 番目のバンドギャップ・リファレンスを使用して低電圧と過電圧を監視します。さらに、レギュレータの電流制限と過熱保護が実装されています。

TPS65381A-Q1 デバイ스에搭載された監視および保護機能には、トリガ付きウォッチドッグおよび質疑応答モード、MCU エラー信号モニタ、内部発振器のクロック・モニタ、クロック・モニタのセルフチェック、不揮発性メモリに対する巡回冗長検査 (CRC)、MCU によるデバイス内部アナログおよびデジタル信号の監視を可能にする診断出力ピン、MCU 用リセット回路および出力ピン、故障検出時に安全化パスまたは外部パワー段を無効にするイネーブル・ドライブ出力が含まれます。内蔵セルフ・テスト (BIST) は、起動時に自動的にデバイス機能を監視します。専用の DIAGNOSTIC 状態では、MCU が TPS65381A-Q1 の監視機能と保護機能を確認することができます。

TPS65381A-Q1 デバイスは、32ピン HTSSOP PowerPAD パッケージで供給されます。

製品情報⁽¹⁾

型番	パッケージ	本体サイズ (公称)
TPS65381A-Q1	HTSSOP (32)	11.00mm x 6.20mm

(1) 提供されているすべてのパッケージについては、巻末の注文情報を参照してください。

1.4 代表的なアプリケーションの図

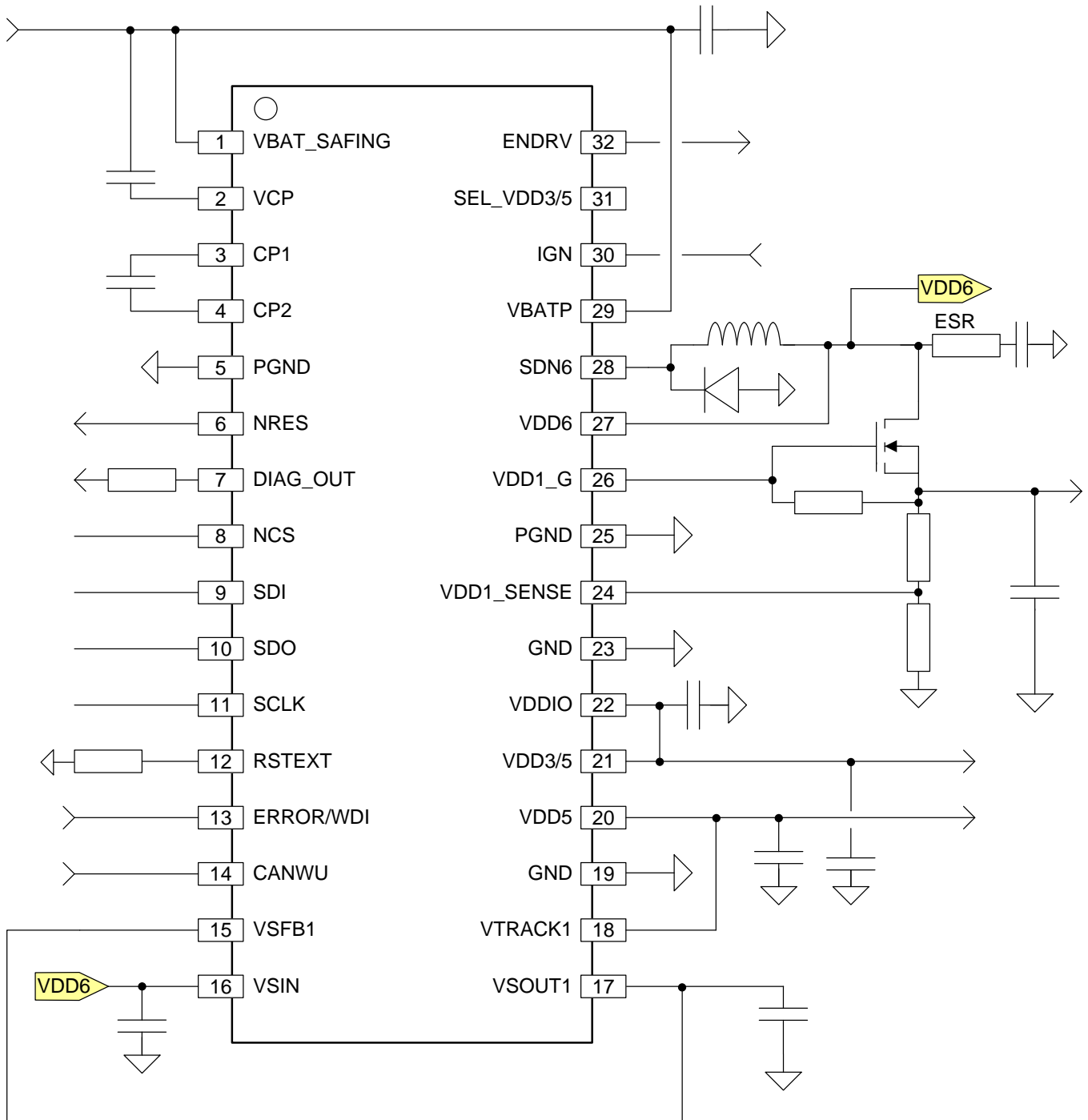

Copyright © 2016, Texas Instruments Incorporated

図 1-1. 代表的なアプリケーションの図

2 改訂履歴

資料番号末尾の英字は改訂を表しています。その改訂履歴は英語版に準じています。

2016年7月発行のものから更新

Page

-
- データシートのフル・バージョンをリリース [2](#)
-

3 Pin Configuration and Functions

The pin configuration drawing in this section is not to scale. For package dimensions, see the mechanical data in 10.

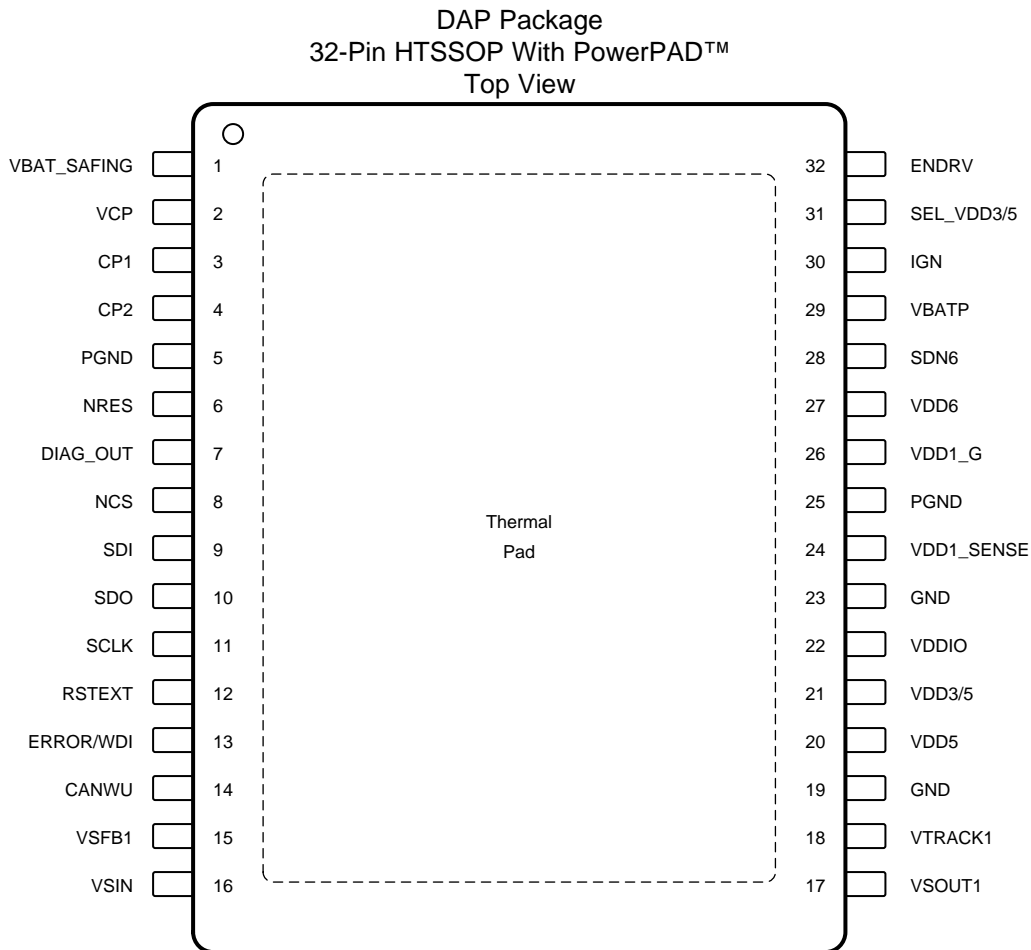

Pin Functions

PIN		TYPE	DESCRIPTION
NO.	NAME		
1	VBAT_SAFING	PWR	Battery (supply) input for monitoring (VMON) and BG2 functions (must be reverse protected), should be connected to VBATP
2	VCP	PWR	Charge-pump output voltage
3	CP1	PWR	Charge-pump external capacitor, high-voltage side
4	CP2	PWR	Charge-pump external capacitor, low-voltage side
5	PGND	GND	Ground (power)
6	NRES	O	Cold reset output signal for the microcontroller (MCU) (active-low, internal pullup, open drain output)
7	DIAG_OUT	O	Diagnostic output pin for diagnostic MUX. Internal analog (AMUX) and digital (DMUX) signal connection to MCU ADC and digital IO
8	NCS	I	SPI chip select (active-low, internal pullup)
9	SDI	I	SPI serial data IN (internal pulldown)
10	SDO	O	SPI serial data OUT
11	SCLK	I	SPI clock (internal pull down)
12	RSTEXT	I	Configuration pin to set reset extension time through a resistor to GND

Pin Functions (continued)

PIN		TYPE	DESCRIPTION
NO.	NAME		
13	ERROR/WDI	I	Error input signal from the MCU while using the MCU ESM (with the watchdog in Q&A Mode), trigger input for the watchdog in trigger mode (MCU ESM not used). This pin is edge triggered.
14	CANWU	I	Wake-up input from CAN transceiver, other transceiver or other source. Wake-up request latched with CANWU_L. (internal pulldown)
15	VSFB1	I	Feedback input reference for sensor supply regulator (VSOUT1)
16	VSIN	PWR	Input supply voltage for the sensor-supply regulator (VSOUT1)
17	VSOUT1	PWR	Output voltage for the VSOUT1 sensor-supply regulator
18	VTRACK1	I	Tracking input reference for sensor-supply regulator (VSOUT1) (internal pulldown)
19	GND	GND	Ground (analog)
23	GND	GND	Ground (analog)
20	VDD5	PWR	VDD5 regulator output voltage
21	VDD3/5	PWR	VDD3/5 regulator output voltage
22	VDDIO	PWR	I/O supply input for pins to and from the MCU
24	VDD1_SENSE	I	Reference input for VDD1 regulator (feedback) and input for UV/OV monitoring of VDD1 regulator
25	PGND	GND	Ground (power)
26	VDD1_G	O	Gate drive of external FET for VDD1 regulator
27	VDD6	PWR	VDD6 switch mode regulator feedback input and supply input for integrated VDD5 and VDD3/5 regulators
28	SDN6	PWR	Switching node for VDD6 switch mode regulator
29	VBATP	PWR	Battery (supply) voltage (must be reverse protected), main power supply input for device
30	IGN	I	Wake-up input from ignition (key) or other source (internal pulldown)
31	SEL_VDD3/5	I	Input selects voltage level for VDD3/5 regulator (SEL_VDD3/5 pin open: 3.3-V regulation from VDD3/5; SEL_VDD3/5 pin to GND: 5-V regulation from VDD3/5)
32	ENDRV	O	Enable output signal for peripherals (for example, motor-driver IC), safing path output (internal pullup, open drain output)
—	Thermal pad	—	Place thermal vias to large ground plane and connect to GND and PGND pins.

4 Specifications

4.1 Absolute Maximum Ratings

Over operating free-air temperature range (unless otherwise noted)⁽¹⁾⁽²⁾

POS			MIN	MAX	UNIT
M1.1	Protected-battery voltage	VBATP, VBAT_SAFING, VSIN	-0.3	40	V
M1.2	Charge-pump voltage	VCP, CP1 ⁽³⁾	-0.3	lesser of VBATP + 16 or 52	V
M1.3	Charge-pump pumping capacitor voltage	CP2	-0.3	40	V
M1.3a	Charge-pump overdrive voltage	VCP ⁽³⁾ -VBATP	-0.3	16	V
M1.4	VDD6 switching-node voltage	SDN6	-0.3	40	V
M1.5	VDD6 output voltage	VDD6	-0.3	40	V
M1.6	VDD5 output voltage	VDD5	-0.3	7	V
M1.7	VDD3/5 output voltage	VDD3/5	-0.3	7	V
M1.8	VDD1_G voltage	VDD1_G	-0.3	15	V
M1.10	VDD1_SENSE voltage	VDD1_SENSE	-0.3	7	V
M1.11	Sensor supply tracking voltage	VTRACK1	-0.3	40	V
M1.12	Sensor supply output and feedback voltage	VSOUT1, VSFB1 ⁽⁴⁾	-2	18	V
M1.14	Analog/digital reference output voltage	DIAG_OUT	-0.3	7	V
M1.15	Logic I/O voltage	VDDIO, ERROR/WDI, ENDRV, NRES, NCS, SDI, SDO, SCLK, RSTEXT	-0.3	7	V
M1.16		SEL_VDD3/5	-0.3	40	V
M1.17	IGN wakeup	IGN	-7	40	V
M1.18	CAN wakeup	CANWU	-0.3	40	V
M1.19	Operating virtual junction temperature, T _J			150	°C
	Storage temperature, T _{stg}		-65	150	°C

- (1) Stresses beyond those listed under *Absolute Maximum Ratings* may cause permanent damage to the device. These are stress ratings only, which do not imply functional operation of the device at these or any other conditions beyond those indicated under *Recommended Operating Conditions*. Exposure to absolute-maximum-rated conditions for extended periods may affect device reliability.
- (2) All voltage values are with respect to the network ground pin unless otherwise noted.
- (3) VCP and CP1 are output pins, no external voltage should be applied to these pins. Absolute Maximum ratings for these pins are what may appear on the pins.
- (4) VSOUT1 is connected to VSFB1 directly (for unity gain) or through resistor divider (tracking mode gain or non-tracking mode output voltage adjusting). In case of a short to supply fault, the voltage on VSOUT1 is equal to the supply to the device (VBATP, VBAT_SAFING, and VSIN where VSIN is connected to VBATP as its supply instead of VDD6) and VSFB1 voltage will follow VSOUT1 based on the use case, directly (for unity gain) or via resistor divider (tracking mode gain or non-tracking mode output voltage adjusting).

4.2 ESD Ratings

POS.			VALUE	UNIT		
M1.21	V _(ESD)	Electrostatic discharge	Human body model (HBM), per AEC Q100-002 ⁽¹⁾	All pins except VSOUT1 (17) and VSFB1 (15)	±2000	V
M1.20				On sensor supply pins VSOUT1 (17) and VSFB1 (15)	±4000	
M1.22		Charged device model (CDM), per AEC Q100-011	Corner pins (1, 16, 17, and 32)	±750		
M1.23			All pins	±500		

- (1) AEC Q100-002 indicates that HBM stressing is done in accordance with the ANSI/ESDA/JEDEC JS-001 Specification.

4.3 Recommended Operating Conditions

Over operating temperature range and with respect to the GND and PGND (GND = PGND) pins (unless otherwise noted)

POS		MIN	MAX	UNIT
M1.20a	Operating ambient temperature, T_A	-40	125	°C
R1.1	Minimum input supply voltage on VBATP for initial power up (POS 6.2, $VBATP_UV_{on}$) ⁽¹⁾⁽²⁾		5.8 ⁽³⁾	V
R1.2	Input supply voltage on VBATP ⁽¹⁾⁽²⁾⁽⁴⁾ <ul style="list-style-type: none"> To support operation when VBATP is between 5.8 V and 7 V, the device remains functional. Some rails can be in dropout or undervoltage depending on actual input supply and the configuration of the specific regulator. VDD6 can be in dropout mode (100% duty cycle) VDD3/5 configured for 5-V output can be in dropout. If the output reaches VDD3/5_UV threshold, the device transitions to the RESET state because of a VDD3/5 undervoltage event. If VDD3/5 is configured for 3.3-V output it remains functional. VDD5 can be in dropout. If output reaches the VDD5_UV threshold, the device indicates the undervoltage event through the VDD5_UV status bit. VSOUT1 can be in dropout depending on configuration. If output reaches VSOUT1_UV threshold, the device indicates the undervoltage event through the VSOUT1_UV status bit. 	5.8	34 ⁽⁵⁾	V
R1.3	Input supply voltage on VBATP after initial power up, functional operation during low input supply voltage events, (POS 6.1, $VBATP_UV_{off}$) ⁽¹⁾⁽⁶⁾ <ul style="list-style-type: none"> The device remains functional. Some rails can be in dropout or undervoltage depending on actual input supply and the configuration of the specific regulator. VDD6 is in dropout mode (100% duty cycle). VDD3/5 configured for 5-V output can be in dropout. If the output reaches VDD3/5_UV threshold, the device transitions to the RESET state because of a VDD3/5 undervoltage event. If VDD3/5 is configured for 3.3-V output it remains functional. VDD5 can be in dropout. If the output reaches VDD5_UV threshold, the device indicates the undervoltage event through the VDD5_UV status bit. VSOUT1 may be in dropout depending on configuration, if output reaches VSOUT1_UV threshold the device indicates the undervoltage event through the VSOUT1_UV status bit. 	4.5	5.8	V
R1.4	VDDIO supply-voltage range	3.3	5	V
R1.5	Current consumption in standby mode (all regulator outputs disabled) IGN = 0 V, CANWU = 0 V, $5.8\text{ V} \leq VBAT \leq 20\text{ V}$ for $T_J < 85^\circ\text{C}$ or $5.8\text{ V} \leq VBAT \leq 14\text{ V}$ for $T_J = 125^\circ\text{C}$		75	μA

- (1) VBATP should be connected to VBAT_SAFING.
- (2) VBAT_SAFING has a supply high enough to power the VMON block and internal rail AVDD_VMON above AVDD_VMON_UV.
- (3) The device may power up when VBATP is less than 5.8 V, but it will always power up when VBATP is 5.8V or greater, while VBAT_SAFING has a supply high enough to power the VMON block and internal rail AVDD_VMON above AVDD_VMON_UV.
- (4) Under slow VBAT ramp-down and when VDD3/5 rail is configured as a 5-V rail, the NRES output can be pulled low when VBAT is at approximately 6.3 V. This occurs because of an undervoltage transient on the VDD3/5 rail.
Under slow VBAT ramp-up and when VDD3/5 rail is configured as a 5-V rail, the NRES output can be pulled low when VBAT is at approximately 6.6 V. This occurs because of an undervoltage transient on VDD3/5 rail. Under similar conditions, undervoltage transients are observed on VDD5 and VSOUT1 rails (refer to [Device Behavior Under Slow VBAT Ramp-Up and Ramp-Down](#)).
- (5) The recommended maximum operating voltage for VBATP and VBAT_SAFING is listed as 34 V, just below the overvoltage detection thresholds for VBATP, $VBATP_OV_{rise}$ and $VBATP_OV_{fall}$. TI recommends enabling overvoltage detection on VBATP (default is enabled, MASK_VBATP_OV = 0). TI also recommends evaluating the thermal and power dissipation of the device in the application and ensure the design has adequate thermal management for operation at the necessary supply voltage level.
- (6) The device will remain on if VBATP drops from 5.8V down to $VBATP_UV_{off}$ threshold or another voltage monitor detects an undervoltage on a specific rail and changes the device state. $VBAT_UV_{off}$ can be detected at 4.5 V but could be detected as low as 4.2 V. VBAT_SAFING has a supply high enough to power the VMON block and internal rail AVDD_VMON above AVDD_VMON_UV.

4.4 Thermal Information

THERMAL METRIC ⁽¹⁾		TPS65381A-Q1	UNIT
		DAP (HTSSOP)	
		32 PINS	
R _{θJA}	Junction-to-ambient thermal resistance	26.3	°C/W
R _{θJC(top)}	Junction-to-case (top) thermal resistance	14.1	°C/W
R _{θJB}	Junction-to-board thermal resistance	6	°C/W
ψ _{JT}	Junction-to-top characterization parameter	0.2	°C/W
ψ _{JB}	Junction-to-board characterization parameter	6.2	°C/W
R _{θJC(bot)}	Junction-to-case (bottom) thermal resistance	0.5	°C/W

(1) For more information about traditional and new thermal metrics, see the [Semiconductor and IC Package Thermal Metrics](#) application report.

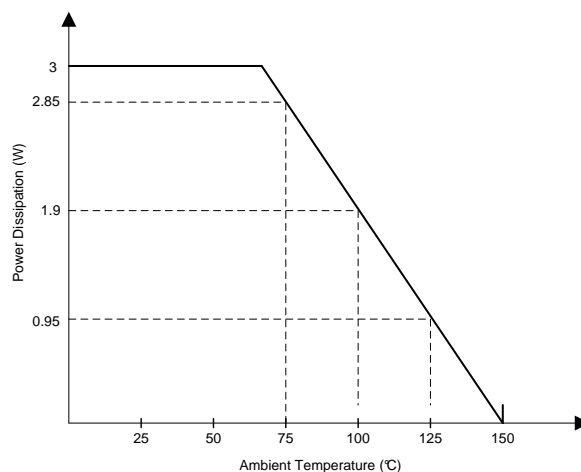

- (1) In applications where high power dissipation and/or poor package thermal resistance is present, the maximum ambient temperature may have to be derated. Maximum ambient temperature (T_{Amax}) is dependent on the maximum-operating junction temperature (T_{Jmax}), the maximum power dissipation of the device in the application (P_{Dmax}), and the junction-to-ambient thermal resistance of the part/package in the application ($R_{\theta JA}$), as given by the following equation: $T_{Amax} = T_{Jmax} - (R_{\theta JA} \times P_{Dmax})$.
- (2) Maximum power dissipation is a function of T_{Jmax} , $R_{\theta JA}$, and T_A . The maximum-allowable power dissipation at any allowable ambient temperature is $P_D = (T_{Jmax} - T_A) / R_{\theta JA}$.

Figure 4-1. Derating Profile for Power Dissipation Based on High-K JEDEC PCB

4.5 Electrical Characteristics

Over operating ambient temperature $T_A = -40^\circ\text{C}$ to the maximum-operating junction temperature $T_J = 150^\circ\text{C}$, and with $\text{VBATP} = \text{VBAT_SAFING}$ in the recommended operating range (see R1.2 in [Section 4.3](#)) (unless otherwise noted)

POS	PARAMETER		TEST CONDITIONS	MIN	TYP	MAX	UNIT
VDD6-BUCK WITH INTERNAL FET							
AN	C_{VDD6}	Value of output ceramic capacitor ⁽¹⁾	ESR range 100 m Ω to 300 m Ω ⁽²⁾	22		47	μF
AN	L_{VDD6}	Value of inductor		22	33		μH
1.1	VDD6	VDD6 output voltage	Average DC value excluding ripple and load transients, $\text{VBAT} > 7\text{ V}$, $0 < I_{VDD6} < 1.3\text{ A}$, including dc line and load regulation, temperature drift, and long-term drift where $\text{VBAT} = \text{VBATP} = \text{VBAT_SAFING}$	5.4	6	6.6	V
1.1a	$V_{DD6\text{ripple}}$	VDD6 ripple voltage	Peak-to-peak, ensured by design $\text{VBATP} = \text{VBAT_SAFING} = 14\text{ V}$, $L = 33\ \mu\text{H}$, $C = 22\ \mu\text{F}$		200		mV
1.2	I_{VDD6}	VDD6 output current $I_{VDD5} + I_{VDD3/5} + I_{VDD1} + I_{VSOUT1}$ ⁽³⁾				1.3	A
1.3	V_{dropout6}	VDD6 output dropout voltage $V_{\text{dropout6}} = (\text{VBATP} - \text{SDN6})$	$I_{VDD6} = 1.3\text{ A}$ (example: $R_{DS(on)} = 0.46\ \Omega$)			0.6	V
1.4	I_{VDD6_limit}	Peak current out of SDN6 pin ⁽⁴⁾		1.5		2.5	A
1.5	$f_{\text{clk_VDD6}}$	Clock Frequency ⁽⁵⁾		396	440	484	kHz
1.6	DC_{VDD6}	t_{on}/t_{period}	$0 < I_{VDD6} < 1.3\text{ A}$ VDD6 enters dropout mode (100% duty cycle) for $\text{VBATP} < 7\text{ V}$	7% ⁽⁶⁾		100%	
1.7	T_{protVDD6}	Temperature protection threshold ⁽⁷⁾		175		210	$^\circ\text{C}$
VDD5 – LDO WITH INTERNAL FET							
AN	C_{VDD5}	Value of output ceramic capacitor	ESR range 0 m Ω to 100 m Ω	1		5	μF
2.1	VDD5	VDD5 output voltage ⁽⁸⁾	$0 < I_{VDD5} < 300\text{ mA}$	4.9	5	5.1	V
2.2	I_{VDD5}	VDD5 output current, including load from the internal resistor of 660 Ω (typical)				300	mA
2.3	$V_{DD5\text{dyn}}$	VDD5 output voltage dynamic	Load step 20% to 80% in 5 μs , with $C_{VDD5} = 5\ \mu\text{F}$	4.85	5	5.15	V
2.4	$V_{DD5\text{max}}$	Maximum VDD5 output voltage during VBATP step from 5.5 V to 13.5 V within 10 μs	$C_{VDD5} = 5\ \mu\text{F}$, $I_{VDD5} < 300\text{ mA}$			5.5	V
2.5	V_{dropout5}	VDD5 output dropout voltage $V_{\text{dropout5}} = (\text{VDD6} - \text{VDD5})$	$I_{VDD5} < 300\text{ mA}$			0.3	V
2.6	PSRR_{VDD5}	Power supply rejection ratio	$50 < f < 20\text{ kHz}$, $\text{VBATP} = 10\text{ V}$, $U = 4\text{ Vpp}$, $C_{VDD5} = 5\ \mu\text{F}$, $0 < I_{VDD5} < 300\text{ mA}$		> 40		dB
2.7	LnReg_{VDD5}	Line regulation (I_{VDD5} constant)	$0 < I_{VDD5} < 300\text{ mA}$, $8\text{ V} < \text{VBATP} < 19\text{ V}$	-25		25	mV
2.8	LdReg_{VDD5}	Load regulation (VDD6 constant)	$0 < I_{VDD5} < 300\text{ mA}$, $8\text{ V} < \text{VBATP} < 19\text{ V}$	-25		25	mV
2.9	TmpCo_{VDD5}	Temperature drift	Normalized to 25 $^\circ\text{C}$ value	-0.5%		0.5%	
2.11	$dVDD5/dt$	dV/dt at VDD5 at startup	Between 10% and 90% of VDD5 end-value	5		50	V/ms
2.13	T_{protVDD5}	Temperature protection threshold ⁽⁹⁾		175		210	$^\circ\text{C}$
2.14	I_{VDD5_limit}	Current-limit ⁽¹⁰⁾		350		650	mA

- (1) Capacitance is effective capacitance after derating for operating voltage, temperature, and lifetime.
- (2) ESR is total effective series resistance of the capacitors and if necessary added series resistor.
- (3) I_{VDD6} is the load current from VDD5, VDD3/5, VDD1 and VSOUT1 on VDD6 regulator; VDD6 is not recommended to be loaded directly for applications or peripherals that cannot operate with wider tolerance and ripple since VDD6 is a pre-regulator. However, LDOs or DC-DC converters may be connected directly as long as the total load current on VDD6, I_{VDD6} , does not exceed the specification for VDD6 load current.
- (4) VDD6 current limit is based on the peak current through SDN6 switch, it will not directly correspond to an average current limit.
- (5) Actual switching on SDN6 depends on whether output voltage on VDD6 is above or below hysteretic PWM comparator threshold at the moment of the rising edge of the $F_{\text{clk_VDD6}}$ clock. If no switching is needed when the rising edge of the $F_{\text{clk_VDD6}}$ clock occurs, SDN6 will not switch on. SDN6 turn off is determined by the hysteretic PWM comparator threshold, when the actual VDD6 voltage is above the threshold SDN6 will turn off.
- (6) When the VDD6 control loop turns the SDN6 switch on at the rising edge of a $f_{\text{clk_VDD6}}$ clock cycle, SDN6 will remain on with a minimum duty cycle of 7%. However, if the control loop skips a clock cycle the duty cycle will be 0% for that $f_{\text{clk_VDD6}}$ clock cycle.
- (7) Protection of VDD6, shared with VDD3/5 overtemperature protection.
- (8) VDD5 output regulation includes line and load regulation, temperature drift.
- (9) Protection of VDD5. In case of detected overtemperature, only VDD5 will be switched off.
- (10) I_{VDD5_limit} current limit has snap back behavior. During a short circuit condition, a transient current higher than the maximum will occur until the current limit snaps back into the specified range.

Electrical Characteristics (continued)

Over operating ambient temperature $T_A = -40^\circ\text{C}$ to the maximum-operating junction temperature $T_J = 150^\circ\text{C}$, and with $V_{B\text{ATP}} = V_{\text{BAT_SAFING}}$ in the recommended operating range (see R1.2 in [Section 4.3](#)) (unless otherwise noted)

POS	PARAMETER		TEST CONDITIONS	MIN	TYP	MAX	UNIT	
VDD3/5 – LDO WITH INTERNAL FET								
AN	$C_{\text{VDD3/5}}$	Value of output ceramic capacitor	ESR range 0 m Ω to 100 m Ω	1		5	μF	
3.1a	VDD3/5	VDD3/5 output voltage, SEL_VDD3/5 pin: open = 3.3 V setting, ground = 5 V setting	0 < $I_{\text{VDD3/5}} < 300$ mA	3.3-V Setting	3.234	3.3	3.366	V
3.1b				5-V Setting	4.9	5	5.1	
3.2	$I_{\text{VDD3/5}}$	VDD3/5 output current, including load from the internal resistor of 440 Ω (typ.) for 3.3 V setting or 660 Ω (typ.) for 5 V setting ⁽¹¹⁾				300	mA	
3.3a	VDD3/5 _{dyn}	VDD3/5 output voltage dynamic	Load step 20% to 80% in 5 μs , with $C_{\text{VDD3/5}} = 5$ μF	3.3-V Setting	3.15	3.3	3.43	V
3.3b				5-V Setting	4.85	5	5.15	
3.4	VDD3/5 _{max}	Maximum VDD3/5 output voltage during VBATP step from 5.5 V to 13.5 V within 10 μs	$C_{\text{VDD3/5}} = 5$ μF , $I_{\text{VDD3/5}} < 300$ mA				3.6	V
							5.5	
3.5	Vdropout3/5	VDD3/5 output dropout voltage Vdropout3/5 = (VDD6–VDD3/5)	$I_{\text{VDD3/5}} < 300$ mA				0.3	V
3.6	PSRR _{VDD3/5}	Power-supply rejection ratio	50 < f < 20 kHz, VBATP = 10 V, U = 4 Vpp $C_{\text{VDD3/5}} = 5$ μF , 0 < $I_{\text{VDD3/5}} < 300$ mA		> 40			dB
3.7	LnReg _{VDD3/5}	Line regulation (I_{VDD3} constant)	0 < $I_{\text{VDD3/5}} < 300$ mA, 8 V < VBATP < 19 V		–25		25	mV
3.8	LdReg _{VDD3/5}	Load regulation (VDD6 constant)	0 < $I_{\text{VDD3/5}} < 300$ mA 8 V < VBATP < 19 V		–25		25	mV
3.9	TmpCo _{VDD3/5}	Temperature drift	Normalized to 25°C value		–0.5%		0.5%	
3.11	dVDD35/dt	dV/dt at VDD3/5 at start-up	Between 10% and 90% of VDD3/5 end-value	3.3-V Setting	3		30	V/ms
				5-V Setting	5		50	
3.13	Tprot _{VDD3/5}	Temperature protection threshold ⁽¹²⁾			175		210	°C
3.14	$I_{\text{VDD3/5_limit}}$	Current-limit ⁽¹³⁾			350		650	mA
3.15	$I_{\text{pu_SEL_VDD3/5}}$	Pullup current on SEL_VDD3/5 pin					20	μA
VDD1 – LDO WITH EXTERNAL FET								
AN	Vgs(th)	Gate threshold voltage, external FET	ID = 1 mA	0.3			3	V
AN	Ciss	Gate capacitance, external FET	VGS = 0 V				3200	pF
AN	Qgate	Gate Charge, external FET	VGS = 0 V to 10 V				70	nC
AN	gfs	Forward transconductance, external FET	ID = 50 mA	0.4				S
AN	C_{VDD1}	Value of output ceramic capacitor	ESR range 0 m Ω to 100 m Ω	5			40	μF
4.1	VDD1	VDD1 output voltage, depends on external resistive divider		0.8			3.3	V
4.2	VDD1 _{SENSE}	VDD1 reference voltage ⁽¹⁴⁾	10 mA < $I_{\text{VDD1}} < 600$ mA	0.792	0.8	0.808		V
4.2a	VDD1 _{SENSE_BIAS}	Bias current of VDD1 _{SENSE}		–6.6			–10	μA
4.3	I_{VDD1}	VDD1 output current	Minimum current realized with external resistive divider	10			600	mA
4.4	VDD1 _G	VDD1 _G output voltage	Referenced to GND				15	V
4.5	VDD1 _{G_off}	VDD1 _G voltage in OFF condition	20 μA into VDD1 _G pin				0.3	V
4.6	I_{VDD1G}	VDD1 _G DC load current					200	μA
4.7	VDD1 _{dyn}	VDD1 output voltage dynamic	Load step 10% to 90% in 1 μs , with $C_{\text{VDD1}} = 40$ μF ⁽¹⁵⁾				± 4%	
4.8	VDD1 _{max}	Maximum VDD1 output voltage during VBATP step from 5.5 V to 13.5 V within 10 μs	$C_{\text{VDD1}} > 6$ μF , $I_{\text{VDD1}} < 600$ mA					V
				VDD1 = 0.8-V output			0.898	
				VDD1 = 1.23-V output			1.287	
				VDD1 = 3.3-V output			3.435	
4.9	PSRR _{VDD1}	Power-supply rejection ratio	50 < f < 20 kHz, VBATP = 10 V, U = 4 Vpp, $C_{\text{VDD1}} = 10$ μF , 10 mA < $I_{\text{VDD1}} < 600$ mA		> 40			dB
4.10	LnReg _{VDD1}	Line regulation on VDD1 _{SENSE} (I_{VDD1} constant)	10 mA < $I_{\text{VDD1}} < 600$ mA, 8 V < VBATP < 19 V		–7		7	mV
4.11	LdReg _{VDD1}	Load regulation on VDD1 _{SENSE} (VDD6 constant)	10 mA < $I_{\text{VDD1}} < 600$ mA, 8 V < VBATP < 19 V		–7		7	mV
4.12	TmpCo _{VDD1}	Temperature drift	Normalized to 25°C value		–0.5%		0.5%	
4.14	dVDD1/dt	dV/dt at VDD1 _{SENSE} at start-up	Between 10% and 90% of VDD1 end-value		0.8			8
VSOUT1 – LDO WITH PROTECTED INTERNAL FET								

(11) Less than 50% of maximum loading of $I_{\text{VDD3/5}}$ should be placed on the VDD3/5 regulator before NRES goes high during device power up.

(12) Protection of VDD3/5, treated as global overtemperature (shutdown for all regulators).

(13) $I_{\text{VDD3/5_limit}}$ current limit has snap back behavior. During a short circuit condition, a transient current higher than the maximum will occur until the current limit snaps back into the specified range.

(14) VDD1 regulation including line and load regulation, temperature drift and long-term drift. Does not include tolerance of resistor divider to set VDD1 output voltage.

(15) VDD1_{dyn} will depend on external FET choice

Electrical Characteristics (continued)

Over operating ambient temperature $T_A = -40^\circ\text{C}$ to the maximum-operating junction temperature $T_J = 150^\circ\text{C}$, and with $V_{BATP} = V_{BAT_SAFING}$ in the recommended operating range (see R1.2 in Section 4.3) (unless otherwise noted)

POS	PARAMETER		TEST CONDITIONS	MIN	TYP	MAX	UNIT
AN	C_{VSOUT1}	Value of output ceramic capacitor	ESR range 0 mΩ to 100 mΩ	0.5		10	μF
5.1	VSOUT1	VSOUT1 output voltage, depends on external resistive divider and tracking or non-tracking mode		3.3		9.5	V
5.2	MV_{VSOUT1}	For tracking mode: Matching output error $MV_{VSOUT1} = (VTRACK1 - VSFB1)^{(16)}$	$0 < I_{VSOUT1} < 100\text{ mA}$	-35		35	mV
5.3	VSFB1	For non-tracking mode: VSOUT1 reference voltage ⁽¹⁷⁾	$10\text{ mA} < I_{VSOUT1} < 100\text{ mA}$	2.45	2.5	2.55	V
5.3a	$VTRACK1_{th}$	Threshold for selecting tracking/non-tracking mode ($VTRACK1 > VTRACK1_{th_max}$ V for tracking mode, $VTRACK1 < VTRACK1_{th_min}$ V non-tracking mode)		1.1	1.2	1.3	V
5.3b	$VTRACK1_{pd}$	Internal pulldown resistance on VTRACK1 pin			100		kΩ
5.4	I_{VSOUT1}	VSOUT1 output current, including internal resistor to dissipate minimum current ⁽¹⁸⁾				100	mA
5.5	VdrS1	VSOUT1 dropout voltage $VdrS1 = (VSIN - VSOUT1)$	$0 < I_{VSOUT1} < 100\text{ mA}$			0.75	V
5.6	$PSRR_{VSOUT1}$	Power-supply rejection ratio	With $VTRACK1 = GND$, $VSOUT1 = 4.5\text{ V}$, $50 < f < 20\text{ kHz}$, $VSIN = 10\text{ V}$, $U = 4\text{ Vpp}$, $C_{VSOUT1} = 1\text{ μF}$, $0 < I_{VSOUT1} < 100\text{ mA}$,		> 40		dB
5.7	$LnReg_{VSOUT1}$	Line regulation (I_{VSOUT1} constant)	$0 < I_{VSOUT1} < 100\text{ mA}$, $8\text{ V} < VSIN < 19\text{ V}$	-25		25	mV
5.8	$LdReg_{VSOUT1}$	Load regulation (VSIN constant)	$0 < I_{VSOUT1} < 100\text{ mA}$, $8\text{ V} < VSIN < 19\text{ V}$	-35		35	mV
5.9	$TmpCo_{VSOUT1}$	Temperature drift	Normalized to 25°C value	-0.5%		0.5%	
5.11	$VSOUT1_{SH}$	Output short circuit voltage range	VSOUT1 (VSFB1 configured for regulation) ⁽¹⁹⁾	-2		18	V
5.12	$-I_{VSIN}$	Output reverse current	VSOUT1 = 14 V and $V_{BATP} = 0\text{ V}$, regulator switched off			20	mA
5.13	$T_{protVSOUT1}$	Temperature protection threshold ⁽²⁰⁾		175		210	°C
5.14	I_{VSOUT1_limit}	Current-limit		120		500	mA
VOLTAGE MONITORING							
6.1	$VBATP_UV_{off}$	$VBATP$ and $VBAT_SAFING$ level for indication by $VBAT_UV$ comparator ⁽²¹⁾	$VBATP = V_{BAT_SAFING}$	4.2		4.5	V
6.2	$VBATP_UV_{on}$	$VBATP$ and $VBAT_SAFING$ level for indication by $VBAT_UV$ comparator ⁽²¹⁾	$VBATP = V_{BAT_SAFING}$	5.4		5.8	V
6.3	$VBATP_UV_{hys}$	Undervoltage hysteresis	$VBATP = V_{BAT_SAFING}$	1.1		1.4	V
6.4	$VBATP_OV_{rise}$	$VBATP$ level for setting $VBAT_OV$ flag ⁽²²⁾	$VBATP = V_{BAT_SAFING}$	34.7		36.7	V
6.5	$VBATP_OV_{fall}$	$VBATP$ level for clearing $VBAT_OV$ flag ⁽²³⁾	$VBATP = V_{BAT_SAFING}$	34.4		36.3	V
6.8	$VDD5_UV$	VDD5 undervoltage level	$VBATP = V_{BAT_SAFING}$	4.5		4.85	V
6.8a		Hysteresis	$VBATP = V_{BAT_SAFING}$		140		mV
6.9	$VDD5_UV_{head}$	VDD5 undervoltage headroom ($VDD5_{act} - VDD5_UV_{act}$)	$VBATP = V_{BAT_SAFING}$	200			mV
6.10	$VDD5_OV$	VDD5 overvoltage level	$VBATP = V_{BAT_SAFING}$	5.2		5.45	V
6.10a		Hysteresis	$VBATP = V_{BAT_SAFING}$		140		mV
6.11	$VDD5_OV_{head}$	VDD5 overvoltage headroom ($VDD5_OV_{act} - VDD5_{act}$)	$VBATP = V_{BAT_SAFING}$	200			mV
6.12	$VDD3/5_UV$	VDD3/5 undervoltage level	$VBATP = V_{BAT_SAFING}$	3.3-V setting	3	3.17	V
				5-V setting	4.5	4.85	
6.12a	$VDD3/5_UV$	Hysteresis	$VBATP = V_{BAT_SAFING}$	3.3-V setting	100		mV
				5-V setting	140		
6.13	$VDD3/5_UV_{head}$	VDD3/5 undervoltage headroom ($VDD3/5_{act} - VDD3/5_UV_{act}$)	$VBATP = V_{BAT_SAFING}$	3.3-V setting	155		mV
				5-V setting	200		

- (16) Referenced to VTRACK1 input, including long-term and temperature drift.
- (17) VSOUT1 including line and load regulation, temperature drift and long-term drift.
- (18) VSOUT1 maximum power dissipation for the internal FET must not exceed 0.6 W to avoid overtemperature. Special consideration must be taken for output voltages greater than 5 V and when V_{BATP} is used to supply VSIN instead of VDD6.
- (19) VSOUT1 is connected to VSFB1 directly (for unity gain) or through resistor divider (tracking mode gain or non-tracking mode output voltage adjusting). In case of a short to supply fault, the voltage on VSOUT1 is equal to the supply to the device (V_{BATP} , V_{BAT_SAFING} , and VSIN where VSIN is connected to V_{BATP} as its supply instead of VDD6) and VSFB1 voltage will follow VSOUT1 based on the use case, directly (for unity gain) or via resistor divider (tracking mode gain or non-tracking mode output voltage adjusting).
- (20) Protection of VSOUT1 Sensor Supply. Only VSOUT1 switch-offs off.
- (21) $VBATP_UV_{off}$ and $VBATP_UV_{on}$ are the threshold levels for V_{BATP} where UV will be indicated by the $VBAT_UV$ bit in $VMON_STAT_1$ register. The V_{BATP} level that will allow device power up is outlined by R1.1.
- (22) Brings device into the RESET state and sets flag in SPI
- (23) Clears flag in SPI

Electrical Characteristics (continued)

Over operating ambient temperature $T_A = -40^\circ\text{C}$ to the maximum-operating junction temperature $T_J = 150^\circ\text{C}$, and with $\text{VBATP} = \text{VBAT_SAFING}$ in the recommended operating range (see R1.2 in Section 4.3) (unless otherwise noted)

POS	PARAMETER		TEST CONDITIONS	MIN	TYP	MAX	UNIT	
6.14	VDD3/5_OV	VDD5_3 overvoltage level	VBATP = VBAT_SAFING	3.3-V setting	3.43	3.6	V	
				5-V setting	5.2	5.5		
6.14a		Hysteresis	VBATP = VBAT_SAFING		100		mV	
					140			
6.15	VDD3/5_UVhead	VDD3/5 undervoltage headroom (VDD3/5_OVact – VDD3/5act)	VBATP = VBAT_SAFING	3.3-V setting	170		mV	
					5-V setting	200		
6.16	VDD1_UV	VDD1 undervoltage level	VBATP = VBAT_SAFING. Sensed on VDD1_SENSE pin. Relative thresholds are with respect to nominal 800-mV VDD1_SENSE (Pos 4.2)		752	784	mV	
6.16a		Hysteresis				10		
6.17	VDD1_OV	VDD1 overvoltage level	VBATP = VBAT_SAFING. Sensed on VDD1_SENSE pin. Relative thresholds are with respect to nominal 800-mV VDD1_SENSE (Pos 4.2)		816	848	mV	
6.17a		Hysteresis				9		
6.19	VSOUT1_UV	VSOUT1 undervoltage level	Sensed on VFSB1 pin. Relative thresholds (ratio) are: <ul style="list-style-type: none"> For non-tracking mode, with respect to nominal 2.5-V VFSB1 (Pos 5.3) For tracking mode, with respect to voltage applied on VTRACK1 pin In tracking mode, VSOUT1_UV comparator output is valid for VTRACK1 DC condition 		0.88	0.94	VSOUT1	
6.20	VSOUT1_OV	VSOUT1 overvoltage level	Sensed on VFSB1 pin. Relative thresholds (ratio) are: <ul style="list-style-type: none"> For non-tracking mode, with respect to nominal 2.5-V VFSB1 (Pos 5.3) For tracking mode, with respect to voltage applied on VTRACK1 pin In tracking mode, VSOUT1_OV comparator output is valid for VTRACK1 DC condition 		1.06	1.12	VSOUT1	
6.22	VDD6_UV	VDD6 undervoltage level ⁽²⁴⁾			5.2	5.4	V	
6.22a		Hysteresis				115		mV
6.23	VDD6_OV	VDD6 overvoltage level ⁽²⁴⁾			7.8	8.2	V	
6.23a		Hysteresis				115		mV
IGNITION AND CAN WAKE-UP								
7.1	IGN_WUP	IGN wake-up threshold ⁽²⁵⁾	VBATP = VBAT_SAFING = 12 V		2	3	V	
7.2	CAN_WUP	CAN wake-up threshold ⁽²⁵⁾	VBATP = VBAT_SAFING = 12 V		2	3	V	
7.3	WUP_hyst	Wake-up hysteresis	VBATP = VBAT_SAFING = 12 V		50	200	mV	
7.4	I_IGN	IGN pin forward leakage current	IGN pin at 36 V, VBATP = VBAT_SAFING = 12V			50	μA	
7.5	I_IGN_rev	IGN reverse current	IGN at -7 V, VBATP = VBAT_SAFING = 12 V		-1		mA	
7.7	I_CANWU	CANWU pin forward leakage current	CANWU pin at 36 V, VBATP = VBAT_SAFING = 12V			50	μA	
7.8	I_CAN_rev	CANWU reverse current	CANWU at -0.3 V, VBATP = VBAT_SAFING = 12 V				mA	
CHARGE PUMP								
AN	C _{pump}	Pumping capacitor (between CP1 and CP2)			10		nF	
AN	C _{store}	Storage capacitor (between VCP and VBATP)			100		nF	
8.1	VCP _{on}	VCP output voltage in on-state	VBATP > 5.8 V		VBATP + 4	VBATP + 15	V	
8.2	I _{CP}	External load	Load coming from R _{CS} of Reverse Battery Protection			100	μA	
8.3	f _{CP}	Charge-pump switching frequency			225	250	275	kHz
RESET AND ENABLE OUTPUTS								
9.1	V _{NRES_ENDRV_L}	NRES / ENDRV low-output level	With external 2-mA open-drain current			0.2	V	
9.2	R _{NRES_ENDRV_PULLUP}	NRES / ENDRV internal pullup resistance			3	6	k Ω	
9.2a	R _{DS(on)_ENDRV_NRES}	R _{DS(on)} NRES/ENDRV pulldown transistor				40	Ω	
9.3	R _{RSTEXT}	Value of external reset extension resistor, in case of open-connect, device stays in RESET state ⁽²⁶⁾			0	22	k Ω	

(24) Information in SPI register only

(25) For device wake up, VBATP and VBAT_SAFING must be operating range, Recommended Operating Conditions R1.1 and R1.3a, and then a level on either IGN or CANWU to allow the device to start up, especially when VBATP and VBAT_SAFING are ramping.

(26) The maximum resistance recommend for RSTEXT to ground is 120 k Ω .

Electrical Characteristics (continued)

Over operating ambient temperature $T_A = -40^\circ\text{C}$ to the maximum-operating junction temperature $T_J = 150^\circ\text{C}$, and with $\text{VBATP} = \text{VBAT_SAFING}$ in the recommended operating range (see R1.2 in [Section 4.3](#)) (unless otherwise noted)

POS	PARAMETER		TEST CONDITIONS	MIN	TYP	MAX	UNIT
9.5	$V_{\text{ENDRV_NRES_TH}}$	ENDRV and NRES input readback logic 1 threshold	Read-back muxed to DIAG_OUT pin	350	400	450	mV
DIGITAL INPUT / OUTPUT							
10.1	$V_{\text{DIGIN_HIGH}}$	Digital input, high level for NCS, SDI, SCLK, ERROR/WDI and SEL_VDD3/5		2			V
10.2	$V_{\text{DIGIN_LOW}}$	Digital input, low level for NCS, SDI, SCLK, ERROR/WDI and SEL_VDD3/5				0.8	V
10.3	$V_{\text{DIGIN_HYST}}$	Digital input hysteresis for NCS, SCL, SCLK and ERROR/WDI ⁽²⁷⁾		0.1			V
10.4	$R_{\text{DIAGOUT_AMUX}}$	Output resistance at DIAG_OUT pin in AMUX mode	BG1 selected on AMUX, < 200 nA current in or out of DIAG_OUT pin			15	k Ω
10.5	$V_{\text{DIGOUT_HIGH}}$	Digital output, high level ⁽²⁸⁾	$I_{\text{OUT}} = -2$ mA (out of pin)	VDDIO – 0.2			V
10.6	$V_{\text{DIGOUT_LOW}}$	Digital output, low level ⁽²⁸⁾	$I_{\text{OUT}} = 2$ mA (into pin)			0.2	V
SERIAL PERIPHERAL INTERFACE							
13.12	$R_{\text{PULL_UP}}$	Internal pullup resistor on NCS input pin		40	70	100	k Ω
13.13	$R_{\text{PULL_DOWN}}$	Internal pulldown resistor on SDI and SCLK input pins		40	70	100	k Ω

(27) SEL_VDD3/5 is sampled and latched at device power up hysteresis, $V_{\text{DIGIN_HYST}}$, does not apply.

(28) For pins SDO and DIAG_OUT in DMUX mode.

4.6 Timing Requirements

Over operating ambient temperature $T_A = -40^\circ\text{C}$ to the maximum-operating junction temperature $T_J = 150^\circ\text{C}$, and $\text{VBATP} = \text{VBAT_SAFING}$ in the recommended operating range (see R1.2 in the [Section 4.3](#)) (unless otherwise noted)

POS			MIN	NOM	MAX	UNIT	
VDD5 – LDO WITH INTERNAL FET							
2.12	$t_{\text{delayVDD5}}$	VDD5 voltage stabilization delay	Maximum delay between rising edge on CANWU pin until VDD5 reaches the end-value within 2%		5	ms	
VDD3/5 – LDO WITH INTERNAL FET							
3.12	$t_{\text{VDD3/5}}$	VDD3/5 voltage stabilization delay	Maximum delay after CANWU wakeup for VDD3/5 output to settle		5	ms	
VDD1 – LDO WITH EXTERNAL FET							
4.15	$t_{\text{delayVDD1}}$	VDD1 voltage stabilization delay	Maximum delay after CANWU wakeup for VDD1 output to settle		5	ms	
VOLTAGE MONITORING							
6.7	VBATP_deglitch	VBATP undervoltage and overvoltage monitor deglitch time	180	240 ⁽¹⁾	260	μs	
6.18	VDDx_deglitch	VDDx undervoltage and overvoltage monitor deglitch time	10		40	μs	
6.21	VSOUT1_deglitch	VSOUT1 undervoltage and overvoltage monitor deglitch time	10		40	μs	
IGNITION AND CAN WAKE-UP (IGN AND CANWU)							
7.6	IGN_deg	IGN deglitch filter time	7.5		22	ms	
7.9	CANWU_deg	CANWU deglitch filter time	100		350	μs	
RESET AND ENABLE OUTPUTS							
9.4	$t_{\text{RSTEXT(22k}\Omega)}$	Reset extension delay	22 k Ω	4.05	4.5	4.95	ms
9.4a	$t_{\text{RSTEXT(0k}\Omega)}$	Reset extension delay	0 k Ω	0.98	1.4	1.89	ms
INTERNAL SYSTEM CLOCK							
11.1	f_{Sysclk}	System clock frequency ⁽²⁾	3.8	4	4.2	MHz	
WINDOW WATCHDOG							
12.2	$t_{\text{WD_pulse}}$	Deglitch time on ERROR/WDI pin for watchdog-trigger input signal	14.25	30	32	μs	
SERIAL PERIPHERAL INTERFACE TIMING⁽³⁾							
13.1	f_{SPI}	SPI clock (SCLK) frequency	VDDIO = 3.3 V		5 ⁽⁴⁾	MHz	
			VDDIO = 5 V		6		

(1) 240 μs for VBAT-UV deglitch and 260 μs for VBAT-OV deglitch

(2) The system clock is also used to derive the clock for the watchdog timer, so the system clock tolerance also impacts the watchdog-timer tolerance.

(3) Capacitance at $C_{\text{SDO}} = 100$ pF

(4) MAX SPI Clock tolerance is $\pm 10\%$

Timing Requirements (continued)

Over operating ambient temperature $T_A = -40^\circ\text{C}$ to the maximum-operating junction temperature $T_J = 150^\circ\text{C}$, and $V_{BATP} = V_{BAT_SAFING}$ in the recommended operating range (see R1.2 in the [Section 4.3](#)) (unless otherwise noted)

POS			MIN	NOM	MAX	UNIT
13.2	t_{SPL}	SPI clock period	VDDIO = 3.3 V	200		ns
			VDDIO = 5 V	167		
13.3	t_{high}	High time: SCLK logic high duration	See Figure 4-2	85.7		ns
13.4	t_{low}	Low time: SCLK logic low duration		45		ns
13.5	t_{sucs}	Setup time NCS: time between falling edge of NCS and rising edge of SCLK		45		ns
13.7	t_{susi}	Setup time at SDI: setup time of SDI before the falling edge of SCLK		15		ns
13.9	t_{hcs}	Hold time: time between the falling edge of SCLK and rising edge of NCS		45		ns
13.10	t_{hics}	SPI transfer inactive time (time between two transfers) during which NCS must remain high		788		ns

4.7 Switching Characteristics

Over operating ambient temperature $T_A = -40^\circ\text{C}$ to the maximum-operating junction temperature $T_J = 150^\circ\text{C}$, and $V_{BATP} = V_{BAT_SAFING}$ in the recommended operating range (see R1.2 in [Section 4.3](#)) (unless otherwise noted)

POS	PARAMETER	TEST CONDITIONS	MIN	TYP	MAX	UNIT
Serial Peripheral Interface Timing⁽¹⁾						
13.6	t_{d1}	Delay time: time delay from falling edge of NCS to SDO transitioning from tri-state to 0	See Figure 4-2		53.3	ns
13.8	t_{d2}	Delay time: time delay from rising edge of SCLK to data valid at SDO		0	85.7	ns
13.11	t_{tri}	Tri-state delay time: time between rising edge of NCS and SDO in tri-state			53.3	ns

(1) Capacitance at $C_{SDO} = 100\text{ pF}$

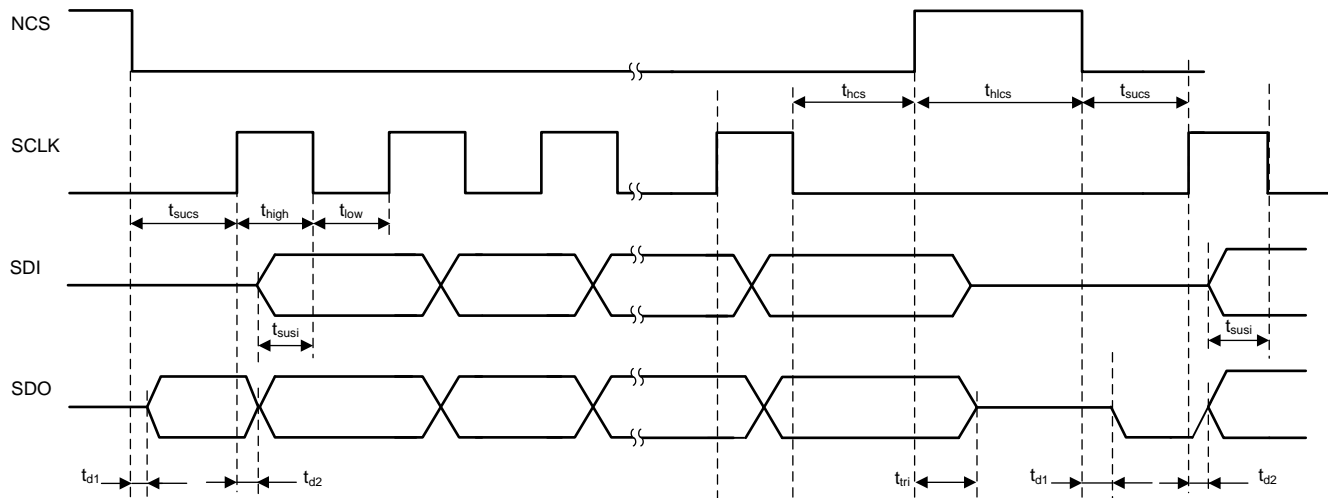

Figure 4-2. SPI Timing Parameters

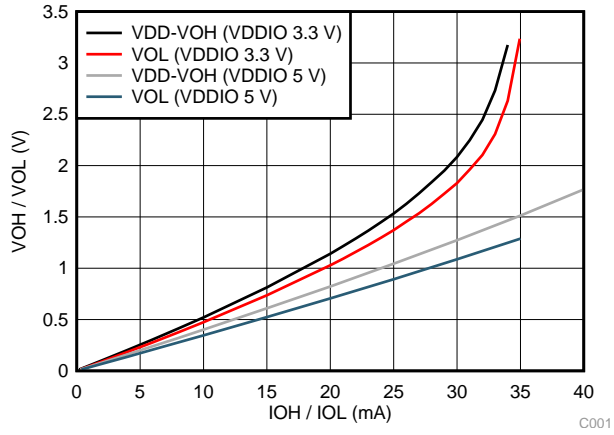

Figure 4-3. SPI SDO Buffer Source and Sink Current

4.8 Typical Characteristics

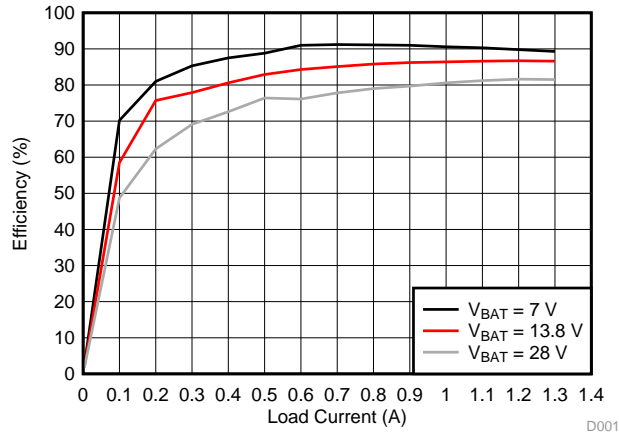

Figure 4-4. VDD6 BUCK Efficiency

5 Detailed Description

5.1 Overview

The device integrates an asynchronous-buck switch mode power-supply converter with an internal FET that converts the input battery voltage to a 6-V preregulator output, which supplies the integrated regulators.

A fixed 5-V linear regulator with an internal FET is integrated to be used as, for example, a CAN supply. A second linear regulator, also with an internal FET, regulates the 6 V to a selectable 5-V or 3.3-V MCU I/O voltage. A linear regulator controller with an external FET and resistor-divider regulates the 6 V to an externally adjustable core voltage of between 0.8 V and 3.3 V. A linear regulator with two different modes of operation (tracking mode and non-tracking mode) with adjustable voltage between 3.3 V and 9.5 V can be used as a supply for external sensor.

The device monitors undervoltage and overvoltage on all regulator outputs, battery voltage, and internal supply rails. A second band-gap reference, independent from the main band-gap reference used for regulation circuit, is used for undervoltage and overvoltage monitoring. In addition, regulator current-limits and temperature protections are implemented.

The device supports wakeup from IGNITION or wakeup from a CAN transceiver.

5.2 Functional Block Diagram

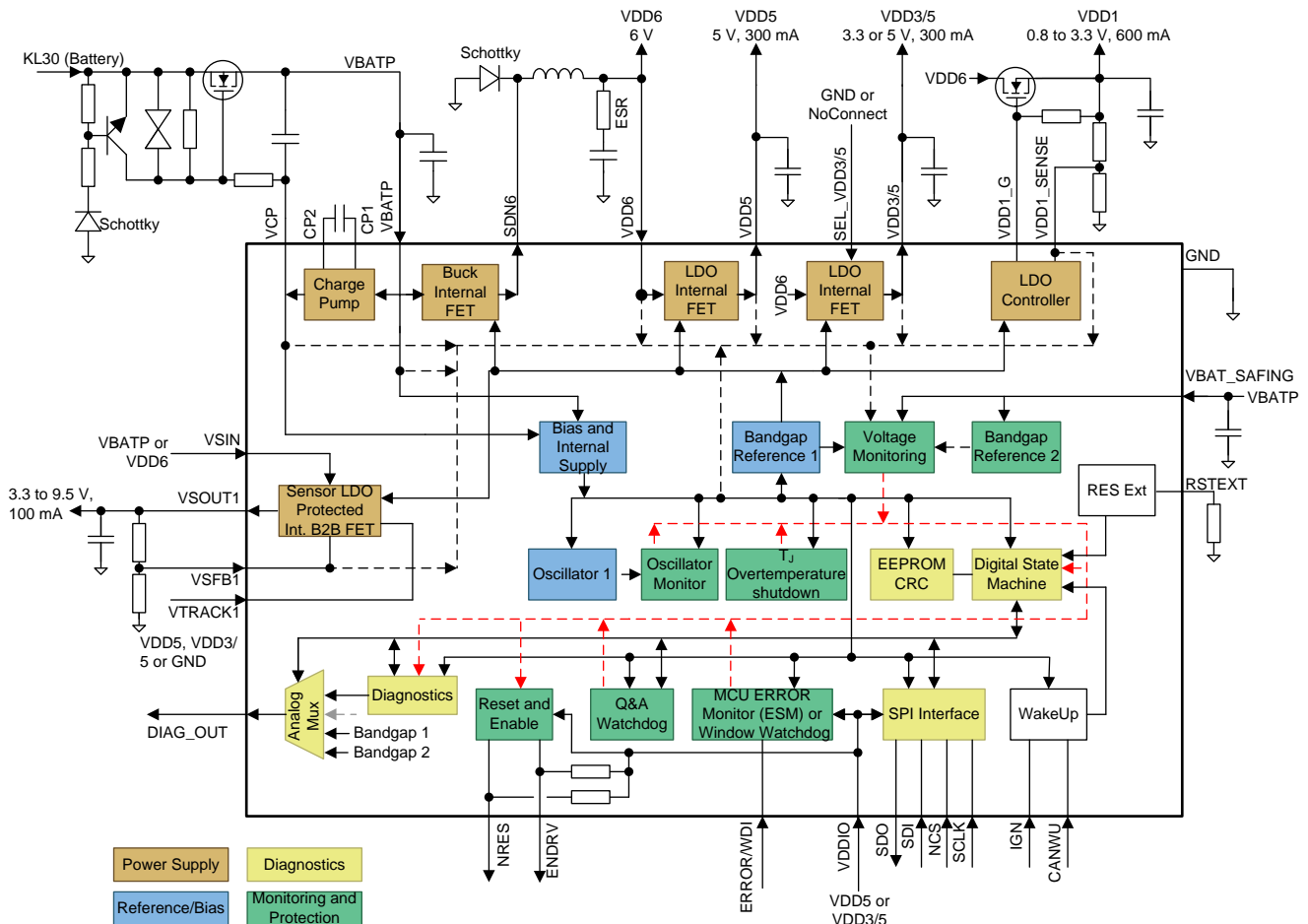

Copyright © 2017, Texas Instruments Incorporated

5.3 Feature Description

5.3.1 VDD6 Buck Switch-Mode Power Supply

The purpose of the VDD6 buck switch-mode power supply is to reduce the power dissipation inside the device as a preregulator. The VDD6 supply regulates from the battery voltage (main supply) range to 6 V. The VDD6 output is used as the input voltage for the VDD5, VDD3/5, VDD1, and can also be used for VSOUT1 regulator depending on the required VSOUT1 output voltage. The VDD6 supply is intended as a preregulator, therefore the output accuracy of VDD6 is less than the other integrated regulators. The VDD6 current capability is set to supply the VDD5, VDD3/5, VDD1, and VSOUT1 regulators at their respective maximum output currents. Power dissipation and thermal analysis should be performed to ensure the PCB design and thermal management can support the required power dissipation in the application.

This switch-mode power supply operates with fixed-frequency adaptive on-time control PWM. The control loop is based on a hysteretic comparator. The internal N-channel MOSFET is turned on at the beginning of each cycle if the sensed voltage on the VDD6 pin is below the hysteretic comparator threshold. When the MOSFET is turned on, it is on for a minimum of 7% duty cycle (7% of $f_{\text{clk_VDD6}}$). This MOSFET is turned off when the hysteretic comparator detects a voltage on the VDD6 pin above the threshold. The VDD6 regulator may skip pulses if the output voltage remains above the hysteretic comparator when the clock edge occurs. When the MOSFET is turned off, the external Schottky diode recirculates the energy stored in the inductor for the remainder of the switching period. The VDD6 regulator enters dropout mode (100% duty cycle) for a supply voltage below approximately 7 V on the VBATP pin.

The internal MOSFET is protected from excessive power dissipation by a current-limit circuit. The VDD6 regulator also shares an overtemperature protection circuit with the VDD3/5 regulator. When overtemperature is detected by this circuit, the device transitions to the STANDBY state (all regulators switched off).

Because the control loop of the VDD6 regulator is based on a hysteretic comparator, the effective capacitance on the output, and effective series resistance (ESR) of the output capacitance must be considered. The effective capacitance of the output capacitors at the operating voltage (6 V, DC bias derating), tolerance, temperature range, and lifetime must meet the effective capacitance range for VDD6 (C_{VDD6}). The capacitor supplier should provide the necessary derating data to calculate the effective capacitance. The hysteretic comparator also requires a specified ESR to ensure balanced operation. Typically low-ESR ceramic capacitors are used for the output, so an external resistor is required to bring the total ESR into the specified ESR range for the C_{VDD6} . A general guideline to achieve balanced operation is $R_{\text{ESR}} = L / (15 \times C_{\text{Effective}})$. Using a higher-effective output capacitance allows for a lower ESR, which leads to lower-voltage ripple. Additionally, the inductance influences the system: using a lower inductance value allows for lower ESR, however, the peak inductor current will be higher.

5.3.2 VDD5 Linear Regulator

The VDD5 pin is a regulated supply of 5 V $\pm 2\%$ overtemperature and battery supply range. A low-ESR ceramic capacitor is required for loop stabilization. This capacitor must be placed close to the pin of the device. This output is protected against shorts to ground by a current-limit. This output also limits output-voltage overshoot during power up and during line or load transients.

On an initial IGN or CANWU power cycle, the soft-start circuit on this regulator is initiated, which is typically from 1 ms to 2 ms. This output can require a larger output capacitor to ensure that during load transients the output does not drop below the required regulation specifications.

The internal MOSFET is protected from excess power dissipation with junction-overtemperature protection. In case of an overtemperature condition in the VDD5 pin, only the VDD5 regulator switches off by clearing bit D4 in the SENS_CTRL register. To re-enable the VDD5 pin, bit D4 in the SENS_CTRL register must be set again.

5.3.3 VDD3/5 Linear Regulator

The VDD3/5 pin is a regulated supply of 3.3 V or 5 V $\pm 2\%$ overtemperature and battery supply range. The output voltage level is selected with the SEL_VDD3/5 pin (open pin selects 3.3 V, grounded pin selects 5 V). The state of this selection pin is sampled and latched directly at the first initial IGN or CANWU power cycle. When latched, any change in the state of this selection pin after the first initial IGN or CANWU power cycle does not change the initially selected state of the VDD3/5 regulator.

A low-ESR ceramic capacitor is required for loop stabilization. This capacitor must be placed close to the pin of the device. This output is protected against shorts to ground by a current-limit. This output also limits output-voltage overshoot during power up or during line or load transients.

On an initial IGN or CANWU power cycle, the soft-start circuit on this regulator is initiated, which is typically from 1 ms to 2 ms. This output may require a larger output capacitor to ensure that during load transients the output does NOT drop below the required regulation specifications.

The internal MOSFET is protected from excess power dissipation with a current-limit circuit and junction overtemperature protection. In case of an overtemperature in the VDD3/5 pin, the TPS65381A-Q1 device enters the STANDBY state (all regulators switched-off).

5.3.4 VDD1 Linear Regulator

The VDD1 pin is an adjustable regulated supply from 0.8 V to 3.3 V. This regulator uses a $\pm 2\%$ reference (VDD1_{SENSE}). The tolerance of the external feedback resistor divider resistors have an impact to the overall VDD1 regulation tolerance. To reduce on-chip power consumption, an external power NMOS is used. The regulation loop and the command gate drive are integrated. TI recommends applying a resistor with a value of 100 k Ω to 1 M Ω between the gate and source of the external power NMOS. The VDD1 gate output is limited to prevent gate-source overvoltage stress during power up or during line or load transients.

On an initial IGN or CANWU power cycle, the soft-start circuit on this regulator is initiated, which is typically from 1 ms to 2 ms. This soft-start is meant to prevent any voltage overshoot at start-up. The VDD1 output may require larger output capacitor to ensure that during load transients the output does not drop below the required regulation specifications.

The VDD1 LDO has no current-limit and no overtemperature protection for the external NMOS FET. Therefore, supplying the VDD1 pin from the VDD6 pin is recommended (see [Section 5.2](#)). In this way, the VDD6 pin current-limit acts as current-limit for the VDD1 pin and the power dissipation is limited also. To avoid damage in the external NMOS FET, selecting the current rating of the VDD1 pin well above the maximum-specified VDD6 current-limit is recommended.

If the VDD1 regulator is not used, leave the VDD1_G and VDD1_SENSE pins open. An internal pullup device on the VDD1_SENSE pin detects the open connection and pulls up the VDD1_SENSE pin. This forces the regulation loop to bring the VDD1_G output down. This mechanism also masks the VDD1_OV flag in VMON_STAT_2 register and therefore the ENDRV pin action from a VDD1 overvoltage (OV) condition is also masked. These actions are equivalent to clearing the NMASK_VDD1_UV_OV bit in the DEV_CFG1 register to 0. This internal pullup device on the VDD1_SENSE pin also prevents a real VDD1 overvoltage on the MCU core supply in case of an open connection to the VDD1_SENSE pin, as it brings the VDD1_G pin down. Therefore, in this situation, the VDD1 output voltage is 0 V.

By default, VDD1 monitoring is disabled. If the VDD1 pin is used in the application, TI recommends to set the NMASK_VDD1_UV_OV bit in the DEV_CFG1 register to 1 when the device is in the DIAGNOSTIC state. This setting enables driving and extending the reset to the external MCU when a VDD1 undervoltage event is detected.

5.3.5 VSOUT1 Linear Regulator

The VSOUT1 regulator is a regulated supply with two separate modes: tracking mode and non-tracking mode. The mode selection occurs with the VTRACK1 pin. When the voltage applied on the VTRACK1 pin is above 1.2 V, the VSOUT1 pin is in tracking mode. When the VTRACK1 pin is shorted to ground, the VSOUT1 regulator is in non-tracking mode. This mode selection occurs during the first ramp-up of the VDDx rails and is latched after the first VDDx ramp-up is complete. Therefore, after completion of the VDDx ramp-up, any change on the VTRACK1 pin no longer affects the selected tracking or non-tracking mode.

In tracking mode, the VSOUT1 regulator tracks the input reference voltage on the VTRACK1 pin with a gain factor determined by the external resistive divider. The tracking offset between the VTRACK1 and VSFB1 pins is ± 35 mV. This mode allows, for instance, the VSOUT1 output voltage to be 5 V while tracking the VDD3 (3.3-V) supply. In unity-gain feedback, the VSOUT1 output voltage can directly follow the VDD5 pin or the VDD3 pin.

In non-tracking mode, the VSOUT1 output voltage is proportional to a fixed reference voltage of 2.5 V at the VSFB1 pin, with a gain factor determined by the external resistive divider. This mode allows the VSOUT1 pin to be any factor of the internal reference voltage.

Both in tracking and non-tracking mode, the VSOUT1 output voltage must be 3.3 V or higher. The VSOUT1 regulator can track the VDD3/5 pin in 3.3-V setting within the specified limits.

The VSOUT1 regulator has a separate input supply to reduce the internal power dissipation. For an output voltage of 3.3 V or 5 V, for instance, the VDD6 supply can be used as the input supply. For an output voltage greater than 5 V, the VBATP pin can be used as the input supply. The maximum power dissipation for the internal FET must not exceed 0.6 W to avoid overtemperature (thermal shutdown).

A low-ESR ceramic capacitor is required for loop stabilization; this capacitor must be placed close to the pin of the device. This supply limits output-voltage overshoot during power up or during line or load transients.

This supply rail is intended for going outside the ECU and therefore is protected against shorts to external chassis ground by a current-limit. The supply rail can be shorted externally within the specified short circuit voltages, VSOUT1_{SH}. If the output can be shorted to voltages outside the specified short circuit voltage range, additional external protection is required.

The VSOUT1 regulator is disabled by default on start-up. After the NRES pin release, the MCU can enable the VSOUT1 regulator through a SPI command by setting bit D0 in the SENS_CTRL register. After this SPI command, the soft-start circuit on this regulator is initiated, which is typically from 1 ms to 2 ms. This output may require a larger output capacitor to ensure that during load transients the output does NOT drop below the required regulation specifications. Regardless of tracking or non-tracking mode, the VSFB1 pin is ramped to the desired value after completion of the soft start.

The internal MOSFET is protected from excess power dissipation with a current-limit circuit and junction-temperature protection. In case of an overtemperature condition in the VSOUT1 pin, only the VSOUT1 regulator is switched off by clearing bit 0 in the SENS_CTRL register. To re-enable the VSOUT1 pin, first bit 2 in the SAFETY_STAT 1 register must be cleared on read-out, and afterwards bit 0 in the SENS_CTRL register must be set again.

The VSOUT1 pin voltage can be observed by the ADC input of the MCU through the DIAG_OUT pin (see [Section 5.4.9](#)), which allows the detection of a short to any other supply prior to enabling the VSOUT1 LDO.

NOTE

The VSOUT1_EN bit is in the SENS_CTRL register which is only reinitialized by a power-on reset (NPOR) event and not a transition through the RESET state. If the VSOUT1_EN bit was previously set to 1, it remains set to 1 and the VSOUT1 regulator remains enabled after events that cause a transition to the RESET state. In a fault case that would cause an undervoltage or overvoltage on the VSOUT1 pin, when a BIST runs automatically on the transition from the RESET to the DIAGNOSTIC state, the VSOUT1_UV or VSOUT1_OV condition during the BIST run would cause the device to go to the SAFE state because of the detected ABIST_ERR.

5.3.6 Charge Pump

The charge pump is used to generate an overdrive voltage from the VBATP supply that is used for driving the gates of the internal NMOS FETs in the VDDx and VSOUT1 supply rails. The charge pump is a hysteretic architecture, when the VCP voltage is high enough, the CP_OV bit sets and the charge pump stops pumping until the VCP voltage drops below the threshold, the CP_OV bit clears and the charge pump starts pumping again. The charge pump overdrive is provided internally to the device through the linear regulators, VCP12 and VCP17. Furthermore, this overdrive voltage can drive the gate of an external NMOS FET acting as reverse-battery protection. Such reverse-battery protection allows for lower battery voltage operation compared to a traditional reverse battery-blocking diode. When using the charge pump (VCP) to drive the gate of an NMOS for reverse battery protection, a series resistance of about 10 kΩ must be connected between the VCP pin and the gate of the NMOS FET (see [Section 5.2](#)). This series resistance is required to limit any current out of the VCP pin when the gate of the NMOS FET is driven to a negative voltage, because the absolute maximum rating of the VCP pin is limited to –0.3 V because of a parasitic reverse diode to the substrate (ground).

The charge pump requires two external capacitors, one pumping capacitor (C_{pump}) and one storage capacitor (C_{store}). To have sufficient overdrive voltage out of the charge pump even at low battery voltage, the external load current on the VCP pin must be less than 100 μA.

5.3.7 Wake-Up

The TPS65381A-Q1 device has two wake-up pins: IGN and CANWU. Both pins have a wake-up threshold level from 2 V to 3 V, and a hysteresis from 50 mV to 200 mV.

The IGN wake-up pin is level-sensitive and is deglitched with the IGN_deg deglitch (filter) time. The TPS65381A-Q1 device provides a power-latch function (POST_RUN) for this IGN pin, allowing the MCU to decide when to power down the TPS65381A-Q1 device through SPI command. For this, the MCU must set the IGN power-latch bit 4 (IGN_PWRL) in the SPI SAFETY_FUNC_CFG register, and read the unlatched status of the deglitched (filtered) IGN pin on the SPI register, DEV_STAT, bit 0 (IGN). To enter the STANDBY state, the MCU must clear the IGN_PWRL bit. For this, the TPS65381A-Q1 device must be in the DIAGNOSTIC state because this SPI register is only writable in the DIAGNOSTIC state. The IGN_PWRL bit is also cleared after a detected CANWU wake-up event. Furthermore, the TPS65381A-Q1 device provides an optional transition to the RESET state after a detected IGN wake-up during POST_RUN (see [Figure 5-2](#)).

The CANWU pin is level sensitive and is deglitched with CANWU_deg (filter) time. The deglitched (filtered) CANWU wake-up signal is latched, into CANWU_L, allowing the MCU to decide when to power down the TPS65381A-Q1 device through the WR_CAN_STBY SPI command.

NOTE

The WR_CAN_STBY command should not be written to the device while the CANWU pin or IGN pin is still high. The device starts to transition to the STANDBY state and immediately transitions to the RESET state because of the wake-up request received on the CANWU or IGN pin. The registers are reinitialization according to post LBIST (because of a RESET transition) or according to NPOR (because of a STANDBY transition).

Both the IGN and CANWU pins are high voltage pins. If the pins are connected to lines with transients, the application should provide proper filtering and protection to ensure the pins stay within the specified voltage range.

NOTE

If the application does not require wake up from IGN (ignition or KL15) or wake up from CANWU (a CAN or other transceiver), but the device should wake up any time power is supplied, one method is to connect the IGN pin to the VBATP pin (and VBAT_SAFING) through a 10-k Ω or greater series resistor. When the VBATP supply is turned on, the IGN pin also goes high and allows the device to wake up (power up) as soon as the voltage levels allow the release of NPOR circuits for the VBATP and VBAT_SAFING pins, and the IGN pin is high.

5.3.8 Reset Extension

During a power-up event, the TPS65381A-Q1 device releases the reset to the external MCU through the NRES pin with a certain delay time (reset extension time) after the VDD3/5 and VDD1 pins have crossed the respective undervoltage thresholds.

This reset extension time is externally configurable with a resistor between the RESEXT pin and ground. When shorting the RESEXT pin to ground, the minimum reset extension time is typically 1.4 ms. For a 22-k Ω external resistor, the typical reset extension time is 4.5 ms.

5.4 Device Functional Modes

5.4.1 Power-Up and Power-Down Behavior

Figure 5-1 shows the power-up and power-down behavior.

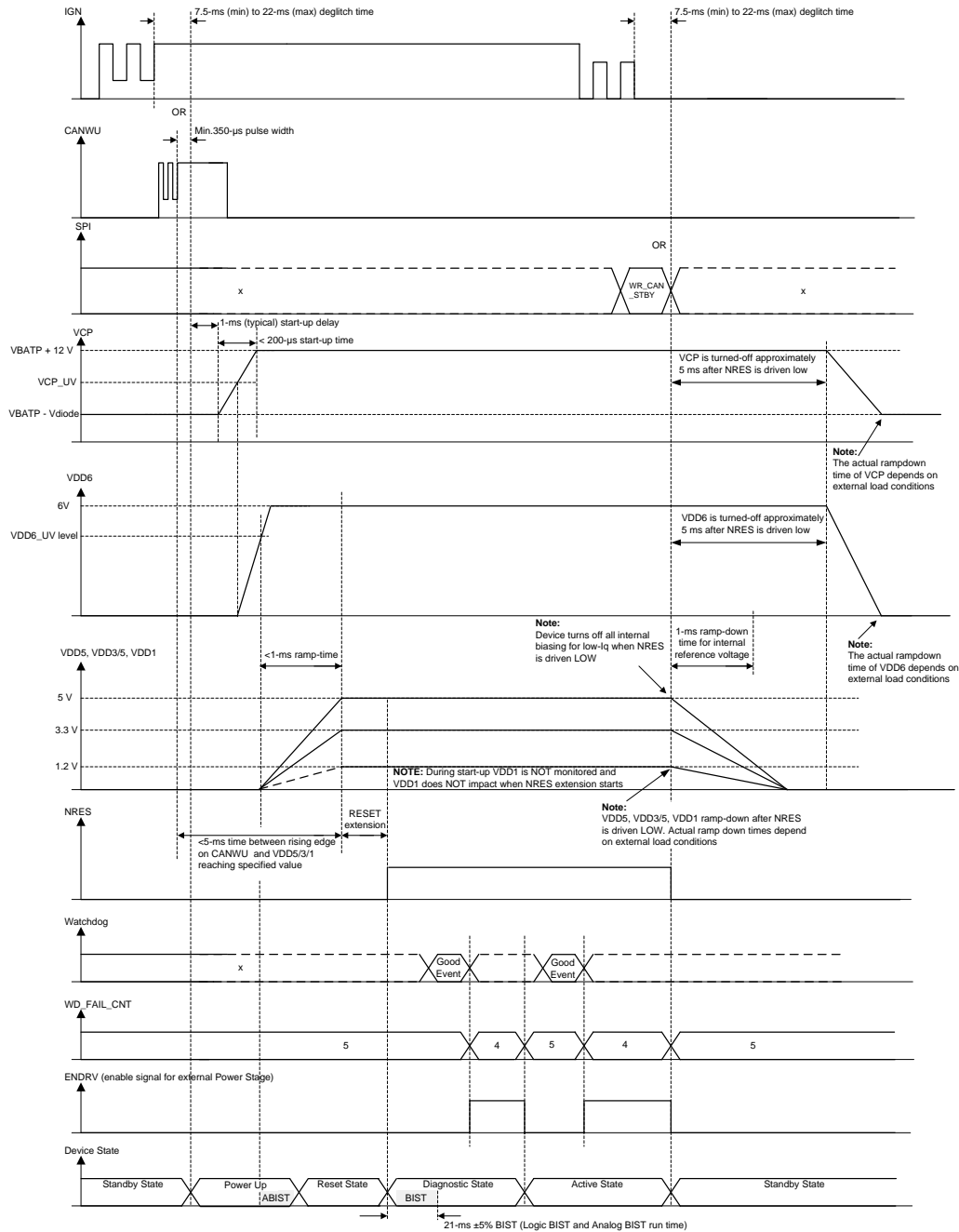

- (1) During a power-up event, the analog BIST (ABIST) begins automatically after the VDD6 rail ramps above the UV threshold. If the ABIST fails, the device transitions to the SAFE state.
- (2) The device may not be able to respond to MCU SPI communication during a BIST, so if the MCU boots faster than the BIST, it should wait until the BIST is complete to use SPI communication. If the ABIST, LBIST, or both fail, the device transitions to the SAFE state.
- (3) The level of the ENDRV pin depends on the watchdog failure counter, WD_FAIL_CNT[2:0], the ENABLE_DRV bit, and the signals shown in Figure 5-14. The MCU should only set the ENABLE_DRV bit when the WD_FAIL_CNT[2:0] counter is below 5.

Figure 5-1. Power-Up and Power-Down Behavior

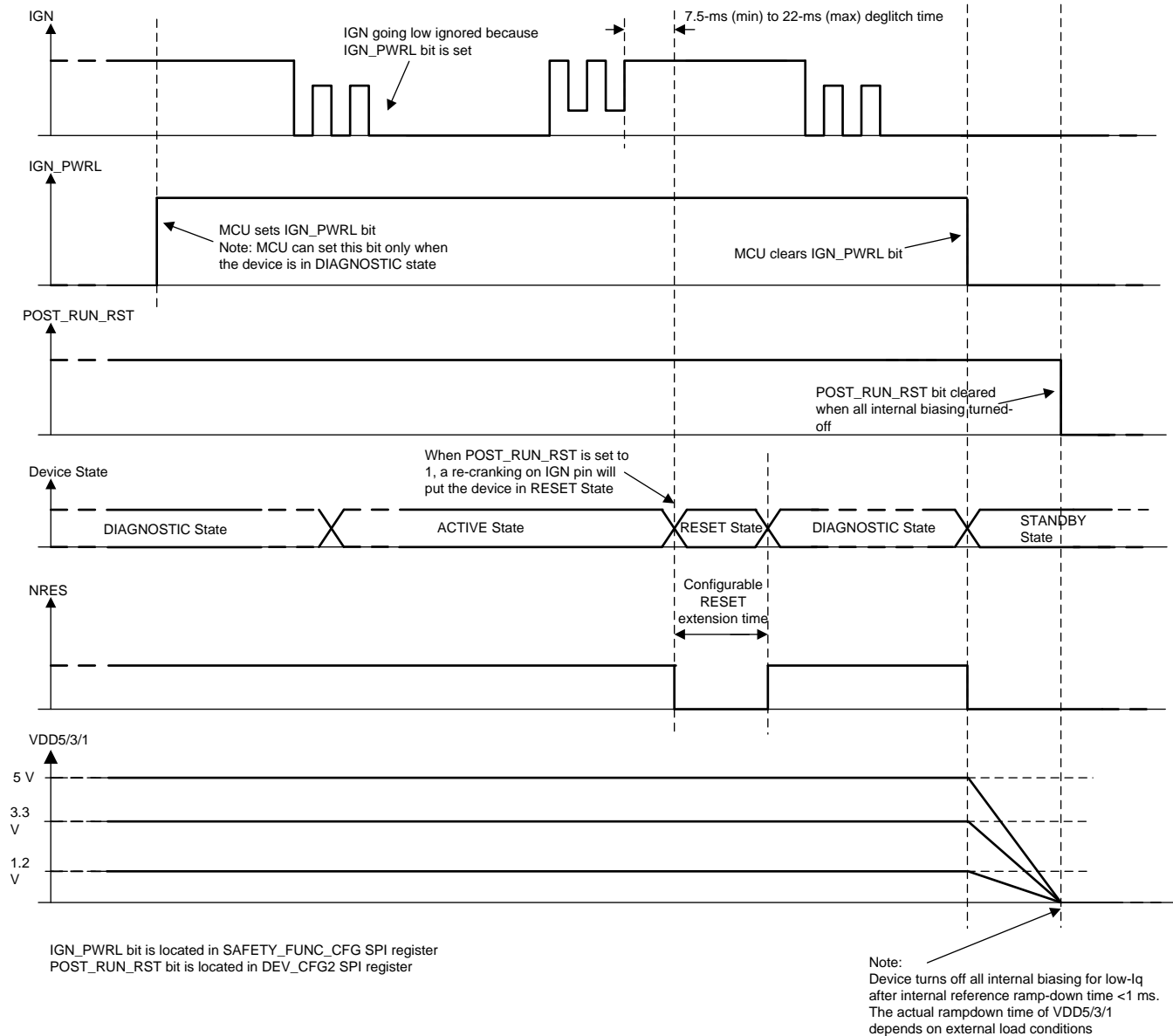

- (1) Under slow VBAT ramp-down and when the VDD3/5 rail is configured as a 5-V rail, the NRES output can be pulled low when VBAT is at approximately 6.3 V. This occurs because of an undervoltage transient on VDD3/5 rail.
- (2) Under slow VBAT ramp-up and when the VDD3/5 rail is configured as a 5-V rail, the NRES output can be pulled low when VBAT is at approximately 6.6 V. This occurs because of an undervoltage transient on VDD3/5 rail.
- (3) Under similar conditions, undervoltage transients are observed on VDD5 and VSOUT1 rails.

Figure 5-2. IGN Power Latch and POST-RUN Reset

5.4.2 Safety Functions and Diagnostics Overview

The TPS65381A-Q1 device is intended for use in automotive and industrial safety-relevant applications. The following list of monitoring and protection blocks are those that improve the diagnostic coverage and decrease the undetected fault rate:

- Voltage monitor (VMON)
- Analog built-in self-test (ABIST) diagnostics for safety analog blocks
- Logic built-in self-test (LBIST) for safety controller functions
- Loss-of-clock monitor (LCMON)
- Junction temperature monitoring for all power supplies with internal FET
- Current-limit for all power supplies
- Analog MUX (AMUX) for externally monitored diagnostics and debug
- Digital MUX (DMUX) for externally monitored diagnostics and debug
- Watchdog configurable for trigger mode (open and close window) or question and answer mode
- MCU error signal monitor (ESM) for monitoring the error output from functional safety architecture MCUs
- Controlled and protected enable output (ENDRV) for external power stages or peripheral wakeup
- Device configuration register CRC protection
- SPI command decoder with parity check
- SPI data output feedback check
- Reset circuit for initializing external MCU
- EEPROM analog trim content CRC protection
- Device state controller with SAFE state in case of detected error event

5.4.3 Voltage Monitor (VMON)

The VBAT supply voltage, all regulator outputs, and internally generated voltages are supervised by a voltage monitor module (VMON). An undervoltage or overvoltage condition is indicated by the corresponding VMON register status flag bits:

- VMON flag bit cleared to 0 when power supply is within specification
- VMON flag bit set to 1 when power supply is outside tolerance band

The monitoring occurs by undervoltage and overvoltage comparators. The reference voltage (BANDGAP_REF2) for the VMON module is independent of the system reference voltage (BANDGAP_REF1) used by the regulators. A glitch-filtering function ensures reliable monitoring without false setting of the VMON status flag bits. The complete VMON block is supplied by a separate supply pin, VBAT_SAFING.

The VMON comparator diagnostics are covered by the ABIST executed during device startup and power up or activated with the SPI command by the external MCU SPI request when the device is in the DIAGNOSTIC or ACTIVE state. Each monitored voltage rail is emulated for undervoltage and overvoltage conditions on the corresponding comparator inputs, therefore forcing the corresponding comparator to toggle multiple times (in a toggling pattern observed and checked by the ABIST controller). The monitored voltage rails themselves are not affected during this self-test, so no real undervoltage or overvoltage event occurs on any of these rails because of this self-test.

[Table 5-1](#) lists an overview of the performed voltage monitoring. As listed in this table, an overvoltage protection is implemented for some of the internal supply rails.

Table 5-1. Voltage Monitoring Overview⁽¹⁾

VOLTAGE RAIL	OUTPUT VOLTAGE	CREATED FROM REFERENCE	MONITORING DETECTION THRESHOLDS		MONITORED AGAINST REFERENCE	MONITORED PIN	OV PROTECTION LEVEL	OV PROTECTION REFERENCE	IMPACT ON DEVICE BEHAVIOR	
			UV	OV					UV	OV
SUPPLY INPUT										
VBAT	N/A	N/A	4.2 to 4.5 V	34.7 to 36.7 V	VMON_BG	VBATP	N/A	N/A	SPI flag VMON_STAT_1 D6 STANDBY state NRES = 0, ENDRV = 0	SPI flag VMON_STAT_1 D7 RESET state (when MASK_VBATP_OV = 0)
SUPPLY OUTPUTS										
VDD6	6 V ± 10%	MAIN_BG	5.2 to 5.4 V	7.8 to 8.2 V	VMON_BG	VDD6	N/A	N/A	SPI flag VMON_STAT_2 D6	SPI flag VMON_STAT_2 D7
VDD5	5 V ± 2%	MAIN_BG	4.5 to 4.85 V	5.2 to 5.45 V	VMON_BG	VDD5	N/A	N/A	SPI flag VMON_STAT_2 D4	SPI flag VMON_STAT_2 D5 ENDRV = 0
VDD3/5 (5 V)	5 V ± 2%	MAIN_BG	4.5 to 4.85 V	5.2 to 5.5 V	VMON_BG	VDD3/5	N/A	N/A	SPI flag VMON_STAT_2 D2 RESET state NRES = 0, ENDRV = 0	SPI flag VMON_STAT_2 D3 ENDRV = 0
VDD3/5 (3.3 V)	3.3 V ± 2%		3 to 3.17 V	3.43 to 3.6 V						
VDD1	0.8 V to 3.3 V –1% to +2% VDD1_SENSE = 800 mV –1% to +2%	MAIN_BG	0.94 to 0.98 × VDD1	1.03 to 1.06 × VDD1	VMON_BG	VDD1_SENSE	N/A	N/A	SPI flag VMON_STAT_2 D0 RESET state NRES = 0, ENDRV = 0 (when NMASK_VDD1_UV_OV=1)	SPI flag VMON_STAT_2 D1 ENDRV = 0 (when NMASK_VDD1_UV_OV=1)
VSOUT1 (non-tracking)	3.3 V to 9.5 V ± 2% VDSFB1 = 2.5 V ± 2%	MAIN_BG	0.88 to 0.94 × VSOUT1	1.06 to 1.12 × VSOUT1	MAIN_BG	VSFB1	N/A	N/A	SAFETY_STAT1 D5	SPI flag SAFETY_STAT1 D4
VSOUT1 (tracking)	3.3 V to 9.5 V ± 2% VDSFB1 = VTRACK1 ± 20 mV	VTRACK1			VTRACK1	VSFB1	N/A	N/A		
INTERNAL SUPPLIES										
VCP17	17 V (typ)	MAIN_BG	N/A	27 V (typ)	VMON_BG	N/A	27 V (typ)	VMON_BG	N/A	SPI flag VMON_STAT_1 D5 → STANDBY state NRES = 0, ENDRV = 0
VCP12	12 V (typ)	MAIN_BG	7.43 V (typ)	14.2 V (typ)	VMON_BG	N/A	14.2 V (typ)	VMON_BG	SPI flag VMON_STAT_1 D3	SPI flag VMON_STAT_1 D4 VDD5, VDD3/5 and VDD1 not operational → STANDBY state NRES = 0, ENDRV = 0
AVDD	6.9 V (typ)	Internal LV Zener	3.6 V (typ)	N/A	Independent local band gap	N/A	NA	Internal MV Zener	NPOR → STANDBY state NRES = 0, ENDRV = 0	No Change
AVDD_VMON	6.9 V (typ)	Internal LV Zener	3.56 V (typ)	N/A	Independent local band gap	Indirectly monitoring VBAT_SAFING	< 10.48 V	Internal MV Zener	SPI flag VMON_STAT_1 D2 → NPOR → STANDBY state NRES = 0, ENDRV = 0	SPI flag VMON_STAT_1 D2 → NPOR → STANDBY state NRES = 0, ENDRV = 0
DVDD	3 V (typ)	MAIN_BG	2.472 V (typ)	3.501 V (typ)	VMON_BG	N/A	N/A	N/A	NPOR → STANDBY state NRES = 0, ENDRV = 0	NPOR → STANDBY state NRES = 0, ENDRV = 0
INTERNAL REFERENCES										
MAIN_BG	2.5 V ± 2%	MAIN_BG	2.364 V (typ)	2.617 V (typ)	VMON_BG	N/A	N/A	N/A	STANDBY state NRES = 0, ENDRV = 0	STANDBY state NRES = 0, ENDRV = 0
VMON_BG	2.5 V ± 2%	VMON_BG	2.364 V (typ)	2.617 V (typ)	MAIN_BG	N/A	N/A	N/A	STANDBY state NRES = 0, ENDRV = 0	STANDBY state NRES = 0, ENDRV = 0

(1) N/A = Not applicable

5.4.4 TPS65381A-Q1 Internal Error Signals

Table 5-2 lists a useful overview of the TPS65381A-Q1 device internal error signals and the impact of the signals on the device behavior.

Table 5-2. Internal Error Signals

DMUX POS. NO.	SIGNAL NAME	DESCRIPTION	DETECTIVE CONDITION (THRESHOLD LEVEL)					DEGLITCH TIME TO SET FLAG (µs)				DEVICE STATE WHEN FLAG IS SET		
			MIN	TYP	MAX	UNIT	ELEC. CHAR. NO.	MIN	TYP	MAX	ELEC. CHAR. NO.	NRES	ENDRV	DEVICE STATE
D1.2	NAVDD_UV	AVDD undervoltage comparator output (inverted)		3.6		V		15		30		LOW	LOW	STANDBY
D1.3	BG_ERR1	VMON or main band gap is OFF (set to 1 when VMON band gap > main band gap)		Main band gap = 2.364 (VMON band gap = 2.477)		V		15		30		LOW	LOW	STANDBY
D1.4	BG_ERR2	VMON or main band gap is OFF (set to 1 when VMON band gap < main band gap)		Main band gap = 2.617 (VMON band gap = 2.477)		V		15		30		LOW	LOW	STANDBY
D1.5	NVCP12_UV	VCP12 charge pump undervoltage comparator (inverted)		7.43		V		15		30		Not changed	Not changed	Not changed
D1.6	VCP12_OV	VCP12 charge-pump overvoltage comparator		14.2		V		15		30		LOW	LOW	STANDBY
D1.7	VCP17_OV	VCP17 charge-pump overvoltage comparator		21		V		15		30		LOW	LOW	STANDBY
D1.8	NVDD6_UV	VDD6 undervoltage comparator (inverted)	5.2		5.4	V	6.22	10		40	6.18	Not changed	Not changed	Not changed
D1.9	VDD6_OV	VDD6 overvoltage comparator	7.8		8.2	V	6.23	10		40	6.18	Not changed	Not changed	Not changed
D1.10	NVDD5_UV	VDD5 undervoltage comparator (inverted)	4.5		4.85	V	6.8	10		40	6.18	Not changed	Not changed	Not changed
D1.11	VDD5_OV	VDD5 overvoltage comparator	5.2		5.45	V	6.10	10		40	6.18	Not changed	LOW	Not changed
D1.12	NVDD3/5_UV	VDD3/5 undervoltage comparator; 3.3-V setting (inverted)	3		3.17	V	6.12	10		40	6.18	LOW	LOW	RESET
		VDD3/5 undervoltage comparator; 5-V setting (inverted)	4.5		4.85									
D1.13	VDD3/5_OV	VDD3/5 overvoltage comparator; 3.3-V setting	3.43		3.6	V	6.14	10		40	6.18	Not changed	LOW	Not changed
		VDD3/5 overvoltage comparator; 5-V setting	5.2		5.5									
D1.14	NVDD1_UV	VDD1 undervoltage comparator (inverted)	0.94		0.98	VDD1	6.16	10		40	6.18	Not changed when NMASK_VDD1_UV_OV = 0 (default config) When NMASK_VDD1_UV_OV = 1: NRES = LOW	Not changed when NMASK_VDD1_UV_OV = 0 (default config) When NMASK_VDD1_UV_OV = 1: ENDRV = LOW	Not changed when NMASK_VDD1_UV_OV = 0 (default config) When NMASK_VDD1_UV_OV = 1: RESET
D1.15	VDD1_OV	VDD1 overvoltage comparator	1.03		1.06	VDD1	6.17	10		40	6.18	Not changed	Not changed (default config) When MASK_VDD1_UV_OV = 1: ENDRV = LOW	Not changed

Table 5-2. Internal Error Signals (continued)

DETECTIVE CONDITION (THRESHOLD LEVEL)								DEGLITCH TIME TO SET FLAG (µs)				DEVICE STATE WHEN FLAG IS SET			
DMUX POS. NO.	SIGNAL NAME	DESCRIPTION	MIN	TYP	MAX	UNIT	ELEC. CHAR. NO.	MIN	TYP	MAX	ELEC. CHAR. NO.	NRES	ENDRV	DEVICE STATE	
D1.16	LOCLK	Loss-of-system-clock comparator	0.742		2.64	MHz		0.379		1.346		LOW	LOW	STANDBY	
D3.4	CP_OV	Charge-pump overvoltage comparator		VBAT + 12		V		N/A	N/A	N/A		Not changed	Not changed	Not changed	
D3.5	NCP_UV	Charge-pump undervoltage comparator (inverted)		VBAT + 6		V		N/A	N/A	N/A		Not changed	Not changed	Not changed	
D3.8	CP_DIFF3V	Indicates VCP-VBATP > 3 V		VBAT + 3		V		N/A	N/A	N/A		Not changed	Not changed	Not changed	
D3.10	NVBAT_UV	VBAT undervoltage comparator (inverted)	4.2		4.5	V	6.1		200		6.7	LOW	LOW	STANDBY	
D3.11	VBATP_OV	VBAT overvoltage comparator	34.7		36.7	V	6.5		200		6.7	LOW (default config) When MASK_VBATP_OV = 1: NRES unchanged	LOW (default config) When MASK_VBATP_OV = 1: ENDRV unchanged	RESET (default config) When MASK_VBATP_OV = 1: device state unchanged	
D3.12	VDD5_OT	VDD5 overtemperature	175		210	°C	3.13	45		64		LOW	LOW	Device state depends on NMASK_VDD5_OT bit setting: NMASK_VDD5_OT = 0 : no impact to device state NMASK_VDD5_OT = 1 : VDD5 disabled → RESET	
D3.13	VDD3/5_OT	VDD3/5 overtemperature	175		210	°C	2.13	45		64		LOW	LOW	Device state depends on NMASK_VDD3/5_OT bit setting: NMASK_VDD3/5_OT = 0 : VDD3/5 disabled → VDD3/5 UV event → RESET NMASK_VDD3/5_OT = 1 : STANDBY	
D3.14	VSOUT1_OT	VSOUT1 overtemperature	175		210	°C	5.13	45		64		Not changed	Not changed	Not changed	
D3.15	VDD5_CL	VDD5 current-limit ⁽¹⁾	350		650	mA	2.14	15		30		Not changed	Not changed	Not changed	
D3.16	VDD3/5_CL	VDD3/5 current-limit	350		650	mA	3.14	15		30		Not changed	Not changed	Not changed	
D4.2	VSOUT1_CL	VSOUT1 current-limit	100		500	mA	5.19	15		30		Not changed	Not changed	Not changed	
D4.3	NVSOUT1_UV	VSOUT1 undervoltage comparator (inverted)	0.88		0.94	VSOUT1	6.19	10		40	6.21	Not changed	Not changed	Not changed	
D4.4	VSOUT1_OV	VSOUT1 overvoltage comparator	1.06		1.12	VSOUT1	6.20	10		40	6.21	Not changed	Not changed	Not changed	
D4.5	NDVDD_UV	DVDD undervoltage comparator (inverted)		2.472		V			0			LOW	LOW	STANDBY	
D4.6	DVDD_OV	DVDD overvoltage comparator		3.501		V			0			LOW	LOW	STANDBY	
D4.8	VS_TRK_MODE	VSOUT1 in track-mode indication		1.2		V	5.3a	N/A	N/A	N/A		Not changed	Not changed	Not changed	
D4.9	VMON_TRIM_ERR	VMON trim error	Set when bit-flip in VMON trim registers is detected						5		10		LOW	LOW	STANDBY

(1) VDD5_CL DMUX output is valid only when VDD5_EN bit in SENS_CTRL register is set to 1. When VDD5_EN is cleared to 0, this VDD5_CL will be high.

5.4.5 Loss-of-Clock Monitor (LCMON)

The LCMON detects internal oscillator failures including:

- Oscillator clock stuck high or stuck low
- Reduced clock frequency

The LCMON is enabled during a power-up event after the power-on reset (NPOR) is released. The clock monitor remains active during device normal operation (STANDBY, RESET, DIAGNOSTIC, ACTIVE, and SAFE states). In case of a clock failure:

- The device transitions to the STANDBY state.
- All regulators are disabled.
- The digital core is reinitialized.
- The reset to the external MCU is asserted low.
- The failure condition is indicated by the LOCLK bit in the SAFETY_STAT_4 register.

The LCMON has a self-test structure that is activated and monitored by an analog BIST (ABIST). The external MCU can recheck the LCMON any time when the device is in the DIAGNOSTIC state or ACTIVE state. The enabled diagnostics emulate a clock failure that causes the clock-monitor output to toggle. The clock-monitor toggling pattern is checked by the ABIST, while the external MCU can check that the loss-of-clock status bit is being set during active test. During this self-test, the actual oscillator frequency (4 MHz) is not changed because of this self-test.

5.4.6 Analog Built-In Self-Test (ABIST)

The ABIST is the controller and monitor circuit for performing self-checking diagnostics on critical analog functions:

- VMON undervoltage and overvoltage comparators
- Clock monitor (LCMON)
- EEPROM analog-trim content check (CRC protection)

During the self-test on the VMON undervoltage and overvoltage comparators, the monitored voltage rails are left unchanged, so no real undervoltage or overvoltage event occurs on any of these rails because of these self-tests. Furthermore, also during the self-check on the clock monitor, the actual oscillator frequency (4 MHz) is not changed because of this self-test.

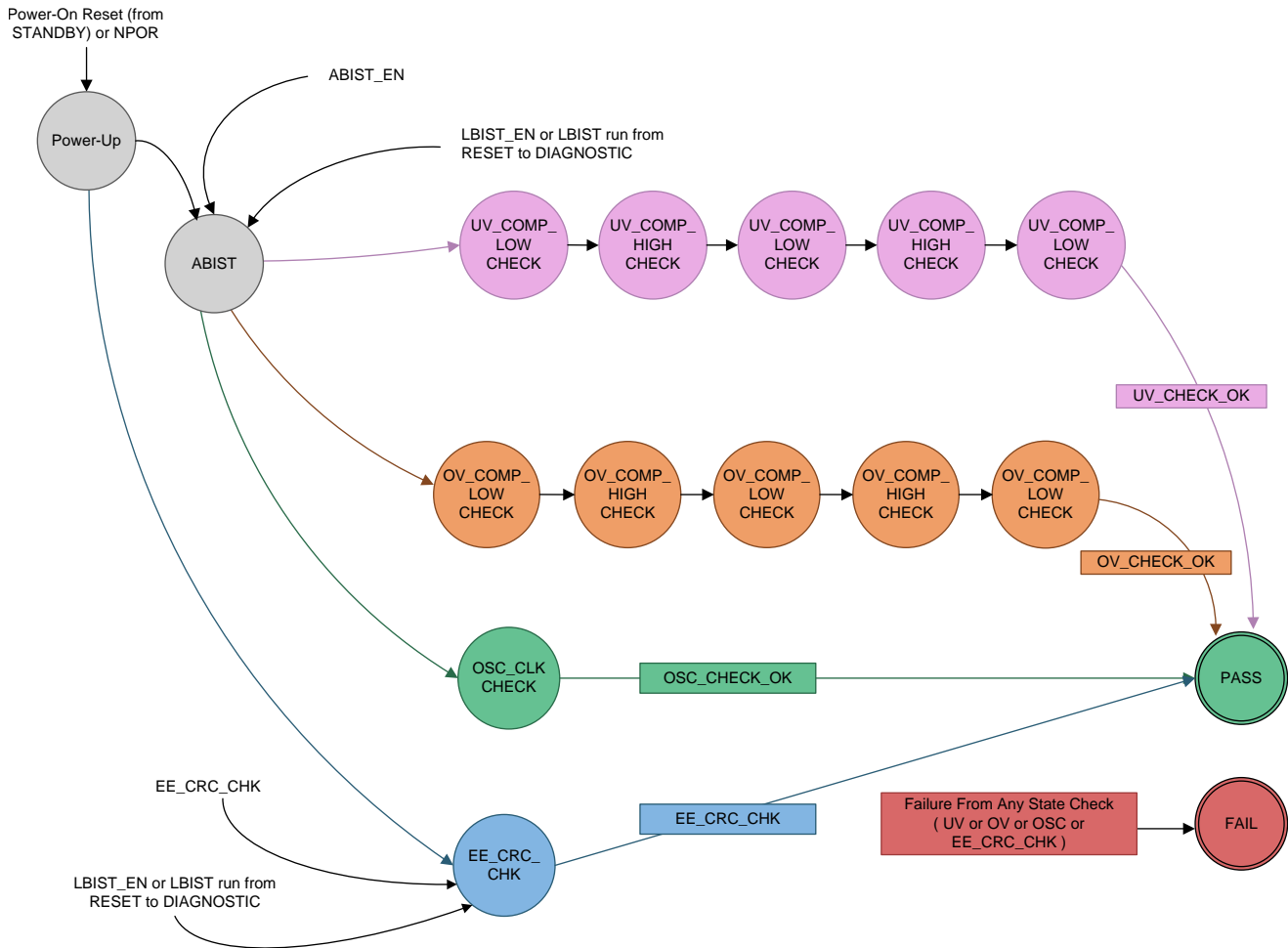

(1) For impact to the device state if any ABIST function has a FAIL, see [Section 5.4.19](#).

Figure 5-3. Analog BIST Run States

The ABIST is activated with every device power-up event or any transition to the RESET state. The ABIST can also be run by the external MCU by setting the ABIST_EN bit in the SAFETY_BIST_CTRL register. During an ABIST run, the device cannot monitor the state of the regulated supplies, and the ENDRV pin is pulled low. The ABIST run time is approximately 300 μs. The ABIST can be performed in the ACTIVE state on an MCU request, depending on system safety requirements (such as a system-fault response time), ENDRV pin will be low during ABIST run.

A running ABIST is indicated in the ABIST_RUN bit (bit D0) in the SAFETY_STAT_3 register. This bit is set to 1 during the ABIST run and is cleared to 0 when the ABIST is complete. In case of an ABIST failure while in the DIAGNOSTIC state, including power-up event, the device enters the SAFE state without asserting a reset to the external MCU and the ABIST_ERR status flag remains latched in the digital core until a successful ABIST run. This allows the external MCU to detect the ABIST failure by reading the ABIST_ERR bits in the SAFETY_STAT_3 register. In case of an ABIST failure while in the ACTIVE state, the device sets the ABIST_ERR status flag, but no state transition occurs.

5.4.7 Logic Built-In Self-Test (LBIST)

The logic BIST (LBIST) tests the digital-core safety functions. The LBIST has these characteristics:

- An application-controllable logic BIST engine, which applies test vectors to the digital core.
- The LBIST engine provides stuck-at fault test coverage to logic blocks under test.
- The LBIST run time is typically 4.2 ms ($\pm 5\%$). After the LBIST, a 16-ms (typical) wait period occurs to fill the digital filters covered by the LBIST. During this time, the ABIST runs. The total BIST time is approximately 21 ms. The SPI registers may be unavailable during a BIST, so no SPI reads or writes should be made while the BIST is running.
- The LBIST engine has a time-out counter as a fail-safe feature.

The BIST (LBIST with ABIST) is activated and run in the DIAGNOSTIC state with any transition out of the RESET state during power-up events. The BIST is also activated with any other transition out of the RESET state unless the AUTO_BIST_DIS bit in the SAFETY_BIST_CTRL register is set.

The MCU can run the LBIST (BIST) by setting the LBIST_EN bit in the SAFETY_BIST_CTRL register.

NOTE

In the ACTIVE state the following considerations must be considered if a manual run of the LBIST is initiated by setting the LBIST_EN bit to 1. The LBIST should only be run in the ACTIVE state if the system-safety timing requirements can allow the total 21-ms BIST time and ENDRV being low for the 21-ms time.

NOTE

In the ACTIVE or DIAGNOSTIC or SAFE state the following considerations must be considered if a manual run of the LBIST is initiated by setting the LBIST_EN bit to 1. After the LBIST is complete the WD_FAIL_CNT[2:0] counter is re-initialized to 5. The MCU should resynchronize to the TPS65381A-Q1 watchdog by writing to the WD_WIN1_CFG or WD_WIN2_CFG register or by immediately causing a bad event. Both of these resynchronization options start a new watchdog sequence and increment the WD_FAIL_CNT[2:0] counter. If the WD_RST_EN bit is set to 1 (enabled), the watchdog service routine in the MCU must ensure good events are sent to the watchdog to start decrementing the WD_FAIL_CNT[2:0] counter before it reaches 7 +1 which cause a transition to the RESET state. After the LBIST is complete some of the registers are reinitialized. If the these configuration registers change from the initialized values, these registers must be reconfigured to the required setting for the application.

NOTE

In the DIAGNOSTIC state the following considerations must be taken into account if a manual run of the LBIST is initiated by setting the LBIST_EN bit to 1. Setting the LBIST_EN bit to 1 clears the DIAG_EXIT_MASK bit to 0. If the DIAG_EXIT_MASK bit is being used to hold the device in the DIAGNOSTIC state for software debug, it must be set again to 1 after LBIST completion to stay in the DIAGNOSTIC state. The DIAGNOSTIC state time-out counter stops only during the running of the LBIST. After the LBIST is complete, the time-out counter continues from the last value. For a transition from the DIAGNOSTIC state to the ACTIVE state, the DIAG_EXIT bit must be set to 1.

During the BIST run, the device cannot monitor the state of regulated supplies and cannot respond to any SPI command, and therefore cannot monitor the state of the MCU through the watchdog timer. During the BIST run, the ENDRV pin is pulled low and the watchdog fail counter reinitializes to 5. After the BIST is complete, the following functions and registers reinitialize:

- DEV_STAT
- SAFETY_STAT_2
- SAFETY_STAT_4
- SAFETY_STAT_5 (but FSM[2:0] will immediately update to reflect the current device state)
- WD_TOKEN_VALUE
- WD_STATUS
- SAFETY_CHECK_CTRL
- DIAG_CFG_CTRL
- DIAG_MUX_SEL

A running LBIST is indicated in the LBIST_RUN bit (bit D1) in the SAFETY_STAT_3 register. This bit is set to 1 while the LBIST is running and is cleared to 0 when the LBIST is complete. After the LBIST run, completion of the whole BIST is confirmed by the MCU by reading 0 for both the LBIST_RUN and ABIST_RUN bits.

In case of an LBIST failure in the DIAGNOSTIC state, the device enters the SAFE state. The external MCU can detect the LBIST failure by reading the LBIST_ERR bit in the SAFETY_STAT_3 register. In case of an LBIST failure while in the ACTIVE state, the device sets the LBIST_ERR status flag, but no state transition occurs. Because the ABIST is run during the LBIST, the ABIST_ERR bit can also be monitored by the MCU.

5.4.8 Junction Temperature Monitoring and Current Limiting

Each LDO with an internal power FET has junction temperature monitoring with overtemperature protection (thermal shutdown). In case of an overtemperature condition, a regulated supply can re-enable only after the overtemperature condition is removed.

For the VSOUT1 regulator, the overtemperature condition disables the regulator and clears the enable bit (VSOUT1_EN), while all other regulators remain enabled. When the VSOUT1 overtemperature condition is gone, the external MCU must set the enable control bit again to re-enable the regulator.

The VDD3/5 and VDD6 regulators share an overtemperature protection circuit. A overtemperature event disables the VDD3/5 regulator. If the NMASK_VDD3/5_OT is set to 1 (default), the device transitions to the STANDBY state. If the NMASK_VDD3/5_OT bit is cleared to 0, the device transitions to the RESET state when the VDD3/5 output reaches the UV level for the VDD3/5 regulator. In both cases the NRES pin goes low and resets the external MCU and the ENDRV pin is low. TI recommends using the device with the NMASK_VDD3/5_OT bit set to 1.

For the VDD5 regulator, the overtemperature condition clears the VDD5_EN enable bit and transitions to the RESET state. NRES pin goes low and resets the MCU and the ENDRV pin is low. All other regulators remain enabled. When the VDD5 overtemperature condition is gone, the MCU must set the enable control bit again to re-enable the regulator.

The VDD6, VDD3/5, VDD5, and VSOUT1 regulators include a current-limit circuit for protection against excessive power consumption and thermal overstress.

Table 5-3 lists an overview of the overtemperature and overcurrent protections for the supply output rails.

Table 5-3. Overtemperature and Overcurrent Protection Overview

VOLTAGE RAIL	OVERTEMPERATURE PROTECTION		OVERCURRENT PROTECTION	
	THRESHOLD (°C)	IMPACT ON DEVICE BEHAVIOR	CURRENT-LIMIT	IMPACT ON DEVICE BEHAVIOR
VDD6	175 to 210 (shared with VDD6 and VDD3/5)	Sets VDD3/5_OT (in SAFETY_STAT_1) when NMASK_VDD3/5_OT = 1, STANDBY state when NMASK_VDD3/5_OT = 0, disables VDD3/5, RESET when VDD3/5 reaches UV level	1.5 to 2.5 A	None
VDD3/5			350 to 650 mA	Sets VDD3/5_ILIM (in SAFETY_STAT_1)
VDD5	175 to 210	Sets VDD5_OT (in SAFETY_STAT_1) when NMASK_VDD5_OT = 1, clears VDD5_EN (in SENS_CTRL) and VDD5 switched off, RESET state when NMASK_VDD5_OT = 0, overtemperature indicated in VDD5_OT	350 to 650 mA	Sets VDD5_ILIM (in SAFETY_STAT_1)
VDD1	None	N/A	None	N/A
VSOUT1	175 to 210	Sets VSOUT1_OT (in SAFETY_STAT_1) clears VSOUT1_EN (in SENS_CTRL) and VSOUT1 disabled	100 to 500 mA	DIAG_OUT through digital MUX for VSOUT1_CL

5.4.9 Diagnostic MUX and Diagnostic Output Pin (DIAG_OUT)

Analog and digital critical signals, which are not directly connected to the MCU, are switched by a multiplexer to the external DIAG_OUT pin. The programming of the multiplexer is done with the DIAG_MUX_SEL register. The digital signals are buffered to have sufficient drive capabilities.

This multiplexer facilitates external pin-interconnect tests by feeding back the input pin state or feeding back internal module self-test status or safety comparator outputs.

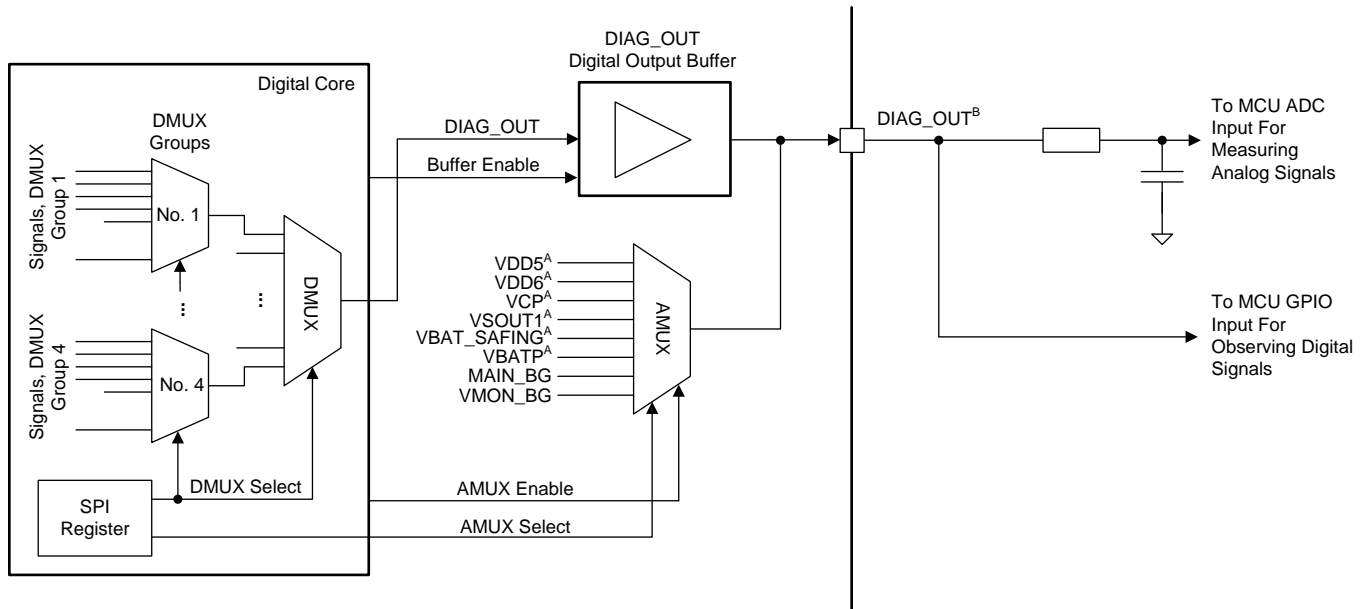

- A. These analog signals are multiplexed out with a divide ratio
- B. If the application must measure analog signals with an MCU ADC and monitor digital signals with an MCU GPIO, the application design must assure the GPIO input stage does not affect the ADC measurements. If isolating the MCU GPIO is not possible within the MCU, the application design must achieve the necessary isolation externally.

Figure 5-4. Diagnostic Output Pin, DIAG_OUT

In case the DIAG_OUT pin is connected to a mixed analog or digital input pin of the MCU, TI recommends configuring this MCU input pin and the DIAG_OUT pin simultaneously in accordance with the desired type of signal (analog or digital). The type of signal (analog or digital) on the DIAG_OUT pin can be configured with the MUX_CFG[1:0] bits in the DIAG_CFG_CTRL register. The DIAG_OUT multiplexer can be globally enabled and disabled with bit 7 in the DIAG_CFG_CTRL register. When disabled, the DIAG_OUT pin is in the high-ohmic state (tri-state).

NOTE

When enabling the DIAG_OUT MUX while using SPI communication, the SDO pin is not in the high impedance state while the NCS pin is high and the DIAG_OUT MUX is enabled. Software or hardware modification may be required in the application. For hardware modifications check the SDO threshold level and drive capability if resistors are used to adjust the voltage level of the SDO pin on the SPI bus or use a buffer gate with an enable and tri-state output such as the [SN74AHC1G125](#) to allow the downstream SDO signal to be in the high impedance state if required in the application while the NCS pin is high even if the DIAG_OUT MUX is enabled.

5.4.9.1 Analog MUX (AMUX)

Table 5-4 lists the selectable-analog internal signals on the DIAG_OUT pin. In the DIAG_CFG_CTRL register, the MUX_CFG[1:0] bits must be set to 10b for the analog MUX mode.

Table 5-4. Analog MUX Selection Table

SIGNAL NUMBER	VOLTAGE RAIL or SIGNAL NAME	DESCRIPTION	SUPPLY RANGE ⁽¹⁾	DIVIDE RATIO	DIVIDE RATIO ACCURACY ⁽²⁾		OUTPUT RESISTANCE (k Ω)		DIAG_MUX_SEL[7:0]
					MINIMUM	MAXIMUM	MINIMUM	MAXIMUM	
A.1	VDD5	Linear VDD5 regulator output	5.8 to 34 V	2	-2.25 %	0.75 %	20	50	0x01
A.2	VDD6	Switch mode preregulator	5.8 to 34 V	3	-3.75%	0.5 %	30	100	0x02
A.3	VCP	Charge pump	5.8 to 18V	13.5	-6.25 %	2.25 %	90	200	0x04
			5.8 to 34 V		-6.25%	4.75 %			
A.4	VSOUT1	Sensor supply voltage	5.8 to 34 V	4	-0.5 %	1.2 %	40	100	0x08
A.5	VBAT_SAFING	Battery (supply) input for monitoring (VMON) and BG2 functions	5.8 to 18 V	10	-5 %	0 %	125	200	0x10
			5.8 to 34 V		-5 %	5.5 %			
A.6	VBATP	Battery (supply), main power supply	5.8 to 18V	10	-5 %	0 %	125	200	0x20
			5.8 to 34 V		-5 %	5.5 %			
A.7	MAIN_BG	Regulators band-gap reference	5.8 to 34 V	1	NA		3	15	0x40
A.8	VMON_BG	Voltage-monitor band gap	5.8 to 34 V	1	NA		3	15	0x80

(1) The supply range is the input supply range for VBATP and VBAT_SAFING (VBATP = VBAT_SAFING).

(2) The given accuracies are without the DC load-current drawn from the DIAG_OUT pin. For overall accuracy calculation, the divide ratio accuracy and the drop voltage caused by $I_{\text{DIAG_OUT}} \times \text{output resistance}$ must be considered.

In case one of the AMUX signals after the divide ratio is at a voltage above the VDDIO voltage, a clamp becomes active to avoid any voltage level higher than the VDDIO voltage on the DIAG_OUT pin.

To achieve the fastest stabilization of the signal switched to the DIAG_OUT pin, following the AMUX switching order from A.1 up to A.8 is not recommended.

The recommendation is to switch the order from high-to-low voltage, starting with A.8. For example: A.8 – A.7 – A.1 – A.2 – A.3 – A.5 – A.6 – A.4.

NOTE

The sensor-supply output voltage (VSOUT1) is 0 V in this example. If the VSOUT1 voltage is higher, then the switching order described in the previous example must be changed.

NOTE

In the application, a series resistance of at least 100 k Ω is required on the input capacitor filter of the ADC input of the MCU.

5.4.9.2 Digital MUX (DMUX)

The following tables list the selectable digital internal signals on the DIAG_OUT pin. In the DIAG_CFG_CTRL register, the MUX_CFG[1:0] bits must be cleared to 01b for the digital MUX mode.

Most of these signals are internal error signals that influence the device state and behavior of the NRES pin and the ENDRV pin. See Table 5-2 for a more detailed table listing the internal error signals and their impact on the device behavior.

Table 5-5. Digital MUX Selection Table – Group 1

SIGNAL NUMBER	SIGNAL NAME	DESCRIPTION	CHANNEL GROUP DIAG_MUX_SEL [6:4]	CHANNEL NUMBER DIAG_MUX_SEL [3:0]
D1.1	RSV	Reserved, logic 0	000b	0000b
D1.2	NAVDD_UV	AVDD undervoltage comparator output (inverted)	000b	0001b
D1.3	BG_ERR1	VMON or main band gap is OFF	000b	0010b
D1.4	BG_ERR2	VMON or main band gap is OFF	000b	0011b
D1.5	NVCP12_UV	VCP12 charge-pump undervoltage comparator (inverted)	000b	0100b
D1.6	VCP12_OV	VCP12 charge-pump overvoltage comparator	000b	0101b
D1.7	VCP17_OV	VCP17 charge-pump overvoltage comparator	000b	0110b
D1.8	NVDD6_UV	VDD6 undervoltage comparator (inverted)	000b	0111b
D1.9	VDD6_OV	VDD6 overvoltage comparator	000b	1000b
D1.10	NVDD5_UV	VDD5 undervoltage comparator (inverted)	000b	1001b
D1.11	VDD5_OV	VDD5 overvoltage comparator	000b	1010b
D1.12	NVDD3/5_UV	VDD3/5 undervoltage comparator (inverted)	000b	1011b
D1.13	VDD3/5_OV	VDD3/5 overvoltage comparator	000b	1100b
D1.14	NVDD1_UV	VDD1 undervoltage comparator (inverted)	000b	1101b
D1.15	VDD1_OV	VDD1 overvoltage comparator	000b	1110b
D1.16	LOCLK	Loss-of-system-clock comparator	000b	1111b

Table 5-6. Digital MUX Selection Table – Group 2

SIGNAL NUMBER	SIGNAL NAME	DESCRIPTION	CHANNEL GROUP DIAG_MUX_SEL [6:4]	CHANNEL NUMBER DIAG_MUX_SEL [3:0]
D2.1	RSV	Reserved, logic 0	001b	0000b
D2.2	SYS_CLK	System clock source	001b	0001b
D2.3	DFT	Signal reserved for production test	001b	0010b
D2.4	WD_CLK	Watchdog clock reference (0.55-ms period time)	001b	0011b
D2.5	RST_EXT_CLK	Reset extension oscillator output	001b	0100b
D2.6	T_5US	5- μ s time reference	001b	0101b
D2.7	T_15US	15- μ s time reference	001b	0110b
D2.8	T_40US	40- μ s time reference	001b	0111b
D2.9	T_2MS	2-ms time reference	001b	1000b
D2.10	UC_ERROR/WDI	External MCU ERROR/WDI input pin	001b	1001b
D2.11	SPI_NCS	SPI chip-select input pin	001b	1010b
D2.12	SPI_SDI	SPI slave-data input pin	001b	1011b
D2.13	SPI_CLK	SPI clock input pin	001b	1100b
D2.14	SDO_RDBCK	SPI slave-data output-pin readback	001b	1101b
D2.15	UC_ERROR/WDI	Same signal as D2.10	001b	1110b
D2.16	NRES_EXT_IN	NRES pin readback (reset to external MCU)	001b	1111b

Table 5-7. Digital MUX Selection Table – Group 3

SIGNAL NUMBER	SIGNAL NAME	DESCRIPTION	CHANNEL GROUP DIAG_MUX_SEL [6:4]	CHANNEL NUMBER DIAG_MUX_SEL [3:0]
D3.1	RSV	Reserved, logic 0	010b	0000b
D3.2	DFT	Signal reserved for production test	010b	0001b
D3.3	DFT	Signal reserved for production test	010b	0010b
D3.4	CP_OV	Charge-pump overvoltage comparator	010b	0011b
D3.5	NCP_UV	Charge-pump undervoltage comparator (inverted)	010b	0100b
D3.6	CP_PH1	Charge-pump switching phase 1	010b	0101b
D3.7	CP_PH2	Charge-pump switching phase 2	010b	0110b
D3.8	CP_DIFF3V	Indicates VCP-VBATP > 3 V	010b	0111b
D3.9	DFT	Signal reserved for production test	010b	1000b
D3.10	NVBAT_UV	VBAT undervoltage comparator (inverted)	010b	1001b
D3.11	VBATP_OV	VBAT overvoltage comparator	010b	1010b
D3.12	VDD5_OT	VDD5 overtemperature	010b	1011b
D3.13	VDD3/5_OT	VDD3/5 overtemperature	010b	1100b
D3.14	VSOUT1_OT	VSOUT1 overtemperature	010b	1101b
D3.15	VDD5_CL	VDD5 current-limit	010b	1110b
D3.16	VDD3_CL	VDD3 current-limit	010b	1111b

Table 5-8. Digital MUX Selection Table – Group 4

SIGNAL NUMBER	SIGNAL NAME	DESCRIPTION	CHANNEL GROUP DIAG_MUX_SEL [6:4]	CHANNEL NUMBER DIAG_MUX_SEL [3:0]
D4.1	RSV	Reserved, logic 0	011b	0000b
D4.2	VSOUT1_CL	VSOUT1 current-limit	011b	0001b
D4.3	NVSOUT1_UV	VSOUT1 undervoltage comparator (inverted)	011b	0010b
D4.4	VSOUT1_OV	VSOUT1 overvoltage comparator	011b	0011b
D4.5	NDVDD_UV	DVDD undervoltage comparator (inverted)	011b	0100b
D4.6	DVDD_OV	DVDD overvoltage comparator	011b	0101b
D4.7	RSV	Reserved	011b	0110b
D4.8	VS_TRK_MODE	VSOUT1 in track-mode indication	011b	0111b
D4.9	VMON_TRIM_ERR	VMON trim error	011b	1000b
D4.10-16	RSV	Reserved	011b	1001b-1111b

Table 5-9. Digital MUX Selection Table – Group 5

SIGNAL NUMBER	SIGNAL NAME	DESCRIPTION	CHANNEL GROUP DIAG_MUX_SEL [6:4]	CHANNEL NUMBER DIAG_MUX_SEL [3:0]
D5.1	RSV	Reserved, logic 0	111b	0000b
D5.2	TI_TEST_MODE	TI production test mode indication	111b	0001b
D5.3-16	DFT	Signal reserved for production test	111b	0010b-1111b

A diagnostic check at the SDO digital-output pin is also possible in DMUX mode. For this diagnostic check, the following sequence is required:

1. The MUX_CFG[1:0] configuration must be set to 01b for DIGITAL MUX mode.
2. The SPI NCS must be kept HIGH.
3. The state of the SDO pin is controlled by the SPI_SDO bit (bit D6 in the DIAG_CFG_CTRL register).

During this SDO check at the SDO pin, the DIAG_OUT pin is kept low if no signal from the Digital MUX Selection table is selected.

5.4.9.3 Diagnostic MUX Output State (by MUX_OUT bit)

For a diagnostic interconnect check between the DIAG_OUT pin and the MCU analog-digital input pin, the state of the DIAG_OUT pin is controlled with the SPI bit, MUX_OUT, in the DIAG_CFG_CTRL register. To use this mode, the MUX_CFG[1:0] bits must be set to 00b in the DIAG_CFG_CTRL register.

5.4.9.4 MUX Interconnect Check

For performing a diagnostic interconnect check at the digital input pins (ERROR/WDI, NCS, SDI, and SCLK), the MUX_CFG[1:0] bits in the DIAG_CFG_CTRL register must be set to 11b. The INT_CON[2:0] bits in the DIAG_CFG_CTRL register can select which of these digital inputs to be multiplexed to the DIAG_OUT pin (see the description of DIAG_CFG_CTRL register in [Section 5.5.1](#)).

5.4.10 Watchdog Timer (WD)

The watchdog monitors the correct operation of the MCU. This watchdog requires specific triggers, or messages, from the MCU in specific time intervals to detect correct operation of the MCU. The MCU can control the logic level of the ENDRV pin with the ENABLE_DRV bit when the watchdog detects correct operation of the MCU. When the watchdog detects incorrect operation of the MCU, the device pulls the ENDRV pin low. This ENDRV pin can be used in the application as a control signal to deactivate the power output stages, for example a motor driver, in case of incorrect operation of the MCU. This function is consequently referred to as the watchdog-enabled function.

The watchdog has two different modes, which are defined as follows:

Trigger mode: In trigger mode, the MCU applies a trigger (pulse) on the ERROR/WDI pin to send the required watchdog event for trigger mode. The watchdog operates in trigger mode as the default mode when the device goes from the RESET state to the DIAGNOSTIC state. The MCU error signal monitor (ESM) should not be used when the watchdog operates in trigger mode.

Question-answer mode (Q&A mode): In Q&A mode, the MCU sends watchdog answers through SPI.

To select the Q&A mode, the MCU must set the WD_CFG bit (bit 5) in the safety-function configuration register (SAFETY_FUNC_CFG) while in the DIAGNOSTIC state. When the watchdog operates in Q&A mode, the MCU error signal monitor (ESM) may be used.

5.4.11 Watchdog Fail Counter, Status, and Fail Event

The watchdog includes a watchdog fail counter (WD_FAIL_CNT[2:0]) which increments because of *bad events* or decrements because of *good events*. When the value of the watchdog fail counter is 5 or more, the watchdog status is out-of-range and the ENDRV pin is low (the watchdog-enabled function is disabled).

When the watchdog fail counter is 4 or less, the watchdog status is in-range and the watchdog no longer disables the watchdog-enabled function. In this case, the device pulls up the ENDRV pin when the ENABLE_DRV control bit (in the SAFETY_CHECK_CTRL register) is set and when the device detects no other errors that impact the level of the ENDRV pin.

The watchdog fail counter operates independently of the state of the watchdog reset configuration bit (bit 3), WD_RST_EN, in the SAFETY_FUNC_CFG register.

The watchdog fail counter responds as follows:

- A *good event* decrements the fail counter by one, down to the minimum of zero.
- A *bad event* increments the fail counter by one, up to the maximum of seven.
- A *time-out event* increases the fail counter by one, up to the maximum of seven, and sets the TIME_OUT flag (WD_STATUS register, bit 1).

The definitions of *good event*, *bad event* and *time-out event* are listed [Section 5.4.14](#) and [Section 5.4.15](#).

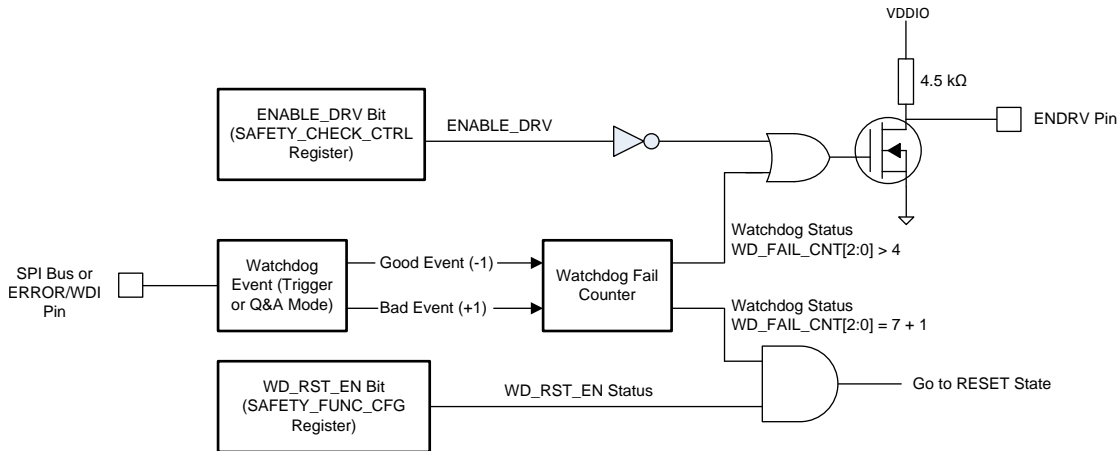

Figure 5-5. Watchdog Impact on ENDRV and RESET

Table 5-10. Watchdog Status for Range of the Watchdog Fail Counter Value

WATCHDOG FAIL COUNTER WD_FAIL_CNT[2:0]	000b THROUGH 100b	101b THROUGH 111b	111b
The watchdog status is based on the WD_FAIL_CNT[2:0] value.	Watchdog in-range	Watchdog is out-of-range	If the WD_RST_EN bit is set to 1, the NRES pin is pulled low, the device is in the RESET state on next "bad" or "time-out" event to the watchdog

The watchdog fail counter is initialized to a count of 5 when the device enters the DIAGNOSTIC state (after going through the RESET state) and when the device transitions from the DIAGNOSTIC state to the ACTIVE state.

When the watchdog fail counter reaches a count of 7, another *bad event* does not change the counter: the counter remains at 7. However, if the watchdog reset is enabled (WD_RST_EN bit in the SAFETY_FUNC_CFG register is set to 1), on the next *bad event* or *time-out event* (7 + 1) the device enters the RESET state and resets the MCU by pulling the NRES pin low. In the RESET state, the watchdog fail counter reinitializes to 5. If the watchdog fail counter is at seven when the WD_RST_EN bit is set to 1, the device immediately enters the RESET state without requiring another *bad event* or *time-out event*.

5.4.12 Watchdog Sequence

Each watchdog sequence begins with a Window 1 followed by a Window 2. The MCU can program the time periods of Window 1 (t_{WIN1}) and Window 2 (t_{WIN2}) with the WD_WIN1_CFG and WD_WIN2_CFG registers respectively when the device is in the DIAGNOSTIC state. When the device goes from the RESET state to the DIAGNOSTIC state, the watchdog sequence begins with the default t_{WIN1} and t_{WIN2} time periods.

Use Equation 1 and Equation 2 to calculate the minimum and maximum values for the t_{WIN1} time period. Use Equation 3 and Equation 4 to calculate the minimum and maximum values for the t_{WIN2} time period.

$$t_{WIN1_MIN} = [(RT[6:0] - 1) \times 0.55 \times 0.95] \text{ ms}$$

where

- The bits RT[6:0] are located in the WD_WIN1_CFG SPI register.

(1)

$$t_{WIN1_MAX} = (RT [6:0] \times 0.55 \times 1.05) \text{ ms}$$

where

- The bits RT[6:0] are located in the WD_WIN1_CFG SPI register.

(2)

$$t_{WIN2_MIN} = [(RW[4:0] + 1) \times 0.55 \times 0.95] \text{ ms}$$

where

- The bits RW[4:0] are located in the WD_WIN2_CFG SPI register.

(3)

$$t_{WIN2_MAX} = [(RW[4:0] + 1) \times 0.55 \times 1.05] \text{ ms}$$

where

- The bits RW[4:0] are located in the WD_WIN2_CFG SPI register.

(4)

If the MCU stops sending *events*, or stops *feeding the watchdog* during the watchdog sequence, the watchdog considers this lack of response from the MCU a *time-out event (no response event)*. This sets the TIME_OUT status bit (bit 1 in the WD_STATUS register) and increments the watchdog fail counter. Immediately following a *time-out event* the next watchdog sequence is started.

Based on the Window 1 and Window 2 time periods, the watchdog sequence and time-out time periods are calculated as follows:

$$t_{SEQUENCE_MIN} = t_{TIMEOUT_MIN} = t_{WIN1_MIN} + t_{WIN2_MIN} \quad (5)$$

$$t_{SEQUENCE_MAX} = t_{TIMEOUT_MAX} = t_{WIN1_MAX} + t_{WIN2_MAX} \quad (6)$$

The watchdog uses the internal system clock of the device ($\pm 5\%$ accuracy) as a time reference for creating the 0.55-ms watchdog time step. WINDOW 1 may be up to one 0.55-ms watchdog time step shorter than programmed as indicated by Equation 1.

NOTE

Because of the uncertainty in the Window 1 and Window 2 time periods, TI recommends using settings for Window 1 and Window 2 of two or higher. Window 2 could be set as low as one, assuming Window 1 is set to six or lower. The response from the MCU should be targeted to the mid point of known timing for Window 2. As Window 1 setting is increased above six, the device system-clock tolerance ($\pm 5\%$) becomes large compared to a setting of one in Window 2 not allowing for a known time range for a response in Window 2, so Window 2 setting must be scaled with Window 1 to allow timing margin.

5.4.13 MCU to Watchdog Synchronization

To synchronize the MCU with the watchdog sequence, the MCU can write to either the WIN1_CFG or WIN2_CFG registers to start a new watchdog sequence. After a write access to the WIN1_CFG or WIN2_CFG register by the MCU (even when these registers are locked or when the device is in the ACTIVE or the SAFE state), the device immediately starts a new watchdog sequence and increments the watchdog fail counter. Therefore a write access to the WD_WIN1_CFG or WD_WIN2_CFG register only takes effect in this new watchdog sequence.

When the MCU is synchronized with the watchdog sequence, a *good event* from the MCU immediately starts a new watchdog sequence. In this way, the MCU stays synchronized with the watchdog sequence.

See [Figure 6-11](#) for an example software flowchart of how to synchronize the MCU with the TPS65381A-Q1 watchdog.

5.4.14 Trigger Mode (Default Mode)

When the device goes from the RESET state to the DIAGNOSTIC state, the watchdog operates in trigger mode (default). The first watchdog sequence begins with the default t_{WIN1} and t_{WIN2} time periods. The watchdog receives the triggers from the MCU on the ERROR/WDI pin. A rising edge on the ERROR/WDI pin, followed by a falling edge on the ERROR/WDI pin after more than the required pulse time, $t_{WD_pulse(max)}$ (32 μ s), is a trigger. Even a waveform with a longer duration high than low is counted as a trigger if the rising and falling edges meet this requirement.

Window 1, called a CLOSE window, is the first window in the watchdog sequence. A trigger received in Window 1 is a *bad event* and ends Window 1, starts a new watchdog sequence and sets ANSWER_EARLY flag.

Window 2, called an OPEN window, follows Window 1. At a minimum, Window 2 lasts until a trigger is received. At a maximum, Window 2 lasts until the programmed t_{WIN2} time. A trigger received in Window 2 (OPEN) is a *good event*. A new watchdog sequence begins immediately after the watchdog receives a trigger in Window 2.

If the MCU stops sending triggers during the watchdog sequence, the watchdog considers this lack of response from the MCU a *time-out event (no response event)*. This sets the TIME_OUT status bit (bit 1 in the WD_STATUS register) and increments the watchdog fail counter. Immediately following a *time-out event* a new watchdog sequence is started.

The TIME_OUT flag can be useful for the MCU software to resynchronize the watchdog trigger pulse events to the required device watchdog timing. When resynchronizing in this way, the MCU detects the TIME_OUT flag being set. The TIME_OUT flag being set indicates the *time-out event* and the start of a new watchdog sequence. The MCU should send the trigger with timing so the trigger is in Window 2 (OPEN) of this new watchdog sequence.

NOTE

If an active SPI frame (nCS is low) is present when the *time-out event* occurs, the TIME_OUT flag is not latched (set) in the WD_STATUS register, but the watchdog fail counter still increments. Because the TIME_OUT flag is not latched, this impacts the resynchronization ability of the MCU and status monitoring. It is recommended to use the synchronization procedure outlined in section [Section 5.4.13](#).

In trigger mode, the watchdog uses a deglitch filter with the t_{WD_pulse} filter time and an internal system clock to create the internally generated watchdog pulse (see [Figure 5-6](#) and [Figure 5-7](#)).

The rising edge of the trigger on the ERROR/WDI pin must occur at least the $t_{WD_pulse(max)}$ time before the end of Window 2 (OPEN) to generate a good event.

The window duration times of Window 1 (CLOSE) and Window 2 (OPEN) are programmed through the WD_WIN1_CFG and WD_WIN2_CFG registers when the device is in the DIAGNOSTIC state. In trigger mode, the window duration time are as follows:

$$t_{WCW_MIN} \text{ (Trigger mode)} = t_{WIN1_MIN}$$

where

- WCW is a watchdog CLOSE window

(7)

$$t_{WCW_MAX} \text{ (Trigger mode)} = t_{WIN1_MAX}$$

where

- WCW is a watchdog CLOSE window

(8)

$$t_{WOW_MIN} \text{ (Trigger mode)} = t_{WIN2_MIN}$$

where

- WOW is a watchdog OPEN window

(9)

$$t_{WOW_MIN} \text{ (Trigger mode)} = t_{WIN2_MIN}$$

where

- WOW is a watchdog OPEN window

(10)

Use [Equation 1](#) and [Equation 2](#) to calculate the minimum and maximum values for the $t_{WIN1} = t_{WCW}$ time period. Use [Equation 3](#) and [Equation 4](#) to calculate the minimum and maximum values for the $t_{WIN2} = t_{WOW}$ time period.

Writing a new Window 1 or Window 2 time to the WD_WIN1_CFG or WD_WIN2_CFG register immediately begins a new watchdog sequence and increments the watchdog fail counter. A new watchdog sequence is started by a write even when WD_WIN1_CFG register and the WD_WIN2_CFG SPI register are locked because the device is not in DIAGNOSTIC state or the SPI command SW_LOCK is blocking a write update to the register values.

The watchdog trigger event is considered a *good-event* if received during a Window 2 (OPEN) window, and is considered a *bad-event* if received during Window 1 (CLOSE) window. A *good-event* ends the current watchdog sequence and starts a new watchdog sequence, therefore the MCU and device watchdog timing stay synchronized.

A *good-event*, *bad-event*, *time-out event*, power-up event, or power-down event ends the current watchdog sequence and starts a new watchdog sequence.

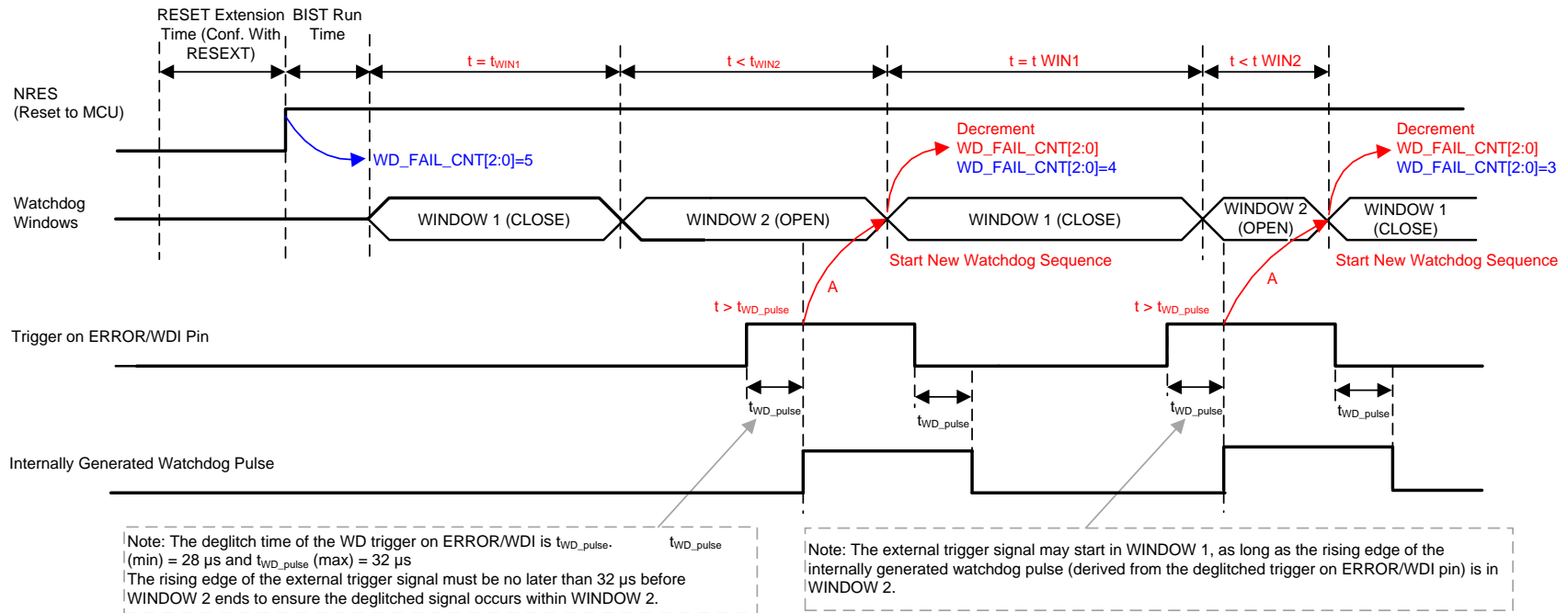

- A. When a *good event* is received in Window 2, 1 system clock-cycle (250 ns, typical) later the next watchdog sequence begins. Therefore the actual length of Window 2 depends on when the MCU sends the *good event*.

Figure 5-6. Example Cases for Good-Events in Trigger Mode

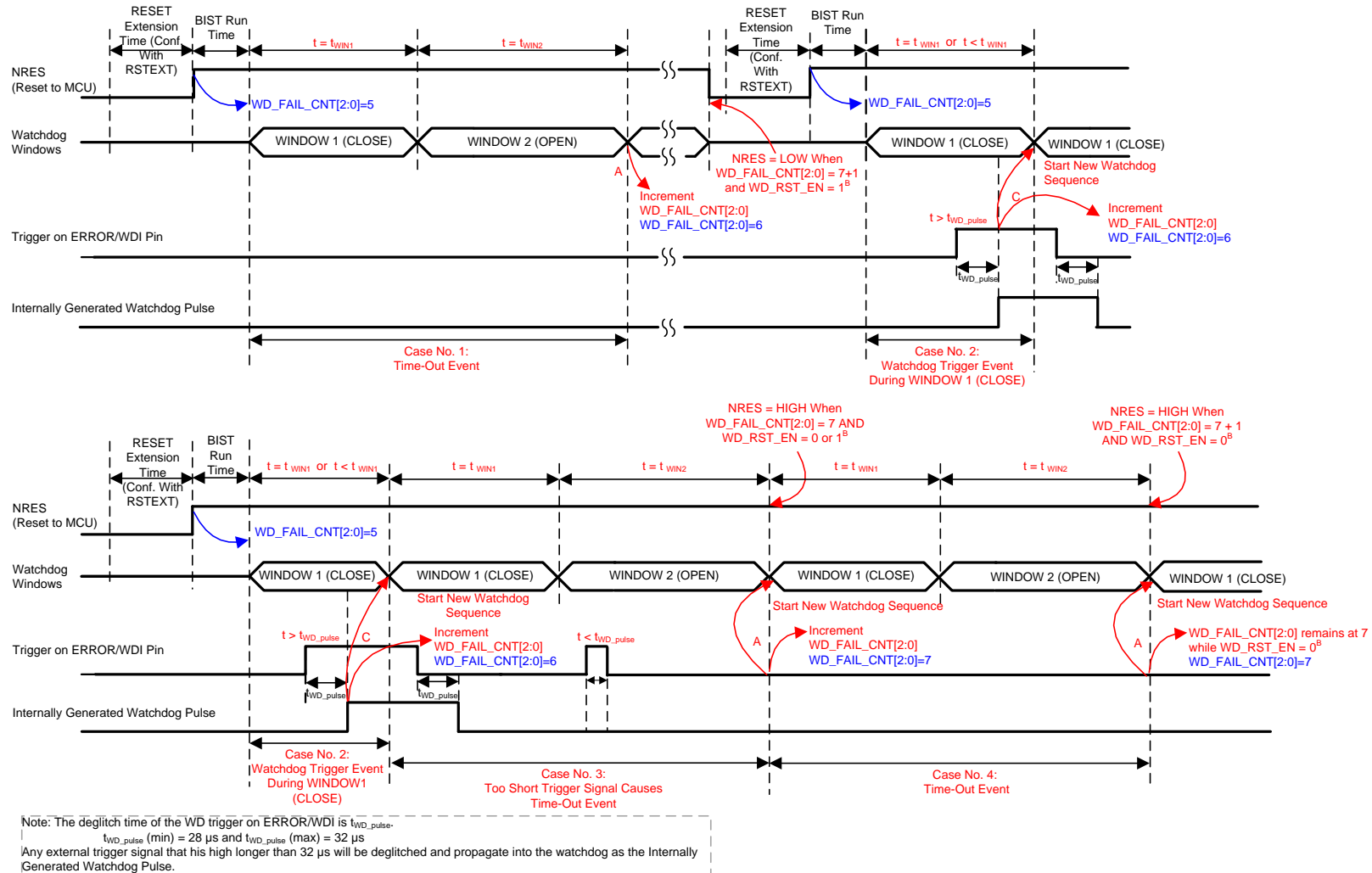

- A. When a *time-out event* occurs, 1 system clock-cycle (250 ns, typical) later, the next watchdog sequence begins.
- B. $WD_RST_EN = 0$ per default. To enable a reset from the watchdog once $WD_FAIL_CNT[2:0] = 7 + 1$, WD_RST_EN must be set to 1. The notation $WD_FAIL_CNT[2:0] = 7 + 1$ means the next (+ 1) *bad event* or *time-out event* if $WD_FAIL_CNT[2:0] = 7$ while $WD_RST_EN = 1$ will cause a transition to the RESET state. However, when $WD_RST_EN = 0$, the $WD_FAIL_CNT[2:0]$ counter does not increment past 7 and the watchdog does not cause a transition to the RESET state.
- C. When a *bad event* is received in Window 1, 1 system clock-cycle (250 ns, typical) later the next watchdog sequence begins. Therefore the actual length of Window 1 depends on when the MCU sends the *bad event*.

Figure 5-7. Example Cases for *Bad-Event* and *Time-out Events* in Trigger Mode

5.4.15 Q&A Mode

Setting the WD_CFG bit in the SAFETY_FUNC_REG register to 1 when the device is in the DIAGNOSTIC state configures the watchdog for Q&A (question and answer) mode. In Q&A mode, the device provides a *question (or TOKEN)* for the MCU in the WD_TOKEN_VALUE register. The MCU performs a fixed series of arithmetic operations on the question to calculate the required 32-bit answer. This answer is split into four answer bytes or responses. The MCU writes these answer bytes through SPI one byte at a time into the WD_ANSWER register. The device verifies that the MCU returned the answer bytes within the specified timing windows, and that the answer bytes are correct.

A *good event* occurs when the MCU sends the correct answer bytes calculated for the current question within the correct watchdog window and in the correct order.

A *bad event* occurs when one of the events that follows occur:

- The MCU sends the correct answer bytes, but not in the correct watchdog window.
- The MCU sends incorrectly calculated answer bytes.
- The MCU returns correct answer bytes in the wrong order (sequence).

If the MCU stops sending answer bytes during the watchdog sequence, the watchdog considers this lack of response from the MCU a *time-out event (no response event)*. This sets the TIME_OUT status bit (bit 1 in the WD_STATUS register) and increments the watchdog fail counter. Immediately following a *time-out event* a new watchdog sequence is started.

The TIME_OUT flag can be useful for the MCU software to resynchronize the watchdog answer timing to the required device watchdog timing. When resynchronizing in this way, the MCU detects the TIME_OUT flag being set. The TIME_OUT flag being set indicates the *time-out event* and the start of a new watchdog sequence. The MCU should send the answer bytes with timing so they will be in the correct windows of the new watchdog sequence.

NOTE

If an active SPI frame (nCS is low) is present when the *time-out event* occurs, the TIME_OUT flag is not latched (set) in the WD_STATUS register, but the watchdog fail counter is still incremented. Because the TIME_OUT flag is not latched this impacts the resynchronization ability of the MCU and status monitoring. It is recommended to use the synchronization procedure outlined in section [Section 5.4.13](#).

NOTE

In Q&A mode, each watchdog sequence starts with Window 1 (OPEN) followed by Window 2 (CLOSE). The OPEN and CLOSE references for Q&A mode are reversed with respect to those of trigger mode, but the order of the Window 1 and Window 2 is the same as are the registers containing the setting for each window, WD_WIN1_CFG and WD_WIN2_CFG.

5.4.15.1 Watchdog Q&A Related Definitions

The Q&A mode definitions are:

Question (Token) The question (token) is a 4-bit word (see [Section 5.4.15.3](#)).

The watchdog provides the question (token) to the MCU when the MCU reads the question (TOKEN[3:0]) from the WD_TOKEN_VALUE register.

The MCU can request each new question (token) at the start of the watchdog sequence, but this is not required to calculate the answer. The MCU can also generate the question by implementing the question generation circuit as shown in [Figure 5-9](#). Nevertheless, the answer and, therefore the answer bytes, are always based on the question generated inside the watchdog of the device. So, if the MCU generates a wrong question and gives answer bytes calculated from a wrong question, the watchdog detects a *bad event*.

A new question (token) is generated only when a *good event* occurred in the previous watchdog sequence causing the token counter (internal counter) to increment and generate

a new question (token) as shown in figure [Figure 5-9](#).

Answer (Response) The answer (response) is a 32-bit word that is split into four answer bytes or responses: Answer-3 (WD_TOKEN_RESP_3), Answer-2 (WD_TOKEN_RESP_2), Answer-1 (WD_TOKEN_RESP_1), and Answer-0 (WD_TOKEN_RESP_0).

The watchdog receives an answer byte when the MCU writes to the watchdog answer register (the WD_ANSW[7:0] bits in the WD_ANSWER register).

For each question, the watchdog requires four correct answer bytes from the MCU in the correct timing and order (sequence). Answer-3, Answer-2, and Answer-1 can be in Window 1 or Window 2 in the correct order, and Answer-0 must be in Window 2 to be detected as a *good event*.

5.4.15.2 Watchdog Sequence in Q&A Mode

The watchdog sequence in Q&A mode ends after the MCU writes the fourth answer byte, Answer-0 (WD_TOKEN_RESP_0), or after a time-out event. A new watchdog sequence starts after the previous watchdog sequence ends.

The window duration times of Window 1 (OPEN) and Window 2 (CLOSE) are programmed through the WD_WIN1_CFG and WD_WIN2_CFG registers when the device is in the DIAGNOSTIC state. In Q&A mode, the window duration time are as follows:

$$t_{WOW_MIN} (Q\&A \text{ mode}) = t_{WIN1_MIN}$$

where

- WOW is a watchdog OPEN window

(11)

$$t_{WOW_MAX} (Q\&A \text{ mode}) = t_{WIN1_MAX}$$

where

- WOW is a watchdog OPEN window

(12)

$$t_{WCW_MIN} (Q\&A \text{ mode}) = t_{WIN2_MIN}$$

where

- WCW is a watchdog CLOSE window

(13)

$$t_{WCW_MIN} (Q\&A \text{ mode}) = t_{WIN2_MIN}$$

where

- WCW is a watchdog CLOSE window

(14)

Use [Equation 1](#) and [Equation 2](#) to calculate the minimum and maximum values for the $t_{WIN1} = t_{WOW}$ time period. Use [Equation 3](#) and [Equation 4](#) to calculate the minimum and maximum values for the $t_{WIN2} = t_{WCW}$ time period.

Writing a new Window 1 or Window 2 time to the WD_WIN1_CFG or WD_WIN2_CFG register immediately begins a new watchdog sequence and increments the watchdog fail counter. A new watchdog sequence is started by a write even when WD_WIN1_CFG register and the WD_WIN2_CFG SPI register are locked because the device is not in DIAGNOSTIC state or the SPI command SW_LOCK is blocking a write update to the register values.

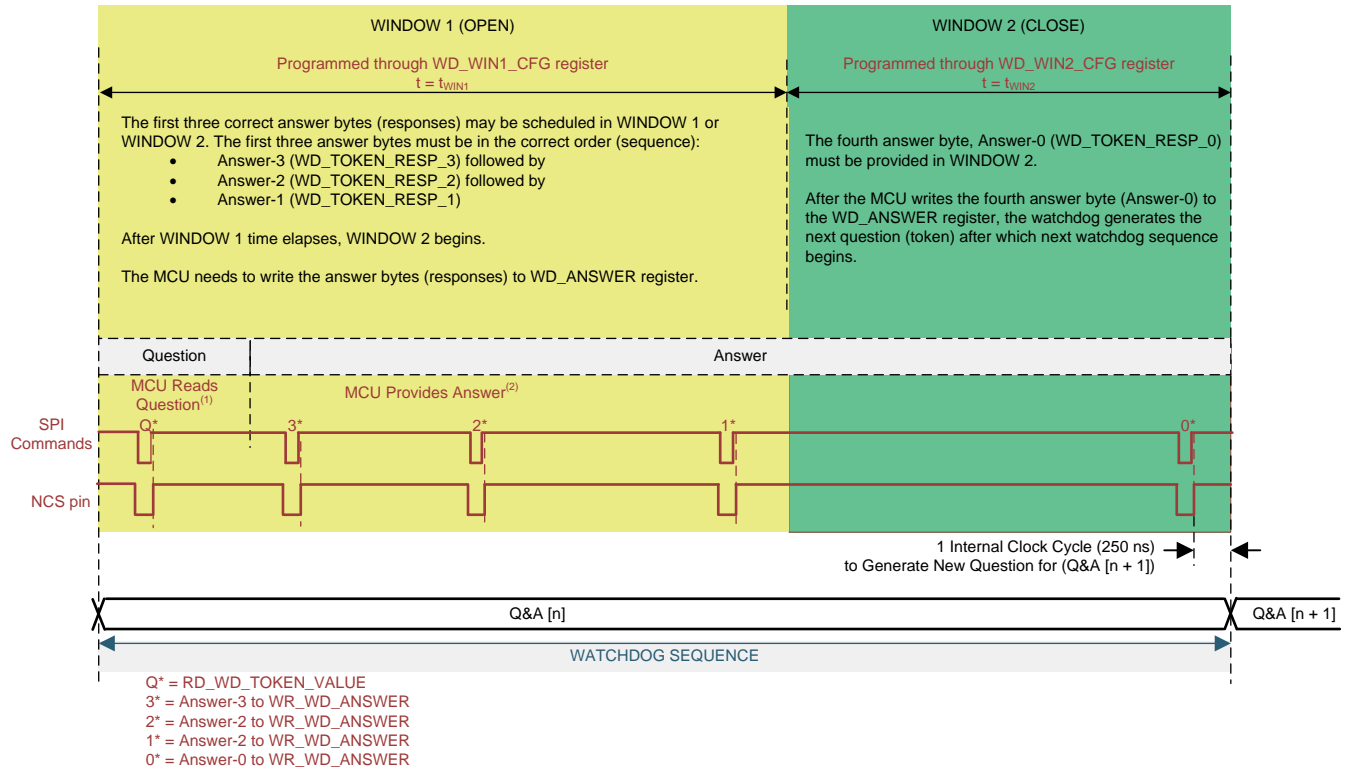

- (1) The MCU is not required to read the question (token). The MCU can begin giving the correct answer bytes Answer-3, Answer-2, Answer-1, anywhere in Window 1 or Window 2. The new question (token) is generated and a new watchdog sequence started within 1 system clock cycle after the final Answer-0 as long as the answer was a *good event*. A *bad event* or *time-out event* causes a new watchdog sequence to start, however a new question (token) is not generated.
- (2) The MCU can put other SPI commands in-between the WR_WD_ANSWER commands (even rerequesting the question). These SPI commands have no influence on the detection of a *good event*, as long as the four correct answer bytes are in the correct order, and the fourth correct answer byte is provided in Window 2.

Figure 5-8. Watchdog Sequence in Q&A Mode

5.4.15.3 Question (Token) Generation

The watchdog uses a 4-bit token counter (TOKEN_CNT[3:0] bits in Figure 5-9), and a 4-bit Markov chain to generate a 4-bit question (token). The MCU can read this question in the WD_TOKEN_VALUE register, TOKEN[3:0] bits. The watchdog generates a new question when the token counter increments, which only occurs when the watchdog detects a *good event*. The watchdog does not generate a new question when it detects a *bad event* or a *time-out event*. The watchdog does not generate a new question for a watchdog sequence that starts after the MCU writes to the WD_WIN1_CFG or WD_WIN2_CFG registers.

The token counter provides a clock pulse to the Markov chain when it transitions from 1111b to 0000b. The question counter and the Markov chain are set to the singular default value of 0000b when the device completes the LBIST (either a manual LBIST run or the automotive LBIST run initiated on the transition from the RESET to DIAGNOSTIC state). To leave the singular point, the feedback logic combination is implemented.

Figure 5-9 shows the logic combination for the question (token) generation. The question is in the WD_TOKEN_VALUE register, TOKEN[3:0] bits.

The logic combination of the token counter with the WD_ANSW_CNT[1:0] status bits (in the WD_STATUS register) generates the reference answer bytes as shown in Figure 5-9.

4-bit LFSR Polynomial Equation¹

- FDBK[2:1] = 2b'00: $y = x^4 + x^3 + 1$ (Default Value)
- FDBK[2:1] = 2b'01: $y = x^4 + x^2 + 1$
- FDBK[2:1] = 2b'10: $y = x^3 + x^2 + 1$
- FDBK[2:1] = 2b'11: $y = x^4 + x^3 + x^2 + 1$

Equivalent for Default LFSR Polynomial (Default FDBK value)

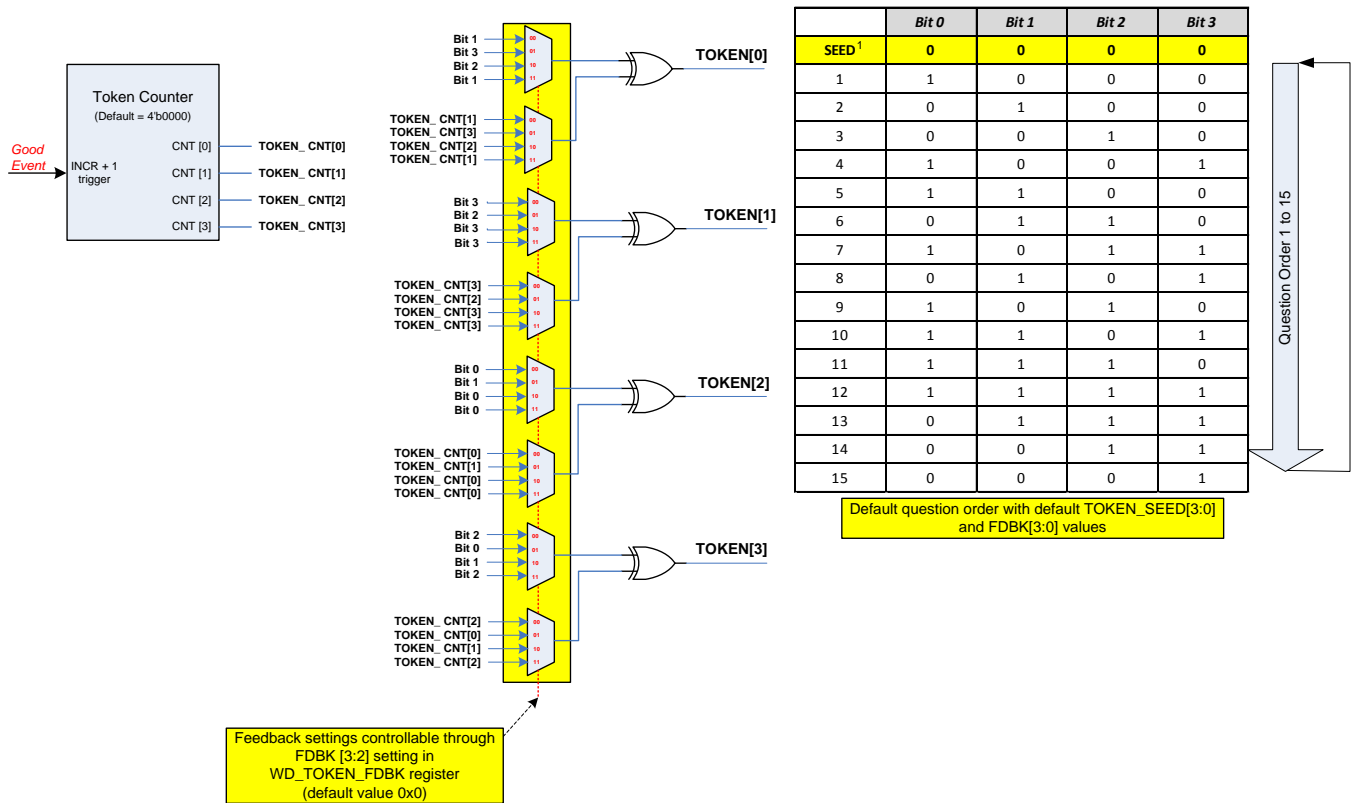
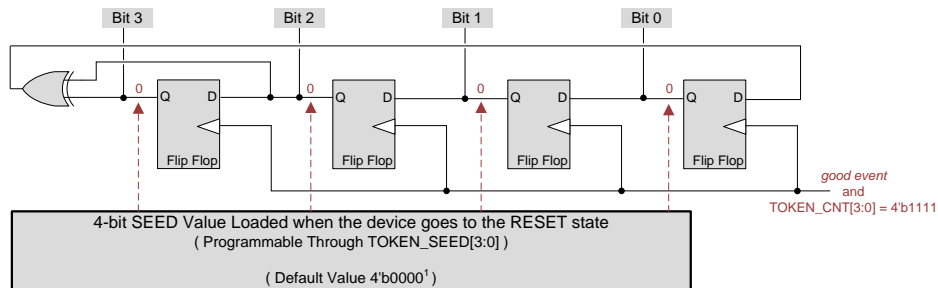

(1) A value of 0000b is a special seed and equates to 0001b, including the default loading of 0000b during power up.

Figure 5-9. Watchdog Question (Token) Generation

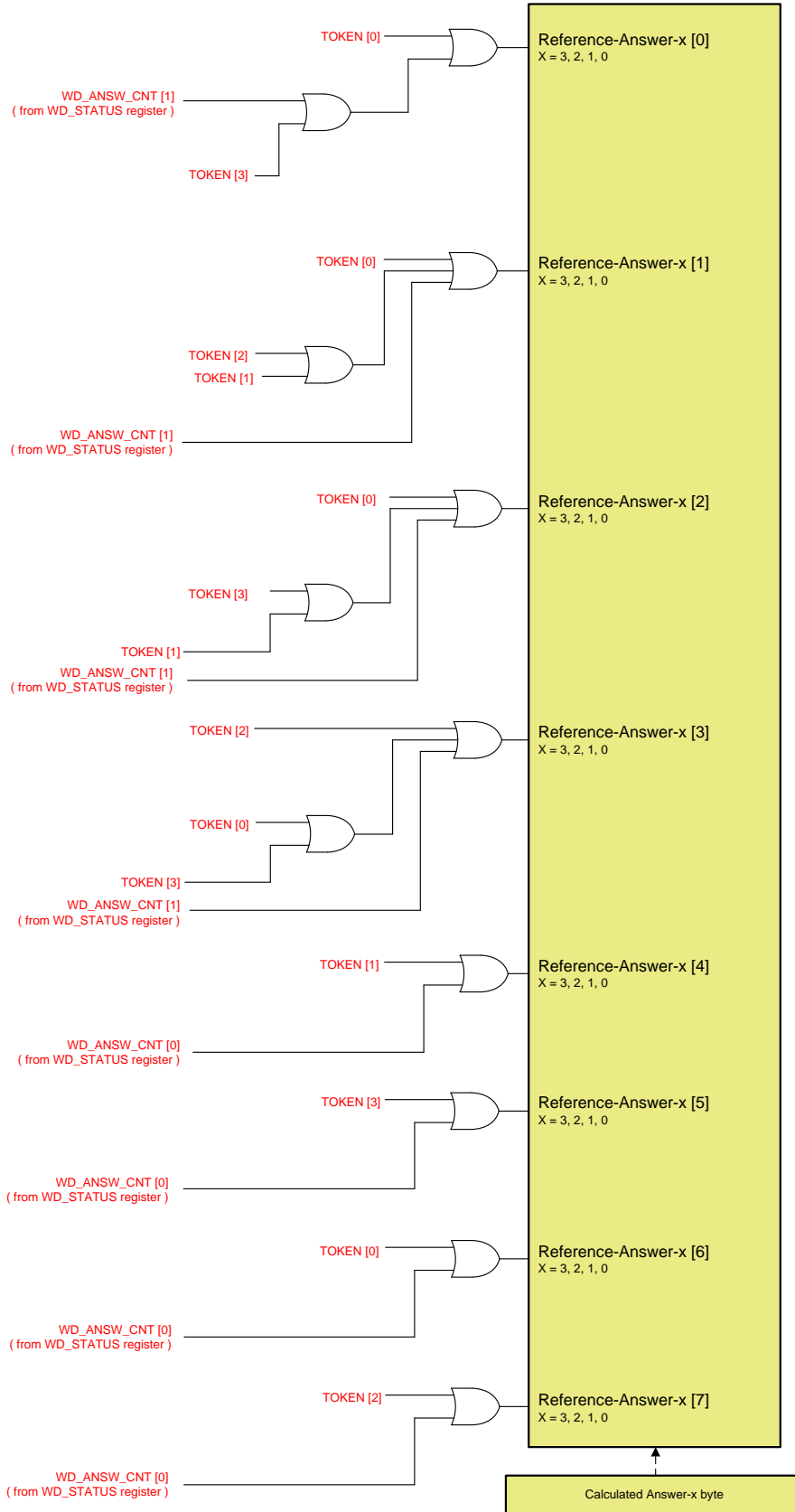

Figure 5-10. Watchdog Answer Calculation

5.4.15.4 Answer Comparison and Reference Answer

The 2-bit, watchdog-answer counter, WD_ANSW_CNT[1:0], in the WD_STATUS register counts the number of received answer bytes and controls the generation of the reference Answer-x byte as shown in [Figure 5-10](#). At the start of each watchdog sequence, the default value of the WD_ANSW_CNT[1:0] is 11b to indicate that the watchdog expects the MCU to write Answer-3 (WD_RESP_3) in the WD_ANSWER register.

5.4.15.4.1 Sequence of the 2-bit Watchdog Answer Counter

The sequence of the 2-bit, watchdog answer counter, WD_ANSW[1:0], is as follows for each counter value:

- WD_ANSW_CNT[1:0] = 11b:
 - The watchdog calculates reference Answer-3
 - A write access occurs: the MCU writes Answer-3 (WD_TOKEN_RESP_3) byte in the WD_ANSWER register.
 - The watchdog compares the reference Answer-3 with the Answer-3 byte in the WD_ANSWER register.
 - The watchdog decrements the WD_ANSW_CNT[1:0] bits to 10b and updates the ANSWER_ERR flag bit.
- WD_ANSW_CNT[1:0] = 10b:
 - The watchdog calculates reference Answer-2
 - A write access occurs: the MCU writes Answer-2 (WD_TOKEN_RESP_2) byte in the WD_ANSWER register.
 - The watchdog compares the reference Answer-2 with the Answer-2 byte in the WD_ANSWER register.
 - The watchdog decrements the WD_ANSW_CNT[1:0] bits to 01b and updates the ANSWER_ERR flag bit.
- WD_ANSW_CNT[1:0] = 01b:
 - The watchdog calculates reference Answer-1
 - A write access occurs: the MCU writes Answer-1 (WD_TOKEN_RESP_1) byte in the WD_ANSWER register.
 - The watchdog compares the reference Answer-1 with the Answer-1 byte in the WD_ANSWER register.
 - The watchdog decrements the WD_ANSW_CNT[1:0] bits to 00b and updates the ANSWER_ERR flag bit.
- WD_ANSW_CNT[1:0] = 00b:
 - The watchdog calculates reference Answer-0
 - A write access occurs: the MCU writes Answer-0 (WD_TOKEN_RESP_0) byte in the WD_ANSWER register.
 - The watchdog compares the reference Answer-0 with the Answer-0 byte in the WD_ANSWER register.
 - The watchdog updates the ANSWER_ERR flag bit.
 - The watchdog starts a new watchdog sequence and sets the WD_ANSW_CNT[1:0] to 11b.

Table 5-11. Set of Questions (Tokens) and Corresponding Answer Bytes Using Default Setting of WD_TOKEN_FDBK Register

QUESTION (TOKEN) IN WD_TOKEN_VALUE REGISTER	WD ANSWER (TO BE WRITTEN INTO WD_ANSW REGISTER)			
	Answer-3 (WD_TOKEN_RESP_3)	Answer-2 (WD_TOKEN_RESP_2)	Answer-1 (WD_TOKEN_RESP_1)	Answer-0 (WD_TOKEN_RESP_0)
TOKEN [3:0]	WD_ANSW_CNT [1:0] = 11b	WD_ANSW_CNT [1:0] = 10b	WD_ANSW_CNT [1:0] = 01b	WD_ANSW_CNT [1:0] = 00b
0h	FFh	0Fh	F0h	00h
1h	B0h	40h	BFh	4Fh
2h	E9h	19h	E6h	16h
3h	A6h	56h	A9h	59h
4h	75h	85h	7Ah	8Ah
5h	3Ah	CAh	35h	C5h
6h	63h	93h	6Ch	9Ch
7h	2Ch	DCh	23h	D3h
8h	D2h	22h	DDh	2Dh
9h	9Dh	6Dh	92h	62h
Ah	C4h	34h	CBh	3Bh
Bh	8Bh	7Bh	84h	74h
Ch	58h	A8h	57h	A7h
Dh	17h	E7h	18h	E8h
Eh	4Eh	BEh	41h	B1h
Fh	01h	F1h	0Eh	FEh

5.4.15.5 Watchdog Q&A Mode Sequence Events and WD_STATUS Register Updates

The watchdog sequence events are as follows for the different scenarios listed:

- A *good event* occurs when all answer bytes are correct in value (the ANSWER_ERR bit is cleared to 0) and timing. For such a good event, then the events that follow occur:
 - The watchdog fail counter, WD_FAIL_CNT[2:0], decrements by one.
 - The token counter increments by one, causing a new question (token) to be generated.
 - The SEQ_ERR bit resets.
 - The ANSWER_EARLY bit resets.
- A *bad event* occurs when all answer bytes are correct in value (the ANSWER_ERR bit is cleared to 0) but not in correct timing. For such a bad event, then the events that follow occur:
 - The watchdog fail counter, WD_FAIL_CNT[2:0], increments by one.
 - The token counter does not change, thus the question (token) does not change.
 - The SEQ_ERR bit is set.
 - The ANSWER_EARLY bit is set.
- A *bad event* occurs when one or more of the answer bytes are not correct in value (the ANSWER_ERR bit is set to 1) but in correct timing. For such a bad event, then the events that follow occur:
 - The watchdog fail counter, WD_FAIL_CNT[2:0], increments by one.
 - The token counter does not change, thus the question (token) does not change.
 - The SEQ_ERR bit is set
 - The ANSWER_EARLY bit is reset

- A *bad event* occurs when one or more of the answer bytes are not correct in value (the ANSWER_ERR status bit is set to 1) and not in correct timing. For such a bad event, then the events that follow occur:
 - The watchdog fail counter, WD_FAIL_CNT[2:0], increments by one
 - The token counter does not change, thus the question (token) does not change.
 - The SEQ_ERR bit is set.
 - The ANSWER_EARLY bit is set.
- In case a *time-out event* occurs, then the events that follow occur:
 - The watchdog fail counter, WD_FAIL_CNT[2:0], increments by one.
 - The token counter does not change, thus the question (token) does not change.
 - The TIME_OUT bit is set.
- In case the MCU writes to registers WD_WIN1_CFG or WD_WIN2_CFG, the events that follow occur:
 - The watchdog fail counter, WD_FAIL_CNT[2:0], increments by one.
 - The WD_CFG_CHG bit is set.

Table 5-12. WD_STATUS Bits Versus Possible Watchdog Sequence Events

WATCHDOG SEQUENCE EVENTS					WD_STATUS REGISTER BITS			
All MCU Answer Bytes Correct?	Answer-0 Arrived During WINDOW 2 (CLOSE)	Answer-0 Arrived During WINDOW 1 (OPEN)	Time-out Occurred While Waiting for Answer?	WINDOW 1 or WINDOW 2 Duration Changed?	WD_CFG_CHG	SEQ_ERR	TIME_OUT	ANSWER_EARLY
Yes	Yes	No	No	No	0	0	0	0
Yes	No	Yes	No	No	0	0	0	1
No	Yes	No	No	No	0	1	0	0
No	No	Yes	No	No	0	1	0	1
Yes (first 3 Answer-x)	No	No	Yes	No	0	0	1	0
No	No	No	Yes	No	0	1	1	0
—	—	—	—	Yes	1	0	0	0

5.4.16 MCU Error Signal Monitor (MCU ESM)

This block monitors the external MCU error conditions signaled from the MCU to the device through the ERROR/WDI input pin. The MCU ESM is configurable to monitor two different signaling options depending which functional safety architecture MCU family is being monitored and how the specific MCU family indicates on the error or fault output pin improper operation. The MCU ESM mode is selected through the ERROR_CFG bit in the SAFETY_FUNC_CFG register.

In TMS570 mode the ESM detects a low-pulse signal with a programmable low-pulse duration threshold (see [Section 5.4.16.1](#)). This mode is selected when the ERROR_CFG bit is set to 1. In PWM mode the ESM detecting a PWM signal with a programmable frequency and duty cycle (see [Section 5.4.16.2](#)). This mode is selected when the ERROR_CFG bit is cleared to 0 (default). PWM mode can be used as an external clock-monitor function.

The MCU ESM is deactivated by default. To activate it, clear the NO_ERROR bit to 0 in the SAFETY_CHECK_CTRL register.

NOTE

Activating the MCU ESM is only recommended when the watchdog is configured in Q&A mode, otherwise the ERROR/WDI pin is used both for watchdog trigger input and MCU error signaling.

The low-signaling duration threshold (for TMS570 mode) or the expected PWM low-pulse duration (for PWM mode) is set through the SAFETY_ERR_PWM_L register. The expected PWM high-pulse duration (for PWM mode) is set through the SAFETY_ERR_PWM_H register. A detected MCU signaling error is indicated when the ERROR_PIN_FAIL bit in the SAFETY_ERR_STAT register is set to 1.

NOTE

An update to a SAFETY_ERR_PWM_x register (only possible in the DIAGNOSTIC state) has an immediate effect. Therefore, if the MCU writes a new value to the SAFETY_ERR_PWM_x register which is less than the value of the current pulse-duration counter value, the MCU ESM immediately detects an error condition on the ERROR/WDI pin. The pulse duration counter then reinitializes to 0 and sets the ERROR_PIN_FAIL bit to 1.

When the TPS65381A-Q1 device is in the DIAGNOSTIC state, the MCU can emulate a signaling error (emulated fault-injection) for a diagnostic check of the error-signal monitor by checking the status of the ERROR_PIN_FAIL bit while the NO_ERROR bit is cleared to 0 (MCU ESM enabled) without a transition to the SAFE state.

NOTE

To perform an MCU ESM diagnostic check of the pin while in the DIAGNOSTIC state the following procedure can be used. The ERROR/WDI pin is edge triggered.

1. Clear the ERROR_PIN_FAIL bit by clearing it to 0 in the SAFETY_ERR_STAT register.
2. Verify the ERROR_PIN_FAIL bit is not reset to 1 when the MCU ESM is enabled.
3. Inject a failure on the ERROR/WDI pin specific to the MCU ESM mode of operation.
4. Verify the ERROR_PIN_FAIL bit is set to 1 and the ENDRV pin is low even if the ENABLE_DRV bit is set to 1.
5. Remove the injected failure.
6. Write 0 to clear the ERROR_PIN_FAIL bit.
7. Confirm the ERROR_PIN_FAIL bit was cleared by reading back the SAFETY_ERR_STAT register.
8. Confirm the ENDRV pin returned HIGH when the ENABLE_DRV bit is set to 1, assuming no other conditions exist that block ENDRV from being HIGH (see [Figure 5-14](#)).

When the TPS65381A-Q1 device is in the ACTIVE state, a detected MCU signaling error causes a transition to the SAFE state. A dedicated 4-bit error counter, the DEV_ERR_CNT[3:0] bits in the SAFETY_ERR_STAT register, counts the transitions from the ACTIVE state to the SAFE state.

The module is covered by the logic BIST (LBIST).

5.4.16.1 TMS570 Mode

An error condition is detected when the ERROR/WDI pin remains low longer than the programmed amount of time set by the SAFETY_ERR_PWM_L register. The programmable time range is 5 μ s to 1.28 ms (typical), with 5- μ s steps ($\pm 5\%$).

The SAFETY_ERR_PWM_L register must be set to the desired value based on the maximum required time for the TMS570 MCU to detect an error or fault and to potentially recover from or correct the error or fault.

The LOW duration time is as follows:

$$t_{\text{TMS570_LOW_MIN}} = (\text{PWML}[7:0]) \times 5 \mu\text{s} \times 0.95 \quad (15)$$

$$t_{\text{TMS570_LOW_MAX}} = (\text{PWML}[7:0] + 1) \times 5 \mu\text{s} \times 1.05 \quad (16)$$

Use [Equation 15](#) and [Equation 16](#) to calculate the minimum and maximum values for the LOW duration, $t_{\text{TMS570_LOW}}$. [Figure 5-11](#) shows the error-detection case scenarios.

NOTE

The SAFETY_ERR_PWM_L register (PWML[7:0]) should be configured with a minimum of 1 (01h) in the register.

The low-pulse monitoring on the ERROR/WDI pin is implemented as follows:

- When the NO_ERROR bit is cleared to 0, every falling edge on the ERROR/WDI pin reinitializes the low-pulse duration counter to 0 within one system clock-cycle (250 ns $\pm 5\%$).
- After reinitialization, the low-pulse counter restarts one system clock-cycle (250 ns $\pm 5\%$).
- The low-pulse duration counter increases every 5 μ s (with $\pm 5\%$ accuracy) as long as the ERROR/WDI pin is low. A rising edge on the ERROR/WDI pin stops the low-pulse duration counter.
- When low-pulse duration counter is equal to the SAFETY_ERR_PWM_L register setting, an error is detected.

The ERROR_PIN_FAIL bit in the SAFETY_ERR_STAT register is set within one system clock cycle (250 ns $\pm 5\%$) after detecting an MCU signaling error. When the device is in the ACTIVE state, a transition to the SAFE state occurs after one more system clock-cycle.

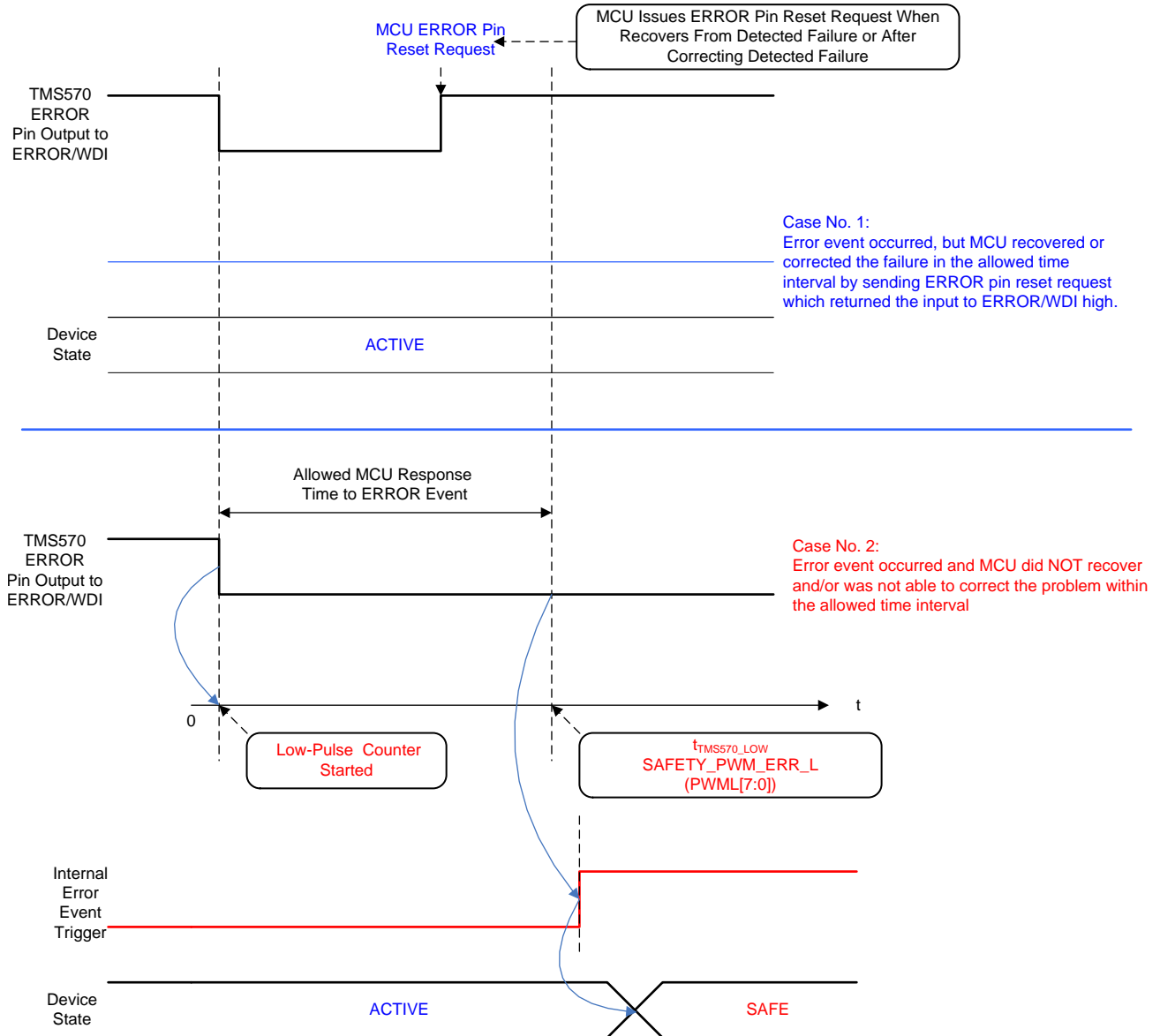

Figure 5-11. Error Detection Case Scenarios in TMS570 Mode

5.4.16.2 PWM Mode

An error condition is detected when one of the following occurs on the ERROR/WDI pin:

- The ERROR/WDI pin high-pulse duration exceeds the threshold value programmed by the PWM_H register.
- The ERROR/WDI pin low-pulse duration exceeds the threshold value programmed by the PWM_L register.

The MCU ESM does NOT detect an MCU signaling error on the ERROR/WDI pin if both of the following occurs:

- The ERROR pin high-pulse duration is less than the threshold value programmed by the PWM_H register.
- The ERROR pin low-pulse duration is less than the threshold value programmed by the PWM_L register.

The programmable time range for the expected HIGH and LOW pulse duration is 15 μ s to 3.8 ms (typical), with 15- μ s resolution steps ($\pm 5\%$). The HIGH and LOW pulse duration times are programmed through the SAFETY_ERR_PWM_H and SAFETY_ERR_PWM_L registers when the device is in the DIAGNOSTIC state. The pulse duration time are as follows:

$$t_{\text{PWM_HIGH_MIN}} = (\text{PWMH}[7:0]) \times 15 \mu\text{s} \times 0.95 \quad (17)$$

$$t_{\text{PWM_HIGH_MAX}} = (\text{PWMH}[7:0] + 1) \times 15 \mu\text{s} \times 1.05 \quad (18)$$

$$t_{\text{PWM_LOW_MIN}} = (\text{PWML}[7:0]) \times 15 \mu\text{s} \times 0.95 \quad (19)$$

$$t_{\text{PWM_LOW_MAX}} = (\text{PWML}[7:0] + 1) \times 15 \mu\text{s} \times 1.05 \quad (20)$$

Use [Equation 17](#) and [Equation 18](#) to calculate the minimum and maximum values for the HIGH pulse duration, $t_{\text{PWM_HIGH}}$. Use [Equation 19](#) and [Equation 20](#) to calculate the minimum and maximum values for the LOW pulse duration, $t_{\text{PWM_LOW}}$.

NOTE

The SAFETY_ERR_PWM_H (PWMH[7:0]) and SAFETY_ERR_PWM_L (PWML[7:0]) register should be configured with a minimum of 1 (01h) in the registers.

The monitoring of the high-pulse duration and low-pulse duration is implemented as follows:

LOW pulse monitoring:

- Every falling edge on the ERROR/WDI pin, or setting the NO_ERROR bit from 1 to 0 when the ERROR/WDI pin is low, reinitializes the low-pulse duration counter to 0 within one system clock-cycle (250 ns $\pm 5\%$).
- After reinitialization, the low-pulse counter restarts after one system clock-cycle (250 ns $\pm 5\%$).
- The low-pulse duration counter increases every 15 μ s ($\pm 5\%$) while the ERROR/WDI pin remains low.
- When the low-pulse duration counter is equal to the SAFETY_ERR_PWM_L register setting, an error is detected.

HIGH pulse monitoring:

- Every rising edge on the ERROR/WDI pin, or setting the NO_ERROR bit from 1 to 0 when the ERROR/WDI pin is high, reinitializes the high-pulse duration counter to 0 within one system clock-cycle (250 ns $\pm 5\%$).
- After reinitialization, the high-pulse counter restarts after one system clock-cycle (250 ns $\pm 5\%$).
- The high-pulse duration counter increases every 15 μ s (with $\pm 5\%$ accuracy) while the ERROR/WDI pin remains high.
- When the high-pulse duration counter is equal to the SAFETY_ERR_PWM_H register setting, an error is detected.

NOTE

The ERROR/WDI pin is edge triggered, to synchronize the MCU to the MCU ESM module, while in the DIAGNOSTIC state the MCU should start sending the desired PWM signal. On the first falling or rising edge the MCU ESM detects the edge and starts the internal timers in sync with the edge so the MCU and MCU ESM are synchronized. The MCU ESM resynchronizes to the MCU on every rising and falling edge. While in the DIAGNOSTIC state, when synchronization has occurred the ERROR_PIN_FAIL flag should be cleared.

The ERROR_PIN_FAIL bit in the SAFETY_ERR_STAT register is set within one system clock cycle (250 ns \pm 5%) after detecting an MCU signaling error. When the device is in the ACTIVE state, a transition to the SAFE state occurs after one more system clock-cycle.

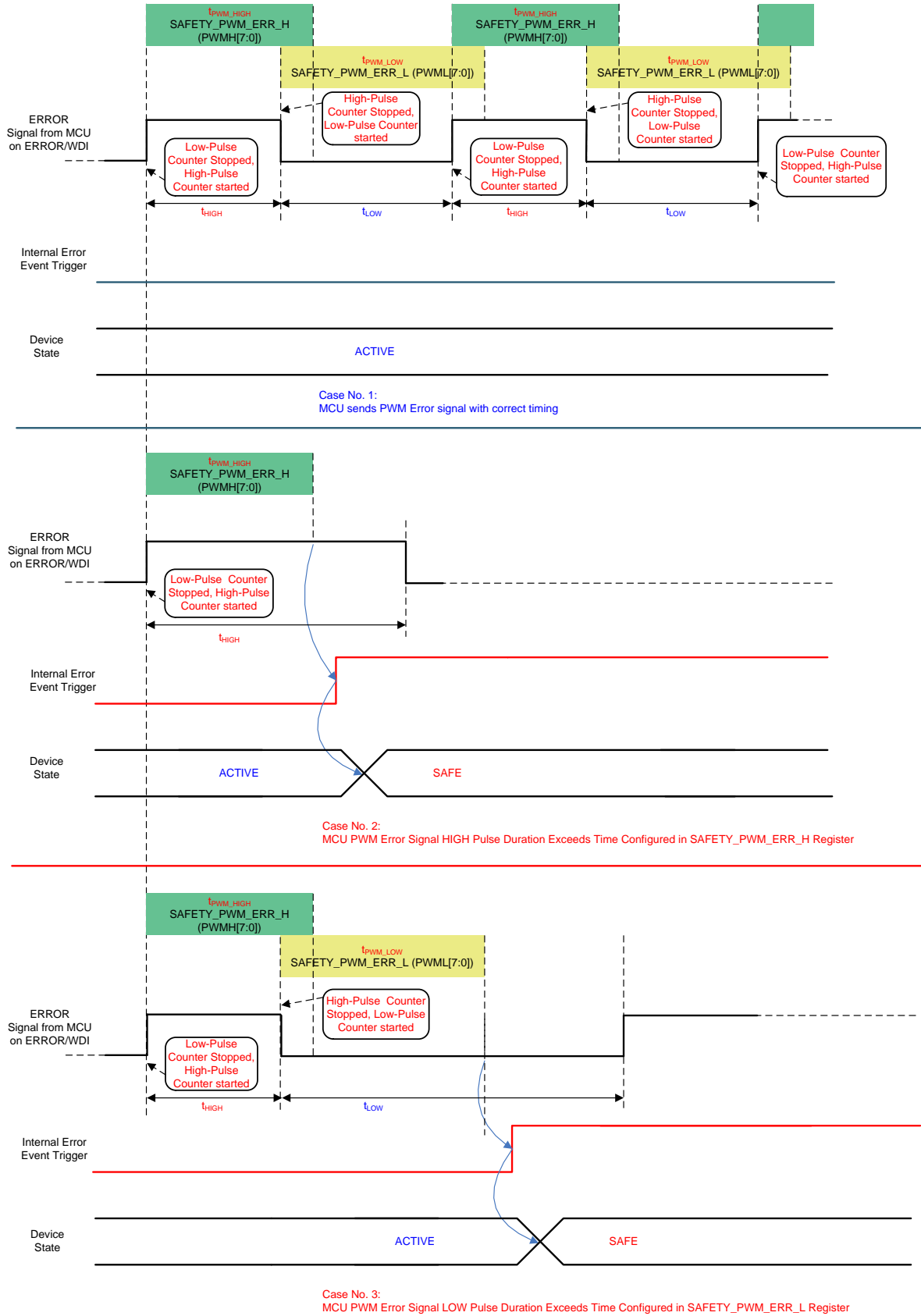

Figure 5-12. Error Detection Case Scenarios in PWM Mode

5.4.17 Device Configuration Register Protection

This function offers a mechanism to help protect safety SPI-mapped registers by means of SPI write-access protection and CRC check.

The register access protection includes two distinctive features:

- A register cannot be written after write-access lock protection is set. The lock is cleared by software or by a power-on reset.
- CRC protection for configuration registers.

A CRC occurs on safety data after a SPI write updates to verify the SPI register contents are correctly programmed. The CRC controller is a diagnostic module, which performs the CRC to verify the integrity of the SPI-mapped register space. A signature representing the content of the safety registers is obtained when the content is read into the CRC controller. The responsibility of the CRC controller is to calculate the signature for a set of data and then compare the calculated signature value against a predetermined good-signature value. The predetermined CRC signature value is stored in the SAFETY_CFG_CRC register. The external MCU uses the SAFETY_CHECK_CTRL register to enable a CRC check and the SAFETY_STAT_2 register to monitor the status. When enabled, a CRC check on the configuration registers is performed. In case of a detected signature error, the CFG_CRC_ERR flag is set in the SAFETY_STAT_2 SPI register. The device state and the ENDRV pin state remain unchanged. In case of a detected checksum error with the TPS65381A-Q1 device in the DIAGNOSTIC state, clearing the CFG_CRC_EN bit to 0 brings the TPS65381A-Q1 device into the SAFE state (the ENDRV pin is pulled low).

A standard CRC-8 polynomial is used: $X^8 + X^2 + X^1 + 1$

The CRC monitor test is covered by a logic BIST.

A 64-bit string is protected by CRC. The following registers are protected:

- SAFETY_FUNC_CFG
- DEV_REV
- SAFETY_PWD_THR_CFG
- SAFETY_ERR_CFG
- WD_TOKEN_FDBK
- WD_WIN2_CFG
- WD_WIN1_CFG
- SAFETY_ERR_PWM_L
- DEV_CFG2
- DEV_CFG1 (only bit number 6)

Table 5-13 lists the CRC bus structure.

Table 5-13. CRC Bus Structure

REGISTER NAME	64-BIT BUS ORDERING
SAFETY_FUNC_CFG [6:0]	[63:57]
DEV_REV [7:0]	[56:49]
SAFETY_PWD_THR_CFG [3:0]	[48:45]
SAFETY_ERR_CFG [7:0]	[44:37]
WD_TOKEN_FDBK [7:0]	[36:29]
WD_WIN2_CFG [4:0]	[28:24]
WD_WIN1_CFG [6:0]	[23:17]
SAFETY_ERR_PWM_L [7:0]	[16:9]
DEV_CFG2 [7:0]	[8:1]
DEV_CFG1 [6]	0

In the external MCU, the CRC calculation must be performed byte-wise, starting with the lowest byte of the 64-bit bus ordering value. The most significant bit is first in the bit order. The resulting CRC of one calculation is the seed value for the next calculation. The initial seed value is FFh. The CRC result of the eighth byte-wise calculation is the CRC signature value, which must be stored in the SAFETY_CFG_CRC register (see Figure 5-13).

64-Bit Bus Ordering Value:

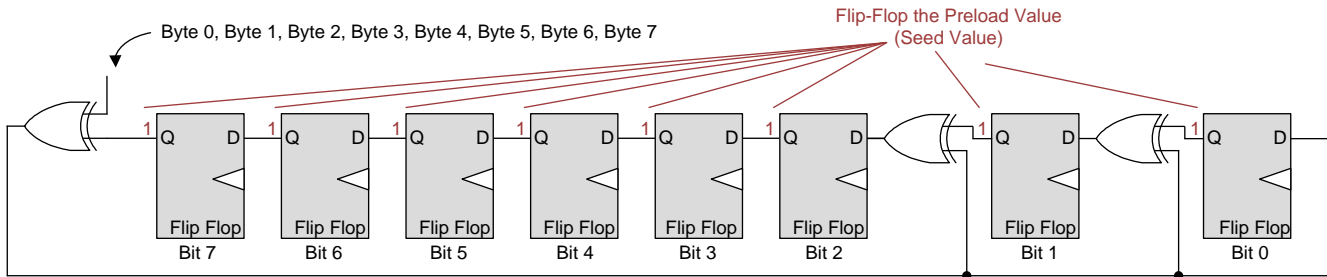
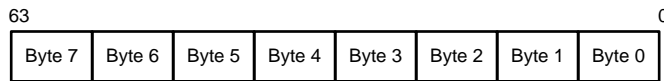

Figure 5-13. CRC Calculation Logic

Table 5-14 lists some CRC calculation examples.

Table 5-14. CRC Calculation Examples

64-BIT BUS ORDERING VALUE	CRC-8 RESULT
0000 0000 0000 0000h	DBh
FFFF FFFF FFFF FFFFh	0Ch
0A0A 0505 0A0A 0505h	D4h
0505 0A0A 0505 0A0Ah	17h
A0A0 5050 A0A0 5050h	2Bh
0A23 E000 18FE 7B80h	1Bh

In case the CRC controller detects a signature error on the configuration registers, care must be used when performing an EEPROM CRC afterwards. In case of a detected signature error in the configuration registers, the device reports an EEPROM signature error when the CFG_CRC_EN bit in the SAFETY_CHECK_CTRL register is cleared to 0 first before performing the EEPROM CRC by setting the EE_CRC_CHK bit in the SAFETY_BIST_CTRL register to 1, even when the EEPROM bits do not have an error. Therefore, when performing an EEPROM CRC after a CRC on the configuration registers, the steps must always occur in the following order:

1. Calculate CRC8 in the MCU and store it in the SAFETY_CFG_CRC register.
2. Set the CFG_CRC_EN bit in the SAFETY_CHECK_CTRL register to 1 to perform a CRC on the configuration registers.
3. After the SPI command sets the CFG_CRC_EN bit to 1 (for example, after rising edge on NCS), wait at least 2.1 μ s for the configuration register to complete the CRC.
4. Read the results of the configuration register CRC in the SAFETY_STAT_2 register, bit CFG_CRC_ERR. If continuous CRC on the configuration register must be performed, clear the CFG_CRC_EN bit in the SAFETY_CHECK_CTRL register to 0 and repeat beginning with [Step 1](#). If the CRC on the EEPROM registers must be performed, proceed to [Step 5](#).

NOTE

A correct EEPROM CRC afterwards (as described in [Step 5](#)) clears this CFG_CRC_ERR bit. Therefore, TI recommends reading out this CFG_CRC_ERR bit before performing the EEPROM CRC.

5. Set the EE_CRC_CHK bit in the SAFETY_BIST_CTRL register to 1 to perform the CRC on the EEPROM registers.
6. After the SPI command sets the EE_CRC_CHK bit to 1 (for example, after rising edge on NCS), wait at least 811 μ s for the EEPROM CRC to finish.
7. Completion of the EEPROM CRC is observed by reading the EE_CRC_CHK bit. When the EEPROM CRC is complete, this EE_CRC_CHK bit is cleared to 0.
8. Clear the CFG_CRC_EN bit in the SAFETY_CHECK_CTRL register to 0
9. Read the results of the EEPROM CRC in the SAFETY_STAT_2 register, bit EE_CRC_ERR.
10. Go back to [Step 1](#).

NOTE

Returning to [Step 1](#) is not required; returning to [Step 2](#) is also an option.

NOTE

While in the DIAGNOSTIC state, a check can be performed to confirm the CFG_CRC_ERR bit is set to 1 on a mismatch between the value stored in the SAFETY_CFG_CRC register and the value that is calculated from the configuration registers covered by the CRC8. If the CFG_CRC_EN is cleared while the CFG_CRC_ERR bit is set to 1, then the device transitions to the SAFE state, set the EE_CRC_ERR bit and clear the CFG_CRC_EN bit. To avoid this transition to the SAFE state, the CFG_CRC_ERR bit must be cleared by running the EEPROM CRC by setting the EE_CRC_CHK bit. While the EEPROM CRC is running, the EE_CRC_ERR bit is set. Assuming the EEPROM CRC was good, both the EE_CRC_ERR and CFG_CRC_ERR bits are cleared. To check if the CFG_CRC_ERR bit is 0 for a matching CRC, the matching CRC value should be stored in the SAFETY_CFG_CRC register. Then the CFG_CRC_EN bit must be cleared to 0 and set again to 1 which reruns the CRC on the configuration registers, resulting in the CFG_CRC_ERR bit being 0.

5.4.18 Enable and Reset Driver Circuit

Figure 5-14 shows the reset and enable circuit.

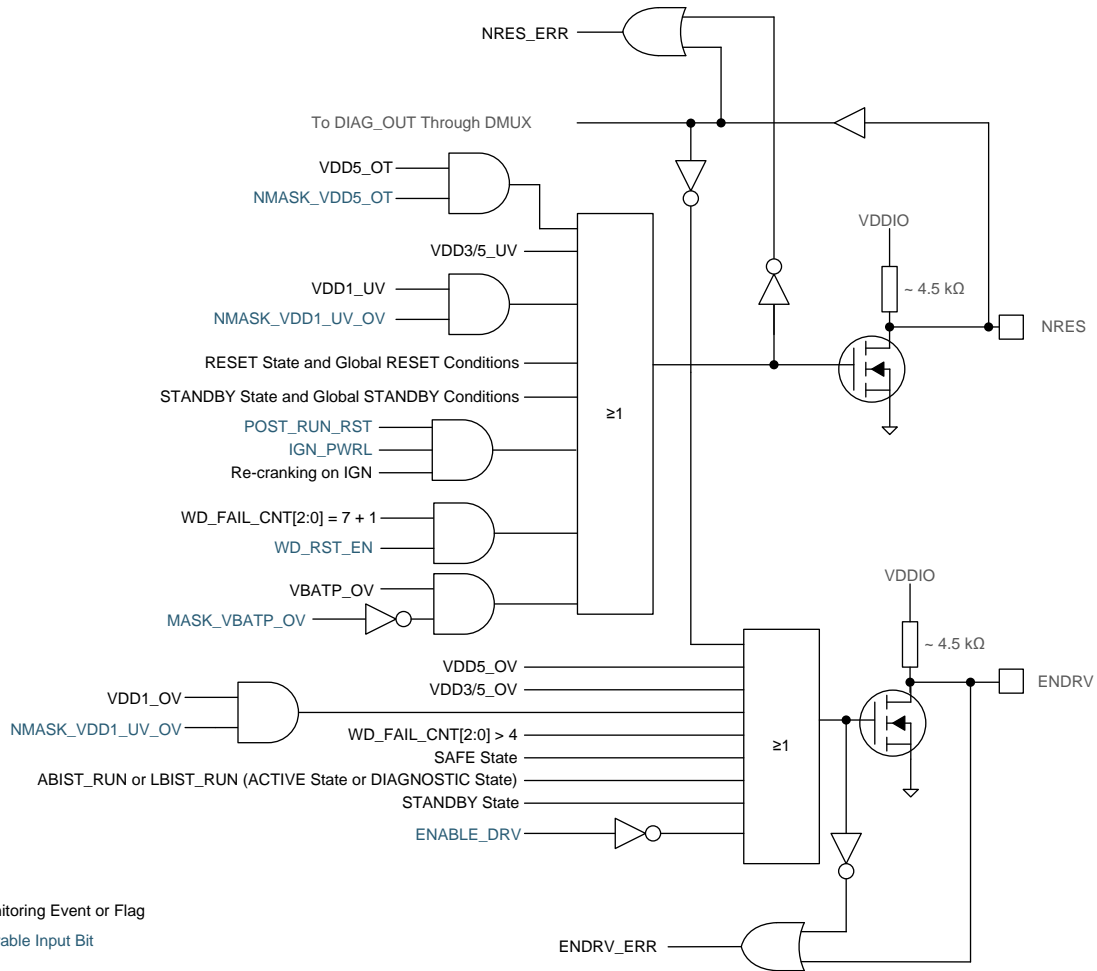

Bit Type
 Status or Monitoring Event or Flag
 User Configurable Input Bit

Figure 5-14. Reset and Enable Circuit

The ENDRV pin features a read-back circuit to compare the external ENDRV level with the internally applied ENDRV level. This feature detects any possible failure in the ENDRV pullup or pulldown components. A failure is detected by the MCU through the ENDRV_ERR bit (bit 1 in the SAFETY_STAT_4 register).

The ENDRV pin is pulled low for the ABIST duration time (approximately 300 μs) when activating the ABIST function after the ENDRV output is turned on and driven high. This is part of ENDRV diagnostics to validate all monitoring functions that disable the ENDRV output and confirm that the ENDRV output is controllable by using the ENDRV read-back path.

The NRES pin features a readback of the external NRES level. The value is read on the DIAG_OUT pin and NRES_ERR bit (bit 5 in the SAFETY_STAT_3 register)..

For both the ENDRV pin and the NRES pin, the logic read-back threshold level is typically 400 mV.

Figure 5-15 shows the timing-response diagram for the NRES and ENDRV pins to any VDDx undervoltage or overvoltage condition.

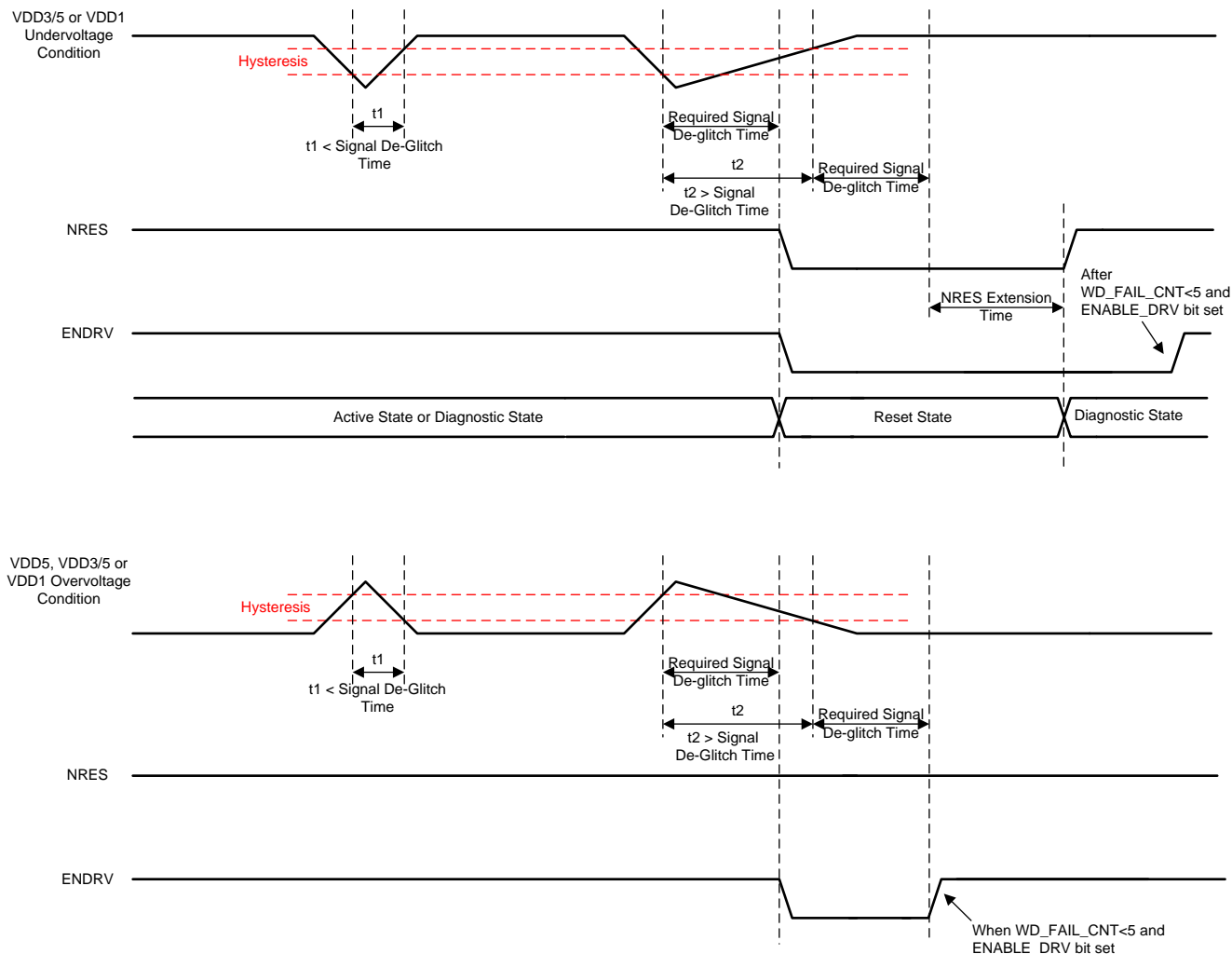

- (1) The signal deglitch time is defined for each undervoltage or overvoltage condition as given in [Section 4](#).
- (2) The NRES extension time is defined by the external resistor value as given in [Section 4](#).

Figure 5-15. Timing-Response Diagram for NRES and ENDRV Pins to any VDDx Undervoltage or Overvoltage Condition

5.4.19 Device Operating States

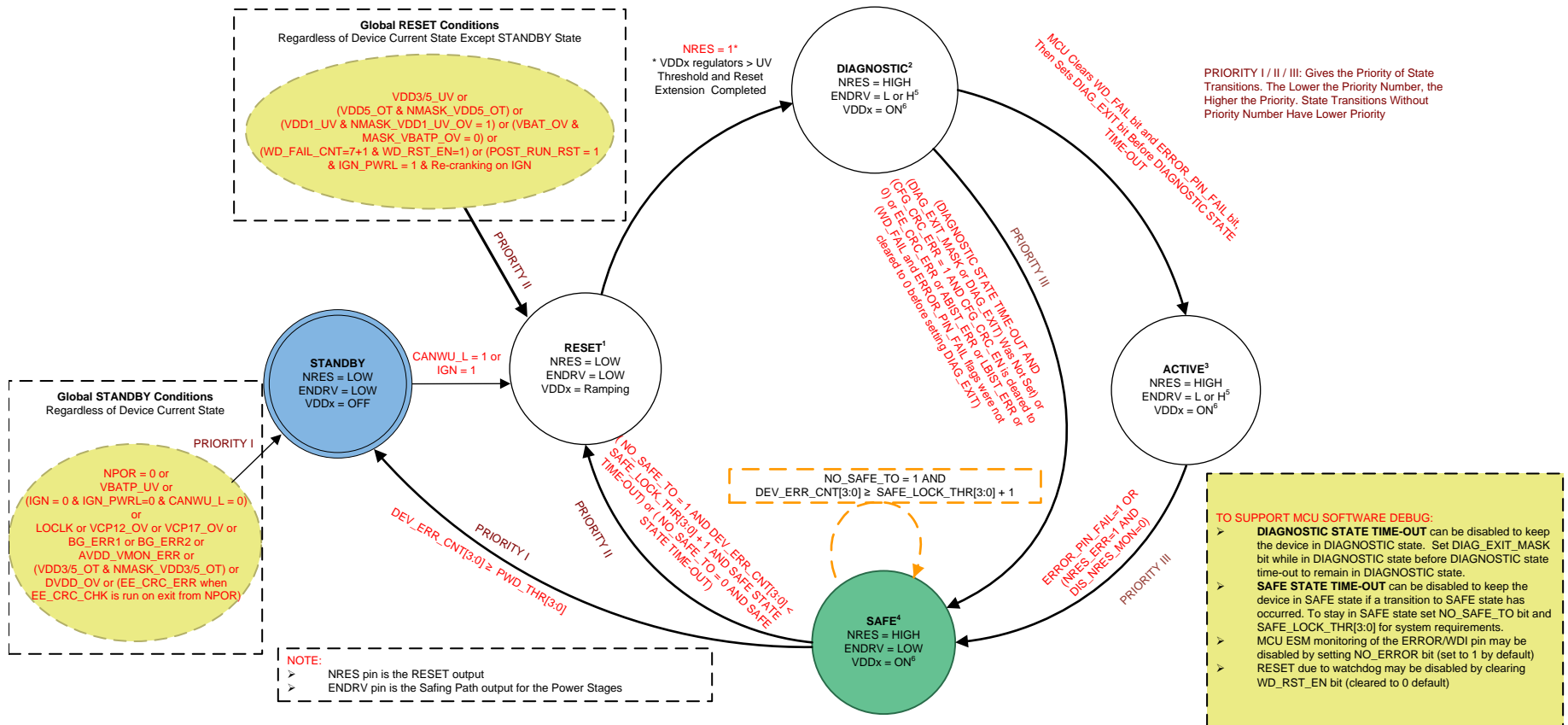

- (1) RESET State: SPI, Watchdog and MCU ESM are in reset; see Section 5.4.21 section for conditions that prevent the wake up from the STANDBY state to the RESET state.
- (2) DIAGNOSTIC State: BIST (LBIST with ABIST) is initiated on the transition into the DIAGNOSTIC state. See Section 5.4.22 for options to disable automatic BIST run, the DIAGNOSTIC state time-out and diagnostics the MCU may perform on safety functions. WD_FAIL_CNT reinitializes to 5 on transition into the DIAGNOSTIC state.
- (3) ACTIVE State: WD_FAIL_CNT reinitializes to 5 during transition into the ACTIVE state. During the ACTIVE state the MCU may perform diagnostics of some safety functions, see Section 5.4.23 for more details.
- (4) SAFE State: DEV_ERR_CNT[3:0] increments on any transition to the SAFE state. See Section 5.4.24 for details on SAFE state time-out.
- (5) The ENDRV pin level is dependent on the ENABLE_DRV bit, WD_FAIL_CNT[2:0] counter value, and VDDx_OV as shown in Figure 5-14 in the DIAGNOSTIC and ACTIVE states.
- (6) The VDD5 and VSOUT1 regulators may be enabled or disabled in the DIAGNOSTIC, ACTIVE, and SAFE states.

Figure 5-16. Device Controller State Diagram

5.4.20 STANDBY State

The STANDBY state is the default state when the device is supplied by the VBATP and VBAT_SAFING supplies. This state has the characteristics that follow:

- All regulators are disabled
- The NRES and ENDRV pins are low.
- The device transitions to the STANDBY state from any state because of the following:
 - Internal power-on reset event (NPOR = 0)
 - VBATP undervoltage event (VBATP_UV)
 - Deglitched IGN = 0 and IGN_PWRL = 0 (cleared IGN power-latch control bit) and CANWU_L = 0
 - Loss-of-clock detection (LOCLK)
 - VDD3/5 overtemperature event (VDD3/5_OT) while NMASK_VDD3/5_OT = 1
 - DVDD undervoltage event (DVDD_UV)
 - DVDD overvoltage event (DVDD_OV)
 - AVDD_VMON overvoltage or undervoltage event (AVDD_VMON_ERR)
 - VCP12 overvoltage event (VCP12_OV)
 - VCP17 overvoltage event (VCP17_OV)
 - Error with band gaps: BG_ERR1 or BG_ERR2
 - EEPROM check fails during run after exit from NPOR event (EE_CRC_ERR = 1 when EE_CRC_CHK is run on exit from NPOR)
 - The device error count (DEV_ERR_CNT[3:0]) is greater than or equal to the programmed power-down threshold, PWD_THR[3:0]

5.4.21 RESET State

The RESET state has the characteristics that follow:

- This state is entered from the STANDBY state after a wake-up request from ignition (IGN pin = high, deglitched IGN bit = 1) or CANWU pin (CANWU pin = high, deglitched and latched CANWU_L bit = 1). The following conditions would prevent the transition from the STANDBY state to the RESET state even if a wake-up request occurred:
 - BG_ERR1
 - BG_ERR2
 - VCP17_OV
 - VCP12_OV
 - AVDD_VMON_ERR
 - EE_CRC_CHK fails
- This state is entered from the SAFE state after a SAFE state time-out occurs and the DEV_ERR_CNT[3:0] counter is less than the programmed SAFE_LOCK_THR[3:0] + 1. See [Section 5.4.24](#) for details on the SAFE state time-out duration which is set by the SAFE_TO[2:0] and NO_SAFE_TO bits.
- The device transitions to the RESET state from any other state because of the following:
 - VDD3/5 undervoltage event (VDD3/5_UV)
 - VDD5 overtemperature event (VDD5_OT) when NMASK_VDD5_OT = 1
 - VDD1 undervoltage event (VDD1_UV) when NMASK_VDD1_UV_OV = 1 (not default)
 - VBATP overvoltage event (VBATP_OV) when MASK_VBATP_OV = 0 (default)
 - Watchdog reset. A watchdog reset occurs after the watchdog fail counter (WD_FAIL_CNT[2:0]) has reached a value of 7 and another bad event occurs (7+1) which sets the WD_FAIL flag when WD_RST_EN = 1 (not default)
 - POST_RUN_RST = 1 and IGN_PWRL = 1 and a re crank (LOW followed by a valid HIGH) on IGN pin
- The VDDx regulators are powered on.

- The NRES and ENDRV pins are low.
- The SPI, watchdog, and MCU ESM are in reset.

5.4.22 DIAGNOSTIC State

The DIAGNOSTIC state has the characteristics that follow:

- The DIAGNOSTIC state is entered from the RESET state after the VDDx regulators have ramped-up and the reset extension is complete
- The VDD5 (enabled by default) regulator can be disabled by the VDD5_EN bit, and the VSOUT1 regulator can be enabled (disabled by default) by the VSOUT1_EN bit.
- The NRES pin is HIGH.
- The state of the ENDRV pin is determined by the ENABLE_DRV bit, WD_FAIL_CNT[2:0] counter value, and the overvoltage monitoring for the VDDx regulators (VDDx_OV) as shown in [Figure 5-14](#).
- The watchdog and MCU error signal monitoring (ESM) functions can be configured and operated. The MCU ESM module does not cause a transition to the SAFE state from the DIAGNOSTIC state when an emulated failure on the ERROR/WDI pin is detected. This allows the MCU to run diagnostics on the MCU ESM and ERROR/WDI pin during the DIAGNOSTIC state.
- This state is where the MCU should perform all device self-tests and diagnostics (failures are induced to emulate internal failures and confirm detection).
- Upon entry of the DIAGNOSTIC state, the watchdog fail counter is reinitialized to 5.
- The BIST (LBIST with ABIST) is activated with the transition out of the RESET state into the DIAGNOSTIC including a power up event from the STANDBY state. This automatic BIST run can be disabled with the AUTO_BIST_DIS bit for cases when the RESET state was entered from the DIAGNOSTIC, ACTIVE, or SAFE state, but cannot be disabled when the RESET state was entered from the STANDBY state at power up.
- The BIST (LBIST with ABIST) is initiated on the transition to the DIAGNOSTIC state.
- During the DIAGNOSTIC state, the MCU can perform diagnostics of any safety function such as watchdog, MCU ESM, ERROR/WDI pin, DIAG_MUX pin, and CRC on registers. Ti recommends running diagnostic checks at least every power-up cycle while in the DIAGNOSTIC state.

NOTE

DIAGNOSTIC state time-out: When the DIAGNOSTIC state is entered, if the DIAG_EXIT_MASK or DIAG_EXIT bit is not set to 1 within 512 ms (typical), the DIAGNOSTIC state time-out interval expires, causing a transition to the SAFE state. This also sets both the ERROR_PIN_FAIL and WD_FAIL bits in the SAFETY_ERR_STAT register and sets the mirror bits, MCU_ERR and WD_ERR, in the SAFETY_STAT_4 register. The device error count (DEV_ERR_CNT[3:0]) is incremented. Only the DIAG_EXIT_MASK or DIAG_EXIT bit should be set in a single SPI write command to the SAFETY_CHECK_CTRL register. Setting the DIAG_EXIT bit to 1 causes a transition to the ACTIVE state. Setting the DIAG_EXIT_MASK bit to 1 causes the device to remain in the DIAGNOSTIC state (only recommended for software debug).

NOTE

DIAG_EXIT_MASK for software debug: When the DIAG_EXIT_MASK bit is set to 1 before the DIAGNOSTIC state time-out interval expires, the device stays in the DIAGNOSTIC state until the bit is cleared. The DIAGNOSTIC state time-out timer remains free running in the background, but does not cause a state transition. When the DIAGNOSTIC state time-out interval has expired, the DIAG_EXIT bit is set automatically (in addition to the DIAG_EXIT_MASK bit remaining set) and the device remains in the DIAGNOSTIC state. For a controlled transition to the ACTIVE state, TI recommends clearing the DIAG_EXIT_MASK bit and setting the DIAG_EXIT bit with a single SPI write command to the SAFETY_CHECK_CTRL register. If both the DIAG_EXIT_MASK bit and DIAG_EXIT bits are cleared at the same time, the device remains in the DIAGNOSTIC state until either the next DIAGNOSTIC state time-out interval expires causing a transition to the SAFE state or if the DIAG_EXIT bit is set to 1, prior to the DIAGNOSTIC state time-out, transitioning the device to ACTIVE state.

NOTE

In the DIAGNOSTIC state the following considerations must be considered if a manual run of the LBIST is initiated by setting the LBIST_EN bit to 1. Setting the LBIST_EN bit to 1 clears the DIAG_EXIT_MASK bit to 0. If the DIAG_EXIT_MASK bit is being used to hold the device in the DIAGNOSTIC state for software debug, it must be set again to 1 after LBIST completion to stay in the DIAGNOSTIC state. The DIAGNOSTIC state time-out counter stops only during the running of LBIST. After the LBIST completes, the time-out counter continues from the last value. For a transition from the DIAGNOSTIC state to the ACTIVE state, the DIAG_EXIT bit must be set to 1.

5.4.23 ACTIVE State

The ACTIVE state has the characteristics that follow:

- The device enters from the DIAGNOSTIC state after the MCU sets the DIAG_EXIT bit after clearing the ERROR_PIN_FAIL and WD_FAIL bits.
-

NOTE

While in the DIAGNOSTIC state, the MCU must clear by writing a 0 to the ERROR_PIN_FAIL bit and the WD_FAIL bit in the SAFETY_ERR_STAT register before setting the DIAG_EXIT bit. Clearing these bits also clears their mirror bits, MCU_ERR and WD_ERR. Otherwise, a transition to the SAFE state occurs.

- The NRES pin is high.
- The state of the ENDRV pin is determined by the ENABLE_DRV bit, WD_FAIL_CNT[2:0] counter value, and the overvoltage monitoring for the VDDx regulators (VDDx_OV) as shown in [Figure 5-14](#);
- The VDDx regulators are on, the VDD5 regulator can be enabled or disabled through the VDD5_EN bit. The VSOUT1 regulator can be enabled or disabled through the VSOUT1_EN bit.
- The WD_FAIL_CNT[2:0] counter reinitializes to 5 during a transition from the DIAGNOSTIC state to the ACTIVE state.
- The watchdog and MCU ESM monitoring functions are operated as configured but cannot be reconfigured.
- During the ACTIVE state, the MCU can perform diagnostics of some safety function such as watchdog, DIAG_MUX pin, ABIST (approximately 300 μ s, ENDRV pin will be low), LBIST (approximately 21 ms, ENDRV pin will be low), and CRC on registers depending on the system safety requirements.

NOTE

In the ACTIVE state the following considerations must be considered if a manual run of the LBIST is initiated by setting the LBIST_EN bit to 1. The LBIST should only be run in the ACTIVE state if the system-safety timing requirements can allow the total 21-ms BIST time and the ENDRV pin being low for the 21-ms.

See [Section 5.4.7](#) for additional system considerations if LBIST is run in the ACTIVE state.

5.4.24 SAFE State

The SAFE state has the characteristics that follow:

- The SAFE state is entered from:
 - The ACTIVE state by:
 - An error in the signal on the ERROR/WDI pin detected by the MCU ESM while enabled.. This transition is because of an error in the MCU and sets the ERROR_PIN_FAIL flag.
 - A detected read-back error on the NRES pin which sets the NRES_ERR flag while DIS_NRES_MON is cleared to 0 (1 in default state).
 - The DIAGNOSTIC state by:
 - After a DIAGNOSTIC state time-out event happens before the DIAG_EXIT_MASK bit is set to 1, keeping the device in the DIAGNOSTIC state or before the DIAG_EXIT bit is set to 1 transitioning the device to ACTIVE.
 - CFG_CRC_ERR = 1 AND CFG_CRC_EN is cleared to 0
 - An EE_CRC_ERR is detected in the DIAGNOSTIC state.
 - An ABIST_ERR or LBIST_ERR is detected in the DIAGNOSTIC state.
 - The WD_FAIL and ERROR_PIN_FAIL flags were not cleared to 0 before setting the DIAG_EXIT bit while exiting the DIAGNOSTIC state.
- Every transition to the SAFE state increments the device error count, DEV_ERR_CNT[3:0].
- The device stays in the SAFE state when the NO_SAFE_TO bit is set to 1 (default state) and DEV_ERR_CNT[3:0] = SAFE_LOCK_THR[3:0] + 1. This allows for programming the MCU without causing a reset and transition to the RESET state because of the SAFE state time-out.
- The NRES pin is high.
- The ENDRV pin is low.
- The VDDx regulators are on, the VDD5 regulator can be enabled or disabled with the VDD5_EN bit. The VSOUT1 regulator can be enabled or disabled with the VSOUT1_EN bit.

NOTE

The SAFE state time-out and device configuration settings are used by the device state machine to determine what the device does after a transition to the SAFE state. Depending on the NO_SAFE_TO, PWD_THR[3:0], SAFE_LOCK_THR[3:0], and DEV_ERR_CNT[3:0] bits, the device stays locked in the SAFE state, transitions to the RESET state, or transitions to STANDBY state. The SAFE state time-out duration is programmable through SAFE_TO[2:0].

NO_SAFE_TO = 1 (Default)

- While $DEV_ERR_CNT[3:0] < (SAFE_LOCK_THR[3:0] + 1)$ the time delay for the SAFE state time-out is programmed by the SAFE_TO[2:0] bit. The delay is calculated by $[(SAFE_TO[2:0] \times 2) + 1] \times 22$ ms.
- The device remains locked in the SAFE state when $DEV_ERR_CNT[3:0] \geq SAFE_LOCK_THR[3:0] + 1$.

NO_SAFE_TO = 0

- While $DEV_ERR_CNT[3:0] < (SAFE_LOCK_THR[3:0] + 1)$ the time delay for the SAFE state time-out is programmed by the SAFE_TO[2:0] bits. The delay is calculated by $[(SAFE_TO[2:0] \times 2) + 1] \times 22$ ms.
- When $DEV_ERR_CNT[3:0] \geq SAFE_LOCK_THR[3:0] + 1$, the SAFE state time-out duration changes and the device transitions to the RESET state after approximately 680 ms.

If the PWD_THR[3:0] threshold is used, the device transitions from the SAFE state to the STANDBY state when $DEV_ERR_CNT[3:0] \geq PWD_THR[3:0]$. This transition has higher priority (PRIORITY I) than the path from the SAFE state to the RESET state (PRIORITY II) so if $PWD_THR[3:0] = SAFE_LOCK_THR[3:0] + 1$ the device transitions to the STANDBY state not the RESET state.

5.4.25 State Transition Priorities

For all global or possible double-state transitions, the following priorities hold true:

1. Priority I: all conditions for STANDBY state transition
2. Priority II: all conditions for RESET state transition
3. Priority III: all conditions for SAFE state transition

All other state transitions have a lower priority compared to any of the state transitions listed with priority numbers.

5.4.26 Power on Reset (NPOR)

The device goes through a power on reset (NPOR) which reinitializes all registers. The events that cause an NPOR are:

- Analog power on reset:
 - Loss-of-clock detection (LOCLK)
 - AVDD_VMON overvoltage or undervoltage event (AVDD_VMON_ERR)
 - DVDD undervoltage event (DVDD_UV)
 - DVDD overvoltage event (DVDD_OV)

- Digital power on reset. These errors can cause a NPOR. If the detected fault duration is less than 6 ms, an NPOR may not occur. When the CANWU or IGN state is kept high, the device transitions to the RESET state because of the wake-up request. The registers on the post-BIST reinitialization list are reinitialized after BIST runs on the transition from the RESET state to the DIAGNOSTIC state (unless AUTO_BIST_DIS = 1, not default).
 - VBATP undervoltage event (VBATP_UV)
 - VDD3/5 overtemperature event (VDD3/5_OT) while NMASK_VDD3/5_OT = 1
 - AVDD undervoltage event (AVDD_UV)
 - Error with the device VMON trim settings (VMON_TRIM_ERROR)
 - Error with band gaps: BG_ERR1 or BG_ERR2
 - VCP12 overvoltage event (VCP12_OV)
 - VCP17 overvoltage event (VCP17_OV)

5.5 Register Maps

5.5.1 Serial Peripheral Interface (SPI)

The primary communication between the device and the external the MCU is through a SPI bus which provides full-duplex communications in a master-slave configuration. The external MCU is always a SPI master, which sends command requests on the SDI pin and receives device responses on the SDO pin. The TPS65381A-Q1 device is always a SPI slave device, which receives command requests and sends responses (status, measured values) to the external MCU over the SDO line.

- The SPI is a 4-pin interface.
 - NCS—SPI chip select (active-low)
 - SCLK—SPI clock
 - SDI—SPI slave-in and master-out (SIMO)
 - SDO—SPI slave-out and master-in (SOMI, three-state output)
- The SPI frame size is 16 bits.
- Speed is up to 6 Mbit/s.
- Commands and data are shifted MSB first, LSB last.
- The SDI line is sampled on the falling edge of SCLK.
- The SDO line is shifted out on the rising edge of SCLK.

The SPI communication starts with the NCS falling edge, and ends with the NCS rising edge. The NCS high level keeps the SPI slave interface in the reset state, and the SDO output is in the tri-state.

5.5.1.1 SPI Command Transfer Phase

Table 5-15 shows the transfer frame format of SPI data during a command (write or read command)..

Table 5-15. SPI Command Transfer Phase

BIT	D7	D6	D5	D4	D3	D2	D1	D0
FUNCTION	CMD6	CMD5	CMD4	CMD3	CMD2	CMD1	CMD0	PARITY

CMD[6:0] Register write (WR) or read (RD) command

PARITY Parity bit for 7-bit command field

The SPI does not support back-to-back SPI frame operation. After each SPI command or read access, the NCS pin must transition from low-to-high before the next SPI transfer can start. The minimum time (t_{hlcs}) between two SPI commands during which the NCS pin must remain high is 788 ns.

5.5.1.2 SPI Data-Transfer Phase

Table 5-16 shows the transfer frame format of SPI data during a write access.

Table 5-16. SPI Data-Transfer Phase

BIT	D7	D6	D5	D4	D3	D2	D1	D0
FUNCTION	DATA7	DATA6	DATA5	DATA4	DATA3	DATA2	DATA1	DATA0

DATA[7:0] Data value for write access (8-bit)

The SPI does not support back-to-back SPI frame operation. After each SPI transfer, the NCS pin must go from low to high before the next SPI transfer can start. The minimum time (t_{hics}) between two SPI commands during which the NCS pin must remain high is 788 ns.

5.5.1.3 Device Status Flag Byte Response

Table 5-17 shows the response frame format of the SPI data status during a command (write or read access).

Table 5-17. Device Status Flag Byte Response

BIT	R7	R6	R5	R4	R3	R2	R1	R0
FUNCTION	STAT[7]	STAT[6]	STAT[5]	STAT[4]	STAT[3]	STAT[2]	STAT[1]	STAT[0]

STAT[7] 1

STAT[6] 0

STAT[5] 1

STAT[4] 0

STAT[3] SPI WR access (during previous SPI frame-command phase)

STAT[2] SPI SDO error (during previous SPI frame)

STAT[1] 0

STAT[0] SPI errors including truncated SPI frames, SPI transfers with more than 16 bits, SPI transfers with undefined commands or SPI transfers with incorrect command parity (during previous SPI frame)

The status bits sent during the current SPI command are reflecting the status of the previous SPI command.

NOTE

If a reset to the MCU is asserted during a SPI frame transfer (causing a truncated SPI frame), these SPI error status bits are not cleared, but maintain the status according to the truncated previous SPI frame until a SPI read access.

NOTE

The SPI SDO error bit, STAT[2], may be inadvertently set when the NCS pin is high, the SDO pin is high, and a falling edge occurs on the SPICLK pin. This combination occurs most often when the device is used in a SPI bus with multiple SPI slaves. If all three of these conditions are met, the SDO error flag is set to 1 in the second SPI flag byte response of the following SPI communication with the TPS65381A-Q1. The application software should mask out the SDO error flag if the device is used under these conditions. If a SPI SDO error is detected, the device accepts the SPI transfer because the detected error is on the output not the input for the SPI.

NOTE

For additional diagnostic coverage for SPI write transfers, the system software could perform a read of the register written and compare the returned value to the value that is expected after the write. Be aware some bits in some registers are not writable.

5.5.1.4 Device SPI Data Response

Table 5-18 shows the response frame format of the SPI device data during a write or read access.

Table 5-18. Device SPI Data Response

BIT	R7	R6	R5	R4	R3	R2	R1	R0
FUNCTION	R7	R6	R5	R4	R3	R2	R1	R0

R[7:0] Internal register value. All unused bits are cleared to 0.

5.5.1.5 SPI Frame Overview

Figure 5-17 shows an overview of a complete 16-bit SPI Frame:

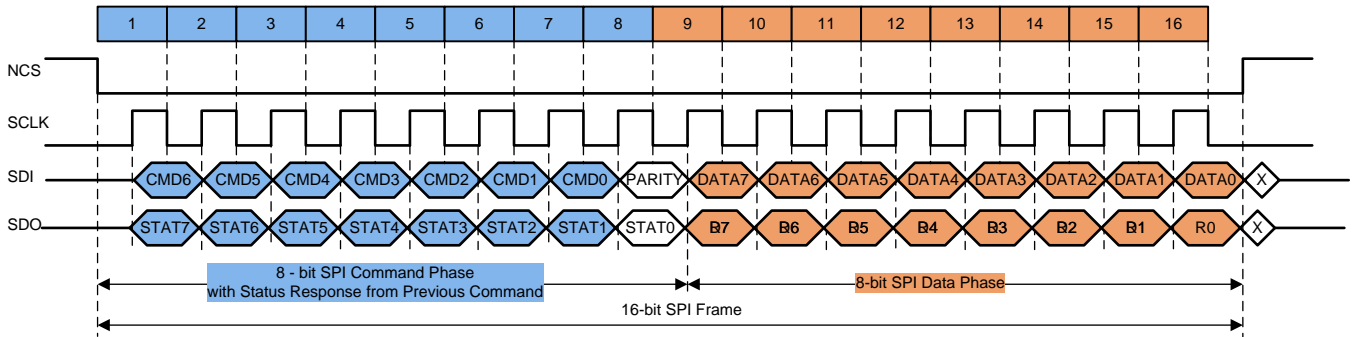

The SPI master (MCU) and SPI slave (TPS65381A-Q1) sample receive data on the falling SCLK edge and transmit data on the rising SCLK edge.

Figure 5-17. 16-Bit SPI Frame

5.5.2 SPI Register Write Access Lock (SW_LOCK command)

The SW_LOCK command protects the SPI registers against write update access through MCU control. When the SW_LOCK command with data AAh is sent to the device, the listed registers are locked from updates through a write access. To unlock the SPI registers, the SW_UNLOCK command with data 55h is sent to the device.

NOTE

The SW_LOCK command is in addition to the automatic locking of specific SPI registers against write update access except while the device is in DIAGNOSTIC state. Please see the SPI Command Table and the register descriptions to determine if SW_LOCK and automatic locking except in DIAGNOSTIC state apply to specific write access registers.

5.5.3 SPI Registers (SPI Mapped Response)

The following sections list the SPI registers. For each SPI register, the bit names are given along with the initialized values (values after internal logic reset).

The values are initialized after each wake-up from the STANDBY state or after any other power-on reset (NPOR) event.

After a LBIST run is complete, including the LBIST run on the transition out of RESET state, the following functions and registers re-initialize:

- DEV_STAT
- SAFETY_STAT_2
- SAFETY_STAT_4
- SAFETY_STAT_5 (but FSM[2:0] immediately updates to reflect the current device state)
- WD_TOKEN_VALUE

- WD_STATUS
- SAFETY_CHECK_CTRL
- DIAG_CFG_CTRL
- DIAG_MUX_SEL

The initialized value of the reserved bits (RSV) is indicated, however some of these bits are used for internal device operation and the application software should mask them as they may not remain at their initialized value.

The following sections also list an explanation of each bit function.

Table 5-19. SPI Command Table

8-BIT HEX COMMAND CODE (WITH PARITY)	7-BIT HEX COMMAND CODE (WITHOUT PARITY)	7-BIT BINARY COMMAND CODE (WITHOUT PARITY)	PARITY	WR SW LOCK PROTECT	REGISTER COMMAND NAME ⁽¹⁾
BDh	5Eh	1011 110b	1	N/A	SW_LOCK with data AAh (to lock SPI WR access to listed registers)
BBh	5Dh	1011 101b	1	N/A	SW_UNLOCK with data 55h (to unlock SPI WR access to listed registers)
06h	03h	0000 011b	0	N/A	RD_DEV_ID
0Ch	06h	0000 110b	0	N/A	RD_DEV_REV
B7h	5Bh	1011 011b	1	YES	WR_DEV_CFG1 (SPI WR update can occur only in the DIAGNOSTIC state)
AFh	57h	1010 111b	1	N/A	RD_DEV_CFG1
95h	4Ah	1001 010b	1	YES	WR_DEV_CFG2 (SPI WR update can occur only in the DIAGNOSTIC state)
48h	24h	0100 100b	0	N/A	RD_DEV_CFG2
7Dh	3Eh	0111 110b	1	NO	WR_CAN_STBY (only valid with data 00h)
24h	12h	0010 010b	0	N/A	RD_SAFETY_STAT_1
C5h	62h	1100 010b	1	N/A	RD_SAFETY_STAT_2
A3h	51h	1010 001b	1	N/A	RD_SAFETY_STAT_3
A5h	52h	1010 010b	1	N/A	RD_SAFETY_STAT_4
C0h	60h	1100 000b	0	N/A	RD_SAFETY_STAT_5
30h	18h	0011 000b	0	N/A	RD_SAFETY_ERR_CFG
DBh	6Dh	1101 101b	1	YES	WR_SAFETY_ERR_CFG (SPI WR update can occur only in the DIAGNOSTIC state)
A9h	54h	1010 100b	1	YES	WR_SAFETY_ERR_STAT (SPI WR update can occur only in the DIAGNOSTIC state)
AAh	55h	1010 101b	0	N/A	RD_SAFETY_ERR_STAT
39h	1Ch	0011 100b	1	N/A	RD_SAFETY_PWD_THR_CFG
99h	4Ch	1001 100b	1	YES	WR_SAFETY_PWD_THR_CFG (SPI WR update can occur only in the DIAGNOSTIC state)
44h	22h	0100 010b	0	N/A	RD_SAFETY_CHECK_CTRL
93h	49h	1001 001b	1	NO	WR_SAFETY_CHECK_CTRL
3Ch	1Eh	0011 110b	0	N/A	RD_SAFETY_BIST_CTRL
9Fh	4Fh	1001 111b	1	YES	WR_SAFETY_BIST_CTRL
2Eh	17h	0010 111b	0	N/A	RD_WD_WIN1_CFG
EDh	76h	1110 110b	1	YES	WR_WD_WIN1_CFG (SPI WR update can occur only in the DIAGNOSTIC state)
05h	02h	0000 010b	1	N/A	RD_WD_WIN2_CFG
09h	04h	0000 100b	1	YES	WR_WD_WIN2_CFG (SPI WR update can occur only in the DIAGNOSTIC state)

(1) All commands have even parity.

Table 5-19. SPI Command Table (continued)

8-BIT HEX COMMAND CODE (WITH PARITY)	7-BIT HEX COMMAND CODE (WITHOUT PARITY)	7-BIT BINARY COMMAND CODE (WITHOUT PARITY)	PARITY	WR SW LOCK PROTECT	REGISTER COMMAND NAME ⁽¹⁾
36h	1Bh	0011 011b	0	N/A	RD_WD_TOKEN_VALUE
4Eh	27h	0100 111b	0	N/A	RD_WD_STATUS
E1h	70h	1110 000b	1	NO	WR_WD_ANSWER
11h	08h	0001 000b	1	N/A	RD_DEV_STAT
12h	09h	0001 001b	0	N/A	RD_VMON_STAT_1
A6h	53h	1010 011b	0	N/A	RD_VMON_STAT_2
56h	2Bh	0101 011b	0	N/A	RD_SENS_CTRL
7Bh	3Dh	0111 101b	1	N/A	WR_SENS_CTRL
3Ah	1Dh	0011 101b	0	N/A	RD_SAFETY_FUNC_CFG
35h	1Ah	0011 010b	1	YES	WR_SAFETY_FUNC_CFG (SPI WR update can occur only in the DIAGNOSTIC state)
5Ah	2Dh	0101 101b	0	N/A	RD_SAFETY_CFG_CRC
63h	31h	0110 001b	1	YES	WR_SAFETY_CFG_CRC (SPI WR update can occur only in the DIAGNOSTIC state)
DDh	6Eh	1101 110b	1	N/A	RD_DIAG_CFG_CTRL
CCh	66h	1100 110b	0	NO	WR_DIAG_CFG_CTRL
ACh	56h	1010 110b	0	N/A	RD_DIAG_MUX_SEL
C9h	64h	1100 100b	1	NO	WR_DIAG_MUX_SEL
D7h	6Bh	1101 011b	1	N/A	RD_SAFETY_ERR_PWM_H
D8h	6Ch	1101 100b	0	YES	WR_SAFETY_ERR_PWM_H (SPI WR update can occur only in the DIAGNOSTIC state)
59h	2Ch	0101 100b	1	N/A	RD_SAFETY_ERR_PWM_L
7Eh	3Fh	0111 111b	0	YES	WR_SAFETY_ERR_PWM_L (SPI WR update can occur only in the DIAGNOSTIC state)
78h	3Ch	0111 100b	0	N/A	RD_WD_TOKEN_FDBK
77h	3Bh	0111 011b	1	YES	WR_WD_TOKEN_FDBK (SPI WR update can occur only in the DIAGNOSTIC state)

5.5.3.1 Device Revision and ID

5.5.3.1.1 DEV_REV Register

Initialization source: NPOR

Controller access: Read only (RD_DEV_REV)

Figure 5-18. DEV_REV Register

D7	D6	D5	D4	D3	D2	D1	D0
REV[7]	REV[6]	REV[5]	REV[4]	REV[3]	REV[2]	REV[1]	REV[0]
0b	0b	1b	1b	0b	0b	0b	0b

- D[7:0]** **REV[7:0]:** Device Revision
- REV[3:0]: Device minor revision
 - REV[7:4]: Device major revision

5.5.3.1.2 DEV_ID Register

Initialization source: NPOR

Controller access: Read only (RD_DEV_ID)

Figure 5-19. DEV_ID Register

D7	D6	D5	D4	D3	D2	D1	D0
ID[7]	ID[6]	ID[5]	ID[4]	ID[3]	ID[2]	ID[1]	ID[0]
0b	0b	0b	0b	0b	0b	0b	1b

D[7:0] ID[7:0]: Device ID

5.5.3.2 Device Status

5.5.3.2.1 DEV_STAT Register

Initialization source: NPOR, post LBIST reinitialization

Controller access: Read only (RD_DEV_STAT)

Figure 5-20. DEV_STAT Register

D7	D6	D5	D4	D3	D2	D1	D0
RSV	RSV	RSV	RSV	RSV	RSV	CANWU_L	IGN
0b	0b	0b	0b	0b	0b	X	X

D[7:2] RSV

D[1] **CANWU_L:** Latched CAN wake-up event

- The initialized value depends on whether a device wake-up event occurs through the CANWU or IGN pin.
- This bit clears to 0 when a device wake-up occurs through a CANWU, only a WR_CAN_STBY command, or any other global STANDBY condition

D[0] **IGN:** Deglitched IGN pin (7.5-ms to 22-ms deglitch time)

- The initialized value depends on whether a device wake-up event occurs through the CANWU or IGN pin. This bit follows the deglitched IGN signal, and therefore is only cleared to 0 when the deglitched IGN is low or by any other global STANDBY condition.

5.5.3.3 Device Configuration

5.5.3.3.1 DEV_CFG1 Register

Initialization source: NPOR

Controller access: Read (RD_DEV_CFG1)

Write (WR_DEV_CFG1). Write update can only occur in the DIAGNOSTIC state. Write access locked through SW_LOCK command.

Figure 5-21. DEV_CFG1 Register

D7	D6	D5	D4	D3	D2	D1	D0
VDD_3_5_SEL	NMASK_VDD1_UV_OV	RSV	RSV	RSV	RSV	RSV	RSV
X	0b	0b	0b	0b	0b	0b	0b

- D[7] VDD_3_5_SEL:** Status bit of VDD3/VDD5 selection at power up
- SEL_VDD3/5 input pin is sampled and latched at power up
 - 0b = 5-V setting (SEL_VDD3/5 pin to ground)
 - 1b = 3.3-V setting (SEL_VDD3/5 pin not connected)
 - Value in the RESET state depends on state of SEL_VDD3/5 pin at first power up
 - This bit is read only

Note: This bit is the same as the SAFETY_FUNC_CFG bit, D0)

- D[6] NMASK_VDD1_UV_OV**
- Cleared to 0 by default:
 - Masked VDD1_OV does not impact the ENDRV pin state
 - Masked VDD1_UV does not impact the NRES pin state
 - The default setting (0, masked) can be used in case the VDD1 regulator is not used in an application and the external power FET is not populated.

Note: If the VDD1 regulator is used in an application, TI recommends setting this bit to 1 when the device is in the DIAGNOSTIC state after the first start-up or power-up event.

Note: Even if this bit is set to 1, but the VDD1_SENSE pin is externally floating, the pin is pulled up. The pullup condition is detected but the VDD1_OV condition is masked and the ENDRV pin state is not impacted.

D[5:0] RSV

5.5.3.3.2 DEV_CFG2 Register

Initialization source: NPOR

Controller access: Read (RD_DEV_CFG2)

Write (WR_DEV_CFG2). Write update can only occur in the DIAGNOSTIC state. Write access locked through SW_LOCK command.

Figure 5-22. DEV_CFG2 Register

D7	D6	D5	D4	D3	D2	D1	D0
NMASK_VDD3/5_OT	NMASK_VDD5_OT	MASK_VBATP_OV	POST_RUN_RST	RSV	RSV	RSV	RSV
1b	1b	0b	0b	0b	0b	0b	0b

D[7] NMASK_VDD3/5_OT

- When set to 1 (default), an overtemperature event on the VDD3/5 or VDD6 regulator disables the VDD3/5 regulator and the device goes to the STANDBY state. The VDD3/5_OT flag sets in the SAFETY_STAT_1 register while an overtemperature event is detected.
- When cleared to 0, an overtemperature event on the VDD3/5 or VDD6 regulator disables the VDD3/5 regulator. When the VDD3/5 regulator reaches the UV level, the device goes to the RESET state. The VDD3/5_OT flag is still set in the SAFETY_STAT_1 register while an overtemperature event is detected.

D[6] NMASK_VDD5_OT

- When set to 1 (default), an overtemperature event on the VDD5 regulator disables the VDD5 regulator and the device goes to the RESET state. The VDD5_OT flag is set in the SAFETY_STAT_1 register while an overtemperature event is detected.
- When cleared to 0 the VDD5 overtemperature shutdown is disabled and the VDD5 regulator remains enabled. The VDD5_OT flag is still set in the SAFETY_STAT_1 register while an overtemperature event is detected.

D[5] MASK_VBATP_OV

- Cleared to 0 by default.
- When set to 1, the VBATP_OV bit is masked from the RESET condition.

D[4] POST_RUN_RST:

- Cleared to 0 per default.
- When set to 1, while using the IGN_PWRL function, a recracking on the IGN pin causes the device to go to the RESET state.

D[3:0] RSV (bits are readable and writable in the DIAGNOSTIC state with no impact to device state or the ENDRV and NRES output)

5.5.4 Device Safety Status and Control Registers

5.5.4.1 VMON_STAT_1 Register

Initialization source: NPOR

Controller access: Read only (RD_VMON_STAT_1)

Figure 5-23. VMON_STAT_1 Register

D7	D6	D5	D4	D3	D2	D1	D0
VBATP_OV	VBATP_UV	VCP17_OV	VCP12_OV	VCP12_UV	AVDD_VMON_ERR	BG_ERR2	BG_ERR1
0b	0b	0b	0b	0b	0b	0b	0b

- D[7] VBATP_OV:** VBATP overvoltage status bit
- Set to 1 when a VBATP overvoltage condition is detected
 - Cleared to 0 if an overvoltage condition is no longer present
- D[6] VBATP_UV:** VBATP undervoltage status bit
- Set to 1 when a VBATP undervoltage condition is detected
 - Cleared to 0 if an undervoltage condition is no longer present
- D[5] VCP17_OV:** VCP17 overvoltage status bit
- Set to 1 when a VCP17 overvoltage condition is detected
 - Cleared to 0 if an overvoltage condition is no longer present
- D[4] VCP12_OV:** VCP12 overvoltage status bit
- Set to 1 when a VCP12 overvoltage condition is detected
 - Cleared to 0 if an overvoltage condition is no longer present
- D[3] VCP12_UV:** VCP12 undervoltage status bit
- Set to 1 when a VCP12 undervoltage condition is detected
 - Cleared to 0 if an undervoltage condition is no longer present
- D[2] AVDD_VMON_ERR:** voltage-monitor power-supply power-good status
- Set to 1 when voltage-monitor power supply is not OK.
 - Cleared to 0 if an error condition is no longer present
- D[1] BG_ERR2:** Reference band-gap 2 error
- Set to 1 when the voltage monitor is less than the main band gap
 - Cleared to 0 if an error condition is no longer present
- D[0] BG_ERR1:** Reference band-gap 1 error
- Set to 1 when the voltage monitor is greater than the main band gap
 - Cleared to 0 if an error condition is no longer present

5.5.4.2 VMON_STAT_2 Register

Initialization source: NPOR

Controller access: Read (RD_VMON_STAT_2)

Figure 5-24. VMON_STAT_2 Register

D7	D6	D5	D4	D3	D2	D1	D0
VDD6_OV	VDD6_UV	VDD5_OV	VDD5_UV	VDD3/5_OV	VDD3/5_UV	VDD1_OV	VDD1_UV
0b	0b	0b	0b	0b	0b	0b	0b

D[7] VDD6_OV: VDD6 overvoltage status bit

- Set to 1 when a VDD6 overvoltage condition is detected
- Cleared to 0 if an overvoltage condition is no longer present

D[6] VDD6_UV: VDD6 undervoltage status bit

- Set to 1 when a VDD6 undervoltage condition is detected
- Cleared to 0 if an undervoltage condition is no longer present

D[5] VDD5_OV: VDD5 overvoltage status bit

- Set to 1 when a VDD5 overvoltage condition is detected
- Cleared to 0 if an overvoltage condition is no longer present

D[4] VDD5_UV: VDD5 undervoltage status bit

- Set to 1 when a VDD5 undervoltage condition is detected.
- Cleared to 0 if an undervoltage condition is no longer present

Note: This status bit reflects the undervoltage status even if the VDD5_EN bit in the SENS_CTRL register has been cleared to 0. If the VDD5 regulator is disabled, when the VDD5 regulator discharges and an undervoltage condition is detected, the VDD5_UV bit is set to 1.

D[3] VDD3/5_OV: VDD3/5 overvoltage status bit

- Set to 1 when a VDD3/5 overvoltage condition is detected
- Cleared to 0 if an overvoltage condition is no longer present

D[2] VDD3/5_UV: VDD3/5 undervoltage status bit

- Set to 1 when a VDD3/5 undervoltage condition is detected
- Cleared to 0 if an undervoltage condition is no longer present

D[1] VDD1_OV: VDD1 overvoltage status bit

- Set to 1 when a VDD1 overvoltage condition is detected
- Cleared to 0 if an overvoltage condition is no longer present

D[0] VDD1_UV: VDD1 undervoltage status bit

- Set to 1 when a VDD1 undervoltage condition is detected
- Cleared to 0 if an undervoltage condition is no longer present

5.5.4.3 SAFETY_STAT_1 Register

Initialization source: NPOR

Controller access: Read (RD_SAFETY_STAT_1)

Figure 5-25. SAFETY_STAT_1 Register

D7	D6	D5	D4	D3	D2	D1	D0
VDD5_ILIM	VDD3/5_ILIM	VSOUT1_UV	VSOUT1_OV	RSV	VSOUT1_OT	VDD5_OT	VDD_3_5_OT
0b	0b	0b	0b	0b	0b	0b	0b

D[7] VDD5_ILIM: VDD5 current-limit status bit

- Set to 1 when a VDD5 current-limit condition is exceeded
- Cleared to 0 if a current-limit condition is no longer present

Note: This status bit is valid only when the VDD5_EN bit in SENS_CTRL register is set to 1. When the VDD5_EN bit is cleared to 0, this bit will be 1.

D[6] VDD3/5_ILIM: VDD3 current-limit status bit

- Set to 1 when a VDD3 current-limit condition is exceeded
- Cleared to 0 if a current-limit condition is no longer present

D[5] VSOUT1_UV: Sensor-supply undervoltage status bit

- Set to 1 when a VSOUT1 undervoltage condition is detected
- Cleared to 0 if an undervoltage condition is no longer present

D[4] VSOUT1_OV: Sensor-supply overvoltage status bit

- Set to 1 when a VSOUT1 overvoltage condition is detected
- Cleared to 0 if an overvoltage condition is no longer present

D[3] RSV

D[2] VSOUT1_OT: Sensor-supply overtemperature status bit

- Set to 1 when the VSOUT1 overtemperature condition is exceeded. This bit keeps the VSOUT1 regulator disabled as long as this bit is set.
- Cleared to 0 if an overtemperature condition is no longer present

D[1] VDD5_OT: VDD5 overtemperature status bit

- Set to 1 when the VDD5 overtemperature condition is exceeded. When the NMASK_VDD5_OT bit is set 1, an overtemperature event disables the VDD5 regulator and clears the VDD5_EN bit to 0 (SENS_CTRL register). When the NMASK_VDD5_OT bit is 0, an overtemperature event sets the VDD5_OT bit to 1 but no other device action is taken.
- Cleared to 0 if an overtemperature condition is no longer present

D[0] VDD_3_5_OT: VDD3/5 overtemperature status bit

- Set to 1 when the VDD3/5 overtemperature condition is exceeded. This bit keeps VDD3/5 regulator disabled as long as this bit is set to 1.
- Cleared to 0 if an overtemperature condition is no longer present

5.5.4.4 SAFETY_STAT_2 Register

Initialization source: NPOR, post LBIST reinitialization

Controller access: Read only (RD_SAFETY_STAT_2)

Figure 5-26. SAFETY_STAT_2 Register

D7	D6	D5	D4	D3	D2	D1	D0
RSV	RSV	CFG_CRC_ER R	EE_CRC_ERR	RSV	WD_FAIL_CNT [2]	WD_FAIL_CNT [1]	WD_FAIL_CNT [0]
0b	0b	0b	0b	0b	1b	0b	1b

D[7:6] RSV

D[5] CFG_CRC_ERR: CRC error status bit for the safety configuration registers

- Safety configuration registers are protected by CRC8.
- This bit is set to 1 when the calculated CRC8 value for the safety configuration registers does not match the expected CRC8 value stored in the SAFETY_CFG register.
- Cleared to 0 when a CRC8 mismatch is no longer present.
- Cleared to 0 when the EEPROM CRC performs without error (regardless of CFG_CRC check result)

D[4] EE_CRC_ERR: EPROM CRC error status bit

- EEPROM content is protected by CRC8.
- This bit is set to 1 when the calculated CRC8 value does not match the expected CRC8 value stored in the EEPROM DFT register. When this bit is set to 1 and device is in the DIAGNOSTIC state, the device transitions to the SAFE state.
- Cleared to 0 when a CRC8 mismatch is no longer present.

D[3] RSV

D[2:0] WD_FAIL_CNT[2:0]: watchdog fail counter

- The default value is 5, and is initialized to this value upon entering the DIAGNOSTIC and ACTIVE state
- Watchdog fail counter increments every time the device watchdog detects a bad or time-out event and decrements each time a good event is received.
- Watchdog fail counter must decrease below 5 to enable the ENDRV pin.
- Watchdog fail is detected on the next bad or time-out event after the watchdog fail counter reached the count of 7 (that is 7+1) while the WD_RST_EN bit is set to 1. The WD_FAIL status bit is set to 1 in the SAFETY_ERR_STAT register (setting the WD_FAIL bit to 1 in the SAFETY_ERR_STAT register).

5.5.4.5 SAFETY_STAT_3 Register

Initialization source: NPOR

Controller access: Read only (RD_SAFETY_STAT_3)

Figure 5-27. SAFETY_STAT_3 Register

D7	D6	D5	D4	D3	D2	D1	D0
RSV	RSV	NRES_ERR	LBIST_ERR	ABIST_ERR	ABIST_ERR	LBIST_RUN	ABIST_RUN
0b	0b	0b	0b	0b	0b	0b	0b

D[7:6] RSV

D[5] NRES_ERR: Reset error input status

- This bit is set to 1 when a mismatch between the NRES pin output HIGH and the NRES pin input readback LOW is detected, regardless of the value of the DIS_RES_MON bit. Depending on the external RC loading of this pin and the timing to read this bit, it may be set to 1 briefly if the external RC delay slows a change in level that is longer than the internal deglitch time (120 μ s typical).
- Cleared to 0 if no failure is present anymore.
- The DIS_NRES_MON bit in the SAFETY_FUNC_CFG register determines if this error causes a state transition from the ACTIVE state to the SAFE state.

D[4] LBIST_ERR: Logic BIST (LBIST) error-status bit

- This bit is set to 1 when the LBIST fails
- Cleared to 0 after a LBIST run is complete without failure
- Only valid when the LBIST_RUN bit is 0

D[3] ABIST_ERR: Analog BIST (ABIST) error-status bit

- This bit is set to 1 when the ABIST fails. If this bit is set to 1 and the device is in the DIAGNOSTIC state, the device transitions to the SAFE state.
- Cleared to 0 after a ABIST run is complete without failure
- Only valid when the ABIST_RUN bit is 0 (ABIST is not running)

D[2] ABIST_ERR: Analog BIST (ABIST) error-status bit (identical to D3)

- This bit is set to 1 when the ABIST fails. If this bit is set to 1 and device is in the DIAGNOSTIC state, the device transitions to the SAFE state.
- Cleared to 0 after a ABIST run is complete without failure
- Only valid when the ABIST_RUN bit is 0 (ABIST is not running)

D[1] LBIST_RUN: Logic BIST (LBIST) run status bit

- This bit is set to 1 when a LBIST is running.
- Cleared to 0 when the LBIST is not running.

D[0] ABIST_RUN: Analog BIST (ABIST) run status bit

- This bit is set to 1 when the ABIST is running.
- Cleared to 0 when the ABIST is not running.

5.5.4.6 SAFETY_STAT_4 Register

Initialization source: NPOR, post LBIST reinitialization

Controller access: Read only (RD_SAFETY_STAT_4)

Figure 5-28. SAFETY_STAT_4 Register

D7	D6	D5	D4	D3	D2	D1	D0
SPI_ERR[1]	SPI_ERR[0]	LOCLK	RSV	MCU_ERR	WD_ERR	ENDRV_ERR	TRIM_ERR_VMON
0b	0b	0b	0b	0b	0b	0b	0b

D[7:6] SPI_ERR[1:0]: SPI error-status bits

00b = No error

01b = SPI SDO error (mismatch on SDO output)

If both a SPI SDO error and another SPI error occur during the same SPI frame, 01b is shown in the SPI_ERR[1:0] bit because the SPI SDO error has priority.

10b = Reserved

11b = SPI errors including truncated SPI frames, SPI transfers with more than 16 bits, SPI transfers with undefined commands or SPI transfers with incorrect command parity

- Cleared to 0 after a SPI read access or any SPI frame with no errors.

Note: If a reset to the MCU is asserted during a SPI frame transfer (causing a truncated SPI frame), these SPI error status bits are not cleared, but maintain the status according to the truncated previous SPI frame until SPI read access

D[5] LOCLK: Loss of clock-detection status bit

- Set when a loss-of-clock failure is detected and also set after the ABIST is complete

- Cleared to 0 after internal NPOR and clear on read (after ABIST)

D[4] RSV

D[3] MCU_ERR: MCU error signal monitor (MCU ESM) status bit

- This bit is set to 1 when the MCU ESM module detects an error on the ERROR/WDI pin while MCU ESM monitoring is enabled.

- This bit mirrors the ERROR_PIN_FAIL bit in the SAFETY_ERR_STAT register

D[2] WD_ERR: Watchdog error-status bit

- This bit is set to 1 on the next bad or time-out event when the WD_FAIL_CNT[2:0] counter reaches a count of 7 (that is 7+1) when the WD_RST_EN bit (bit 3 in the SAFETY_FUNC_CFG) is set to 1. Also set to 1 when the DIAGNOSTIC state time-out occurs.

- This bit mirrors the WD_FAIL bit in the SAFETY_ERR_STAT register

D[1] ENDRV_ERR: Enable driver error

- This bit is set to 1 when a mismatch between the ENDRV pin output and the ENDRV input feedback is detected. Depending on the external RC loading of this pin and the timing to read this bit, it may be set to 1 briefly if the external RC delay slows a change in level that is longer than the internal deglitch time (32 μ s typical).

- Cleared to 0 if the failure is no longer present

D[0] TRIM_ERR_VMON: VMON trimming error-status bit

- This bit is set to 1 when mismatch voltage-monitor trim error is detected.

- Cleared to 0 after an internal NPOR and if failure is not present anymore.

5.5.4.7 SAFETY_STAT_5 Register

Initialization source: POR, post LBIST reinitialization

Controller access: Read only (RD_SAFETY_STAT_5)

Figure 5-29. SAFETY_STAT_5 Register

D7	D6	D5	D4	D3	D2	D1	D0
RSV	RSV	RSV	RSV	RSV	FSM[2]	FSM[1]	FSM[0]
0b	0b	0b	0b	0b	0b	1b	1b

D[2:0] FSM[2:0]: Current device state

– Reflects the current device state (the bits will immediately update to reflect the current device state after an NPOR or post LBIST reinitialization)

- STANDBY state: 00h
- RESET state: 03h
- DIAGNOSTIC state: 07h
- ACTIVE state: 05h
- SAFE state: 04h

5.5.4.8 SAFETY_ERR_CFG Register

Initialization source: NPOR

Controller access: Read (RD_SAFETY_ERR_CFG)

Write (WR_SAFETY_ERR_CFG). Write update can only occur in the DIAGNOSTIC state. Write access locked through SW_LOCK command.

Figure 5-30. Register

D7	D6	D5	D4	D3	D2	D1	D0
SAFE_TO [2]	SAFE_TO [1]	SAFE_TO [0]	SAFE_LOCK_T HR [3]	SAFE_LOCK_T HR [2]	SAFE_LOCK_T HR [1]	SAFE_LOCK_T HR [0]	CFG_LOCK
0b	0b	0b	0b	0b	0b	0b	0b

D[7:5] SAFE_TO[2:0]: SAFE state time-out settings

- Duration of the SAFE state is time-limited to protect against potential MCU *locked* state.
- Time-out duration = $(2 \times \text{SAFE_TO}[2:0] + 1) \times 22 \text{ ms}$
- Minimum duration is 22 ms
- Maximum duration is 330 ms
- 22-ms time reference has 5% accuracy coming from 4-MHz internal oscillator)

D[4:1] SAFE_LOCK_THR[3:0]

- Sets the corresponding device DEV_ERR_CNT[3:0] threshold at which device remains in the SAFE state regardless of SAFE state time-out event
- When the NO_SAFE_TO bit (SAFETY_FUNC_CFG register, bit 7) is set to 1:
 - While $\text{DEV_ERR_CNT}[3:0] < \text{SAFE_LOCK_THR}[3:0] + 1$, SAFE state time-out transition time from the SAFE-to-RESET state is controlled through the SAFE_TO[2:0] bit settings. SAFE state time-out duration is calculated $(\text{SAFE_TO}[2:0] \times 2 + 1) \times 22 \text{ ms}$
 - Device remains *locked* in the SAFE state when the DEV_ERR_CNT[3:0] counter reaches $\text{SAFE_LOCK_THR}[3:0] + 1$ value.
- When the NO_SAFE_TO bit (SAFETY_FUNC_CFG register, bit 7) is cleared to 0:
 - While $\text{DEV_ERR_CNT}[3:0] < \text{SAFE_LOCK_THR}[3:0] + 1$, time-out transition time from the SAFE-to-RESET state is controlled through the SAFE_TO[2:0] bit settings. Time-delay duration is calculated $(\text{SAFE_TO}[2:0] \times 2 + 1) \times 22 \text{ ms}$
 - When the DEV_ERR_CNT[3:0] counter reaches $\text{SAFE_LOCK_THR}[3:0] + 1$ value, the device transitions to the RESET state after 680 ms.
- Intended to support software debug and development and is NOT recommended for normal functional operation.
- The 0000b setting is the default setting, and has same effect as the 1111b setting. Both settings give the minimum threshold.

D[0] CFG_LOCK

- Register lock access control
- When set to 1, the register content cannot be updated by SPI WR access.

5.5.4.9 SAFETY_BIST_CTRL Register

Initialization source: NPOR

Controller access: Read (RD_SAFETY_BIST_CTRL)

Write (WR_SAFETY_BIST_CTRL). Write access locked through SW_LOCK command.

Figure 5-31. SAFETY_BIST_CTRL Register

D7	D6	D5	D4	D3	D2	D1	D0
BIST_DEG_CN T[1]	BIST_DEG_CN T[0]	AUTO_BIST_DI S	EE_CRC_CHK	RSV	LBIST_EN	ABIST_EN	ABIST_EN
0b	0b	0b	0b	0b	0b	0b	0b

D[7:6] BIST_DEG_CNT[1:0]: Deglitch filter duration setting during an active ABIST

- This bit controls the deglitch filter duration for every safety monitored voltage.
- Resolution is 15 μ s (with the minimum setting at 15 μ s and the maximum setting at 60 μ s): $\text{bist_deglitch} = (\text{BIST_DEG_CNT}[1:0] + 1) \times 15 \mu\text{s}$
- 15- μ s time reference has 5% accuracy coming from 4-MHz internal oscillator.
- When the ABIST is run in the ACTIVE state, TI recommends to set this to the maximum deglitch time

D[5] AUTO_BIST_DIS

- This bit controls the automatic BIST run on the transition from the RESET to the DIAGNOSTIC state ONLY when the device enters the RESET state from the DIAGNOSTIC, ACTIVE, or SAFE state.
- When set to 1, automatic BIST run is, except for the automatic BIST run on power up from the STANDBY state

D[4] EE_CRC_CHK: Recalculate EEPROM CRC8

- This bit controls the EEPROM CRC8 check function
- When set to 1, the EEPROM content is reloaded and CRC8 re-calculated and compared against expected value stored in EEPROM DFT register.

Note: With every power-up event, EEPROM content is reloaded and its CRC8 recalculated.

- The self-test status is checked through bit 4 in the SAFETY_STAT_2 register.

D[3] RSV, readable and writable without effect

D[2] LBIST_EN: Enables LBIST run

- This bit controls the LBIST run (which also runs the ABIST)
- The self-test status is monitored through the D1 and D4 bits in the SAFETY_STAT_3 register.
- The LBIST_EN bit clears the DIAG_EXIT_MASK bit to 0. The DIAGNOSTIC state time-out counter only stops during the running of the LBIST. After the LBIST is complete, the time-out counter continues from the last value. To stay in the DIAGNOSTIC state, the DIAG_EXIT_MASK bit must be set to 1 after LBIST completion. For a transition from the DIAGNOSTIC state to the ACTIVE state, the DIAG_EXIT bit must be set to 1.

D[1] ABIST_EN: Enable ABIST run (same as D[0])

- This bit controls the analog UV,OV and LOC BIST run.
- The self-test status is monitored through the D0, D2, and D3 bits in the SAFETY_STAT_3 register, and the D5 bit in the SAFETY_STAT4 register.

D[0] ABIST_EN: Enable analog BIST run (same as D[1])

- The bit controls the analog UV, OV, and LOC BIST run.
- The self-test status is monitored through the D0, D2, and D3 bits in the SAFETY_STAT_3 register, and the D5 bit in the SAFETY_STAT4 register.

5.5.4.10 SAFETY_CHECK_CTRL Register

Initialization source: NPOR, post LBIST reinitialization

Controller access: Read (RD_SAFETY_CHECK_CTRL)

Write (WR_SAFETY_CHECK_CTRL). .

Figure 5-32. SAFETY_CHECK_CTRL Register

D7	D6	D5	D4	D3	D2	D1	D0
CFG_CRC_EN	RSV	ENABLE_DRV	RSV	RSV	NO_ERROR	DIAG_EXIT_M ASK	DIAG_EXIT
0b	0b	0b	1b	0b	1b	0b	0b

D[7] CFG_CRC_EN

- This bit controls the enabling of CRC8 protection for the device configuration registers.
- When set to 1, the CRC8 is calculated for all device configuration registers and compared with the CRC8 value stored in the SAFETY_CFG_CRC register.
- TI recommends to first set the desired device configuration, followed by updating the SAFTY_CFG_CRC register before setting this bit to 1.
- The following registers are protected:
 - SAFETY_FUNC_CFG register
 - DEV_REV (device revision) register
 - SAFETY_PWD_THR_CFG register
 - SAFETY_ERR_CFG register
 - WD_TOKEN_CFG register
 - WD_WIN1_CFG register
 - WD_WIN2_CFG register
 - SAFETY_ERR_PWM_L register
 - DEV_CFG2 register
 - DEV_CFG1 register (only the D6 bit)

D[6] RSV, readable and writeable with no impact to device state or the ENDRV, and NRES output

D[5] ENABLE_DRV

- Controls the enabling of the ENDRV output
- In addition to setting this bit to 1, the watchdog fail counter must be decremented below the default count value of 5 to enable the ENDRV output.

D[4:3] RSV, readable and writeable with no impact to device state or the ENDRV, and NRES output

D[2] NO_ERROR

- This bit enables MCU ESM monitoring of the ERROR/WDI pin. When enabled the MCU ESM transitions the device from the ACTIVE state to the SAFE state when an error is detected.
 - 0b = MCU ESM is enabled and the ERROR/WDI pin is monitored. A detected failure in the ACTIVE state causes a transition to the SAFE state, a detected failure in the DIAGNOSTIC state does not cause a transition to the SAFE state.
 - 1b = MCU ESM is not enabled and the ERROR/WDI pin is not monitored and a failure in the ACTIVE state does not cause a transition to the SAFE state.
- If a failure is detected when NO_ERROR = 0 (MCU ESM is enabled).
 - The ERROR_PIN_FAIL status bit in the SAFETY_ERR_STAT register is set
 - The MCU_ERR status bit in the SAFETY_STAT_4 register is set

D[1] DIAG_EXIT_MASK

- Controls the exit from the DIAGNOSTIC state
- When set to 1, exit from the DIAGNOSTIC state is disabled regardless if a DIAGNOSTIC state time-out event occurs or if the DIAG_EXIT bit is set.
- This feature is only recommended for software debug and development and must not be activated in functional mode.

D[0] DIAG_EXIT

- Controls exit from the DIAGNOSTIC state to the ACTIVE state
- When set to 1 and the DIAG_EXIT_MASK bit is 0, the device transitions from the DIAGNOSTIC to the ACTIVE state.

5.5.4.11 SAFETY_FUNC_CFG Register

Initialization source: NPOR

Controller access: Read (RD_SAFETY_FUNC_CFG)

Write (WR_SAFETY_FUNC_CFG). Write update can only occur in the DIAGNOSTIC state. Write access locked through SW_LOCK command.

Figure 5-33. SAFETY_FUNC_CFG Register

D7	D6	D5	D4	D3	D2	D1	D0
NO_SAFE_TO	ERROR_CFG	WD_CFG	IGN_PWRL	WD_RST_EN	DIS_NRES_MON	RSV	VDD_3_5_SEL
1b	0b	0b	0b	0b	1b	0b	X

D[7] NO_SAFE_TO

- Controls the enabling and disabling of the SAFE state time-out function
 - When set to 1: The SAFE state time-out is disabled. The device remains *locked* in the SAFE state when the DEV_ERR_CNT[3:0] counter reaches the SAFE_LOCK_THR[3:0] + 1 value.
 - When cleared to 0: The SAFE state time-out is enabled. The device transitions to the RESET state after 680 ms when the DEV_ERR_CNT[3:0] counter reaches the SAFE_LOCK_THR[3:0] + 1 value.

D[6] ERROR_CFG: MCU ESM configuration bit

- When cleared to 0: PWM Mode is selected (can be used as an external clock monitor). The expected ERROR/WDI pin LOW and HIGH durations are controlled by the SAFETY_ERR_PWM_H and SAFETY_ERR_PWM_L registers (see [Section 5.5.4.14](#), respectively).
- When set to 1: The TMS570 mode is selected. The ERROR pin low-duration threshold is set by the SAFETY_ERR_PWM_L register.
- Use the NO_ERROR bit in the SAFETY_CHECK_CTRL register to enable the MCU ESM function

D[5] WD_CFG: Watchdog function configuration bit

- When cleared to 0: Trigger mode (default) – watchdog trigger input through the ERROR/WDI pin
- When set to 1: Q&A mode – watchdog answers input through SPI

D[4] IGN_PWRL: Ignition-power latch control bit

- Controls the enabling of the ignition-power latch
 - Note:** This bit can only be changed when the device is in the DIAGNOSTIC state
- When cleared to 0: With the IGN pin LOW, the device enters the STANDBY state. Cleared by a CANWU event
- When set to 1: The IGN pin can be pulled LOW, but the device remains powered up.

D[3] WD_RST_EN

- 1b = Enables a transition to the RESET state when a Watchdog failure is detected (the WD_FAIL_CNT[2:0] counter reaches the count of 7+1).
- 0b (default) = Disables a transition to the RESET state when watchdog failure events are detected (the WD_FAIL_CNT[2:0] counter reaches the count of 7 + 1).

D[2] DIS_NRES_MON

- When cleared to 0: In the ACTIVE state, a difference between the read-back level on the NRES pin and the NRES pin output driver state causes a transition to the SAFE state and the NRES_ERR bit is set.
- When set to 1 (default state): State transition because of a difference between the read-back NRES pin level and the NRES driver state is disabled. (default state) **Note:** The NRES_ERR bit is still set if a difference between the read-back NRES pin level and the NRES driver state is detected.

D[1] RSV, readable and writeable in the DIAGNOSTIC state with no impact to the device state or the ENDRV and NRES output

D[0] VDD_3_5_SEL: Status bit of VDD3/VDD5 selection at power up

- The SEL_VDD3/5 input pin is sampled and latched at power up
 - 0b = 5-V setting (pin SEL_VDD3/5 connected to ground)
 - 1b = 3.3-V setting (the SEL_VDD3/5 pin is not connected)
 - Value in the RESET state depends on the state of the SEL_VDD3/5 pin at first power up
- This bit is read only
 - Note:** This bit is the same as the DEV_CFG1 bit, D7

5.5.4.12 SAFETY_ERR_STAT Register

Initialization source: NPOR

Controller access: Read (RD_SAFETY_ERR_STAT)

Write (WR_SAFETY_ERR_STAT). Write update can only occur in the DIAGNOSTIC state. Write access locked through SW_LOCK command.

Figure 5-34. SAFETY_ERR_STAT Register

D7	D6	D5	D4	D3	D2	D1	D0
RSV	RSV	ERROR_PIN_F AIL	WD_FAIL	DEV_ERR_CN T[3]	DEV_ERR_CN T[2]	DEV_ERR_CN T[1]	DEV_ERR_CN T[0]
0b	0b	0b	0b	0b	0b	0b	0b

D[7:6] RSV

D[5] ERROR_PIN_FAIL

- Set to 1 when the MCU ESM Module detects a failure on the ERROR/WDI pin, only if NO_ERROR = 0 (bit D2 in SAFETY_CHECK_CTRL register). The device enters the SAFE state when this ERROR_PIN_FAIL bit is set to 1 while the device is in the ACTIVE state and NO_ERROR = 0. Also set to 1 when a DIAGNOSTIC state time-out occurs.
- Cleared by using SPI to write a 0 to the bit or cleared to 0 during reset event. **Note:** in the DIAGNOSTIC state it is also possible to write this bit to 1, leaving it set at 1 will have the same device level impact as a detected failure on the ERROR/WDI pin.

D[4] WD_FAIL

- This bit is set to 1 on the next bad event when the watchdog fail counter reaches a count of 7 (that is 7 + 1) (the WD_FAIL_CNT[2:0] bits in the SAFETY_STAT_2 register) when the WD_RST_EN bit (bit 3 in SAFETY_FUNC_CFG) is set to 1. Also set to 1 when the DIAGNOSTIC state time-out occurs.
- Cleared by using the SPI to write a 0 to the bit when the watchdog fail counter is less than 7 or cleared to 0 during a reset event. **Note:** in the DIAGNOSTIC state, writing this bit to 1 is also possible, leaving it set at 1 when exiting the DIAGNOSTIC state causes a transition to the SAFE state.

D[3:0] DEV_ERR_CNT[3:0]

- Tracks the current device error count.
- Overwritten by SPI WR access, but ONLY in the DIAGNOSTIC mode.

5.5.4.13 SAFETY_ERR_PWM_H Register

Initialization source: NPOR

Controller access: Read (RD_SAFETY_ERR_PWM_H)

Write (WR_SAFETY_ERR_PWM_H). Write update can only occur in the DIAGNOSTIC state. Write access locked through SW_LOCK command.

Figure 5-35. SAFETY_ERR_PWM_H Register

D7	D6	D5	D4	D3	D2	D1	D0
PWMH[7]	PWMH[6]	PWMH[5]	PWMH[4]	PWMH[3]	PWMH[2]	PWMH[1]	PWMH[0]
1b	0b	1b	0b	1b	0b	0b	0b

D[7:0] PWMH[7:0]: The ERROR/WDI pin high-phase duration in PWM mode (15- μ s resolution)

- Controls the expected high-phase duration with 15- μ s resolution
Use [Equation 17](#) and [Equation 18](#) to calculate the minimum and maximum values for the HIGH pulse duration, t_{PWM_HIGH} . (15- μ s time reference has 5% accuracy coming from 4-MHz internal oscillator)

5.5.4.14 SAFETY_ERR_PWM_L Register

Initialization source: NPOR

Controller access: Read (RD_SAFETY_ERR_PWM_L)

Write (WR_SAFETY_ERR_PWM_L). Write update can only occur in the DIAGNOSTIC state. Write access locked through SW_LOCK command.

Figure 5-36. SAFETY_ERR_PWM_L Register

D7	D6	D5	D4	D3	D2	D1	D0
PWML[7]	PWML[6]	PWML[5]	PWML[4]	PWML[3]	PWML[2]	PWML[1]	PWML[0]
0b	0b	1b	1b	1b	1b	0b	1b

D[7:0] PWML[7:0]: The ERROR/WDI pin low-phase duration

- Controls expected low-phase duration
 - When the ERR_CFG bit is 0 (in PWM mode): PWM low-phase duration with 15- μ s resolution
Use Equation 19 and Equation 20 to calculate the minimum and maximum values for the LOW pulse duration, t_{PWM_LOW} . (15- μ s time reference has 5% accuracy coming from 4-MHz internal oscillator)
 - When ERR_CFG bit is 1 (TMS570 mode): error low duration with 5- μ s resolution
Use Equation 15 and Equation 16 to calculate the minimum and maximum values for the LOW duration, t_{TMS570_LOW} . (5- μ s time reference has 5% accuracy coming from 4-MHz internal oscillator)

5.5.4.15 SAFETY_PWD_THR_CFG Register

Initialization source: NPOR

Controller access: Read (RD_SAFETY_PWD_THR_CFG)

Write (WR_SAFETY_PWD_THR_CFG). Write update can only occur in the DIAGNOSTIC state. Write access locked through SW_LOCK command.

Figure 5-37. SAFETY_PWD_THR_CFG Register

D7	D6	D5	D4	D3	D2	D1	D0
RSV	RSV	RSV	RSV	PWD_THR[3]	PWD_THR[2]	PWD_THR[1]	PWD_THR[0]
0b	0b	0b	0b	1b	1b	1b	1b

D[7:4] RSV

D[3:0] PWD_THR[3:0]: Device error-count threshold to power down the device

- When the DEV_ERR_CNT[3:0] counter reaches the programmed threshold, the device powers down.
- The device recovers with a new wake-up or ignition event.

5.5.4.16 SAFETY_CFG_CRC Register

Initialization source: NPOR

Controller access: Read (RD_SAFETY_CFG_CRC)

Write (WR_SAFETY_CFG_CRC). Write update can only occur in the DIAGNOSTIC state. Write access locked through SW_LOCK command.

Figure 5-38. SAFETY_CFG_CRC Register

D7	D6	D5	D4	D3	D2	D1	D0
CFG_CRC[7]	CFG_CRC[6]	CFG_CRC[5]	CFG_CRC[4]	CFG_CRC[3]	CFG_CRC[2]	CFG_CRC[1]	CFG_CRC[0]
0b	0b	0b	1b	0b	0b	0b	0b

D[7:0] CFG_CRC[7:0]: The CRC8 value for the safety configuration registers

5.5.4.17 Diagnostics

5.5.4.17.1 DIAG_CFG_CTRL Register

Initialization source: NPOR, post LBIST reinitialization

Controller access: Read (RD_DIAG_CFG_CTRL)

Write (WR_DIAG_CFG_CTRL)

Figure 5-39. DIAG_CFG_CTRL Register

D7	D6	D5	D4	D3	D2	D1	D0
MUX_EN	SPI_SDO	MUX_OUT	INT_CON[2]	INT_CON[1]	INT_CON[0]	MUX_CFG[1]	MUX_CFG[0]
0b	0b	0b	0b	0b	0b	0b	0b

D[7] MUX_EN: Enable diagnostic MUX output

0b = Disabled (tri-stated)

1b = Enabled

D[6] SPI_SDO: To control the SPI_SDO output-buffer state during an interconnect test

To check the SDO diagnostics use the following sequence:

- MUX_CFG[1:0] configuration must be 01b (Digital MUX Mode)
- SPI NCS must be kept HIGH
- The state of the SDO pin is controlled by the SPI_SDO bit

D[5] MUX_OUT: Diagnostic MUX output-state control bit

Note: When the MUX_CFG bits are set to 00b and the MUX_EN bit is set to 1

D[4:2] INT_CON[2:0]: Device interconnect-test configuration bits

000b = No active interconnect test

001b = ERR input state observed on the diagnostic MUX output

010b = SPI_NCS input state observed on the diagnostic MUX output

011b = SPI_SDI input state observed on the diagnostic MUX output

100b = SPI_SCLK input observed on the diagnostic MUX output

101b = Not applicable

110b = Not applicable

111b = Not applicable

D[1:0] MUX_CFG[1:0]: Diagnostic MUX configuration

00b = The MUX output is controlled by MUX_OUT bit (bit 5 in DIAG_CFG_CTRL register)

01b = Digital MUX mode

10b = Analog MUX mode

11b = Device interconnect mode (input-pins interconnect test)

5.5.4.17.2 DIAG_MUX_SEL Register

Initialization source: NPOR, post LBIST reinitialization

Controller access: Read (RD_DIAG_MUX_SEL)

Write (WR_DIAG_MUX_SEL)

Figure 5-40. DIAG_MUX_SEL Register

D7	D6	D5	D4	D3	D2	D1	D0
MUX_SEL[7]	MUX_SEL[6]	MUX_SEL[5]	MUX_SEL[4]	MUX_SEL[3]	MUX_SEL[2]	MUX_SEL[1]	MUX_SEL[0]
0b	0b	0b	0b	0b	0b	0b	0b

D[7:0] MUX_SEL[7:0]: Diagnostic MUX channel select

Note: The MUX channel table is dependent on the MUX_CFG[1:0] bit settings in the DIAG_CFG_CTRL register (see [Section 5.5.4.17.1](#))

5.5.5 Watchdog Timer

5.5.5.1 WD_TOKEN_FDBK Register

Initialization source: NPOR

Controller access: Read (RD_WD_TOKEN_FDBK)

Write (WR_WD_TOKEN_FDBK). Write update can only occur in the DIAGNOSTIC state. Write access locked through SW_LOCK command.

Figure 5-41. WD_TOKEN_FDBK Register

D7	D6	D5	D4	D3	D2	D1	D0
FDBK[3]	FDBK[2]	FDBK[1]	FDBK[0]	TOKEN_SEED[3]	TOKEN_SEED[2]	TOKEN_SEED[1]	TOKEN_SEED[0]
0b	0b	0b	0b	0b	0b	0b	0b

D[7:4] FDBK[3:0]: Watchdog question (token) FSM feedback configuration bits

- FDBK [3:0] bits control the sequence of generated questions and Markov chain polynomial
- The device has a set of 16 generated questions, repetition or sequence ordering can be adjusted by the FDBK[3:0] bits
- FDBK[3:2] controls the question (TOKEN) generation for the watchdog in Q&A mode
- FDBK[2:1] controls the LFSR configuration for the watchdog question (TOKEN) generation
- FDBK[0] RSV

D[3:0] TOKEN_SEED[3:0]: Watchdog token seed value, used to generate a set of new questions (tokens)

- The token seed value can be updated by the MCU only after watchdog is reinitialization in the DIAGNOSTIC state after RESET. The new TOKEN_SEED[3:0] value takes effect after another transition through the RESET state with AUTO_BIST_DIS = 1:
- Only for Q&A Mode

5.5.5.2 WD_WIN1_CFG Register

Initialization source: NPOR

Controller access: Read (RD_WD_WIN1_CFG)

Write (WR_WD_WIN1_CFG). Write update can only occur in the DIAGNOSTIC state. Write access locked through SW_LOCK command.

Figure 5-42. WD_WIN1_CFG Register

D7	D6	D5	D4	D3	D2	D1	D0
RSV	RT[6]	RT[5]	RT[4]	RT[3]	RT[2]	RT[1]	RT[0]
0b	1b	1b	1b	1b	1b	1b	1b

D[7] RSV

D[6:0] RT[6:0]: Watchdog Window 1 duration setting

- See [Equation 1](#) and [Equation 2](#) to calculate the minimum and maximum values for the t_{WIN1} time period.

5.5.5.3 WD_WIN2_CFG Register

Initialization source: NPOR

Controller access: Read (RD_WD_WIN2_CFG)

Write (WR_WD_WIN2_CFG). Write update can only occur in the DIAGNOSTIC state. Write access locked through SW_LOCK command.

Figure 5-43. WD_WIN2_CFG Register

D7	D6	D5	D4	D3	D2	D1	D0
RSV	RSV	RSV	RW[4]	RW[3]	RW[2]	RW[1]	RW[0]
0b	0b	0b	1b	1b	0b	0b	0b

D[7:5] RSV

D[4:0] RW[4:0]: Watchdog Window 2 duration setting

- See [Equation 3](#) and [Equation 4](#) to calculate the minimum and maximum values for the t_{WIN2} time period.

5.5.5.4 WD_TOKEN_VALUE Register

Initialization source: NPOR, post LBIST reinitialization

Controller access: Read only (RD_WD_TOKEN_VALUE)

Figure 5-44. WD_TOKEN_VALUE Register

D7	D6	D5	D4	D3	D2	D1	D0
WD_FAIL_TH	RSV	RSV	RSV	TOKEN[3]	TOKEN[2]	TOKEN[1]	TOKEN[0]
1b	0b	0b	0b	0b	0b	0b	0b

D[7] WD_FAIL_TH

- Set to 1 when the watchdog fail counter reaches a count of 5 or higher (WD_FAIL_CNT[2:0] bits in the SAFETY_STAT_2 register)
- Cleared to 0 when the watchdog fail counter reaches a count of less than 5 (WD_FAIL_CNT[2:0] bits in the SAFETY_STAT_2 register)

D[6:4] RSV

D[3:0] TOKEN[3:0]: watchdog question (token)

- The MCU must read (or calculate) the current question (token) to generate a correct answer bytes.
- Only for Q&A mode

5.5.5.5 WD_STATUS Register

Initialization source: NPOR, post LBIST reinitialization

Controller access: Read only (RD_WD_STATUS)

Figure 5-45. WD_STATUS Register

D7	D6	D5	D4	D3	D2	D1	D0
WD_ANSW_CNT [1]	WD_ANSW_CNT [0]	ANSWER_ERR	WD_WRONG_CFG	WD_CFG_CHG	SEQ_ERR	TIME_OUT	ANSWER_EARLY
1b	1b	0b	0b	0b	0b	0b	0b

D[7:6] WD_ANSW_CNT[1:0]: Current watchdog answer count

- Only for Q&A mode

D[5] ANSWER_ERR: Watchdog error-status bit to show the incorrect Answer-x byte (formerly TOKEN_ERR)

- This bit is set to 1 as soon as an Answer-x byte (WD_TOKEN_RESPx) is not correct. This flag is cleared if the following answer is correct again or at the beginning of a new watchdog sequence. This bit is not cleared on SPI read-out.
- Only for Q&A mode

D[4] WD_WRONG_CFG

- Set to 1 when either the WD_WIN1_CFG or WD_WIN2_CFG bits are set to 00h.

D[3] WD_CFG_CHG: Watchdog configuration-change status bit

- This bit is set to 1 when WD_WIN1_CFG or WD_WIN2_CFG setting is changed. This bit is cleared at the beginning of a new watchdog sequence.

D[2] SEQ_ERR: Any of the answer bytes are wrong

- Incorrect timing or wrong answer
- Only for Q&A mode

D[1] TIME_OUT: No watchdog event (trigger or four answer-x bytes) received within the watchdog sequence (time-out event)

- In trigger mode (default): set to 1 when no trigger has been received on the ERROR/WDI pin during the watchdog sequence
 - In Q&A mode: set to 1 when less than four Answer-x bytes have been received during the watchdog sequence
 - This flag can be used to resynchronize the MCU timing to the device watchdog.
 - Cleared to 0 by SPI read access, cleared to 0 after a watchdog *good event* or *bad event*, or cleared to 0 during reset event.
- Note:** In the DIAGNOSTIC state, writing this bit to 1 is possible, leaving it set at 1 has the same device level impact as a detected failure on the ERROR/WDI pin.

D[0] ANSWER_EARLY: Answer-x bytes completed too early or trigger too early (formerly TOKEN_EARLY)

- Set to 1 if the four answer bytes are returned during Window 1 or the trigger occurs in Window 1

5.5.5.6 WD_ANSWER Register

Initialization source: NPOR

Controller access: Write only (WR_WD_ANSWER)

Figure 5-46. WD_ANSWER Register

D7	D6	D5	D4	D3	D2	D1	D0
WD_ANSW[7]	WD_ANSW[6]	WD_ANSW[5]	WD_ANSW[4]	WD_ANSW[3]	WD_ANSW[2]	WD_ANSW[1]	WD_ANSW[0]
0b	0b	0b	0b	0b	0b	0b	0b

D[7:0] **WD_ANSW[7:0]:** answer bytes

- See [Section 5.4.15.4](#) for details on answer bytes
- Only for Q&A mode

5.5.6 Sensor Supply

5.5.6.1 SENS_CTRL Register

Initialization source: NPOR

Controller access: Read (RD_SENS_CTRL)

Write (WR_SENS_CTRL)

Figure 5-47. SENS_CTRL Register

D7	D6	D5	D4	D3	D2	D1	D0
RSV	RSV	RSV	VDD5_EN	RSV	RSV	RSV	VSOUT1_EN
0b	0b	0b	1b	0b	0b	0b	0b

D[7:5] RSV

D[4] **VDD5_EN:** If cleared to 0, the VDD5 regulator turns off.

- This bit is set to 1 by default, and is cleared in case of the VDD5 over temperature condition (indicated by the VDD5_OT bit D1 in the SAFETY_STAT1 register).

Note: When the VDD5 regulator is disabled, the VDD5_ILIM bit (bit D7 in the SAFETY_STAT_1 register) is set to 1 and remains set to 1 as long as the VDD5 regulator is disabled (or the VDD5_EN bit is 0). However, the VDD5_OV and VDD5_UV bits reflect an overvoltage or undervoltage condition on the VDD5 regulator.

D[3:1] RSV

D[0] **VSOUT1_EN:** Sensor-supply enable bit (set this bit to 1 to enable the VSOUT1 sensor supply)

- This bit is cleared to 0 by default, and must be set to 1 by the MCU to enable the VSOUT1 sensor supply. In case of a VSOUT1 overtemperature condition (indicated by the VSOUT1_OT bit D2 in the SAFETY_STAT1 regulator), the VSOUT1 regulator is disabled and this bit, VSOUT1_EN, is cleared to 0. When the overtemperature condition in the VSOUT1 sensor supply is no longer present, the VSOUT1 sensor supply must be reenabled.

6 Application and Implementation

NOTE

Information in the following applications sections is not part of the TI component specification, and TI does not warrant its accuracy or completeness. TI's customers are responsible for determining suitability of components for their purposes. Customers should validate and test their design implementation to confirm system functionality.

6.1 Application Information

The TPS65381A-Q1 device is a multirail power supply including one buck preregulator, one linear controller, one 5-V linear regulator, one programmable 3.3-V or 5-V linear regulator, and one linear tracking regulator with protection against short to battery and ground. The device has many diagnostic and monitoring functions. This device provides a power-management basis for many different applications.

6.2 Typical Application

The following design requirements and design procedure are an example of how to select component values for the TPS65381A-Q1 device for a typical application. Because many of the regulators are adjustable, the equations should be used to calculate the component values for the specific application. For additional reference, also refer to the design checklist and application notes listed in [9.1.1](#).

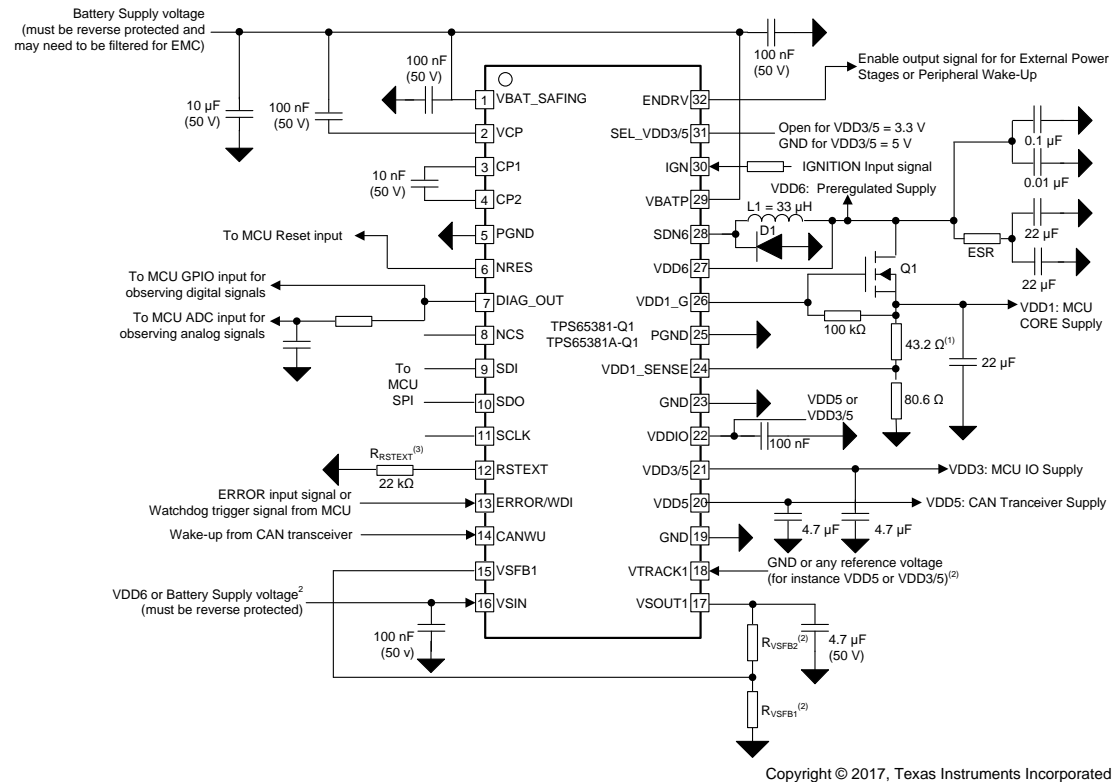

Example components:

- Q1: BUK9213-30A
- D1: Vishay SS3H09/10, OnSemi MBRS340T3
- D2: ROHM UDZSTE-176.2B
- L1: TDK CLF10060NIT-330M-D or COILCRAFT MSS1246T-333ML

NOTE:

1. 43.2 Ω for 1.23-V output voltage (Recommended for TI TMS570 MCU). Change this resistor to obtain different VDD1 output voltage, $VDD1_SENSE = 800\text{ mV}$. The tolerance of the resistors in this resistor divider will impact VDD1 regulation and voltage monitoring tolerance. Resistors with 0.1% tolerance are recommended.
2. R_{VSFB1} and R_{VSFB2} configure the VSOUT1 voltage
 - Pin 16 (VSIN) to be connected either to pin 27 (VDD6) for $VSOUT1 \leq 5\text{ V}$ or to pin 29 (VBATP) for $5\text{ V} < VSOUT1 < 9.5\text{ V}$
 - Pin 18 (VTRACK1) to be connected to GND for non-tracking mode, or a reference voltage (for example VDD5 or VDD3/5) for tracking mode.
 - The tolerance of the resistors in this resistor divider will impact VSOUT1 regulation and voltage monitoring tolerance. Resistors with 0.1% tolerance are recommended.
 - See [Section 5.3.5](#) for details.
3. R_{RSEXT} configures the Reset Extension time. See the *Reset and Enable outputs* section of [Section 4.5](#)

Figure 6-1. Typical Application Diagram

6.2.1 Design Requirements

While selecting capacitors for the application consider the following characteristics:

- The effective capacitance at the operating voltage must be used when selecting the proper capacitor. Capacitors derate with operating voltage, sometimes as much as 70%. Therefore the capacitance of the circuit could be outside of the specified value for the capacitor as listed in [Section 4](#).
- The temperature and lifetime of the capacitor can also impact the effective capacitance and should be considered.
- The voltage ratings of the capacitor should be considered, especially on the high-voltage input circuits that can also experience transient voltages.

These impacts must all be considered when selecting a capacitor so that the circuit has the specified capacitance required for this device at the application operating conditions of the capacitor such as temperature, voltage, and lifetime.

The VBATP and VBAT_SAFING pins are the supply inputs to the device. These supplies must be reverse-battery protected. The supplies should also be adequately protected against transients and have sufficient noise filtering for the intended application. If the application has noisy and high-current output drives that are connected to either the VBATP pin, VBAT_SAFING pin, or both, additional filtering may be necessary between the output drive and the device.

The IGN pin is a wake-up input to the device. This input provides up to –7 V of protection. Beyond this voltage, the IGN pin must be reverse protected. If the noise can occur longer than the specified deglitch time, the IGN pin should also be adequately protected against transients and have sufficient noise filtering for the intended application.

6.2.2 Detailed Design Procedure

6.2.2.1 VDD6 Preregulator

The inductor, output capacitor, and total effective series resistance (ESR) of the output capacitance must be considered to achieve balanced operation of the VDD6 preregulator.

The output inductor must be greater than or equal to the minimum 22- μ H inductance. The typical specified inductance is 33 μ H, which was selected for this design.

The effective output capacitance for the VDD6 preregulator is specified from 22 μ F to 47 μ F. An effective capacitance of 22 μ F at the 6-V DC operating point was selected for this design. This value allows for additional downstream input capacitance on voltage regulator inputs. To filter high frequencies, use 10-nF and 0.1- μ F capacitors in parallel. If higher effective capacitance is used, the voltage ripple is reduced and lowers the required ESR. The effective capacitance of a capacitor should be provided by the capacitor supplier and must be derated for tolerance, lifetime, temperature, and operating voltage.

Because the VDD6 preregulator is a hysteretic architecture, controlled ESR is required with the output capacitance. The specified ESR range is from 100 m Ω to 300 m Ω . Use [Equation 21](#) to calculate the minimum total ESR to achieve balanced operation.

$$R_{ESR} = L / (15 \times C_{Effective}) = 33 / (15 \times 22) = 100 \text{ m}\Omega \quad (21)$$

As an example, the data sheet for the capacitor states that the ESR of the capacitor is 4 m Ω and the parasitic extraction of the PCB design is 6 m Ω . An ESR resistor of 100 m Ω can still be used, or the discrete ESR resistor can be sized to 90 m Ω resulting in a total effective ESR of at least 100 m Ω . If a larger effective capacitance is used, the equation may result in an ESR value below 100 m Ω . In this case, the total ESR should still be brought up to 100-m Ω total ESR minimum to meet the specification.

A high-voltage surface-mount Schottky-rectifier diode, such as SS3H9/10 or MBR340T3, should be used.

[Figure 6-2](#) shows this configuration.

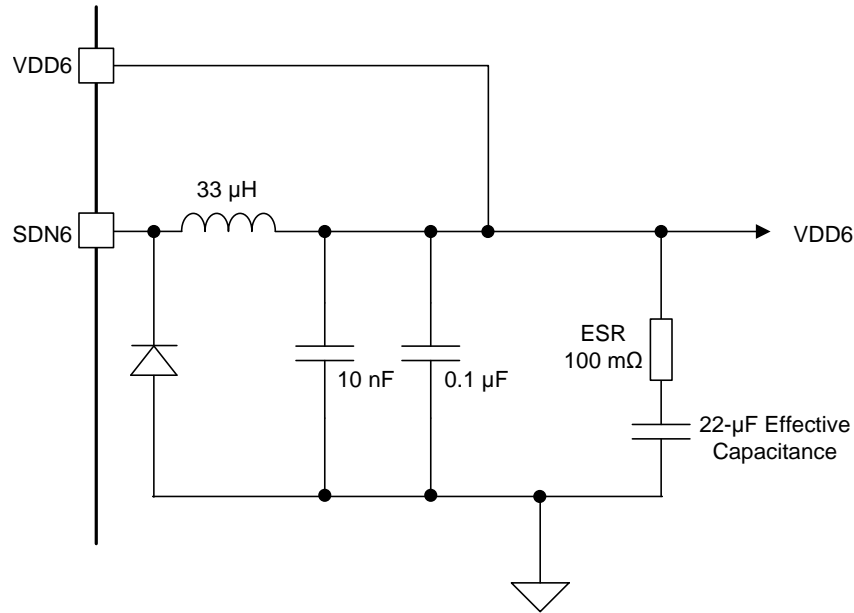

Figure 6-2. VDD6 Design

6.2.2.2 VDD1 Linear Controller

The microprocessor used with the TPS65381A-Q1 device requires a core voltage of 1.23 V.

The output voltage of the VDD1 linear controller is set by a resistor divider from the VDD1 output to ground with the divided voltage connected to the VDD1_SENSE pin, which must be set to 800 mV. To ensure sufficient bias current through the resistor divider, select a value of R1 as 80.6 Ω. Use Equation 22 to calculate the resistance of R2.

$$R2 = ([VDD1 \times R1] / V_{VDD1_SENSE}) - R1 = ([1.23 \text{ V} \times 80.6 \Omega] / 0.8 \text{ V}) - 80.6 \Omega = 43.3 \Omega \quad (22)$$

Select the standard value of 43.2 Ω.

NOTE

The tolerance of the R1 and R2 resistors in this resistor divider will impact the VDD1 regulation and voltage monitoring tolerance. Resistors with 0.1% tolerance are recommended.

Select an output FET for the VDD1 linear controller that meets the requirements in the *VDD1 – LDO With External FET* specifications in Section 4.5. An example output FET is BUK9213-30A. The gate of the output FET is connected to the VDD1_G pin. A 100-kΩ resistor is connected between the gate and source of the FET. The drain of the FET is connected to the VDD6 preregulator output, which is used as the supply input for the VDD1 linear controller.

A low-ESR ceramic output capacitor with 22-µF effective capacitance at 1.23 V is used to meet the requirements for the output capacitor that is listed in this data sheet. Depending on the application, this output may require a larger output capacitor to ensure the output does not drop below the required regulation specification during load transients. The VDD1 output capacitance is specified up to 40 µF.

Figure 6-3 shows this configuration.

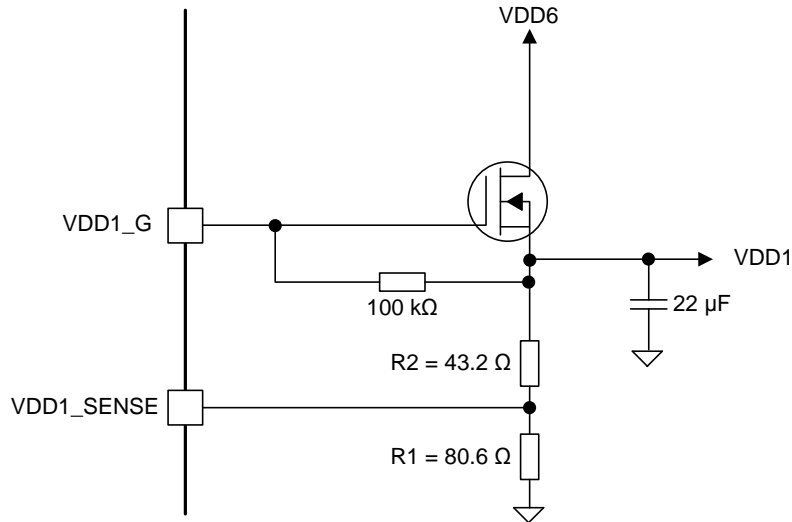

Figure 6-3. VDD1 Design

6.2.2.3 VSOUT1 Tracking Linear Regulator, Configured to Track VDD5

The system has a sensor that requires a 5-V supply that must track the VDD5 supply. The configuration should be set up for higher efficiency.

The VDD5 output is connected to the VTRACK1 pin, which configures the regulator for tracking mode. Because the output must track the input, unity gain feedback is used on the VSFB1 pin by connecting it to the VSOUT1 pin.

For efficiency, use the VDD6 preregulator as the supply. Therefore, the VDD6 output is connected to VSIN. A local, low-ESR 100-nF ceramic capacitor is used on the VSIN pin to stabilize the input.

A local, low-ESR 4.7-μF ceramic capacitor is used on the VSOUT1 output for loop stabilization. Depending on the application, this output may require a larger output capacitor to ensure that the output does not drop below the required regulation specification during load transients. The VSOUT1 output capacitance is specified up to 10 μF.

Figure 6-4 shows this configuration.

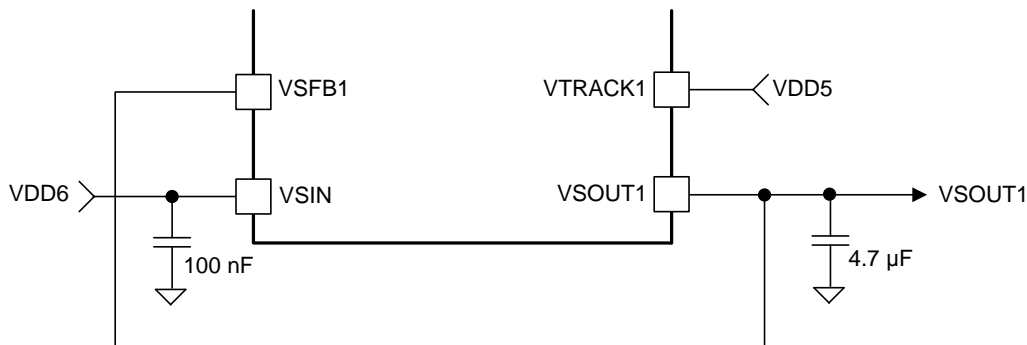

Figure 6-4. VSOUT1 Design—Tracking, No Gain

6.2.2.4 Alternative Use for VSOUT1 Tracking Linear Regulator, Configured for 6-V Output Tracking VDD3/5 In 3.3-V Mode

The system has a sensor that requires a 6-V supply that must track the VDD3/5 supply operating at 3.3 V.

The VDD3/5 supply, operating in 3.3-V mode, is connected to the VTRACK1 pin, which configures the regulator for tracking mode. Because the output must have gain to make the 6-V output track a 3.3-V supply, gain feedback is used on the VSFB1 pin. To achieve the required gain, connect a resistor divider the VSOUT1 and VSFB1 pins. Select a value of 3.3 kΩ for the R_{VSFB1} resistor to balance the current through the resistor divider for reasonable bias current and reasonable losses. Use Equation 23 to calculate the resistance of R_{VSFB2}.

$$R_{VSFB2} = ([VSOUT1 \times R_{VSFB1}] / VTRACK) - R_{VSFB1} = ([6 \text{ V} \times 3.3 \text{ k}\Omega] / 3.3 \text{ V}) - 3.3 \text{ k}\Omega = 2.7 \text{ k}\Omega \quad (23)$$

Select the standard value of 2.7 kΩ.

NOTE

The tolerance of the R_{VSFB1} and R_{VSFB2} resistors in this resistor divider will impact the VSOUT1 regulation and voltage monitoring tolerance. Resistors with 0.1% tolerance are recommended.

Because the desired VSOUT1 output is greater than 5 V, the VBATP supply must be used for the tracking supply. Therefore, connect the VBATP supply to the VSIN pin. A local, low-ESR 100-nF ceramic capacitor is used on the VSIN pin to stabilize the input.

A local, low-ESR 4.7-μF ceramic capacitor is used on the VSOUT1 pin for loop stabilization. Depending on the application, this output may require a larger output capacitor to ensure that the output does not drop below the required regulation specification during load transients. The VSOUT1 output capacitance is specified up to 10 μF.

Figure 6-5 shows this configuration.

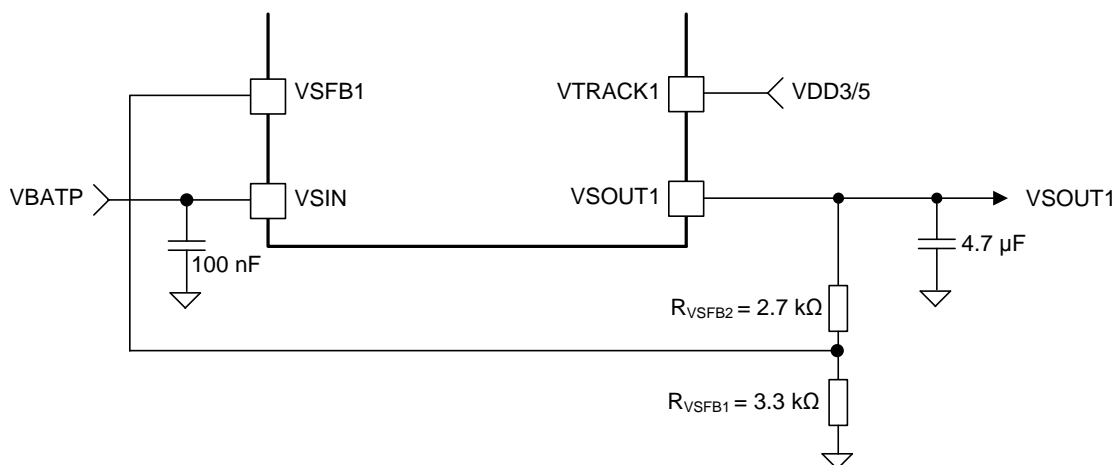

Figure 6-5. VSOUT1 Design—Tracking, With Gain (VDD3/5)

6.2.2.5 Alternative Use for VSOUT1 Tracking Linear Regulator, Configured for 9-V Output Tracking to 5-V Input from VDD5

The system has a sensor that requires a 9-V supply that must track the VDD5 supply operating at 5 V.

The VDD5 supply is connected to VTRACK1, which configures the regulator for tracking mode. Because the output must have gain to make the 9-V output track a 5-V supply, gain feedback is used on the VSFB1 pin. To achieve the required gain, connect a resistor divider between the VSOUT1 and VSFB1 pins. Select a value of 3.3 kΩ for the R_{VSFB1} resistor to balance the current through the resistor divider for reasonable bias current and reasonable losses. Use Equation 24 to calculate the resistance of R_{VSFB2}.

$$R_{VSFB2} = ([VSOUT1 \times R_{VSFB1}] / VTRACK) - R_{VSFB1} = ([9 \text{ V} \times 3.3 \text{ k}\Omega] / 5 \text{ V}) - 3.3 \text{ k}\Omega = 2.64 \text{ k}\Omega \quad (24)$$

Select the standard value of 2.7 kΩ.

NOTE

The tolerance of the R_{VSFB1} and R_{VSFB2} resistors in this resistor divider will impact the VSOUT1 regulation and voltage monitoring tolerance. Resistors with 0.1% tolerance are recommended.

Because the desired VSOUT1 output is greater than 5-V, the VBATP supply must be used as the tracking supply. Therefore, connect the VBATP supply to the VSIN pin. A local, low-ESR 100-nF ceramic capacitor is used on the VSIN pin to stabilize the input.

A local, low-ESR 4.7-μF ceramic capacitor is used on the VSOUT1 pin for loop stabilization. Depending on the application, this output may require a larger output capacitor to ensure that the output does not drop below the required regulation specification during load transients. The VSOUT1 output capacitance is specified up to 10 μF.

Figure 6-6 shows this configuration.

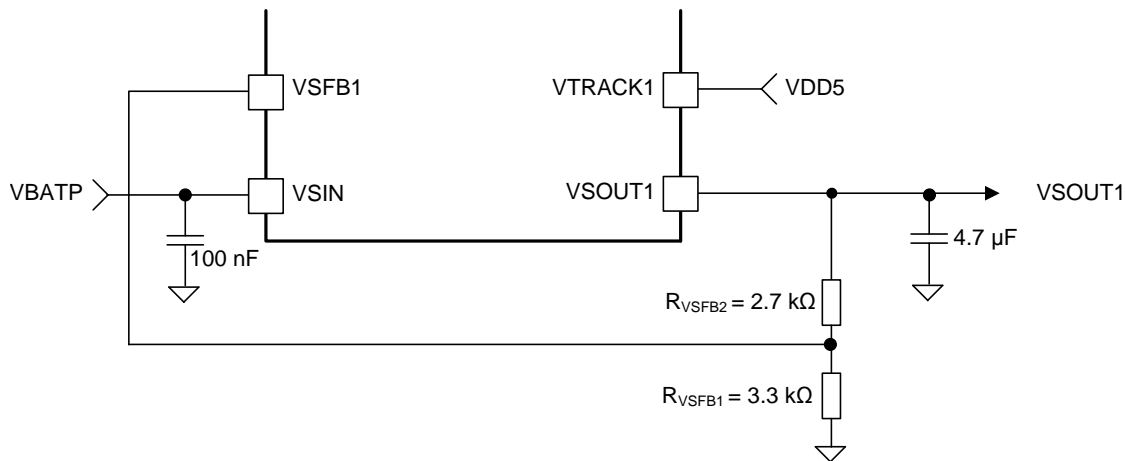

Figure 6-6. VSOUT1 Design—Tracking, With Gain (VDD5)

6.2.2.6 Alternative Use for VSOUT1 Tracking Linear Regulator, Configured in Non-tracking Mode Providing a 4.5-V Output

If the system requires a 4.5-V supply that does not track any other supply, the VTRACK1 pin is connected to ground (GND), which configures the regulator for non-tracking mode. The output is now proportional to a fixed reference voltage (V_{ref}) of 2.5 V on the VSFB1 pin. Because the output must have gain to result in a 4.5-V output, gain feedback will be used on the VSFB1 pin. To achieve the required gain, connect a resistor divider between the VSOUT1 and VSFB1 pins. Select a value of 3.3 k Ω for the R_{VSFB1} resistor to balance the current through the resistor divider for reasonable bias current and reasonable losses. Use Equation 25 to calculate the resistance of R_{VSFB2}.

$$R_{VSFB2} = ((VSOUT1 \times R_{VSFB1}) / V_{ref}) - R_{VSFB1} = ((4.5 \text{ V} \times 3.3 \text{ k}\Omega) / 2.5 \text{ V}) - 3.3 \text{ k}\Omega = 2.64 \text{ k}\Omega \quad (25)$$

Select the standard value of 2.7 k Ω .

NOTE

The tolerance of the R_{VSFB1} and R_{VSFB2} resistors in this resistor divider will impact the VSOUT1 regulation and voltage monitoring tolerance. Resistors with 0.1% tolerance are recommended.

For efficiency, the VDD6 preregulator is the supply and therefore the VDD6 output is connected to the VSIN pin. A local, low-ESR 100-nF ceramic capacitor is used on the VSIN pin to stabilize the input.

A local, low-ESR 4.7- μ F ceramic capacitor is used on the VSOUT1 pin for loop stabilization. Depending on the application, this output may require a larger output capacitor to ensure that the output does not drop below the required regulation specification during load transients. The VSOUT1 output capacitance is specified up to 10 μ F.

Figure 6-7 shows this configuration.

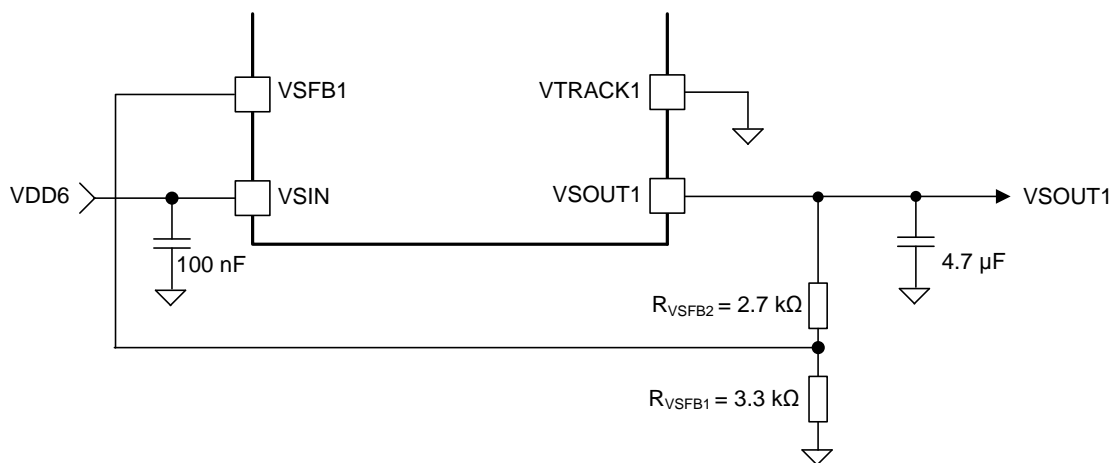

Figure 6-7. VSOUT1 Design—Non-Tracking

6.2.3 Application Curves

For the application curves, see the figures listed in Table 6-1.

Table 6-1. Table of Graphs

FIGURE TITLE	FIGURE NUMBER
SPI SDO Buffer Source and Sink Current	Figure 4-3
VDD6 BUCK Efficiency	Figure 4-4

6.3 System Examples

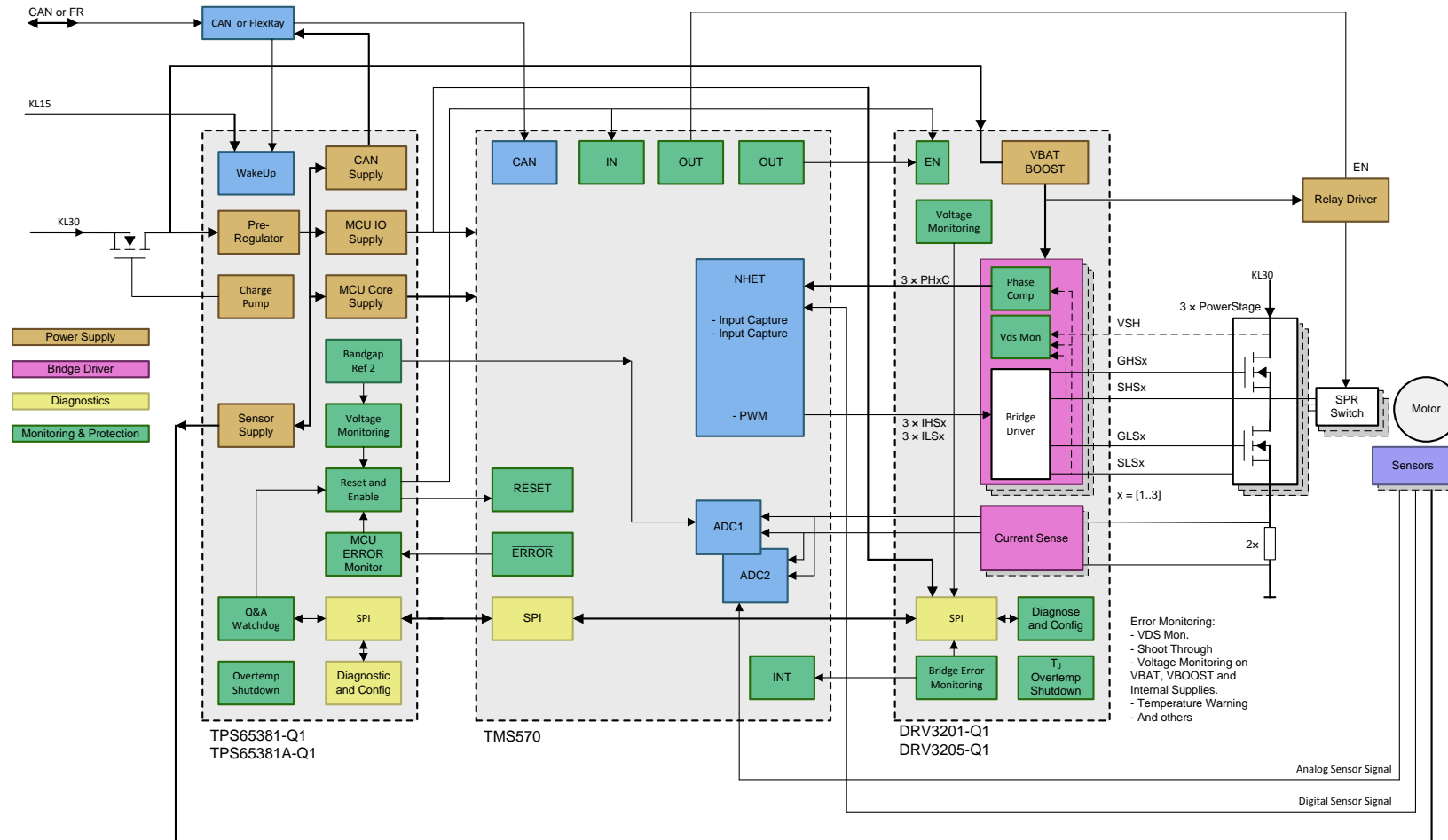

Copyright © 2017, Texas Instruments Incorporated

Figure 6-8. Electrical Power-Steering Example

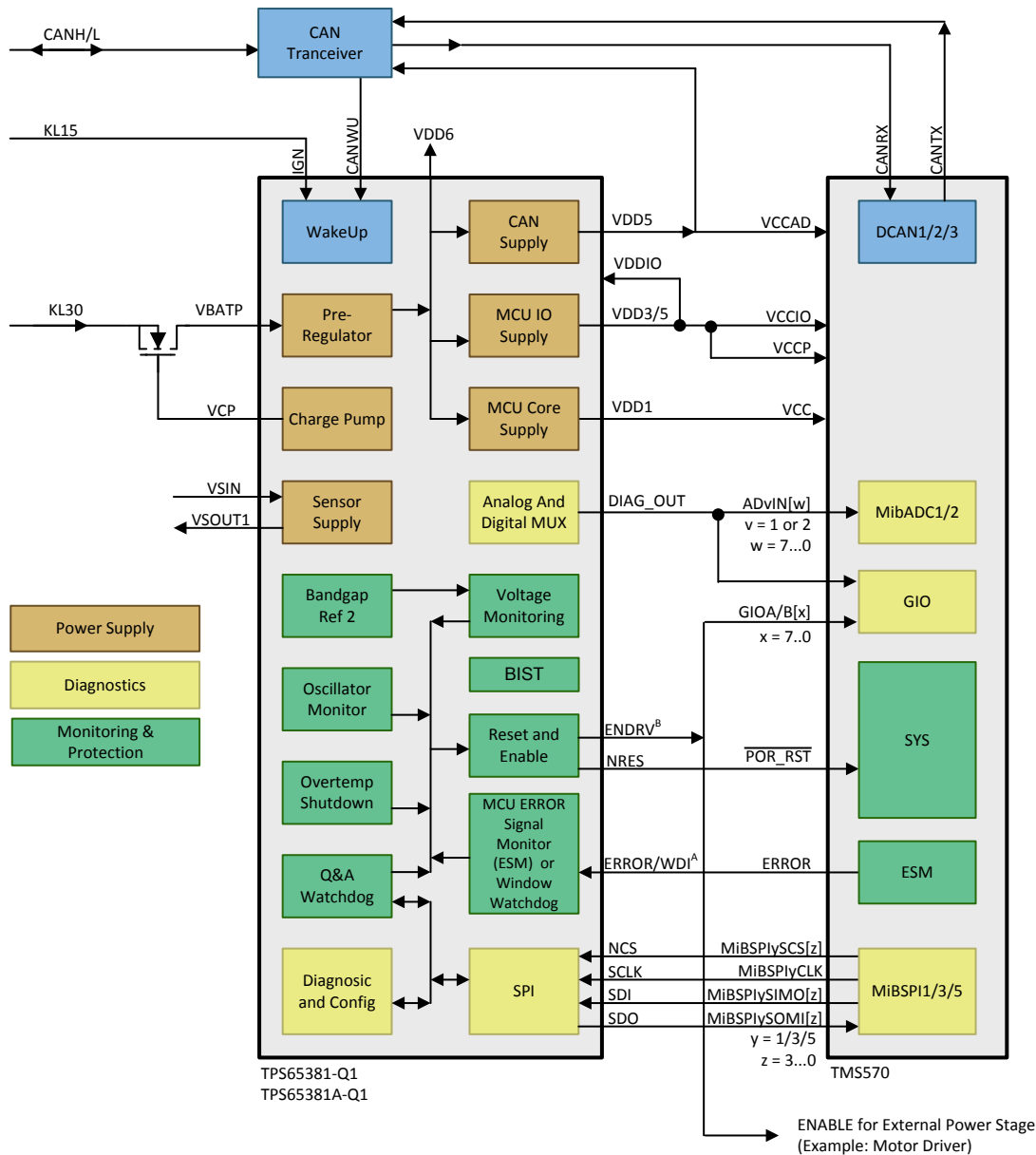

Copyright © 2017, Texas Instruments Incorporated

- A. The ERROR/WDI pin can be configured as an input for the MCU ERROR signal monitor (ESM) (TMS570 dual core or other safety architecture MCU) or as a window watchdog input (TMS470 or other single core MCU).
- B. The ENDRV output can be configured as either as ENABLE for the external power stage (typical use), or optionally as warm-RESET for the TMS570.

Figure 6-9. Example TPS65381A-Q1 With TI's TMS570LS

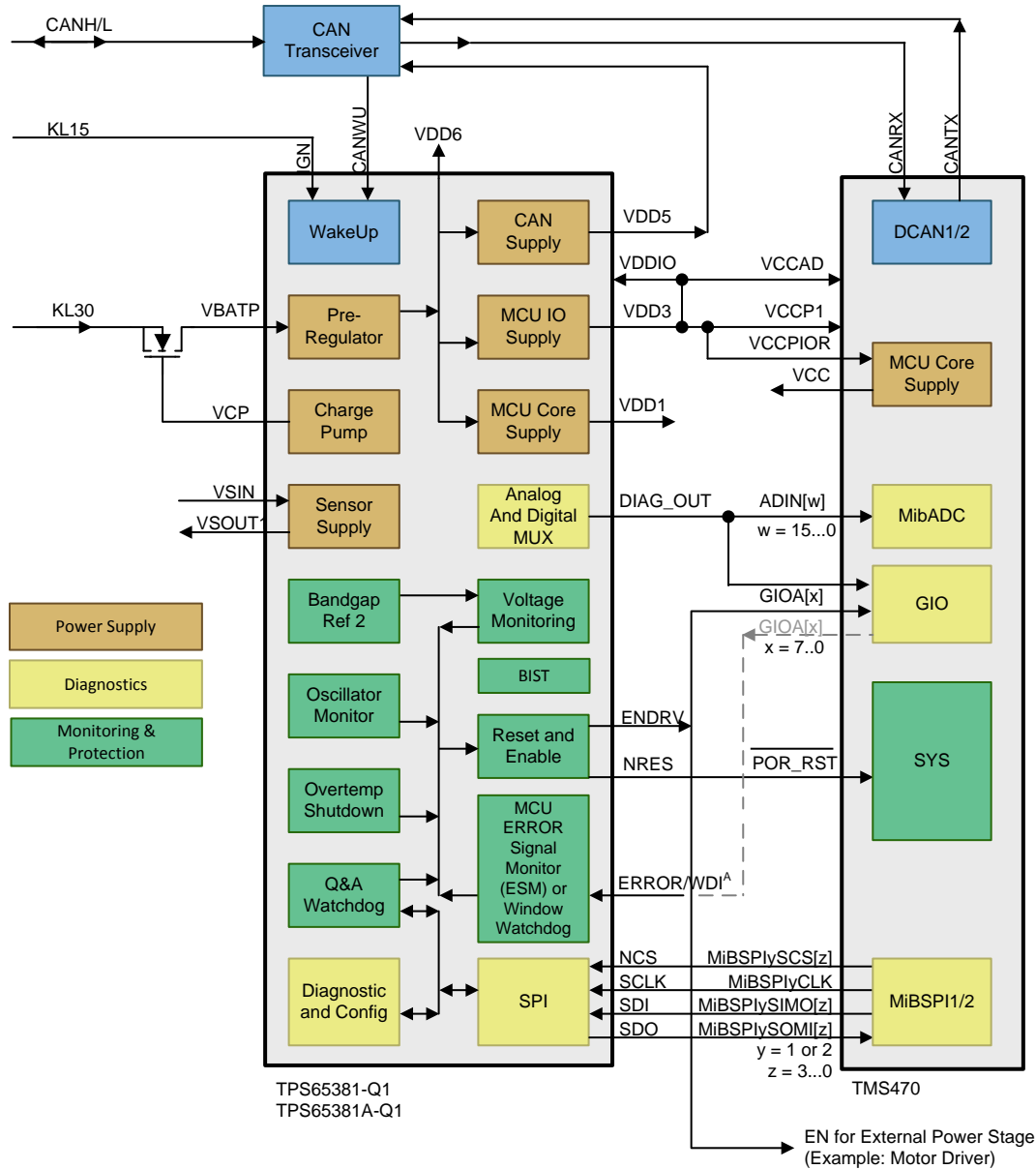

Copyright © 2017, Texas Instruments Incorporated

- A. The ERROR/WDI pin can be configured as an input for the MCU ERROR signal monitor (ESM) (TMS570 dual core or other safety architecture MCU) or as a window watchdog input (TMS470 or other single core MCU).

Figure 6-10. Example TPS65381A-Q1 With TI's TMS470 (Using an Internal MCU Core Supply)

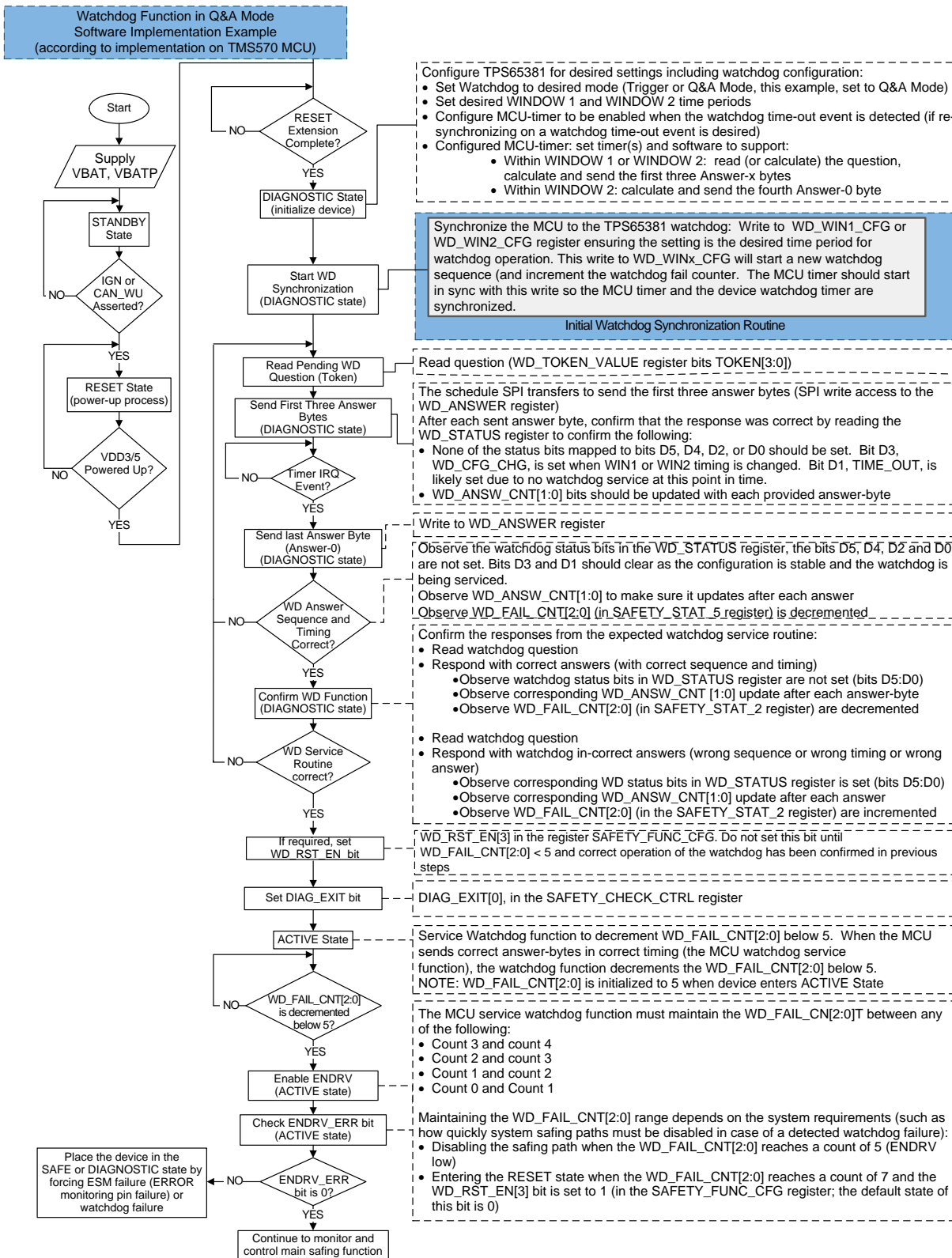

Figure 6-11. Software Flowchart for Configuring and Synchronizing the MCU With the Watchdog in Q&A Mode

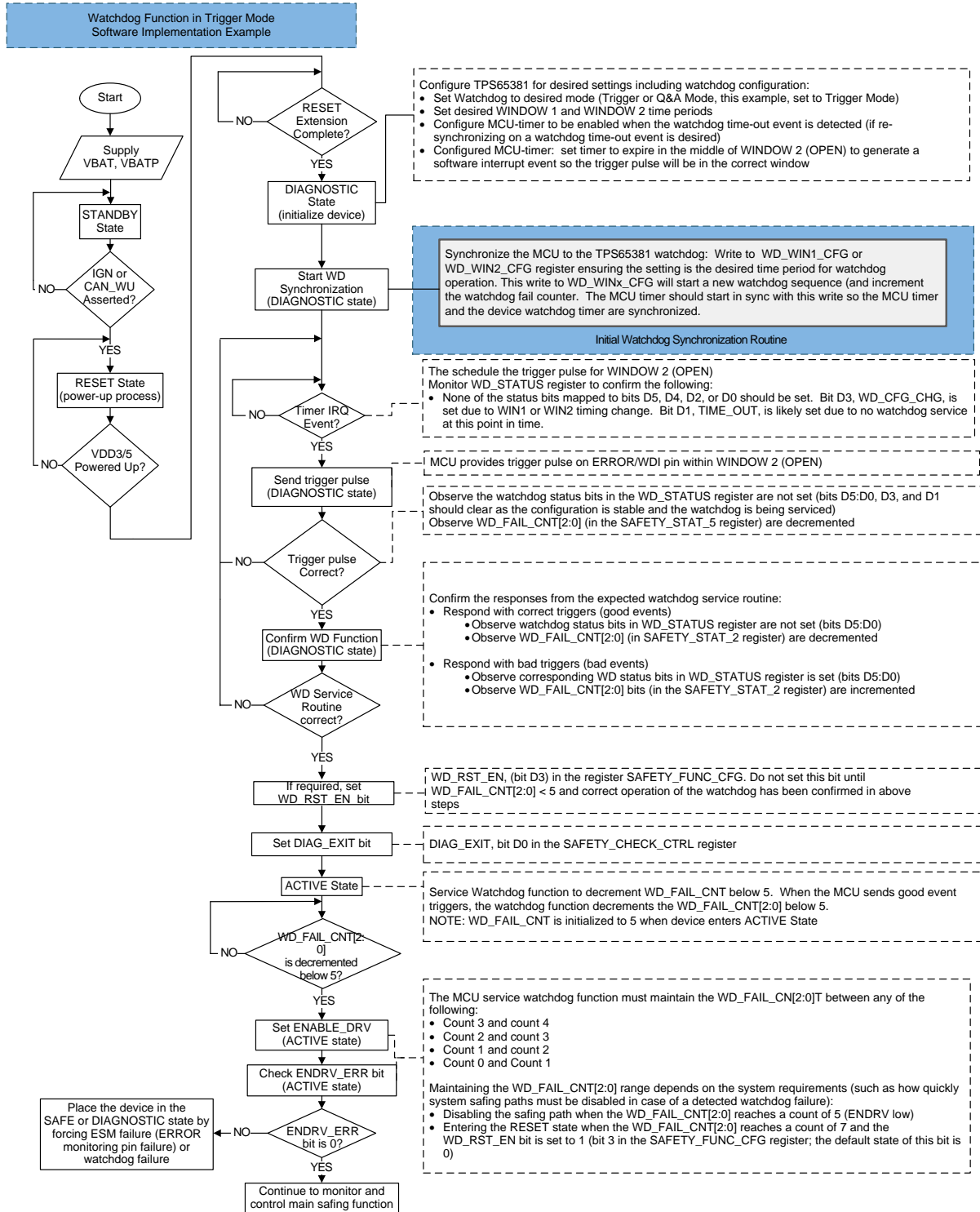

Figure 6-12. Software Flowchart for Configuring and Synchronizing the MCU With the Watchdog in Trigger Mode

7 Power Supply Recommendations

The TPS65381A-Q1 device is designed to operate using an input supply voltage range from 5.8 V to 36 V (CAN, I/O, MCU core, and functional sensor-supply regulators) or 4.5 V to 5.8 V (3.3-V I/O and functional MCU-core voltage). The device has two supply pins: VBATP and VBAT_SAFING. The VBATP pin is the main supply pin for the device. The VBAT_SAFING supply pin is for monitoring (VMON) and BG2 functions. Both the VBATP and VBAT_SAFING supplies must be reverse protected. The VBAT_SAFING pin should be connected to the VBATP pin with a low impedance connection to minimize voltage differences between the device supply pins. For additional power supply recommendations, refer to the [TPS65381EVM User's Guide](#).

8 Layout

8.1 Layout Guidelines

8.1.1 VDD6 Buck Preregulator

- Minimize the loop area for the switching loop of the inductor, ESR resistor, output capacitor, and diode.
- Minimize the parasitic trace impedance by using traces that are as wide as possible.
- Minimize the parasitic via impedance by using multiple vias, especially on high current and switching nodes.
- Connect the inductor and diode to SDN6 as close as possible to the pin.
- Connect the diode to PGND (ground plane).
- Connect the ESR resistor and output capacitor in series between VDD6 output (inductor output) and PGND.
- Connect the EMC filter capacitor between VDD6 output and PGND.
- Connect the VDD6 output to the VDD6 pin with routing to avoid coupling switching noise. Trace length should be minimized and as wide a trace as possible. This trace is the supply input to the downstream regulators using VDD6 as a preregulator, parasitic impedance should be minimized.

Additional consideration: add a footprint for a RC snubber circuit if one is required for the application. The RC connects in-series between the SDN6 and PGND pins.

8.1.2 VDD1 Linear Regulator Controller

- Connect the drain of the external FET to VDD6 node, the trace should be minimized so that additional downstream buffering capacitors are not needed.
- Connect the output capacitor to the source of the external FET, the length of this trace should be minimized. Connect the output capacitor to the ground plane.
- Connect the gate drive, VDD1_G, to the gate of the FET. Connect the resistor between the gate of the FET and the source of the FET, minimize the trace length.
- The resistor divider for sensing and setting the output voltage connects between the source of the FET (VDD1 output) and GND (device signal ground). Do not locate these components and their traces near the switching nodes or high-current traces.

8.1.3 VDD5 and VDD3/5 Linear Regulators

Connect the output capacitor as close as possible between the VDDx output and GND.

8.1.4 VSOUT1 Tracking Linear Regulator

- Connect the output capacitor as close as possible between the VSOUT1 output and GND.
- The resistor divider for sensing and setting the output voltage connects between the VSOUT1 and GND (device signal ground). Do not locate these components and their traces near the switching nodes or high-current traces.
- Connect the local decoupling capacitor between the VSIN and PGND pins. Minimize trace length.
- Route the tracking supply signal, connected to VTRACK1, away from switching nodes or high-current traces.

8.1.5 Charge Pump

- Connect the capacitor as close as possible between the CP1 and CP2 pins.
- Connect the capacitor between the VCP pin and VBATP (reverse protected and filtered) supply.

8.1.6 Other Considerations

- Use ground planes. TI recommends having a solid ground plane and connect GND and PGND with as low impedance paths as possible to the ground plane.
- Minimize parasitic impedance on the critical switching and high current paths.
- Short PGNDx and GND to the thermal pad.
- Use a star ground configuration if connecting to a non-ground plane system. Use tie-ins for the voltage-sense feedback ground and local biasing bypass capacitor ground networks to this star ground.
- Connect the local decoupling capacitor between VBATP and PGND. Minimize trace length.

8.2 Layout Example

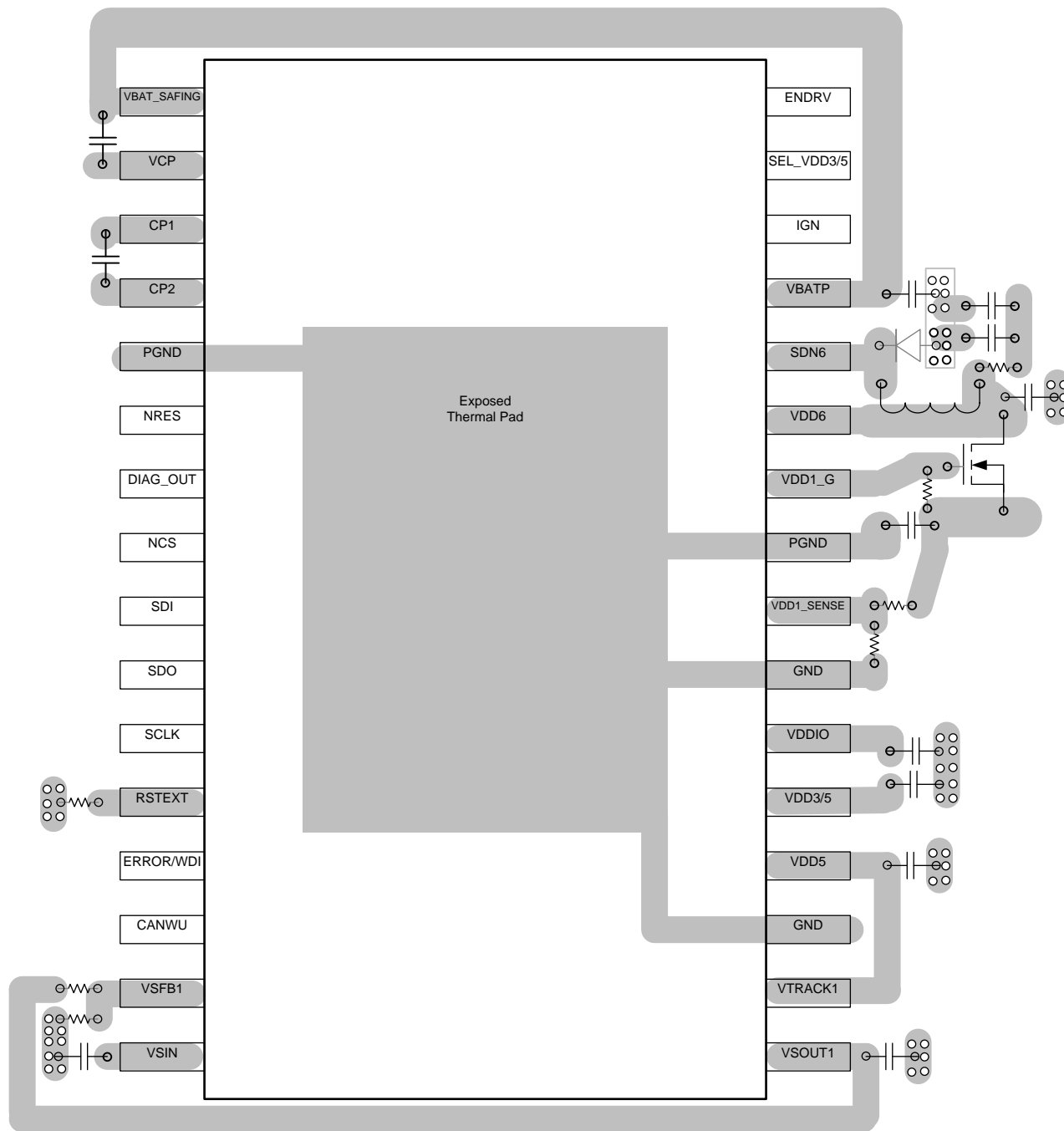

Figure 8-1. TPS65381A-Q1 Board Layout

8.3 Power Dissipation and Thermal Considerations

The power dissipation of the device in the application has significant impact on the necessary layout and thermal management strategy of the application.

Use the following equations to calculate the estimated power dissipation in the device:

$$P_{VDD6} = (1 - \text{eff}_{VDD6}) \times 6 \text{ V} \times I_{VDD6}$$

where

- P_{VDD6} is a conservative estimation of the power dissipation of VDD6 in the device because some of the efficiency loss is externally in the diode and inductor. A more accurate power estimator is available in the [TPS65381-Q1 and TPS65381A-Q1 Power Estimator](#).
- eff_{VDD6} is the efficiency of VDD6 buck preregulator according to [Figure 8-2](#).
- I_{VDD6} is the total load current from VDD5, VDD3/5, VDD1, VSOUT1 and any external load connected to VDD6. (26)

$$P_{VDD5} = (6 \text{ V} - 5 \text{ V}) \times I_{VDD5} = 1 \text{ V} \times I_{VDD5}$$

where

- I_{VDD5} is the load current on VDD5. (27)

$$P_{VDD3/5} = (6 \text{ V} - V_{VDD3/5}) \times I_{VDD3/5}$$

where

- $V_{VDD3/5}$ is either 3.3 V or 5 V.
- $I_{VDD3/5}$ is the load current on VDD3/5. (28)

$$P_{VSOUT1} = (V_{VSIN} - V_{VSOUT1}) \times I_{VSOUT1}$$

where

- V_{VSIN} is either 6 V (VDD6) or VBATP.
- V_{VSOUT1} is the programmed output voltage of VSOUT1.
- I_{VSOUT1} is the load current on VSOUT1 (29)

$$P_{TOT} = P_{VDD6} + P_{VDD5} + P_{VDD3/5} + P_{VSOUT1}$$

where

- P_{TOT} is the total power dissipation in the device. (30)

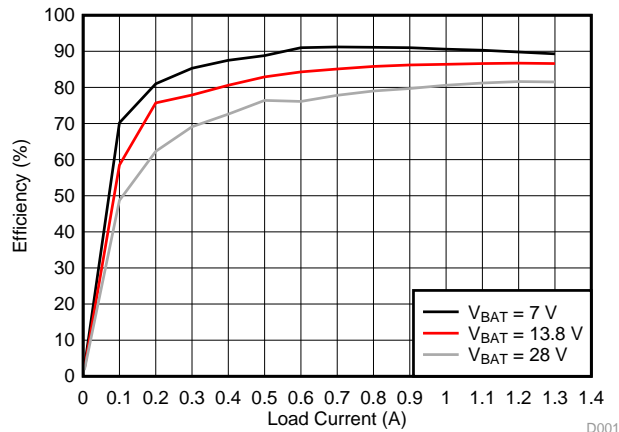

Figure 8-2. Typical VDD6 BUCK Efficiency

The useful range of device operation is affected by the supply voltage, application load-current requirements, and the thermal characteristics of the package and printed circuit board (PCB). For the device to be useful over a wide temperature range, the package, PCB and thermal management strategy must allow for the effective removal of the produce heat to keep junction temperature of the device within rated limits.

Use Equation 26 to Equation 30 to calculate the estimated power dissipation. As shown by the equation for VDD6 power dissipation (PVDD6), Equation 27, a large portion of the power dissipation is determined by the efficiency of the VDD6 supply. The efficiency of the VDD6 supply depends on load current and supply voltage as shown in Equation 27.

The 32-pin HTSSOP PowerPAD (DAP) offers an effective means of removing heat from the device junction. As described in *PowerPad™ Thermally Enhanced Package*, the PowerPAD package offers a lead-frame die pad that is exposed at the base of the package. This thermal pad must be soldered to the copper on the PCB directly underneath the package to create an effective path for removal of heat from the device, and, therefore, to reduce the $R_{\theta JC}$. The PCB must be designed with thermal lands and thermal vias to complete the heat removal subsystem, as summarized in *PowerPAD™ Made Easy* and *A Guide to Board Layout for Best Thermal Resistance for Exposed Packages*.

Figure 8-3 shows the thermal derating profile of the 32-pin HTSSOP (DCA) Package With PowerPAD according to $R_{\theta JA}$ as specified in Section 4.4.

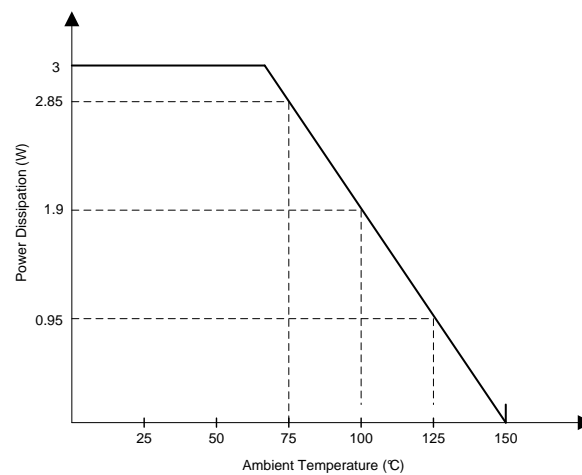

- A. In applications where high power dissipation and/or poor package thermal resistance is present, the maximum ambient temperature may have to be derated. Maximum ambient temperature (T_{Amax}) is dependent on the maximum-operating junction temperature (T_{Jmax}), the maximum power dissipation of the device in the application (P_{Dmax}), and the junction-to-ambient thermal resistance of the part/package in the application ($R_{\theta JA}$), as given by the following equation: $T_{Amax} = T_{Jmax} - (R_{\theta JA} \times P_{Dmax})$.
- B. Maximum power dissipation is a function of T_{Jmax} , $R_{\theta JA}$, and T_A . The maximum-allowable power dissipation at any allowable ambient temperature is $P_D = (T_{Jmax} - T_A) / R_{\theta JA}$.

Figure 8-3. Derating Profile for Power Dissipation Based on High-K JEDEC PCB

Considering the power dissipation of the device in the specific application is important, which is highly dependent on the supply voltage and load currents, the ambient and board temperatures, and any additional heat sink or cooling strategies necessary to maintain the junction temperature of the device below the maximum junction temperature of 150°C.

NOTE

The VDD1 regulator may have significant power dissipation in the external FET depending on the VDD1 voltage and load current. The external FET power dissipation for the VDD1 regulator must be considered in system-level thermal analysis. If better efficiency or thermal performance is needed, a DC-DC regulator could be used instead of the linear regulator controller with external FET. The output voltage of the DC-DC regulator can still be monitored by the VDD1_SENSE pin similar to the VDD1 output voltage when the VDD1 linear regulator controller is used with an external FET.

NOTE

The PowerPAD thermal pad is not directly connected to any leads of the package. However, it is electrically and thermally connected to the substrate, which is the ground (GND) and power ground (PGND) of the device.

NOTE

Additional information about thermal analysis and design can be found on www.ti.com in the [WEBENCH® Design Center](#) thermal analysis section.

9 デバイスおよびドキュメントのサポート**9.1 ドキュメントのサポート****9.1.1 関連資料**

関連資料については、以下を参照してください。

- 『VBATのランプアップおよびランプダウンが低速な場合のデバイス動作』
- 『TPS65381-Q1のDPI評価』
- 『TPS65381-Q1の効率評価』
- 『TPS65381-Q1およびTPS65381A-Q1マルチレール電源用セーフティ・マニュアル』
- 『TPS65381EVMユーザー・ガイド』
- 『TPS65381-Q1およびTPS65381A-Q1デザイン・チェックリスト』
- 『TPS65381-Q1およびTPS65381A-Q1の電力見積もりツール』

9.2 ドキュメントの更新通知を受け取る方法

ドキュメントの更新についての通知を受け取るには、ti.comのデバイス製品フォルダを開いてください。右上の隅にある「通知を受け取る」をクリックして登録すると、変更されたすべての製品情報に関するダイジェストを毎週受け取れます。変更の詳細については、修正されたドキュメントに含まれている改訂履歴をご覧ください。

9.3 Community Resources

The following links connect to TI community resources. Linked contents are provided "AS IS" by the respective contributors. They do not constitute TI specifications and do not necessarily reflect TI's views; see TI's [Terms of Use](#).

TI E2E™ Online Community The TI engineer-to-engineer (E2E) community was created to foster collaboration among engineers. At e2e.ti.com, you can ask questions, share knowledge, explore ideas and help solve problems with fellow engineers.

Design Support TI's Design Support Quickly find helpful E2E forums along with design support tools and contact information for technical support.

9.4 商標

Hercules, C2000, PowerPAD, E2E are trademarks of Texas Instruments.
All other trademarks are the property of their respective owners.

9.5 静電気放電に関する注意事項

すべての集積回路は、適切なESD保護方法を用いて、取扱いと保存を行うようにして下さい。

静電気放電はわずかな性能の低下から完全なデバイスの故障に至るまで、様々な損傷を与えます。高精度の集積回路は、損傷に対して敏感であり、極めてわずかなパラメータの変化により、デバイスに規定された仕様に適合しなくなる場合があります。

9.6 Glossary

TI Glossary This glossary lists and explains terms, acronyms, and definitions.

10 メカニカル、パッケージ、および注文情報

以降のページには、メカニカル、パッケージ、および注文に関する情報が記載されています。これらの情報は、指定のデバイスに対して提供されている最新のデータです。このデータは予告なく変更されることがあり、ドキュメントが改訂される場合もあります。本データシートのブラウザ版を使用されている場合は、画面左側の説明をご覧ください。

PACKAGING INFORMATION

Orderable Device	Status (1)	Package Type	Package Drawing	Pins	Package Qty	Eco Plan (2)	Lead finish/ Ball material (6)	MSL Peak Temp (3)	Op Temp (°C)	Device Marking (4/5)	Samples
TPS65381AQDAPRQ1	ACTIVE	HTSSOP	DAP	32	2000	RoHS & Green	NIPDAU	Level-3-260C-168 HR	-40 to 125	TPS65381A	Samples
TPS65381AQDAPTQ1	ACTIVE	HTSSOP	DAP	32	250	RoHS & Green	NIPDAU	Level-3-260C-168 HR	-40 to 125	TPS65381A	Samples

(1) The marketing status values are defined as follows:

ACTIVE: Product device recommended for new designs.

LIFEBUY: TI has announced that the device will be discontinued, and a lifetime-buy period is in effect.

NRND: Not recommended for new designs. Device is in production to support existing customers, but TI does not recommend using this part in a new design.

PREVIEW: Device has been announced but is not in production. Samples may or may not be available.

OBSOLETE: TI has discontinued the production of the device.

(2) **RoHS:** TI defines "RoHS" to mean semiconductor products that are compliant with the current EU RoHS requirements for all 10 RoHS substances, including the requirement that RoHS substance do not exceed 0.1% by weight in homogeneous materials. Where designed to be soldered at high temperatures, "RoHS" products are suitable for use in specified lead-free processes. TI may reference these types of products as "Pb-Free".

RoHS Exempt: TI defines "RoHS Exempt" to mean products that contain lead but are compliant with EU RoHS pursuant to a specific EU RoHS exemption.

Green: TI defines "Green" to mean the content of Chlorine (Cl) and Bromine (Br) based flame retardants meet JS709B low halogen requirements of <=1000ppm threshold. Antimony trioxide based flame retardants must also meet the <=1000ppm threshold requirement.

(3) MSL, Peak Temp. - The Moisture Sensitivity Level rating according to the JEDEC industry standard classifications, and peak solder temperature.

(4) There may be additional marking, which relates to the logo, the lot trace code information, or the environmental category on the device.

(5) Multiple Device Markings will be inside parentheses. Only one Device Marking contained in parentheses and separated by a "~" will appear on a device. If a line is indented then it is a continuation of the previous line and the two combined represent the entire Device Marking for that device.

(6) Lead finish/Ball material - Orderable Devices may have multiple material finish options. Finish options are separated by a vertical ruled line. Lead finish/Ball material values may wrap to two lines if the finish value exceeds the maximum column width.

Important Information and Disclaimer:The information provided on this page represents TI's knowledge and belief as of the date that it is provided. TI bases its knowledge and belief on information provided by third parties, and makes no representation or warranty as to the accuracy of such information. Efforts are underway to better integrate information from third parties. TI has taken and continues to take reasonable steps to provide representative and accurate information but may not have conducted destructive testing or chemical analysis on incoming materials and chemicals. TI and TI suppliers consider certain information to be proprietary, and thus CAS numbers and other limited information may not be available for release.

In no event shall TI's liability arising out of such information exceed the total purchase price of the TI part(s) at issue in this document sold by TI to Customer on an annual basis.

TAPE AND REEL INFORMATION

QUADRANT ASSIGNMENTS FOR PIN 1 ORIENTATION IN TAPE

*All dimensions are nominal

Device	Package Type	Package Drawing	Pins	SPQ	Reel Diameter (mm)	Reel Width W1 (mm)	A0 (mm)	B0 (mm)	K0 (mm)	P1 (mm)	W (mm)	Pin1 Quadrant
TPS65381AQDAPRQ1	HTSSOP	DAP	32	2000	330.0	24.4	8.6	11.5	1.6	12.0	24.0	Q1
TPS65381AQDAPTQ1	HTSSOP	DAP	32	250	180.0	24.4	8.6	11.5	1.6	12.0	24.0	Q1

TAPE AND REEL BOX DIMENSIONS

*All dimensions are nominal

Device	Package Type	Package Drawing	Pins	SPQ	Length (mm)	Width (mm)	Height (mm)
TPS65381AQDAPRQ1	HTSSOP	DAP	32	2000	350.0	350.0	43.0
TPS65381AQDAPTQ1	HTSSOP	DAP	32	250	213.0	191.0	55.0

GENERIC PACKAGE VIEW

DAP 32

PowerPAD™ TSSOP - 1.2 mm max height

8.1 x 11, 0.65 mm pitch

PLASTIC SMALL OUTLINE

This image is a representation of the package family, actual package may vary.
Refer to the product data sheet for package details.

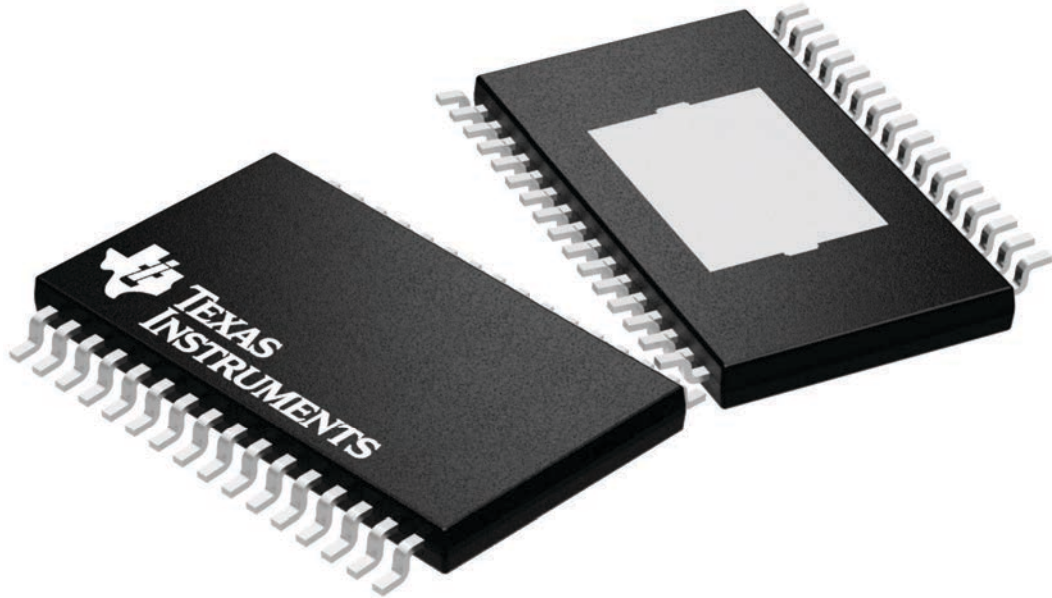

4225303/A

DAP0032B

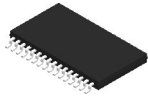

PACKAGE OUTLINE

PowerPAD™ TSSOP - 1.2 mm max height

PLASTIC SMALL OUTLINE

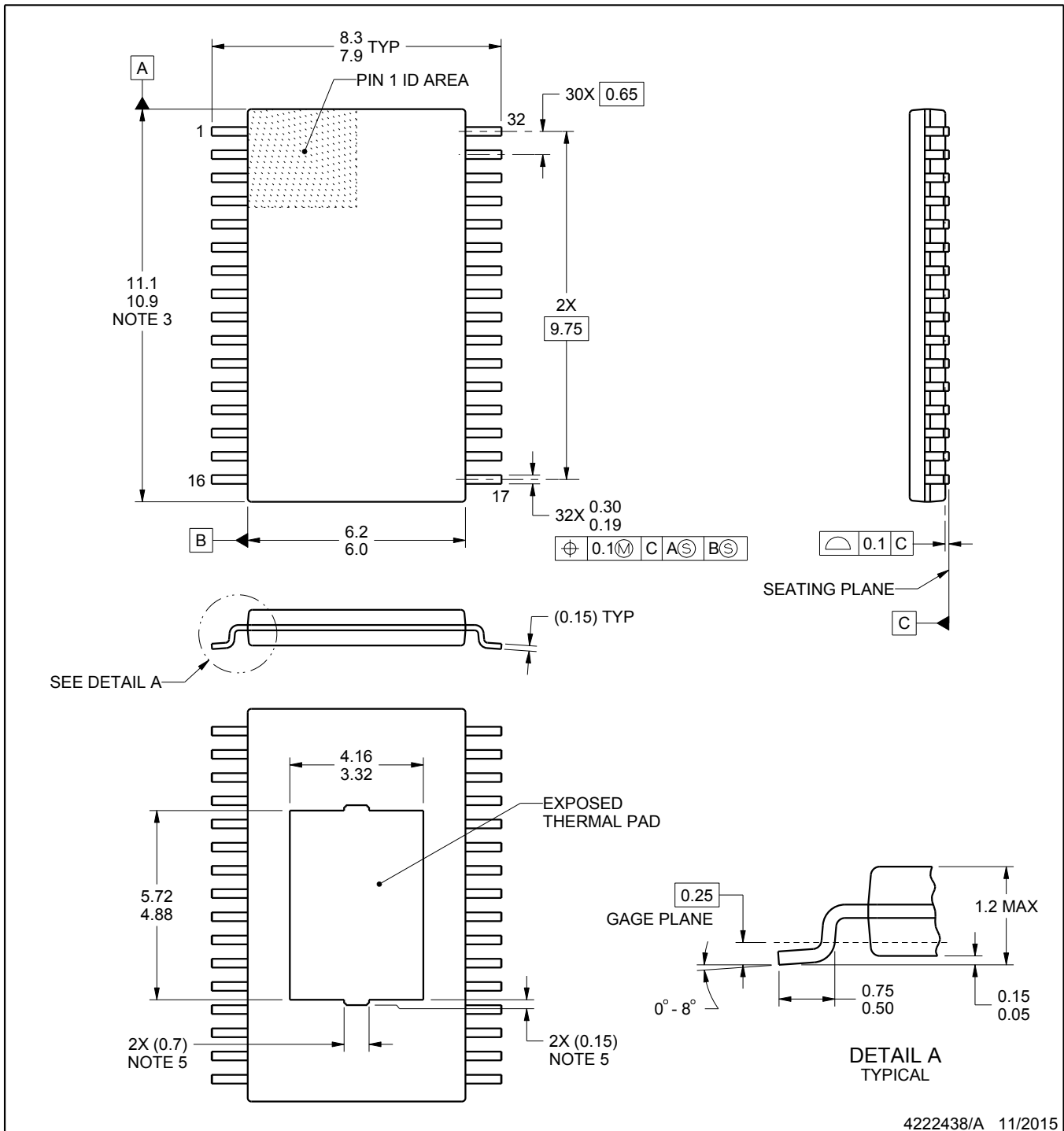

4222438/A 11/2015

NOTES:

PowerPAD is a trademark of Texas Instruments.

1. All linear dimensions are in millimeters. Any dimensions in parenthesis are for reference only. Dimensioning and tolerancing per ASME Y14.5M.
2. This drawing is subject to change without notice.
3. This dimension does not include mold flash, protrusions, or gate burrs. Mold flash, protrusions, or gate burrs shall not exceed 0.15 mm per side.
4. Reference JEDEC registration MO-153, variation DCT.
5. Features may not present.

EXAMPLE BOARD LAYOUT

DAP0032B

PowerPAD™ TSSOP - 1.2 mm max height

PLASTIC SMALL OUTLINE

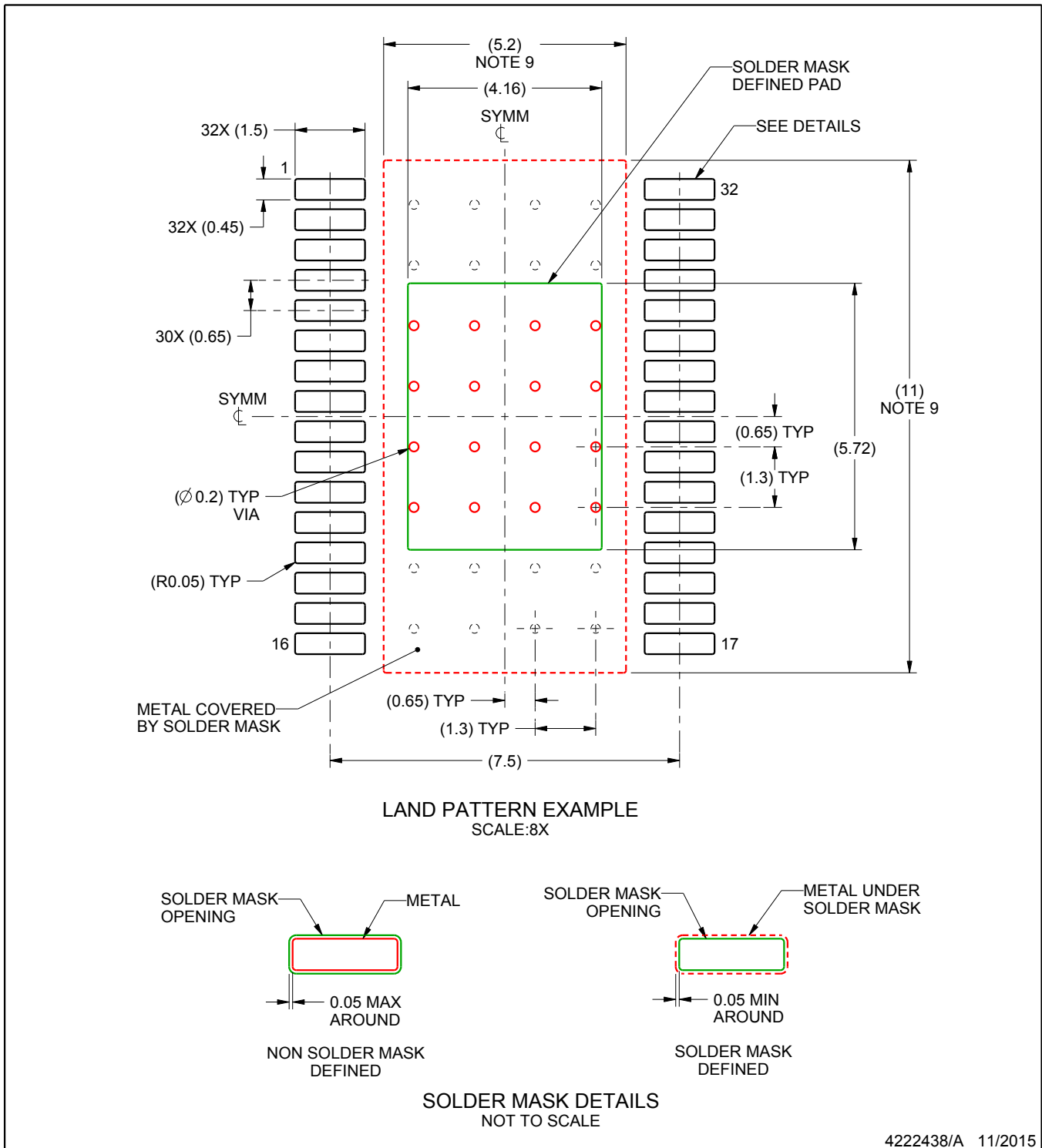

4222438/A 11/2015

NOTES: (continued)

6. Publication IPC-7351 may have alternate designs.
7. Solder mask tolerances between and around signal pads can vary based on board fabrication site.
8. This package is designed to be soldered to a thermal pad on the board. For more information, see Texas Instruments literature numbers SLMA002 (www.ti.com/lit/slma002) and SLMA004 (www.ti.com/lit/slma004).
9. Size of metal pad may vary due to creepage requirement.

EXAMPLE STENCIL DESIGN

DAP0032B

PowerPAD™ TSSOP - 1.2 mm max height

PLASTIC SMALL OUTLINE

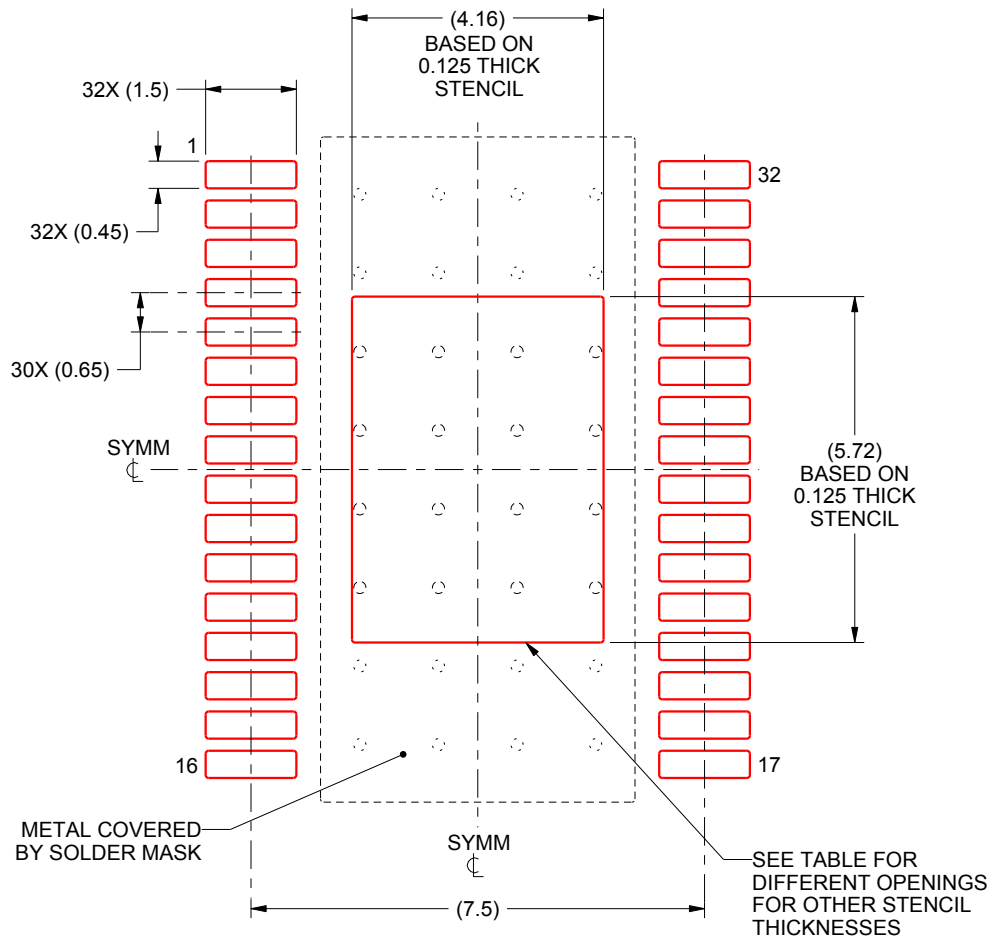

SOLDER PASTE EXAMPLE
 EXPOSED PAD
 100% PRINTED SOLDER COVERAGE BY AREA
 SCALE:8X

STENCIL THICKNESS	SOLDER STENCIL OPENING
0.1	4.65 X 6.4
0.125	4.16 X 5.72 (SHOWN)
0.15	3.8 X 5.22
0.175	3.52 X 4.83

4222438/A 11/2015

NOTES: (continued)

- 10. Laser cutting apertures with trapezoidal walls and rounded corners may offer better paste release. IPC-7525 may have alternate design recommendations.
- 11. Board assembly site may have different recommendations for stencil design.

重要なお知らせと免責事項

TI は、技術データと信頼性データ（データシートを含みます）、設計リソース（リファレンス・デザインを含みます）、アプリケーションや設計に関する各種アドバイス、Web ツール、安全性情報、その他のリソースを、欠陥が存在する可能性のある「現状のまま」提供しており、商品性および特定目的に対する適合性の黙示保証、第三者の知的財産権の非侵害保証を含むいかなる保証も、明示的または黙示的にかかわらず拒否します。

これらのリソースは、TI 製品を使用する設計の経験を積んだ開発者への提供を意図したものです。(1) お客様のアプリケーションに適した TI 製品の選定、(2) お客様のアプリケーションの設計、検証、試験、(3) お客様のアプリケーションに該当する各種規格や、その他のあらゆる安全性、セキュリティ、規制、または他の要件への確実な適合に関する責任を、お客様のみが単独で負うものとし、

上記の各種リソースは、予告なく変更される可能性があります。これらのリソースは、リソースで説明されている TI 製品を使用するアプリケーションの開発の目的でのみ、TI はその使用をお客様に許諾します。これらのリソースに関して、他の目的で複製することや掲載することは禁止されています。TI や第三者の知的財産権のライセンスが付与されている訳ではありません。お客様は、これらのリソースを自身で使用した結果発生するあらゆる申し立て、損害、費用、損失、責任について、TI およびその代理人を完全に補償するものとし、TI は一切の責任を拒否します。

TI の製品は、[TI の販売条件](#)、または [ti.com](#) やかかる TI 製品の関連資料などのいずれかを通じて提供する適用可能な条項の下で提供されています。TI がこれらのリソースを提供することは、適用される TI の保証または他の保証の放棄の拡大や変更を意味するものではありません。

お客様がいかなる追加条項または代替条項を提案した場合でも、TI はそれらに異議を唱え、拒否します。

郵送先住所：Texas Instruments, Post Office Box 655303, Dallas, Texas 75265
Copyright © 2024, Texas Instruments Incorporated