

TPA3244 60Wステレオ、110Wピーク、PurePath™ Ultra HDパッド・ダウンClass-Dアンプ

1 特長

- 差動アナログ入力
- 10%THD+N時の総出力電力
 - BTL構成、30Vで8Ωへステレオ、連続的に60W
 - BTL構成、30Vで4Ωへステレオ、ピーク110W
- 1%THD+N時の総出力電力
 - BTL構成、30Vで8Ωへステレオ、連続的に50W
 - BTL構成、30Vで4Ωへステレオ、ピーク90W
- 高度な統合フィードバック設計と、高速なゲート・ドライバ・エラー訂正
 - (PurePath™ Ultra-HD)
 - 最高100kHzの信号帯域幅によりHDソースからの高周波数のコンテンツに対応
 - 非常に低いTHD+N: 4Ω〜1Wで0.005%、クリッピング〜0.01%未満
 - 60dB PSRR (BTL、入力信号なし)
 - 出力ノイズ55μV未満(Aウェイト)
 - SNR 110dB超(Aウェイト)
- 複数の構成が可能:
 - ステレオ、モノラル、2.1、4xSE
- 開始時と停止時にクリック音やポップ音が発生しない
- 94%効率のClass-D動作(8Ω)
- 12V〜30Vの広い電源電圧範囲での動作
- 自己保護設計(低電圧、過熱、クリッピング、短絡保護を含む)とエラー報告機能
- 推奨システム設計で使用時にEMI準拠

2 アプリケーション

- ハイエンド・サウンドバー
- ミニ・コンボ・システム
- Blu-Ray Disc™/ DVDレシーバ
- アクティブ・スピーカ

3 概要

TPA3244デバイスは高性能のClass-Dパワー・アンプで、最高のサウンド品質をClass-Dの効率で実現します。高度な統合フィードバック設計と、独自の高速ゲート・ドライバ・エラー訂正機能(PurePath™ Ultra-HD)があります。このテクノロジーにより、音声帯域全体にわたる歪みが非常に低い、優れたオーディオ品質を実現しています。このデバイスは30V電源により、4Ω負荷へ2×110Wのピーク、および8Ω負荷へ2×60Wの連続出力を駆動でき、2つのVRMSアナログ入力インターフェイスが搭載され、TIのBurr-Brown PCM52xx DACファミリ(PCM5242/PCM5252)などの高性能DACとシームレスに動作します。優れたオーディオ性能に加えて、TPA3244は高い出力効率を達成し、電力段でのアイドル損失が0.45W未満と非常に低くなっています。これらは、65mΩ MOSFETの使用と、最適化されたゲート・ドライバ方式で、一般的なディスクリート実装よりも大幅に低いアイドル損失を実現することにより達成されています。

製品情報⁽¹⁾

型番	パッケージ	本体サイズ(公称)
TPA3244	HTSSOP (44)	6.10mmx14.00mm

(1) 提供されているすべてのパッケージについては、巻末の注文情報を参照してください。

概略回路図

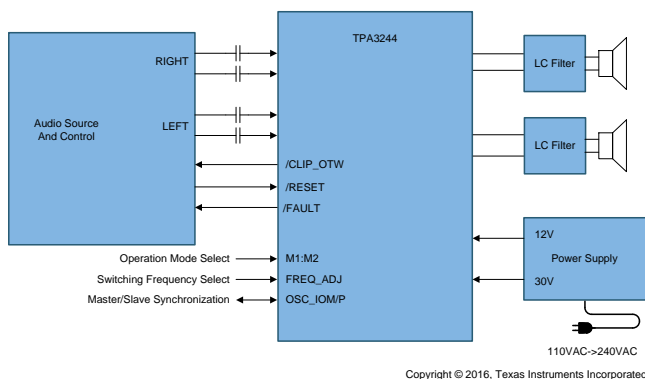

Copyright © 2016, Texas Instruments Incorporated

全高調波歪み

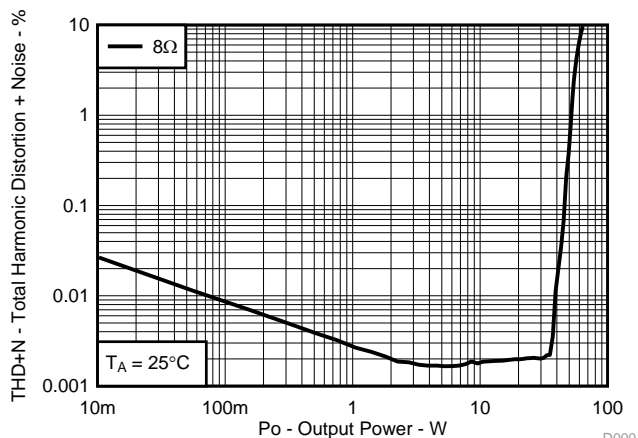

D000



目次

1	特長	1	9.4	Device Functional Modes	17
2	アプリケーション	1	10	Application and Implementation	22
3	概要	1	10.1	Application Information	22
4	改訂履歴	2	10.2	Typical Applications	22
5	Device Comparison Table	3	10.3	Typical Application, Differential (2N), PBTL (Outputs Paralleled after LC filter)	30
6	Pin Configuration and Functions	3	11	Power Supply Recommendations	32
7	Specifications	5	11.1	Power Supplies	32
7.1	Absolute Maximum Ratings	5	11.2	Powering Up	32
7.2	ESD Ratings	5	11.3	Powering Down	33
7.3	Recommended Operating Conditions	6	11.4	Thermal Design	34
7.4	Thermal Information	6	12	Layout	37
7.5	Electrical Characteristics	7	12.1	Layout Guidelines	37
7.6	Audio Characteristics (BTL)	8	12.2	Layout Examples	38
7.7	Audio Characteristics (SE)	9	13	デバイスおよびドキュメントのサポート	42
7.8	Audio Characteristics (PBTL)	9	13.1	ドキュメントのサポート	42
7.9	Typical Characteristics	10	13.2	ドキュメントの更新通知を受け取る方法	42
8	Parameter Measurement Information	14	13.3	コミュニティ・リソース	42
9	Detailed Description	14	13.4	商標	42
9.1	Overview	14	13.5	静電気放電に関する注意事項	42
9.2	Functional Block Diagrams	15	13.6	Glossary	42
9.3	Feature Description	17	14	メカニカル、パッケージ、および注文情報	42

4 改訂履歴

資料番号末尾の英字は改訂を表しています。その改訂履歴は英語版に準じています。

2016年4月発行のものから更新

	Page
• プレビューから量産データへ変更	1
• Changed pin 18 From: INPUT_B To: INPUT_A in the <i>Pin Functions</i> table	4
• Changed pin 17 From: INPUT_A To: INPUT_B in the <i>Pin Functions</i> table	4
• Changed Figure 23	22
• Changed Figure 24	26
• Changed Figure 25	28

5 Device Comparison Table

DEVICE NAME	DESCRIPTION
TPA3245	100-W Stereo, 200-W Mono PurePath™ Ultra-HD Analog-Input Class-D Amplifier
TPA3250	70-W Stereo, 130-W peak PurePath™ Ultra-HD Pad Down Class-D Amplifier
TPA3251	175-W Stereo, 350-W Mono PurePath™ Ultra-HD Analog-Input Class-D Amplifier
TPA3255	315-W Stereo, 600-W Mono PurePath™ Ultra-HD Analog-Input Class-D Amplifier

6 Pin Configuration and Functions

The TPA3244 device is available in a thermally enhanced TSSOP package.

The package type contains a PowerPad™ that is located on the bottom side of the device for thermal connection to the PCB.

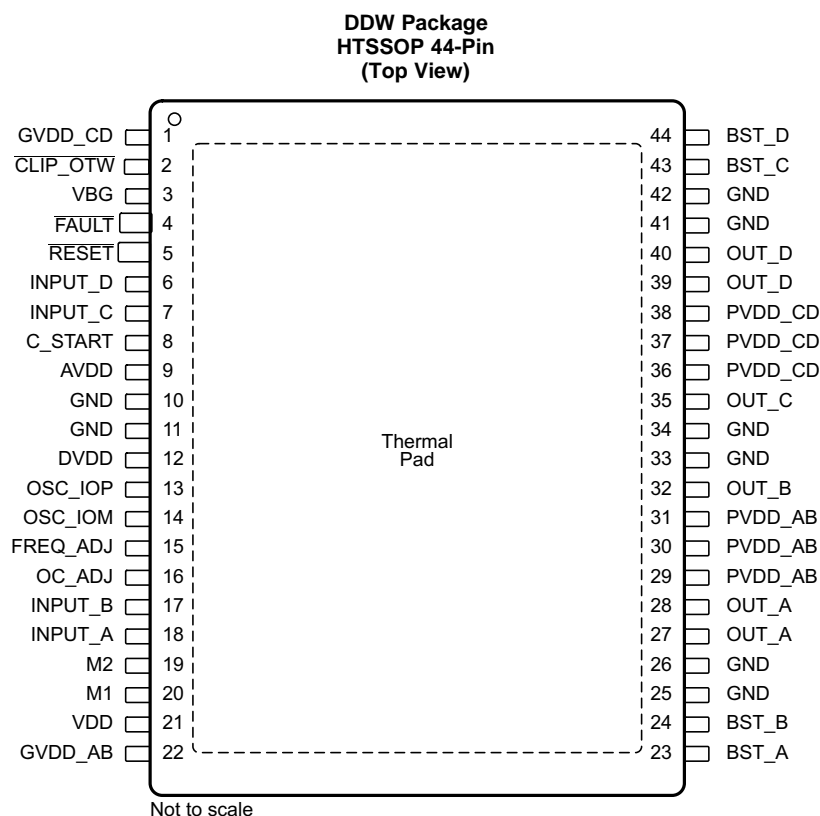

Pin Functions

PIN		I/O	DESCRIPTION
NAME	NO.		
AVDD	9	P	Internal voltage regulator, analog section
BST_A	23	P	HS bootstrap supply (BST), external 0.033 μ F capacitor to OUT_A required.
BST_B	24	P	HS bootstrap supply (BST), external 0.033 μ F capacitor to OUT_B required.
BST_C	43	P	HS bootstrap supply (BST), external 0.033 μ F capacitor to OUT_C required.
BST_D	44	P	HS bootstrap supply (BST), external 0.033 μ F capacitor to OUT_D required.
$\overline{\text{CLIP_OTW}}$	2	O	Clipping warning and Over-temperature warning; open drain; active low. Do not connect if not used.
C_START	8	O	Startup ramp, requires a charging capacitor to GND
DVDD	12	P	Internal voltage regulator, digital section
$\overline{\text{FAULT}}$	4	O	Shutdown signal, open drain; active low. Do not connect if not used.
FREQ_ADJ	15	O	Oscillator frequency programming pin
GND	10, 11, 25, 26, 33, 34, 41, 42	P	Ground
GVDD_AB	22	P	Gate-drive voltage supply; AB-side, requires 0.1 μ F capacitor to GND
GVDD_CD	1	P	Gate-drive voltage supply; CD-side, requires 0.1 μ F capacitor to GND
INPUT_A	18	I	Input signal for half bridge A
INPUT_B	17	I	Input signal for half bridge B
INPUT_C	7	I	Input signal for half bridge C
INPUT_D	6	I	Input signal for half bridge D
M1	20	I	Mode selection 1 (LSB)
M2	19	I	Mode selection 2 (MSB)
OC_ADJ	16	I/O	Over-Current threshold programming pin
OSC_IOM	14	I/O	Oscillator synchronization interface. Do not connect if not used.
OSC_IOP	13	O	Oscillator synchronization interface. Do not connect if not used.
OUT_A	27, 28	O	Output, half bridge A
OUT_B	32	O	Output, half bridge B
OUT_C	35	O	Output, half bridge C
OUT_D	39, 40	O	Output, half bridge D
PVDD_AB	29, 30, 31	P	PVDD supply for half-bridge A and B
PVDD_CD	36, 37, 38	P	PVDD supply for half-bridge C and D
$\overline{\text{RESET}}$	5	I	Device reset Input; active low
VDD	21	P	Power supply for internal voltage regulator requires a 10- μ F capacitor with a 0.1- μ F capacitor to GND for decoupling.
VBG	3	P	Internal voltage reference requires a 0.1- μ F capacitor to GND for decoupling.
PowerPAD™		P	Ground, connect to PCB copper pour. Placed on bottom side of device.

Table 1. Mode Selection Pins

MODE PINS ⁽¹⁾		INPUT MODE	OUTPUT CONFIGURATION	DESCRIPTION
M2	M1			
0	0	2N + 1	2 x BTL	Stereo BTL output configuration
0	1	2N/1N + 1	1 x BTL + 2 x SE	2.1 BTL + SE mode. Channel AB: BTL, channel C + D: SE
1	0	2N + 1	1 x PBTL	Paralleled BTL configuration. Connect INPUT_C and INPUT_D to GND.
1	1	1N + 1	4 x SE	Single ended output configuration

(1) 1 refers to logic high (DVDD level), 0 refers to logic low (GND).

7 Specifications

7.1 Absolute Maximum Ratings

over operating free-air temperature range (unless otherwise noted) ⁽¹⁾

		MIN	MAX	UNIT
Supply voltage	BST_X to GVDD_X ⁽²⁾	-0.3	43	V
	VDD to GND	-0.3	13.2	V
	GVDD_X to GND ⁽²⁾	-0.3	13.2	V
	PVDD_X to GND ⁽²⁾	-0.3	43	V
	DVDD to GND	-0.3	4.2	V
	AVDD to GND	-0.3	8.5	V
	VBG to GND	-0.3	4.2	V
Interface pins	OUT_X to GND ⁽²⁾	-0.3	43	V
	BST_X to GND ⁽²⁾	-0.3	55.5	V
	OC_ADJ, M1, M2, OSC_IOP, OSC_IOM, FREQ_ADJ, C_START, to GND	-0.3	4.2	V
	RESET, FAULT, CLIP_OTW, CLIP to GND	-0.3	4.2	V
	INPUT_X to GND	-0.3	7	V
	Continuous sink current, RESET, FAULT, CLIP_OTW, CLIP, RESET to GND		9	mA
T _J	Operating junction temperature range	0	150	°C
T _{stg}	Storage temperature range	-40	150	°C

- (1) Stresses beyond those listed under *Absolute Maximum Ratings* may cause permanent damage to the device. These are stress ratings only, which do not imply functional operation of the device at these or any other conditions beyond those indicated under *Recommended Operating Conditions*. Exposure to absolute-maximum-rated conditions for extended periods may affect device reliability.
- (2) These voltages represents the DC voltage + peak AC waveform measured at the terminal of the device in all conditions.

7.2 ESD Ratings

			VALUE	UNIT
V _{ESD}	Electrostatic discharge	Human body model (HBM), per ANSI/ESDA/JEDEC JS-001, all pins ⁽¹⁾	±1000	V
		Charged device model (CDM), per JEDEC specification JESD22-C101, all pins ⁽²⁾	±250	V

- (1) JEDEC document JEP155 states that 500-V HBM allows safe manufacturing with a standard ESD control process.
- (2) JEDEC document JEP157 states that 250-V CDM allows safe manufacturing with a standard ESD control process.

7.3 Recommended Operating Conditions

over operating free-air temperature range (unless otherwise noted)

			MIN	TYP	MAX	UNIT
PVDD_x	Half-bridge supply	DC supply voltage	12	30	31.5	V
GVDD_x	Supply for logic regulators and gate-drive circuitry	DC supply voltage	10.8	12	13.2	V
VDD	Digital regulator supply voltage	DC supply voltage	10.8	12	13.2	V
R _L (BTL)	Load impedance	Output filter inductance within recommended value range	2.7	4		Ω
R _L (SE)			1.5	3		
R _L (PBTL)			1.6	2		
L _{OUT} (BTL)	Output filter inductance	Minimum output inductance at I _{OC}	5			μH
L _{OUT} (SE)			5			
L _{OUT} (PBTL)			5			
F _{PWM}	PWM frame rate selectable for AM interference avoidance; 1% Resistor tolerance	Nominal	430	450	470	kHz
		AM1	475	500	525	
		AM2	575	600	625	
R _(FREQ_ADJ)	PWM frame rate programming resistor	Nominal; Master mode	29.7	30	30.3	kΩ
		AM1; Master mode	19.8	20	20.2	
		AM2; Master mode	9.9	10	10.1	
C _{PVDD}	PVDD close decoupling capacitors		1.0		μF	
R _{OC}	Over-current programming resistor	Resistor tolerance = 5%	22		30	kΩ
R _{OC} (LATCHED)	Over-current programming resistor	Resistor tolerance = 5%	47		64	kΩ
V _(FREQ_ADJ)	Voltage on FREQ_ADJ pin for slave mode operation	Slave mode		3.3		V
T _J	Junction temperature		0		125	°C

7.4 Thermal Information

THERMAL METRIC ⁽¹⁾		TPA3244			UNIT
		DDV 44-PINS HTSSOP			
		JEDEC STANDARD 4 LAYER PCB			
R _{θJA}	Junction-to-ambient thermal resistance	23.0			°C/W
R _{θJC(top)}	Junction-to-case (top) thermal resistance	9.1			°C/W
R _{θJB}	Junction-to-board thermal resistance	3.9			°C/W
ψ _{JT}	Junction-to-top characterization parameter	0.1			°C/W
ψ _{JB}	Junction-to-board characterization parameter	3.9			°C/W
R _{θJC(bot)}	Junction-to-case (bottom) thermal resistance	0.3			°C/W

(1) For more information about traditional and new thermal metrics, see the [Semiconductor and IC Package Thermal Metrics](#) application report.

7.5 Electrical Characteristics

PVDD_X = 30 V, GVDD_X = 12 V, VDD = 12 V, T_A (Ambient temperature) = 25°C, f_s = 450 kHz, unless otherwise specified.

PARAMETER		TEST CONDITIONS	MIN	TYP	MAX	UNIT
INTERNAL VOLTAGE REGULATOR AND CURRENT CONSUMPTION						
DVDD	Voltage regulator, only used as reference node	VDD = 12 V	3	3.3	3.6	V
AVDD	Voltage regulator, only used as reference node	VDD = 12 V		7.8		V
I _{VDD}	VDD supply current	Operating, 50% duty cycle		40		mA
		Idle, reset mode		13		
I _{GVDD_X}	Gate-supply current per full-bridge	50% duty cycle		15		mA
		Reset mode		2		
I _{PVDD_X}	PVDD idle current per full bridge	50% duty cycle with 10µH Output Filter Inductors		12.5		mA
		Reset mode, No switching		1		
ANALOG INPUTS						
R _{IN}	Input resistance			24		kΩ
V _{IN}	Maximum input voltage swing				7	V
I _{IN}	Maximum input current				1	mA
G	Inverting voltage Gain	V _{OUT} /V _{IN}		20		dB
OSCILLATOR						
f _{OSC(I0+)}	Nominal, Master Mode	F _{PWM} × 6	2.58	2.7	2.82	MHz
	AM1, Master Mode		2.85	3	3.15	
	AM2, Master Mode		3.45	3.6	3.75	
V _{IH}	High level input voltage		1.86			V
V _{IL}	Low level input voltage				1.45	V
OUTPUT-STAGE MOSFETS						
R _{DS(on)}	Drain-to-source resistance, low side (LS)	T _J = 25°C, Includes metallization resistance, GVDD = 12 V		65		mΩ
	Drain-to-source resistance, high side (HS)			65		
I/O PROTECTION						
V _{uwp,VDD,GVDD}	Undervoltage protection limit, GVDD_x and VDD			9.5		V
V _{uwp,VDD, GVDD,hyst} ⁽¹⁾				0.6		V
V _{uwp,PVDD}	Undervoltage protection limit, PVDD_x			10		V
V _{uwp,PVDD,hyst} ⁽¹⁾				0.6		V
OTW	Overtemperature warning, $\overline{\text{CLIP_OTW}}$ ⁽¹⁾		115	125	135	°C
OTW _{hyst} ⁽¹⁾	Temperature drop needed below OTW temperature for $\overline{\text{CLIP_OTW}}$ to be inactive after OTW event.			25		°C
OTE ⁽¹⁾	Overtemperature error		145	155	165	°C
OTE _{hyst} ⁽¹⁾	A reset needs to occur for $\overline{\text{FAULT}}$ to be released following an OTE event			25		°C
OTE-OTW _(differential) ⁽¹⁾	OTE-OTW differential			30		°C
OLPC	Overload protection counter	f _{PWM} = 450 kHz		2.3		ms
I _{OC}	Overcurrent limit protection	Resistor – programmable, nominal peak current in 1Ω load, R _{OCP} = 22 kΩ		14		A
I _{OC(LATCHED)}	Overcurrent limit protection	Resistor – programmable, peak current in 1Ω load, R _{OCP} = 47kΩ		14		A
I _{DCspkr}	DC Speaker Protection Current Threshold	BTL current imbalance threshold		1.5		A
I _{OCT}	Overcurrent response time	Time from switching transition to flip-state induced by overcurrent.		150		ns
I _{PD}	Output pulldown current of each half	Connected when $\overline{\text{RESET}}$ is active to provide bootstrap charge. Not used in SE mode.		3		mA

(1) Specified by design.

Electrical Characteristics (continued)

PVDD_X = 30 V, GVDD_X = 12 V, VDD = 12 V, T_A (Ambient temperature) = 25°C, f_S = 450 kHz, unless otherwise specified.

PARAMETER		TEST CONDITIONS	MIN	TYP	MAX	UNIT
STATIC DIGITAL SPECIFICATIONS						
V _{IH}	High level input voltage	M1, M2, OSC_IOP, OSC_IOM, RESET	1.9			V
V _{IL}	Low level input voltage				0.8	V
I _{ikg}	Input leakage current				100	μA
OTW/SHUTDOWN (FAULT)						
R _{INT_PU}	Internal pullup resistance, CLIP_OTW to DVDD, FAULT to DVDD		20	26	32	kΩ
V _{OH}	High level output voltage	Internal pullup resistor	3	3.3	3.6	V
V _{OL}	Low level output voltage	I _O = 4 mA		200	500	mV
Device fanout	CLIP_OTW, FAULT	No external pullup		30		devices

7.6 Audio Characteristics (BTL)

PCB and system configuration are in accordance with recommended guidelines. Audio frequency = 1 kHz, PVDD_X = 30 V, GVDD_X = 12 V, R_L = 8 Ω, f_S = 450 kHz, R_{OC} = 22 kΩ, T_A = 25°C, Output Filter: L_{DEM} = 10 μH, C_{DEM} = 1 μF, mode = 00, AES17 + AUX-0025 measurement filters, unless otherwise noted.

PARAMETER		TEST CONDITIONS	MIN	TYP	MAX	UNIT
P _O	Power output per channel	R _L = 8 Ω, 10% THD+N		60		W
		R _L = 4 Ω, 10% THD+N, Single Channel, 20 seconds duration ⁽¹⁾		110		
		R _L = 8 Ω, 1% THD+N		50		
		R _L = 4 Ω, 1% THD+N, 3 seconds Peak Power ⁽¹⁾		90		
		R _L = 4 Ω, 1% THD+N, Single Channel, 40 seconds Peak Power ⁽¹⁾		90		
THD+N	Total harmonic distortion + noise	1 W		0.005%		
V _n	Output integrated noise	A-weighted, AES17 filter, Input Capacitor Grounded		60		μV
V _{OS}	Output offset voltage	Inputs AC coupled to GND		20	60	mV
SNR	Signal-to-noise ratio ⁽²⁾			111		dB
DNR	Dynamic range			111		dB
P _{idle}	Power dissipation due to Idle losses (I _{PVDD_X})	P _O = 0, 4 channels switching ⁽³⁾		0.38		W

(1) Peak Power rating using TPA3244 EVM

(2) SNR is calculated relative to 1% THD+N output level.

(3) Actual system idle losses also are affected by core losses of output inductors.

7.7 Audio Characteristics (SE)

PCB and system configuration are in accordance with recommended guidelines. Audio frequency = 1 kHz, PVDD_X = 30 V, GVDD_X = 12 V, R_L = 4 Ω, f_S = 450 kHz, R_{OC} = 22 kΩ, T_A = 25°C, Output Filter: L_{DEM} = 15 μH, C_{DEM} = 1 μF, MODE = 11, AES17 + AUX-0025 measurement filters, unless otherwise noted.

PARAMETER		TEST CONDITIONS	MIN	TYP	MAX	UNIT
P _O	Power output per channel	R _L = 4 Ω, 10% THD+N		30		W
		R _L = 3 Ω, 10% THD+N		39		
		R _L = 4 Ω, 1% THD+N		25		
		R _L = 3 Ω, 1% THD+N		32		
THD+N	Total harmonic distortion + noise	1 W		0.01%		
V _n	Output integrated noise	A-weighted, AES17 filter, Input Capacitor Grounded		100		μV
SNR	Signal to noise ratio ⁽¹⁾	A-weighted		100		dB
DNR	Dynamic range	A-weighted		101		dB
P _{idle}	Power dissipation due to idle losses (IPVDD_X)	P _O = 0, 4 channels switching ⁽²⁾		0.38		W

(1) SNR is calculated relative to 1% THD+N output level.

(2) Actual system idle losses are affected by core losses of output inductors.

7.8 Audio Characteristics (PBTL)

PCB and system configuration are in accordance with recommended guidelines. Audio frequency = 1 kHz, PVDD_X = 30 V, GVDD_X = 12 V, R_L = 4 Ω, f_S = 450 kHz, R_{OC} = 22 kΩ, T_A = 25°C, Output Filter: L_{DEM} = 10 μH, C_{DEM} = 1 μF, MODE = 10, outputs paralleled before LC filter, AES17 + AUX-0025 measurement filters, unless otherwise noted.

PARAMETER		TEST CONDITIONS	MIN	TYP	MAX	UNIT
P _O	Power output per channel	R _L = 4 Ω, 10% THD+N		125		W
		R _L = 3 Ω, 10% THD+N		160		
		R _L = 4 Ω, 1% THD+N		100		
		R _L = 3 Ω, 1% THD+N		130		
THD+N	Total harmonic distortion + noise	1 W		0.005%		
V _n	Output integrated noise	A-weighted, AES17 filter, Input Capacitor Grounded		55		μV
SNR	Signal to noise ratio ⁽¹⁾	A-weighted		112		dB
DNR	Dynamic range	A-weighted		112		dB
P _{idle}	Power dissipation due to idle losses (IPVDD_X)	P _O = 0, 4 channels switching ⁽²⁾		0.38		W

(1) SNR is calculated relative to 1% THD+N output level.

(2) Actual system idle losses are affected by core losses of output inductors.

7.9 Typical Characteristics

7.9.1 BTL Configuration

All Measurements taken at audio frequency = 1 kHz, PVDD_X = 30 V, GVDD_X = 12 V, $R_L = 8 \Omega$, $f_S = 450 \text{ kHz}$, $R_{OC} = 22 \text{ k}\Omega$, $T_A = 25^\circ\text{C}$, Output Filter: $L_{DEM} = 10 \mu\text{H}$, $C_{DEM} = 1 \mu\text{F}$, mode = 00, AES17 + AUX-0025 measurement filters, unless otherwise noted.

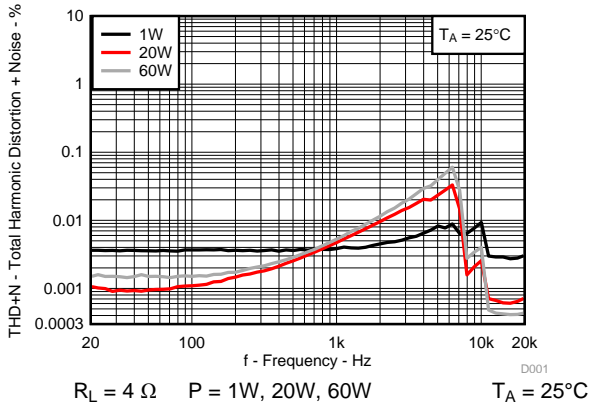

Figure 1. Total Harmonic Distortion+Noise vs Frequency

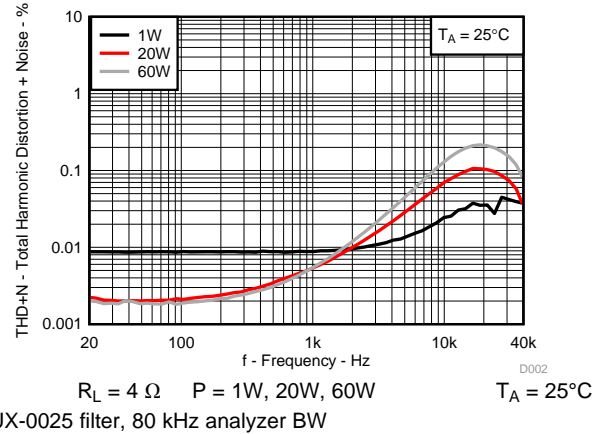

Figure 2. Total Harmonic Distortion+Noise vs Frequency

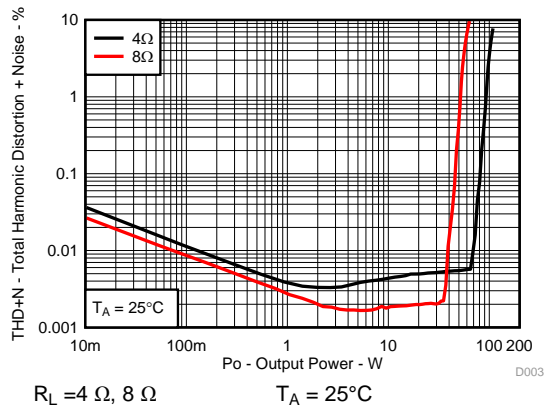

Figure 3. Total Harmonic Distortion + Noise vs Output Power

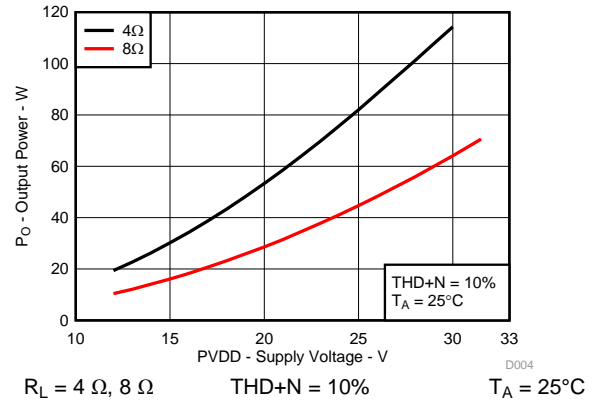

Figure 4. Output Power vs Supply Voltage

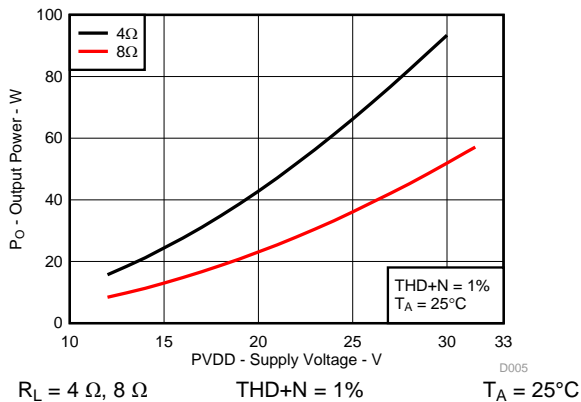

Figure 5. Output Power vs Supply Voltage

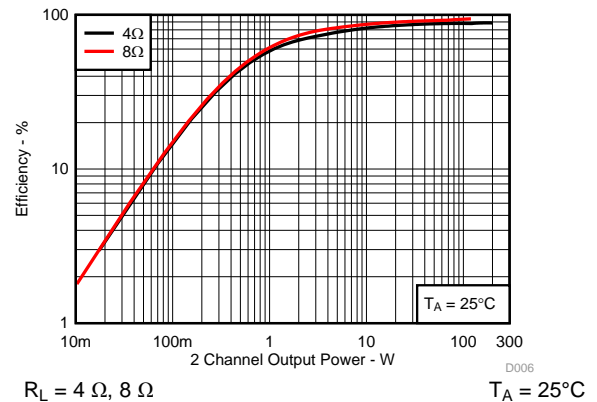
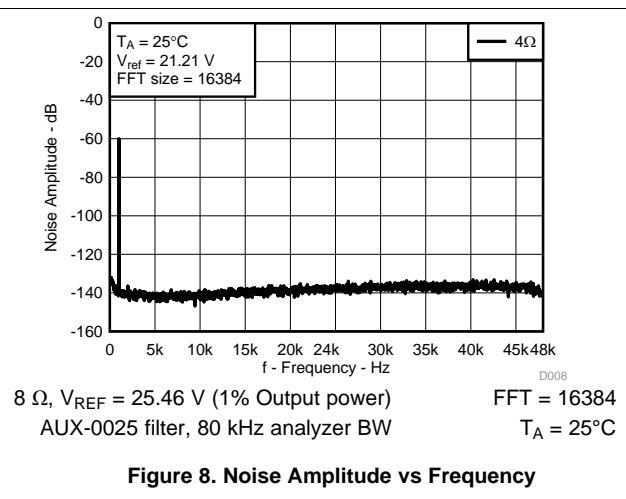
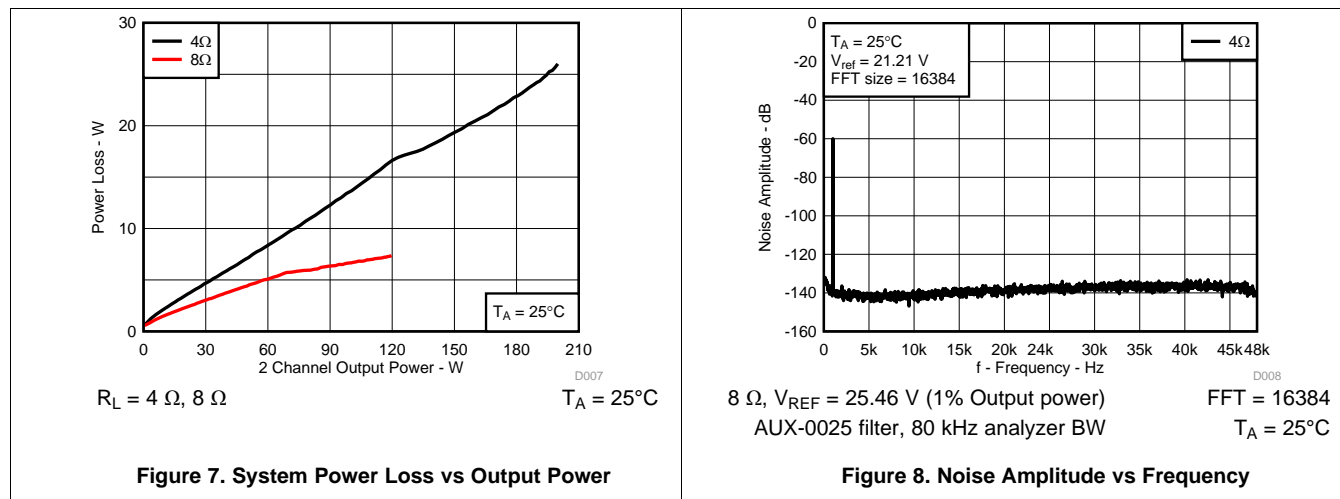

Figure 6. System Efficiency vs Output Power

BTL Configuration (continued)



7.9.2 SE Configuration

All Measurements taken at audio frequency = 1 kHz, PVDD_X = 30 V, GVDD_X = 12 V, R_L = 4 Ω, f_S = 450 kHz, R_{OC} = 22 kΩ, T_A = 25°C, Output Filter: L_{DEM} = 15 μH, C_{DEM} = 680 nF, MODE = 11, AES17 + AUX-0025 measurement filters, unless otherwise noted.

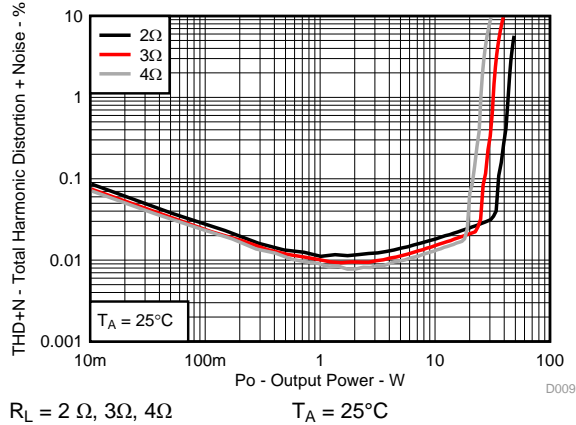

Figure 9. Total Harmonic Distortion+Noise vs Output Power

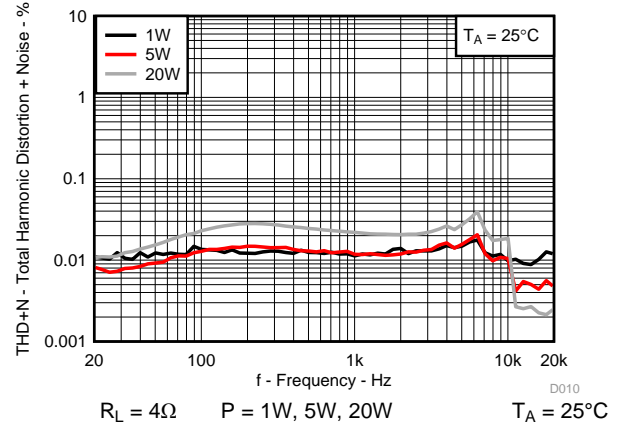

Figure 10. Total Harmonic Distortion+Noise vs Frequency

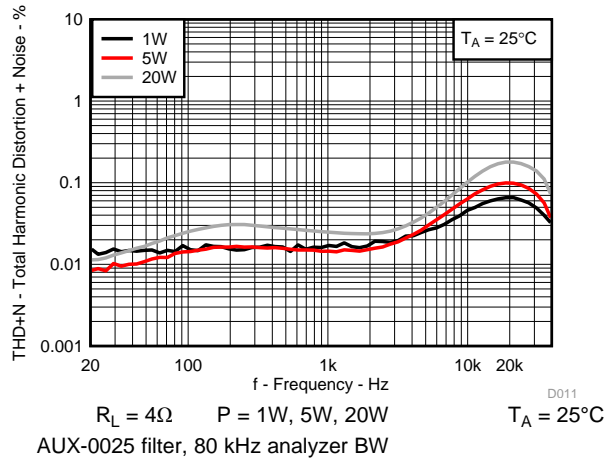

Figure 11. Total Harmonic Distortion+Noise vs Frequency

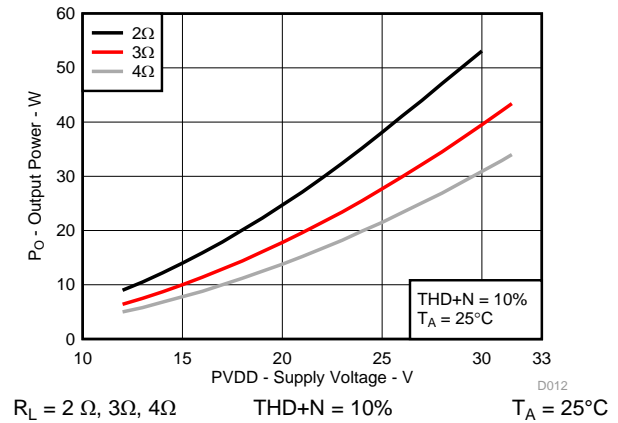

Figure 12. Output Power vs Supply Voltage

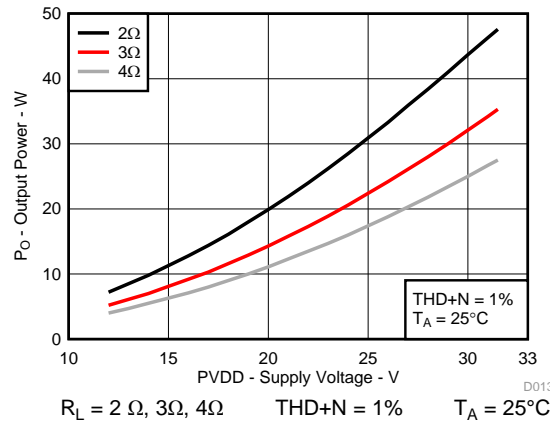
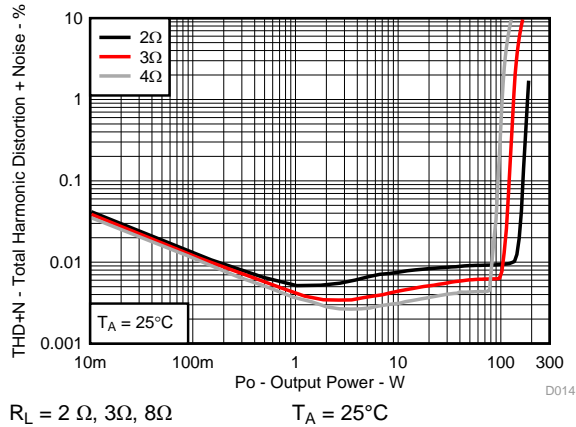

Figure 13. Output Power vs Supply Voltage

7.9.3 PBTL Configuration

All Measurements taken at audio frequency = 1kHz, PVDD_X = 30 V, GVDD_X = 12 V, $R_L = 4\Omega$, $f_S = 450$ kHz, $R_{OC} = 22$ k Ω , $T_A = 25^\circ\text{C}$, Output Filter: $L_{DEM} = 10$ μH , $C_{DEM} = 1$ μF , MODE = 10, outputs paralleled before LC filter, AES17 + AUX-0025 measurement filters, unless otherwise noted.



$R_L = 2\Omega, 3\Omega, 8\Omega$ $T_A = 25^\circ\text{C}$
Figure 14. Total Harmonic Distortion+Noise vs Output Power

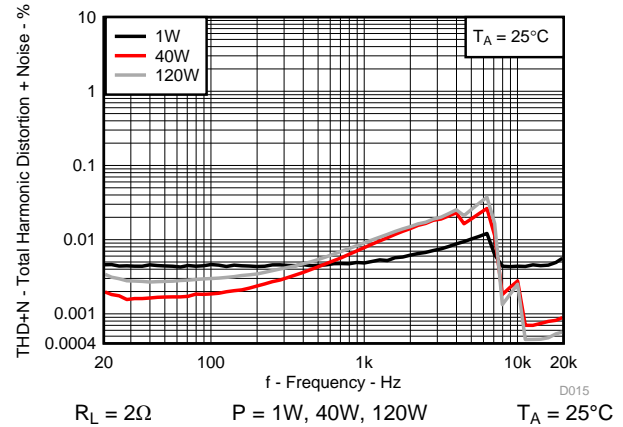

$R_L = 2\Omega$ $P = 1\text{W}, 40\text{W}, 120\text{W}$ $T_A = 25^\circ\text{C}$
Figure 15. Total Harmonic Distortion+Noise vs Frequency

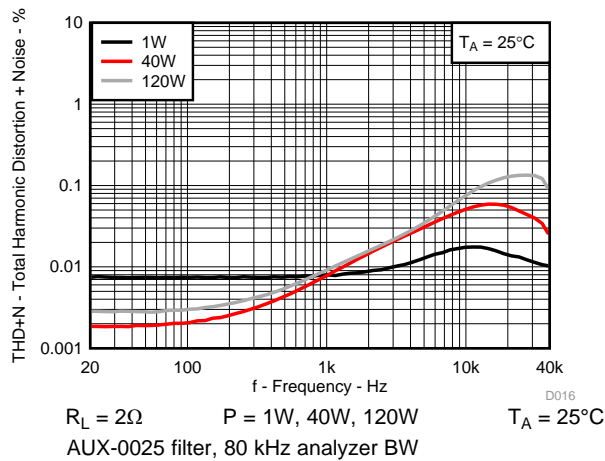

$R_L = 2\Omega$ $P = 1\text{W}, 40\text{W}, 120\text{W}$ $T_A = 25^\circ\text{C}$
 AUX-0025 filter, 80 kHz analyzer BW
Figure 16. Total Harmonic Distortion+Noise vs Frequency

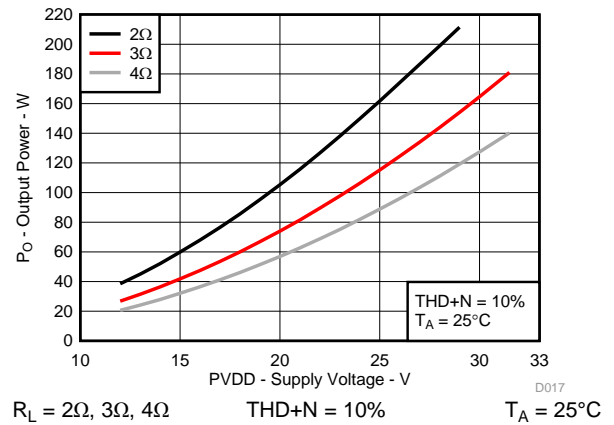

$R_L = 2\Omega, 3\Omega, 4\Omega$ $\text{THD+N} = 10\%$ $T_A = 25^\circ\text{C}$
Figure 17. Output Power vs Supply Voltage

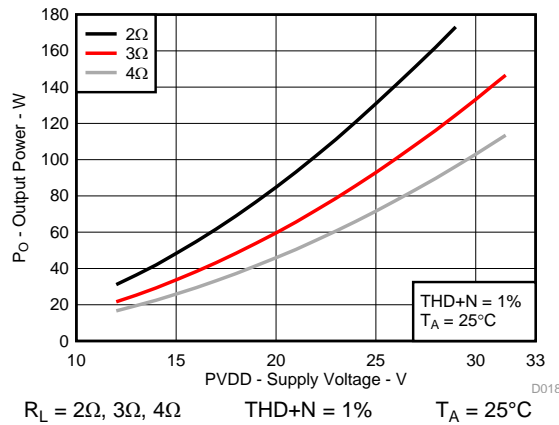

$R_L = 2\Omega, 3\Omega, 4\Omega$ $\text{THD+N} = 1\%$ $T_A = 25^\circ\text{C}$
Figure 18. Output Power vs Supply Voltage

8 Parameter Measurement Information

All parameters are measured according to the conditions described in the [Recommended Operating Conditions](#), [BTL Configuration](#), [SE Configuration](#) and [PBTL Configuration](#) sections.

Most audio analyzers will not give correct readings of Class-D amplifiers' performance due to their sensitivity to out of band noise present at the amplifier output. AES-17 + AUX-0025 pre-analyzer filters are recommended to use for Class-D amplifier measurements. In absence of such filters, a 30-kHz low-pass filter (10 Ω + 47 nF) can be used to reduce the out of band noise remaining on the amplifier outputs.

9 Detailed Description

9.1 Overview

To facilitate system design, the TPA3244 needs only a 12-V supply in addition to the (typical) 30-V power-stage supply. An internal voltage regulator provides suitable voltage levels for the digital and low-voltage analog circuitry, AVDD and DVDD. Additionally, all circuitry requiring a floating voltage supply, that is, the high-side gate drive, is accommodated by built-in bootstrap circuitry requiring only an external capacitor for each half-bridge.

The audio signal path including gate drive and output stage is designed as identical, independent half-bridges. For this reason, each half-bridge has separate bootstrap pins (BST_X). Power-stage supply pins (PVDD_X) and gate drive supply pins (GVDD_X) are separate for each full bridge. Although supplied from the same 12-V source, separating to GVDD_AB, GVDD_CD, and VDD on the printed-circuit board (PCB) by RC filters (see application diagram for details) is recommended. These RC filters provide the recommended high-frequency isolation. Special attention should be paid to placing all decoupling capacitors as close to their associated pins as possible. In general, the physical loop with the power supply pins, decoupling capacitors and GND return path to the device pins must be kept as short as possible and with as little area as possible to minimize induction (see reference board documentation for additional information).

For a properly functioning bootstrap circuit, a small ceramic capacitor must be connected from each bootstrap pin (BST_X) to the power-stage output pin (OUT_X). When the power-stage output is low, the bootstrap capacitor is charged through an internal diode connected between the gate-drive power-supply pin (GVDD_X) and the bootstrap pins. When the power-stage output is high, the bootstrap capacitor potential is shifted above the output potential and thus provides a suitable voltage supply for the high-side gate driver. It is recommended to use 33-nF ceramic capacitors, size 0603 or 0805, for the bootstrap supply. These 33nF capacitors ensure sufficient energy storage, even during minimal PWM duty cycles, to keep the high-side power stage FET (LDMOS) fully turned on during the remaining part of the PWM cycle.

Special attention should be paid to the power-stage power supply; this includes component selection, PCB placement, and routing. As indicated, each full-bridge has independent power-stage supply pins (PVDD_X). For optimal electrical performance, EMI compliance, and system reliability, it is important that each PVDD_X node is decoupled with 1- μ F ceramic capacitor placed as close as possible to the supply pins. It is recommended to follow the PCB layout of the TPA3244 reference design. For additional information on recommended power supply and required components, see the application diagrams in this data sheet.

The 12-V supply should be from a low-noise, low-output-impedance voltage regulator. Likewise, the 36-V power-stage supply is assumed to have low output impedance and low noise. The power-supply sequence is not critical as facilitated by the internal power-on-reset circuit, but it is recommended to release RESET after the power supply is settled for minimum power on audible artefacts. Moreover, the TPA3244 device is fully protected against erroneous power-stage turn on due to parasitic gate charging. Thus, voltage-supply ramp rates (dV/dt) are non-critical within the specified range.

9.2 Functional Block Diagrams

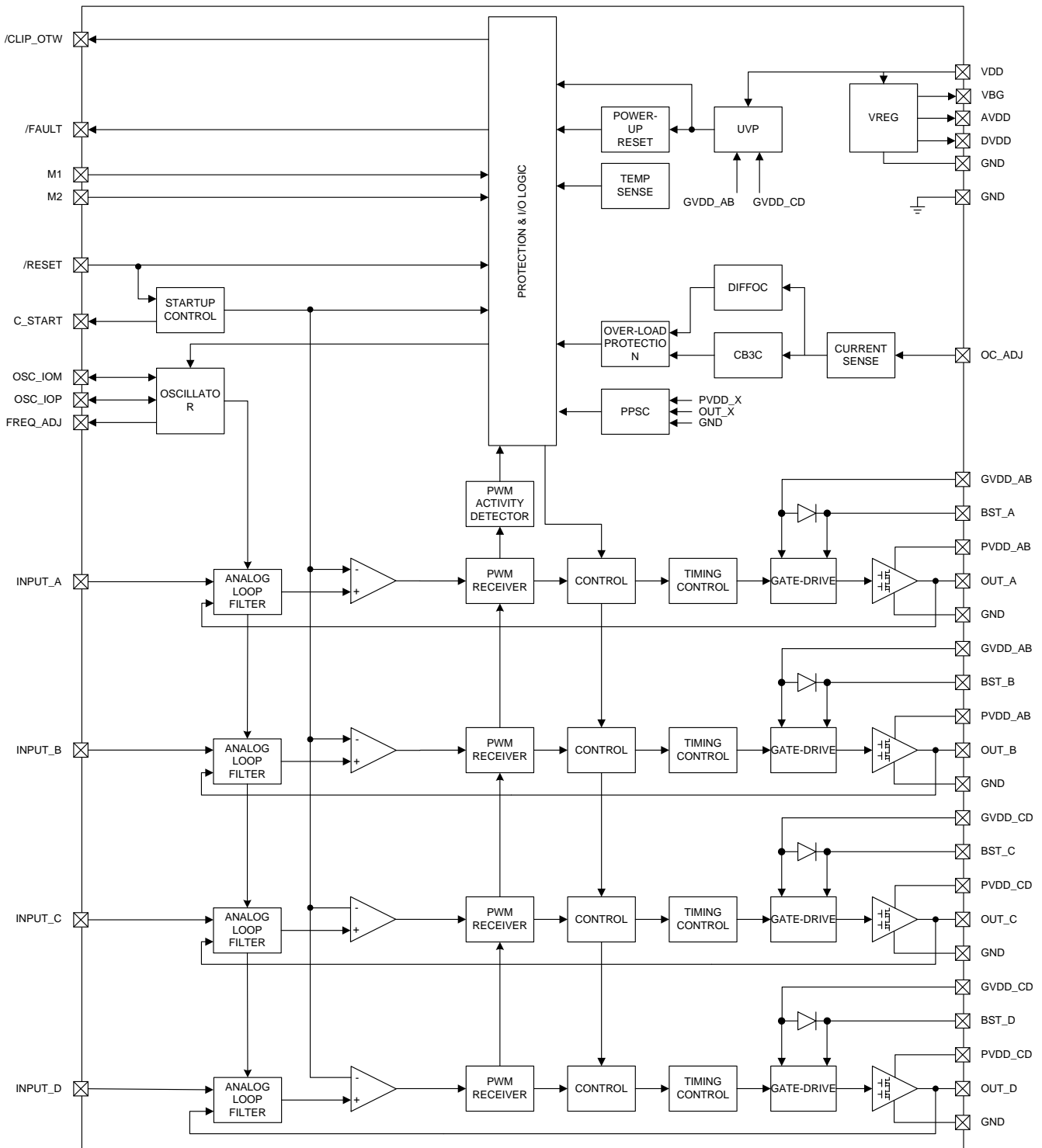

Copyright © 2016, Texas Instruments Incorporated

Functional Block Diagrams (continued)

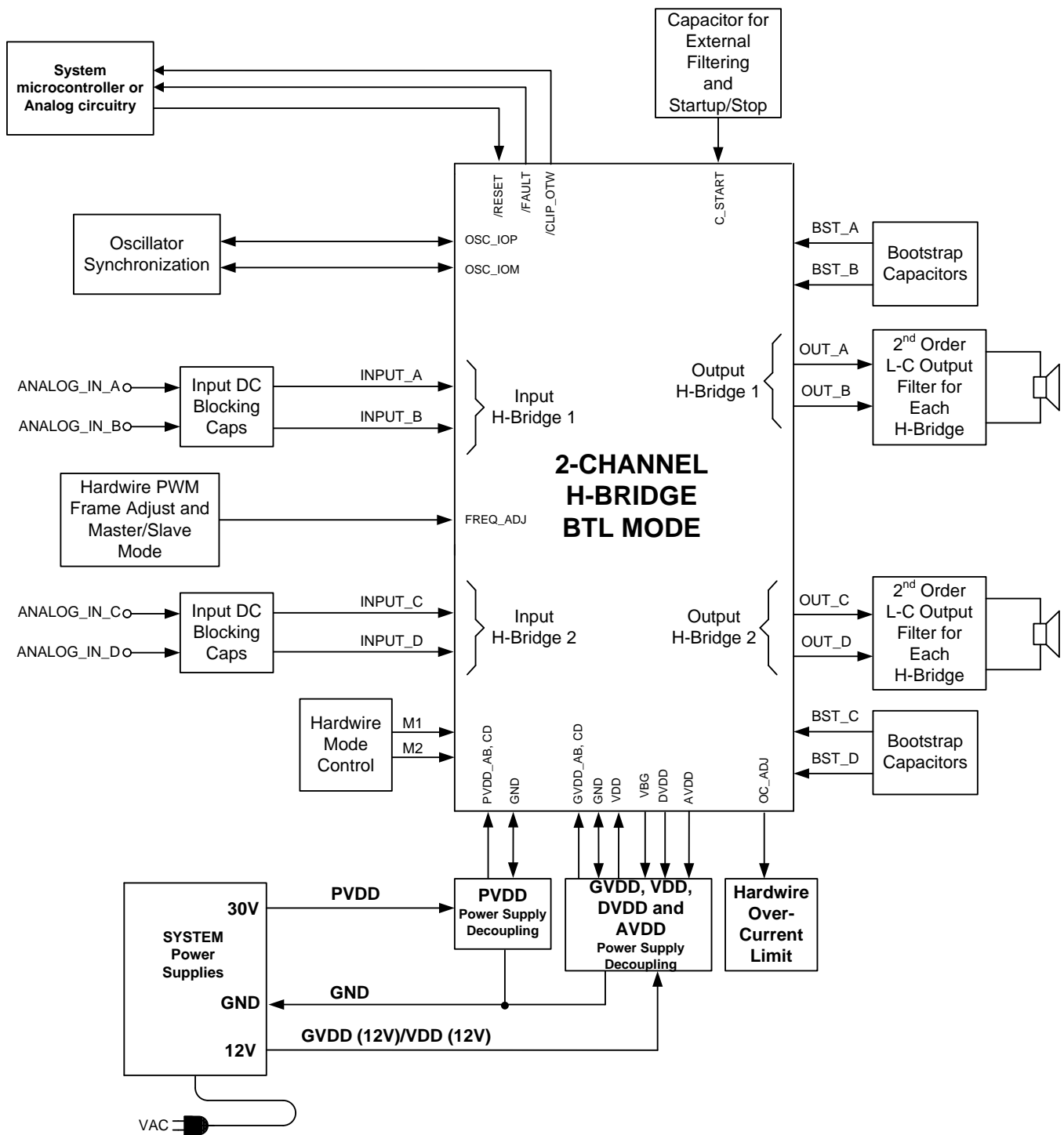

*NOTE1: Logic AND in or outside microcontroller

Copyright © 2016, Texas Instruments Incorporated

Figure 19. System Block Diagram

9.3 Feature Description

9.3.1 Error Reporting

The $\overline{\text{FAULT}}$, and $\overline{\text{CLIP_OTW}}$, pins are active-low, open-drain outputs. The function is for protection-mode signaling to a system-control device.

Any fault resulting in device shutdown is signaled by the $\overline{\text{FAULT}}$ pin going low. Also, $\overline{\text{CLIP_OTW}}$ goes low when the device junction temperature exceeds 125°C (see [Table 2](#)).

Table 2. Error Reporting

$\overline{\text{FAULT}}$	$\overline{\text{CLIP_OTW}}$	DESCRIPTION
0	0	Overtemperature (OTE) or overload (OLP) or undervoltage (UVP) Junction temperature higher than 125°C (overtemperature warning)
0	0	Overload (OLP) or undervoltage (UVP). Junction temperature higher than 125°C (overtemperature warning)
0	1	Overload (OLP) or undervoltage (UVP). Junction temperature lower than 125°C
1	0	Junction temperature higher than 125°C (overtemperature warning)
1	1	Junction temperature lower than 125°C and no OLP or UVP faults (normal operation)

Note that asserting $\overline{\text{RESET}}$ low forces the $\overline{\text{FAULT}}$ signal high, independent of faults being present. TI recommends monitoring the $\overline{\text{CLIP_OTW}}$ signal using the system microcontroller and responding to an overtemperature warning signal by, that is, turning down the volume to prevent further heating of the device resulting in device shutdown (OTE).

To reduce external component count, an internal pullup resistor to 3.3 V is provided on both $\overline{\text{FAULT}}$ and $\overline{\text{CLIP_OTW}}$ outputs.

9.4 Device Functional Modes

9.4.1 Device Protection System

The TPA3244 device contains advanced protection circuitry carefully designed to facilitate system integration and ease of use, as well as to safeguard the device from permanent failure due to a wide range of fault conditions such as short circuits, overload, overtemperature, and undervoltage. The TPA3244 device responds to a fault by immediately setting the power stage in a high-impedance (Hi-Z) state and asserting the $\overline{\text{FAULT}}$ pin low. In situations other than overload and overtemperature error (OTE), the device automatically recovers when the fault condition has been removed, that is, the supply voltage has increased.

The device will handle errors, as shown in [Table 3](#).

Table 3. Device Protection

BTL	MODE	PBTL	MODE	SE	MODE
LOCAL ERROR IN	URNS OFF	LOCAL ERROR IN	URNS OFF	LOCAL ERROR IN	URNS OFF
A	A+B	A	A+B+C+D	A	A+B
B		B		B	
C	C+D	C		C	C+D
D		D		D	

Bootstrap UVP does not shutdown according to the table, it shuts down the respective halfbridge (non-latching, does not assert $\overline{\text{FAULT}}$).

9.4.1.1 Overload and Short Circuit Current Protection

The TPA3244 device has fast reacting current sensors with a programmable trip threshold (OC threshold) on all high-side and low-side FETs. To prevent output current to increase beyond the programmed threshold, TPA3244 has the option of either limiting the output current for each switching cycle (Cycle By Cycle Current Control, CB3C) or to perform an immediate shutdown of the output in case of excess output current (Latching Shutdown). CB3C prevents premature shutdown due to high output current transients caused by high level music transients

and a drop of real speaker's load impedance, and allows the output current to be limited to a maximum programmed level. If the maximum output current persists, i.e. the power stage being overloaded with too low load impedance, the device will shut down the affected output channel and the affected output is put in a high-impedance (Hi- Z) state until a RESET cycle is initiated. CB3C works individually for each half bridge output. If an over current event is triggered, CB3C performs a state flip of the half bridge output that is cleared upon beginning of next PWM frame.

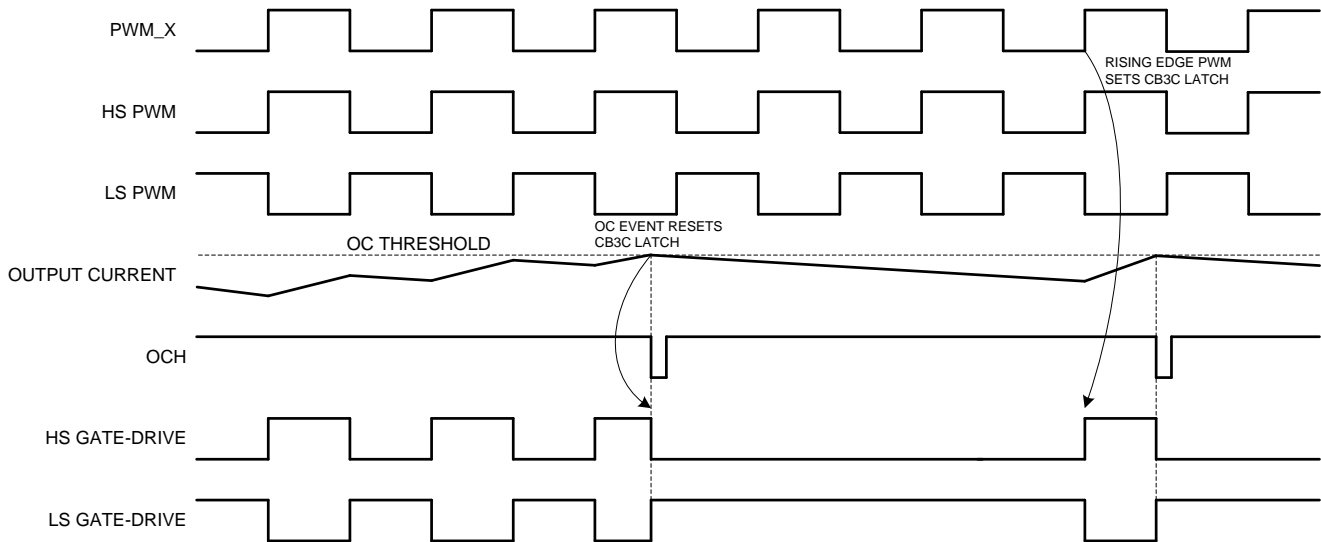

Figure 20. CB3C Timing Example

During CB3C an over load counter increments for each over current event and decrease for each non-over current PWM cycle. This allows full amplitude transients into a low speaker impedance without a shutdown protection action. In the event of a short circuit condition, the over current protection limits the output current by the CB3C operation and eventually shut down the affected output if the overload counter reaches its maximum value. If a latched OC operation is required such that the device shuts down the affected output immediately upon first detected over current event, this protection mode should be selected. The over current threshold and mode (CB3C or Latched OC) is programmed by the OC_ADJ resistor value. The OC_ADJ resistor needs to be within its intentional value range for either CB3C operation or Latched OC operation.

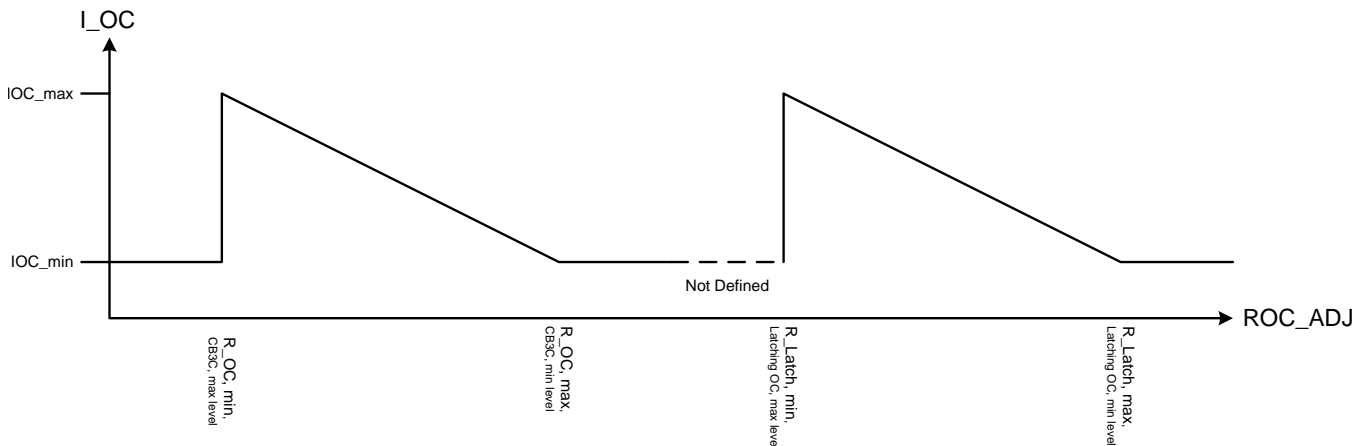

Figure 21. OC Threshold versus OC_ADJ Resistor Value Example

OC_ADJ values outside specified value range for either CB3C or latched OC operation will result in minimum OC threshold.

Table 4. Device Protection

OC_ADJ Resistor Value	Protection Mode	OC Threshold
22kΩ	CB3C	16.3A
24kΩ	CB3C	15.1A
27kΩ	CB3C	13.5A
30kΩ	CB3C	12.3A
47kΩ	Latched OC	16.3A
51kΩ	Latched OC	15.1A
56kΩ	Latched OC	13.5A
64kΩ	Latched OC	12.3A

9.4.1.2 Signal Clipping and Pulse Injector

A built in activity detector monitors the PWM activity of the OUT_X pins. TPA3244 is designed to drive unclipped output signals all the way to PVDD and GND rails. In case of audio signal clipping when applying excessive input signal voltage, or in case of CB3C current protection being active, the amplifier feedback loop of the audio channel will respond to this condition with a saturated state, and the output PWM signals will stop unless special circuitry is implemented to handle this situation. To prevent the output PWM signals from stopping in a clipping or CB3C situation, narrow pulses are injected to the gate drive to maintain output activity. The injected narrow pulses are injected at every 4th PWM frame, and thus the effective switching frequency during this state is reduced to 1/4 of the normal switching frequency.

Signal clipping is signalled on the CLIP_OTW pin and is self clearing when signal level reduces and the device reverts to normal operation. The CLIP_OTW pulses starts at the onset to output clipping, typically at a THD level around 0.01%, resulting in narrow CLIP_OTW pulses starting with a pulse width of ~500ns.

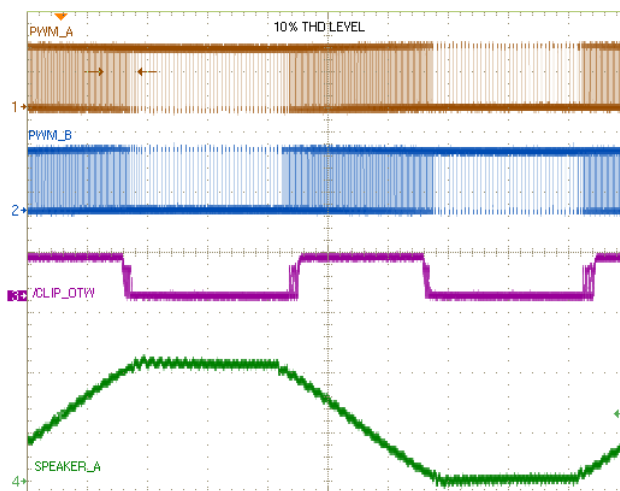

Figure 22. Signal Clipping PWM and Speaker Output Signals

9.4.1.3 DC Speaker Protection

The output DC protection scheme protects a speaker from excess DC current in case one terminal of the speaker is connected to the amplifier while the other is accidentally shorted to the chassis ground. Such a short circuit results in a DC voltage of PVDD/2 across the speaker, which potentially can result in destructive current levels. The output DC protection detects any unbalance of the output and input current of a BTL output, and in the event of the unbalance exceeding a programmed threshold, the overload counter increments until its maximum value and the affected output channel is shut down. DC Speaker Protection is disabled in PBTL and SE mode operation.

9.4.1.4 Pin-to-Pin Short Circuit Protection (PPSC)

The PPSC detection system protects the device from permanent damage in the case that a power output pin (OUT_X) is shorted to GND_X or PVDD_X. For comparison, the OC protection system detects an overcurrent after the demodulation filter where PPSC detects shorts directly at the pin before the filter. PPSC detection is performed at startup that is, when VDD is supplied, consequently a short to either GND_X or PVDD_X after system startup does not activate the PPSC detection system. When PPSC detection is activated by a short on the output, all half bridges are kept in a Hi-Z state until the short is removed; the device then continues the startup sequence and starts switching. The detection is controlled globally by a two step sequence. The first step ensures that there are no shorts from OUT_X to GND_X, the second step tests that there are no shorts from OUT_X to PVDD_X. The total duration of this process is roughly proportional to the capacitance of the output LC filter. The typical duration is < 15 ms/μF. While the PPSC detection is in progress, $\overline{\text{FAULT}}$ is kept low, and the device will not react to changes applied to the RESET pin. If no shorts are present the PPSC detection passes, and $\overline{\text{FAULT}}$ is released. A device reset will not start a new PPSC detection. PPSC detection is enabled in BTL and PBTl output configurations, the detection is not performed in SE mode. To make sure not to trip the PPSC detection system it is recommended not to insert a resistive load to GND_X or PVDD_X.

9.4.1.5 Overtemperature Protection OTW and OTE

The TPA3244 device has a two-level temperature-protection system that asserts an active-low warning signal (CLIP_OTW) when the device junction temperature exceeds 125°C (typical) and, if the device junction temperature exceeds 155°C (typical), the device is put into thermal shutdown, resulting in all half-bridge outputs being set in the high-impedance (Hi-Z) state and $\overline{\text{FAULT}}$ being asserted low. OTE is latched in this case. To clear the OTE latch, RESET must be asserted. Thereafter, the device resumes normal operation.

9.4.1.6 Undervoltage Protection (UVP) and Power-on Reset (POR)

The UVP and POR circuits of the TPA3244 device fully protect the device in any power-up/down and brownout situation. While powering up, the POR circuit resets the overload circuit (OLP) and ensures that all circuits are fully operational when the GVDD_X and VDD supply voltages reach values stated in the [Electrical Characteristics](#) table. Although GVDD_X and VDD are independently monitored, a supply voltage drop below the UVP threshold on any VDD or GVDD_X pin results in all half-bridge outputs immediately being set in the high-impedance (Hi-Z) state and $\overline{\text{FAULT}}$ being asserted low. The device automatically resumes operation when all supply voltages have increased above the UVP threshold.

9.4.1.7 Fault Handling

If a fault situation occurs while in operation, the device acts accordingly to the fault being a global or a channel fault. A global fault is a chip-wide fault situation and causes all PWM activity of the device to be shut down, and will assert $\overline{\text{FAULT}}$ low. A global fault is a latching fault and clearing $\overline{\text{FAULT}}$ and restart operation requires resetting the device by toggling RESET. Toggling RESET should never be allowed with excessive system temperature, so it is advised to monitor RESET by a system microcontroller and only allow releasing RESET (RESET high) if the OTW signal is cleared (high). A channel fault results in shutdown of the PWM activity of the affected channel(s). Note that asserting RESET low forces the $\overline{\text{FAULT}}$ signal high, independent of faults being present. TI recommends monitoring the OTW signal using the system micro controller and responding to an over temperature warning signal by, that is, turning down the volume to prevent further heating of the device resulting in device shutdown (OTE).

Table 5. Error Reporting

Fault/Event	Fault/Event Description	Global or Channel	Reporting Method	Latched/Self Clearing	Action needed to Clear	Output FETs
PVDD_X UVP	Voltage Fault	Global	$\overline{\text{FAULT}}$ pin	Self Clearing	Increase affected supply voltage	Hi-Z
VDD UVP						
AVDD UVP						
POR (DVDD UVP)	Power On Reset	Global	$\overline{\text{FAULT}}$ pin	Self Clearing	Allow DVDD to rise	Hi-Z
BST_X UVP	Voltage Fault	Channel (Half Bridge)	None	Self Clearing	Allow BST cap to recharge (lowside ON, VDD 12V)	HighSide off

Table 5. Error Reporting (continued)

Fault/Event	Fault/Event Description	Global or Channel	Reporting Method	Latched/Self Clearing	Action needed to Clear	Output FETs
OTW	Thermal Warning	Global	$\overline{\text{OTW}}$ pin	Self Clearing	Cool below OTW threshold	Normal operation
OTE	Thermal Shutdown	Global	$\overline{\text{FAULT}}$ pin	Latched	Toggle $\overline{\text{RESET}}$	HI-Z
OLP (CB3C>1.7ms)	OC Shutdown	Channel	$\overline{\text{FAULT}}$ pin	Latched	Toggle $\overline{\text{RESET}}$	HI-Z
Latched OC (47k Ω <ROC_ADJ<68k Ω)	OC Shutdown	Channel	$\overline{\text{FAULT}}$ pin	Latched	Toggle $\overline{\text{RESET}}$	HI-Z
CB3C (22k Ω <ROC_ADJ<30k Ω)	OC Limiting	Channel	None	Self Clearing	Reduce signal level or remove short	Flip state, cycle by cycle at fs/3
Stuck at Fault ⁽¹⁾	No OSC_IO activity in Slave Mode	Global	None	Self Clearing	Resume OSC_IO activity	HI-Z

(1) Stuck at Fault occurs when input OSC_IO input signal frequency drops below minimum frequency given in the [Electrical Characteristics](#) table of this data sheet.

9.4.1.8 Device Reset

Asserting $\overline{\text{RESET}}$ low initiates the device ramp down. The output FETs go into a Hi-Z state after the ramp down is complete. Output pull downs are active both in SE mode and BTL mode with $\overline{\text{RESET}}$ low.

In BTL modes, to accommodate bootstrap charging prior to switching start, asserting the reset input low enables weak pulldown of the half-bridge outputs.

Asserting reset input low removes any fault information to be signaled on the $\overline{\text{FAULT}}$ output, that is, $\overline{\text{FAULT}}$ is forced high. A rising-edge transition on reset input allows the device to resume operation after an overload fault. To ensure thermal reliability, the rising edge of reset must occur no sooner than 4 ms after the falling edge of $\overline{\text{FAULT}}$.

10 Application and Implementation

NOTE

Information in the following applications sections is not part of the TI component specification, and TI does not warrant its accuracy or completeness. TI's customers are responsible for determining suitability of components for their purposes. Customers should validate and test their design implementation to confirm system functionality.

10.1 Application Information

TPA3244 can be configured either in stereo BTL mode, 4 channel SE mode, mono PBTL mode, or in 2.1 mixed 1x BTL + 2x SE mode depending on output power conditions and system design.

10.2 Typical Applications

10.2.1 Stereo BTL Application

This section provides an example for configuring the TPA3244 in bridge-tied load (BTL) mode.

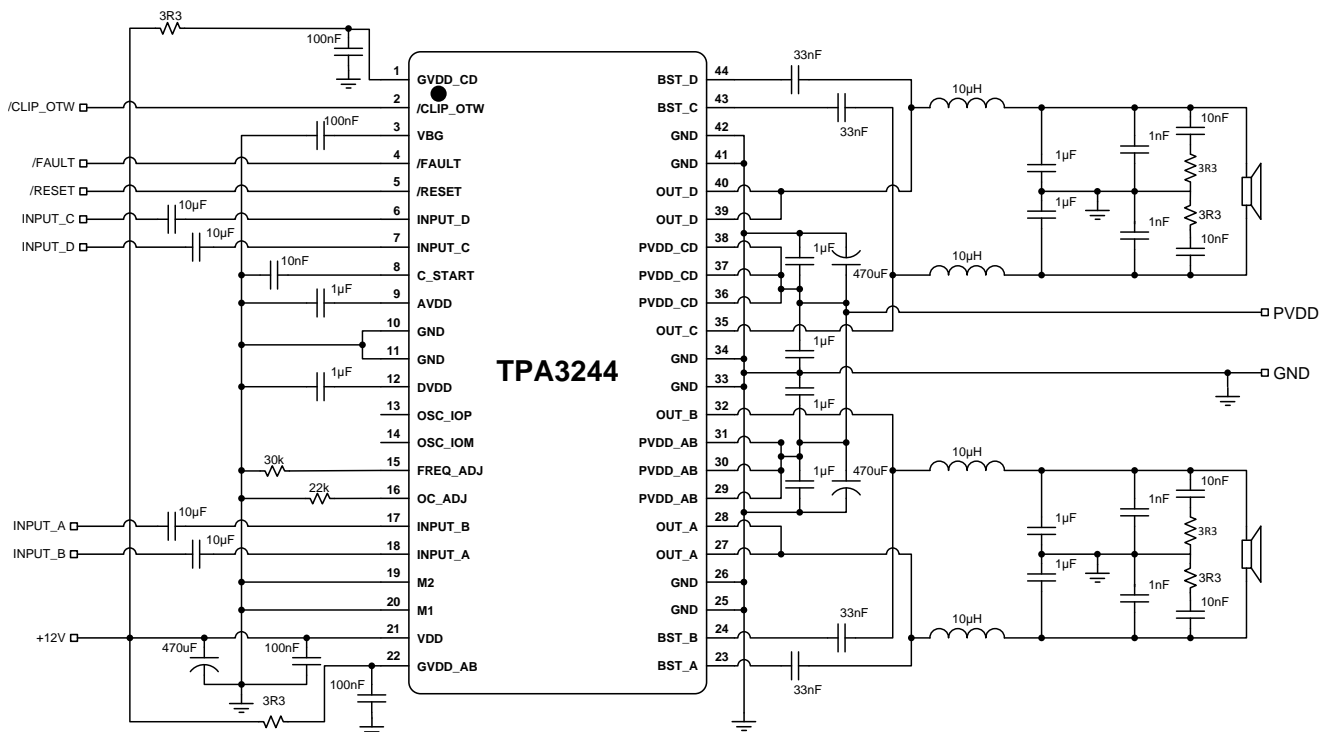

Copyright © 2016, Texas Instruments Incorporated

Figure 23. Typical Differential (2N) BTL Application

Typical Applications (continued)

10.2.1.1 Design Requirements

For this design example, use the parameters in [Table 6](#).

Table 6. Design Requirements, BTL Application

DESIGN PARAMETER	EXAMPLE
Low Power (Pull-up) Supply	3.3 V
Mid Power Supply 12 V	12 V
High Power Supply	12 - 30 V
Mode Selection	M2 = L
	M1 = L
Analog Inputs	INPUT_A = ± 3.9 V (peak, max)
	INPUT_B = ± 3.9 V (peak, max)
	INPUT_C = ± 3.9 V (peak, max)
	INPUT_D = ± 3.9 V (peak, max)
Output Filters	Inductor-Capacitor Low Pass Filter (10 μ H + 1 μ F)
Speaker Impedance	3 - 8 Ω

10.2.1.2 Detailed Design Procedures

A rising-edge transition on reset input allows the device to execute the startup sequence and starts switching.

The CLIP signal is indicating that the output is approaching clipping. The signal can be used to either an audio volume decrease or intelligent power supply nominally operating at a low rail adjusting to a higher supply rail.

The device is inverting the audio signal from input to output.

The DVDD and AVDD pins are not recommended to be used as a voltage sources for external circuitry.

10.2.1.2.1 Decoupling Capacitor Recommendations

In order to design an amplifier that has robust performance, passes regulatory requirements, and exhibits good audio performance, good quality decoupling capacitors should be used. In practice, X7R should be used in this application.

10.2.1.2.2 PVDD Capacitor Recommendation

The PVDD decoupling capacitors must be placed as close to the device pins as possible to insure short trace length and low inductance path. Likewise the ground path for these capacitors must provide a good reference and should be substantial. This will keep voltage ringing on PVDD to a minimum.

The voltage of the decoupling capacitors should be selected in accordance with good design practices. Temperature, ripple current, and voltage overshoot must be considered. This fact is particularly true in the selection of the 1 μ F that is placed on the power supply to each full-bridge. It must withstand the voltage overshoot of the PWM switching, the heat generated by the amplifier during high power output, and the ripple current created by high power output. A minimum voltage rating of 50 V is required for use with a 30V power supply.

The large capacitors used in conjunction with each full-bridge, are referred to as the PVDD Capacitors. These capacitors should be selected for proper voltage margin and adequate capacitance to support the power requirements. In practice, with a well designed system power supply, 1000 μ F, 50 V supports most applications. The PVDD capacitors should be low ESR type because they are used in a circuit associated with high-speed switching.

10.2.1.2.3 PCB Material Recommendation

FR-4 Glass Epoxy material with 2 oz. (70 μ m) copper is recommended for use with the TPA3244 device. The use of this material can provide for higher power output, improved thermal performance, and better EMI margin (due to lower PCB trace inductance).

10.2.1.2.4 Oscillator

The built in oscillator frequency can be trimmed by an external resistor from the `FREQ_ADJ` pin to GND. Changes in the oscillator frequency should be made with resistor values specified in [Recommended Operating Conditions](#) while `RESET` is low.

To reduce interference problems while using a radio receiver tuned within the AM band, the switching frequency can be changed from nominal to lower or higher values. These values should be chosen such that the nominal and the alternate switching frequencies together result in the fewest cases of interference throughout the AM band. The oscillator frequency can be selected by the value of the `FREQ_ADJ` resistor connected to GND in master mode.

For slave mode operation, turn off the oscillator by pulling the `FREQ_ADJ` pin to DVDD. This configures the `OSC_I/O` pins as inputs to be slaved from an external differential clock. In a master/slave system inter-channel delay is automatically set up between the switching of the audio channels, which can be illustrated by no idle channels switching at the same time. This will not influence the audio output, but only the switch timing to minimize noise coupling between audio channels through the power supply. Inter-channel delay is needed to optimize audio performance and to get better operating conditions for the power supply. The inter-channel delay will be set up for a slave device depending on the polarity of the `OSC_I/O` connection as follows:

- Slave 1 mode has normal polarity (master + to slave + and master - to slave -)
- Slave 2 mode has reverse polarity (master + to slave - and master - to slave +)

The interchannel delay for interleaved channel idle switching is given in the table below for the master/slave and output configuration modes in degrees relative to the PWM frame.

Table 7. Master/Slave Inter Channel Delay Settings

Master	M1 = 0, M2 = 0, 2 x BTL mode	M1 = 1, M2 = 0, 1 x BTL + 2 x SE mode	M1 = 0, M2 = 1, 1 x PBTL mode	M1 = 1, M2 = 1, 4 x SE mode
OUT_A	0°	0°	0°	0°
OUT_B	180°	180°	180°	60°
OUT_C	60°	60°	0°	0°
OUT_D	240°	120°	180°	60°
Slave 1				
OUT_A	60°	60°	60°	60°
OUT_B	240°	240°	240°	120°
OUT_C	120°	120°	60°	60°
OUT_D	300°	180°	240°	120°
Slave 2				
OUT_A	30°	30°	30°	30°
OUT_B	210°	210°	210°	90°
OUT_C	90°	90°	30°	30°
OUT_D	270°	150°	210°	90°

10.2.1.3 Application Curves

Relevant performance plots for the TPA3244 device shown in are shown in [BTL Configuration](#).

Table 8. Relevant Performance Plots, BTL Configuration

PLOT TITLE	FIGURE NUMBER
Total Harmonic Distortion+Noise vs Frequency	Figure 1
Total Harmonic Distortion+Noise vs Frequency, 80kHz analyzer BW	Figure 2
Total Harmonic Distortion + Noise vs Output Power	Figure 3
Output Power vs Supply Voltage, 10% THD+N	Figure 4
Output Power vs Supply Voltage, 10% THD+N	Figure 6
System Efficiency vs Output Power	Figure 6
System Power Loss vs Output Power	Figure 7
Output Power vs Case Temperature	
Noise Amplitude vs Frequency	Figure 8

10.2.2 Typical Application, Single Ended (1N) SE

This section provides an example for configuring the TPA3244 in single-ended output (SE) mode.

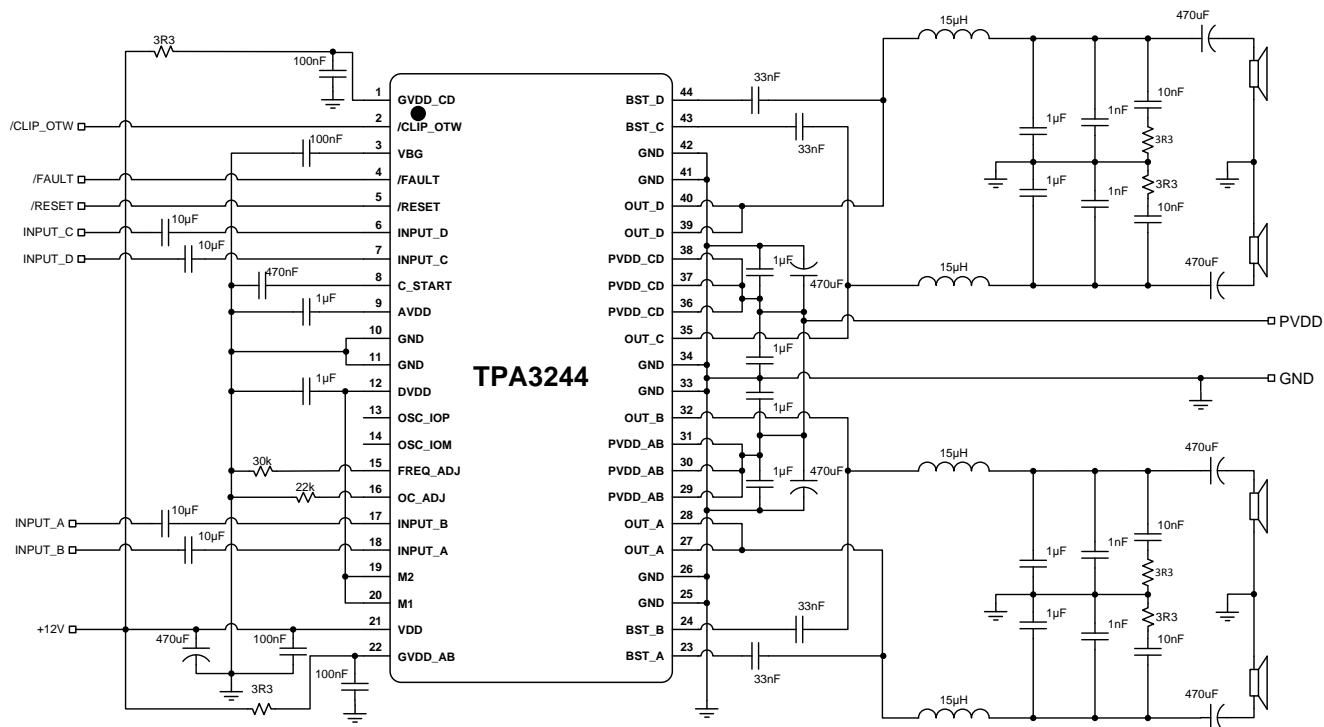

Copyright © 2016, Texas Instruments Incorporated

Figure 24. Typical Single Ended (1N) SE Application

10.2.2.1 Design Requirements

For this design example, use the parameters in Table 9.

Table 9. Design Requirements, SE Application

DESIGN PARAMETER	EXAMPLE
Low Power (Pull-up) Supply	3.3 V
Mid Power Supply 12 V	12 V
High Power Supply	12 - 30 V
Mode Selection	M2 = H
	M1 = H
Analog Inputs	INPUT_A = ±3.9 V (peak, max)
	INPUT_B = ±3.9 V (peak, max)
	INPUT_C = ±3.9 V (peak, max)
	INPUT_D = ±3.9 V (peak, max)
Output Filters	Inductor-Capacitor Low Pass Filter (15 µH + 680 nF)
Speaker Impedance	2 - 8 Ω

10.2.2.2 Application Curves

Relevant performance plots for TPA3244 shown in [SE Configuration](#).

Table 10. Relevant Performance Plots, SE Configuration

PLOT TITLE	FIGURE NUMBER
Total Harmonic Distortion + Noise vs Output Power	Figure 3
Total Harmonic Distortion+Noise vs Frequency	Figure 1
Total Harmonic Distortion+Noise vs Frequency, 80kHz analyzer BW	Figure 2
Output Power vs Supply Voltage, 10% THD+N	Figure 4
Output Power vs Supply Voltage, 10% THD+N	Figure 6
Output Power vs Case Temperature	

10.2.3 Typical Application, Differential (2N), PBTL (Outputs Paralleled before LC filter)

TPA3244 can be configured in mono PBTL mode by paralleling the outputs before the LC filter or after the LC filter (see [Typical Application, Differential \(2N\), PBTL \(Outputs Paralleled after LC filter\)](#)). Paralleled outputs before the LC filter is recommended for better performance and limiting the number of output LC filter inductors, only two inductors required. This sections shows an example of paralleled outputs before the LC filter.

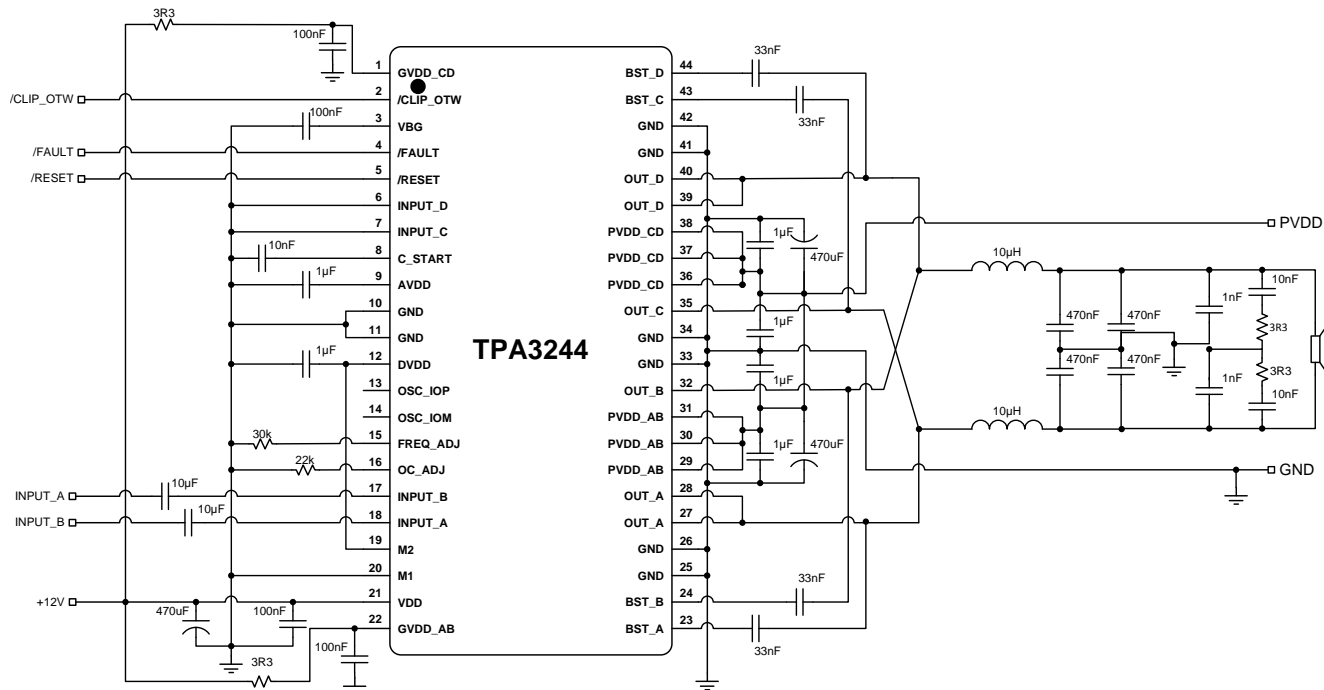

Copyright © 2016, Texas Instruments Incorporated

Figure 25. Typical Differential (2N) PBTL (Outputs Paralleled before LC filter) Application

10.2.3.1 Design Requirements

For this design example, use the parameters in [Table 11](#).

Table 11. Design Requirements, PBTL (Outputs Paralleled before LC filter) Application

DESIGN PARAMETER	EXAMPLE
Low Power (Pull-up) Supply	3.3 V
Mid Power Supply 1 2V	12 V
High Power Supply	12 - 30 V
Mode Selection	M2 = H
	M1 = L
Analog Inputs	INPUT_A = ±3.9 V (peak, max)
	INPUT_B = ±3.9 V (peak, max)
	INPUT_C = ±3.9 V (peak, max)
	INPUT_D = ±3.9 V (peak, max)
Output Filters	Inductor-Capacitor Low Pass Filter (10 μH + 1 μF)
Speaker Impedance	2 - 4 Ω

10.2.3.2 Application Curves

Relevant performance plots for TPA3244 shown in [PBTL Configuration](#).

Table 12. Relevant Performance Plots, PBTL (Outputs Paralleled before LC filter) Configuration

PLOT TITLE	FIGURE NUMBER
Total Harmonic Distortion + Noise vs Output Power	Figure 3
Total Harmonic Distortion+Noise vs Frequency	Figure 1
Total Harmonic Distortion+Noise vs Frequency, 80kHz analyzer BW	Figure 2
Output Power vs Supply Voltage, 10% THD+N	Figure 4
Output Power vs Supply Voltage, 10% THD+N	Figure 6
Output Power vs Case Temperature	

10.3 Typical Application, Differential (2N), PBTL (Outputs Paralleled after LC filter)

TPA3244 can be configured in mono PBTL mode by paralleling the outputs before the LC filter (see [Typical Application, Differential \(2N\), PBTL \(Outputs Paralleled before LC filter\)](#)) or after the LC filter. Paralleled outputs after the LC filter may be preferred if: a single board design must support both PBTL and BTL, or in the case multiple, smaller paralleled inductors are preferred due to size or cost. Paralleling after the LC filter requires four inductors, one for each OUT_x. This section shows an example of paralleled outputs after the LC filter.

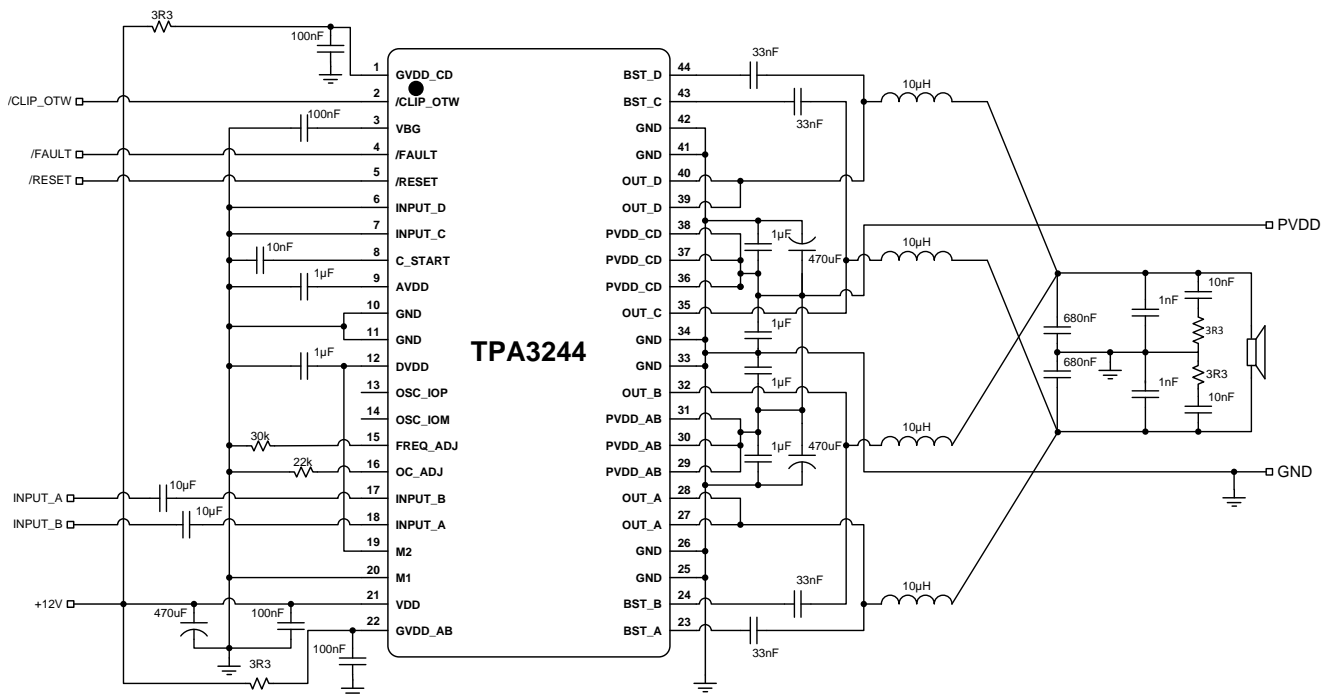

Copyright © 2016, Texas Instruments Incorporated

Figure 26. Typical Differential (2N) PBTL (Outputs Paralleled after LC filter) Application

10.3.1 Design Requirements

For this design example, use the parameters in [Table 13](#).

Table 13. Design Requirements, PBTL (Outputs Paralleled after LC filter) Application

DESIGN PARAMETER	EXAMPLE
Low Power (Pull-up) Supply	3.3 V
Mid Power Supply 12 V	12 V
High Power Supply	12 - 30 V
Mode Selection	M2 = H
	M1 = L
Analog Inputs	INPUT_A = ±3.9V (peak, max)
	INPUT_B = ±3.9V (peak, max)
	INPUT_C = Grounded
	INPUT_D = Grounded
Output Filters	Inductor-Capacitor Low Pass Filter (10 μH + 1 μF)
Speaker Impedance	2 - 4 Ω

10.3.2 Application Curves

Relevant performance plots for TPA3244 shown in [PBTL Configuration](#).

Table 14. Relevant Performance Plots, PBTL (Outputs Paralleled before LC filter) Configuration

PLOT TITLE	FIGURE NUMBER
Total Harmonic Distortion + Noise vs Output Power	Figure 3
Total Harmonic Distortion+Noise vs Frequency	Figure 1
Total Harmonic Distortion+Noise vs Frequency, 80kHz analyzer BW	Figure 2
Output Power vs Supply Voltage, 10% THD+N	Figure 4
Output Power vs Supply Voltage, 10% THD+N	Figure 6
Output Power vs Case Temperature	

11 Power Supply Recommendations

11.1 Power Supplies

The TPA3244 device requires two external power supplies for proper operation. A high-voltage supply called PVDD is required to power the output stage of the speaker amplifier and its associated circuitry. Additionally, one mid-voltage power supply for GVDD_X and VDD is required to power the gate-drive and other internal digital and analog portions of the device. The allowable voltage range for both the PVDD and the GVDD_X/VDD supplies are listed in the [Recommended Operating Conditions](#) table. Ensure both the PVDD and the GVDD_X/VDD supplies can deliver more current than listed in the [Electrical Characteristics](#) table.

11.1.1 VDD Supply

The VDD supply required from the system is used to power several portions of the device. It provides power to internal regulators DVDD and AVDD that are used to power digital and analog sections of the device, respectively. Proper connection, routing, and decoupling techniques are highlighted in the [TPA3244 Evaluation Module User's Guide \(SLVUAT5\)](#) (as well as the [Application Information](#) section and [Layout Examples](#) section) and must be followed as closely as possible for proper operation and performance. Deviation from the guidance offered in the [TPA3244 Evaluation Module User's Guide \(SLVUAT5\)](#), which followed the same techniques as those shown in the [Application Information](#) section, may result in reduced performance, errant functionality, or even damage to the TPA3244 device. Some portions of the device also require a separate power supply which is a lower voltage than the VDD supply. To simplify the power supply requirements for the system, the TPA3244 device includes integrated low-dropout (LDO) linear regulators to create these supplies. These linear regulators are internally connected to the VDD supply and their outputs are presented on AVDD and DVDD pins, providing a connection point for an external bypass capacitors. It is important to note that the linear regulators integrated in the device have only been designed to support the current requirements of the internal circuitry, and should not be used to power any additional external circuitry. Additional loading on these pins could cause the voltage to sag and increase noise injection, which negatively affects the performance and operation of the device.

11.1.2 GVDD_X Supply

The GVDD_X supply required from the system is used to power the gate-drives for the output H-bridges. Proper connection, routing, and decoupling techniques are highlighted in the [TPA3244 Evaluation Module User's Guide \(SLVUAT5\)](#) (as well as the [Application Information](#) section and [Layout Examples](#) section) and must be followed as closely as possible for proper operation and performance. Deviation from the guidance offered in the TPA3244 device EVM User's Guide, which followed the same techniques as those shown in the [Application Information](#) section, may result in reduced performance, errant functionality, or even damage to the TPA3244 device.

11.1.3 PVDD Supply

The output stage of the amplifier drives the load using the PVDD supply. This is the power supply which provides the drive current to the load during playback. Proper connection, routing, and decoupling techniques are highlighted in the [TPA3244 Evaluation Module User's Guide \(SLVUAT5\)](#) (as well as the [Application Information](#) section and [Layout Examples](#) section) and must be followed as closely as possible for proper operation and performance. Due the high-voltage switching of the output stage, it is particularly important to properly decouple the output power stages in the manner described in the [TPA3244 Evaluation Module User's Guide \(SLVUAT5\)](#). The lack of proper decoupling, like that shown in the EVM User's Guide, can results in voltage spikes which can damage the device, or cause poor audio performance and device shutdown faults.

11.2 Powering Up

The TPA3244 device does not require a power-up sequence, but it is recommended to hold $\overline{\text{RESET}}$ low for at least 250 ms after PVDD supply voltage is turned ON. The outputs of the H-bridges remain in a high-impedance state until the gate-drive supply voltage (GVDD_X) and VDD voltages are above the undervoltage protection (UVP) voltage threshold (see the [Electrical Characteristics](#) table of this data sheet). This allows an internal circuit to charge the external bootstrap capacitors by enabling a weak pulldown of the half-bridge output as well as initiating a controlled ramp up sequence of the output voltage.

Powering Up (continued)

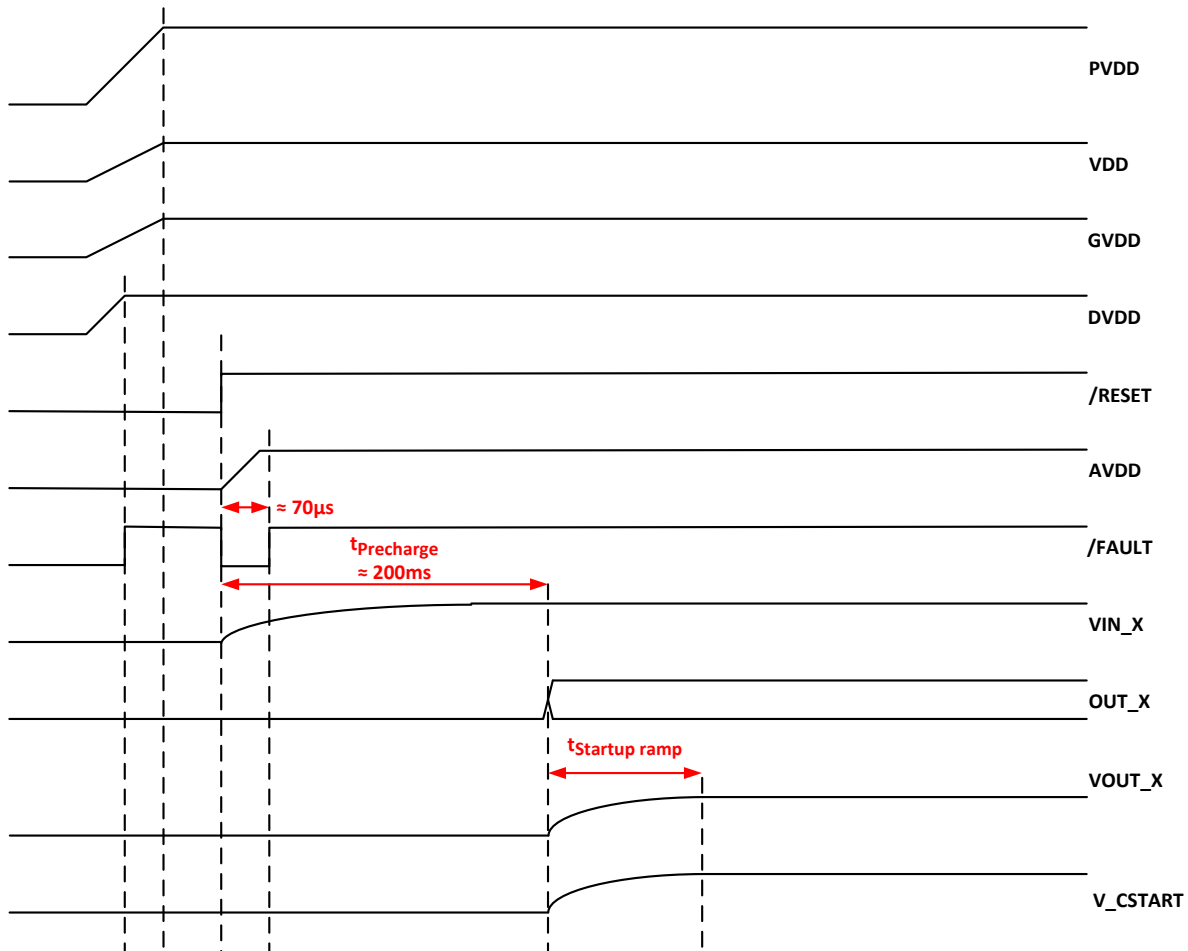

Figure 27. Startup Timing

When $\overline{\text{RESET}}$ is released to turn on the TPA3244 device, $\overline{\text{FAULT}}$ signal will turn low and AVDD voltage regulator will be enabled. $\overline{\text{FAULT}}$ will stay low until AVDD reaches the undervoltage protection (UVP) voltage threshold (see the Electrical Characteristics table of this data sheet). After a precharge time to stabilize the DC voltage across the input AC coupling capacitors, before the ramp up sequence starts.

11.3 Powering Down

The TPA3244 device does not require a power-down sequence. The device remains fully operational as long as the gate-drive supply (GVDD_X) voltage and VDD voltage are above the undervoltage protection (UVP) voltage threshold. Although not specifically required, it is a good practice to hold $\overline{\text{RESET}}$ low during power down, thus preventing audible artifacts including pops or clicks by initiating a controlled ramp down sequence of the output voltage.

11.4 Thermal Design

11.4.1 Thermal Performance

The TPA3244 device thermal performance is dependent on the thermal design of the PCB. As a result, the maximum continuous output power attainable will be influenced by the PCB design. The continuous power rating is lower than the peak output power capability of the device. The peak power rating of the TPA3244 device is based on the burst capability of the device. The peak to average power ratio of the TPA3244 device is well suited to handle even demanding audio playback without thermal shutdown. Thermal performance with typical audio content (burst) versus sine wave content (continuous) should be considered when defining the thermal test requirements for the end product.

11.4.2 Thermal Performance with Continuous Output Power

It is recommended to operate the TPA3244 device below the OTW threshold, which in most systems will require the average output power to be below the maximum peak output power. The maximum continuous power, the TPA3244 device will deliver depends directly on the thermal design of the PCB and for the entire system (closed box with no air flow, or a fanned system etc.). Thermal performance is also impacted by PVDD voltage and switching frequency. The best configuration for a given application will often depend on the continuous output power requirements.

Table 15. Device and PCB Temperatures with 8-Ω Load, T_A = 40°C

T _A = 40°C, TPA3244 EVM, No Airflow. Steady State Temperatures.						
PVDD	Switching Frequency	Continuous Power [W]		Device Top Temperature	Maximum PCB Temperature	Comment
30V	450kHz	63W	10% THD	128°C	93°C	OTW after 187 seconds.
30V	450kHz	31.5W	1/2 of 10% THD power	111°C	83°C	
30V	450kHz	15.75W	1/4 of 10% THD power	89°C	71°C	
30V	450kHz	7.9W	1/8 of 10% THD power	76°C	63°C	
30V	600kHz	62W	10% THD	141°C	100°C	OTW after 38 seconds. Not recommended.
30V	600kHz	31W	1/2 of 10% THD power	130°C	94°C	OTW after 205 seconds.
30V	600kHz	15.5W	1/4 of 10% THD power	99°C	77°C	
30V	600kHz	7.75W	1/8 of 10% THD power	84°C	68°C	

Table 16. Device and PCB Temperatures with 4-Ω Load, T_A = 40°C

T _A = 40°C, TPA3244 EVM, No Airflow. Steady State Temperatures.							
PVDD	Switching Frequency	Continuous Power [W]		Device Top Temperature	Maximum PCB Temperature	Comment	
30V	450kHz	114W	10% THD	OTE ⁽¹⁾		OTW and OTE after less than 1 second. Not recommended.	
30V	450kHz	57W	1/2 of 10% THD power	OTE ⁽¹⁾		OTW after 3 seconds and OTE after 9 seconds. Not recommended.	
30V	450kHz	28.5W	1/4 of 10% THD power	OTE ⁽¹⁾		OTW after 44 seconds and OTE after 327 seconds. Not recommended.	
30V	450kHz	14.25W	1/8 of 10% THD power	107°C	82°C		
30V	600kHz	Not recommended					
26V	450kHz	84W	10% THD	OTE ⁽¹⁾		OTW after 3 seconds and OTE after 6 seconds. Not recommended.	
26V	450kHz	42W	1/2 of 10% THD power	OTE ⁽¹⁾		OTW after 15 seconds and OTE after 56 seconds. Not recommended.	
26V	450kHz	21W	1/4 of 10% THD power	113°C	84°C		
26V	450kHz	10.5W	1/8 of 10% THD power	87°C	69°C		

(1) Steady state data is not available because device heats up to OTE in this condition.

Table 16. Device and PCB Temperatures with 4-Ω Load, T_A = 40°C (continued)

T _A = 40°C, TPA3244 EVM, No Airflow. Steady State Temperatures.						
26V	600kHz	83W	10% THD	OTE ⁽¹⁾		OTW after 3 seconds and OTE after 6 seconds. Not recommended.
26V	600kHz	41.5W	1/2 of 10% THD power	OTE ⁽¹⁾		OTW after 9 seconds and OTE after 30 seconds. Not recommended.
26V	600kHz	20.75W	1/4 of 10% THD power	129°C	93°C	OTW after 301 seconds.
30V	600kHz	10.50W	1/8 of 10% THD power	97°C	76°C	

11.4.3 Thermal Performance with Non-Continuous Output Power

As audio signals often have a peak to average ratio larger than one (average level below maximum peak output), the thermal performance for audio signals can be illustrated using burst signals with different burst ratios.

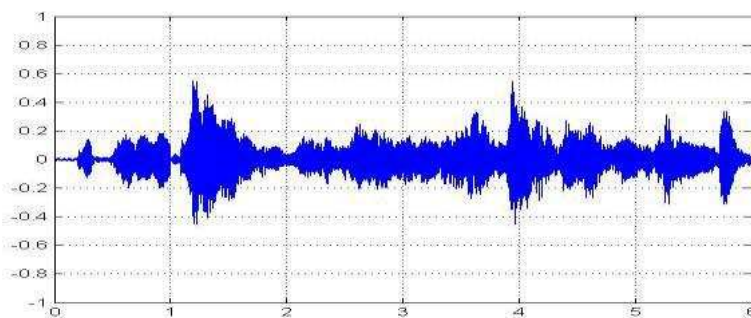

Figure 28. Example of audio signal

A burst signal is characterized by the high-level to low-level ratio as well as the duration of the high level and low level, e.g. a burst 1:4 stimuli is a single period of high level followed by 4 cycles of low level.

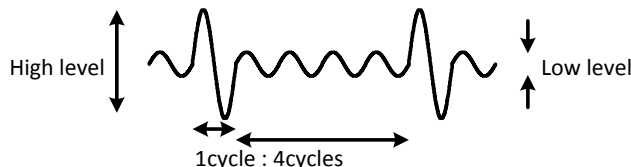

Figure 29. Example of 1:4 Burst Signal

The following analysis of thermal performance for the TPA3244 device is made with the TPA3244 EVM surrounded by still air (no airflow) with a controlled air temperature of 40°C. For 30 V operation the system is not thermally limited with 8Ω load, but depending on the burst stimuli for operation at 30V some thermal limitations may occur, depending on switching frequency and average to maximum power ratio. Low to maximum power ratio of the burst stimuli is given in the plots as for example P1:8 which equals low level burst cycles of 1/8 power of the high level cycles. The level of the high power cycles is set equal to 10% THD level.

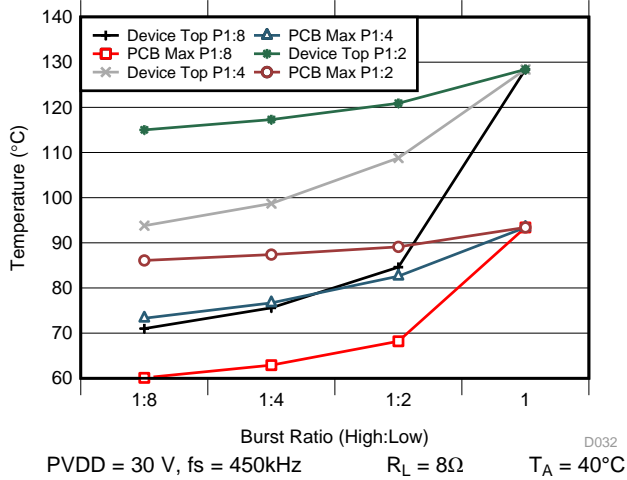

Figure 30. Device and PCB Temperatures vs. Burst Ratio

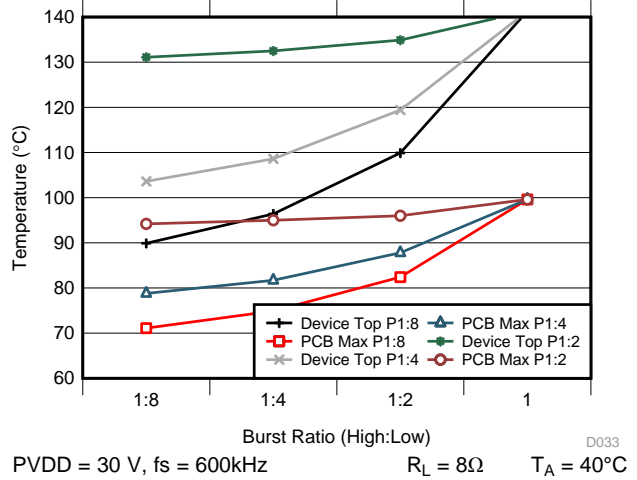

Figure 31. Device and PCB Temperatures vs. Burst Ratio

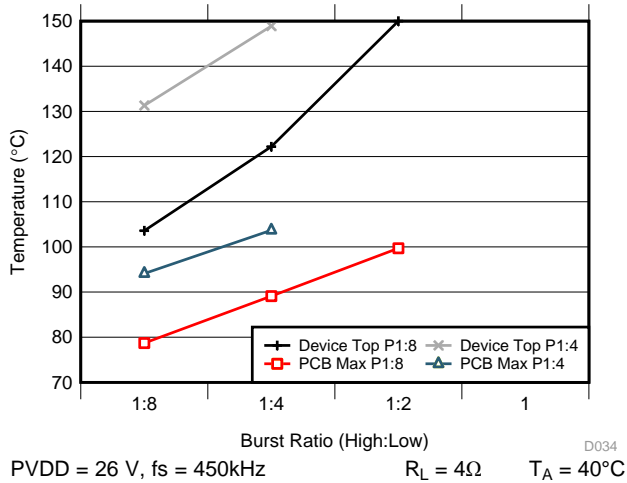

Figure 32. Device and PCB Temperatures vs. Burst Ratio

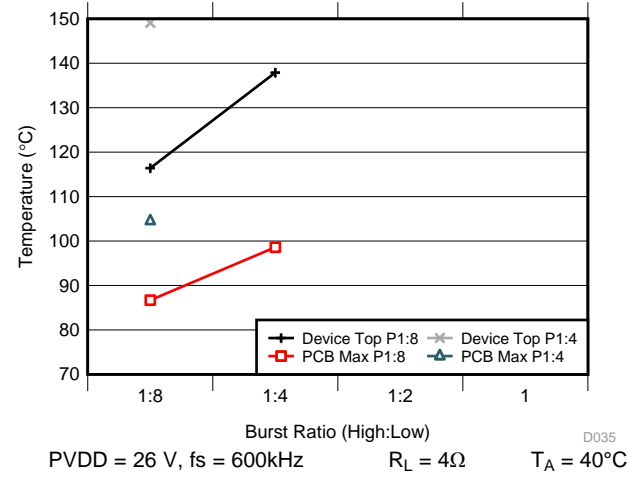

Figure 33. Device and PCB Temperatures vs. Burst Ratio

12 Layout

12.1 Layout Guidelines

- Use an unbroken ground plane to have good low impedance and inductance return path to the power supply for power and audio signals.
- Maintain a contiguous ground plane from the ground pins to the PCB area surrounding the device for as many of the ground pins as possible, since the ground pins are the best conductors of heat in the package.
- PCB layout, audio performance and EMI are linked closely together.
- Routing the audio input should be kept short and together with the accompanied audio source ground.
- The small bypass capacitors on the PVDD lines of the DUT be placed as close the PVDD pins as possible.
- A local ground area underneath the device is important to keep solid to minimize ground bounce.
- Orient the passive component so that the narrow end of the passive component is facing the TPA3244 device, unless the area between two pads of a passive component is large enough to allow copper to flow in between the two pads.
- Avoid placing other heat producing components or structures near the TPA3244 device.
- Avoid cutting off the flow of heat from the TPA3244 device to the surrounding ground areas with traces or via strings, especially on output side of device.

Netlist for this printed circuit board is generated from the schematic in [Figure 34](#).

12.2 Layout Examples

12.2.1 BTL Application Printed Circuit Board Layout Example

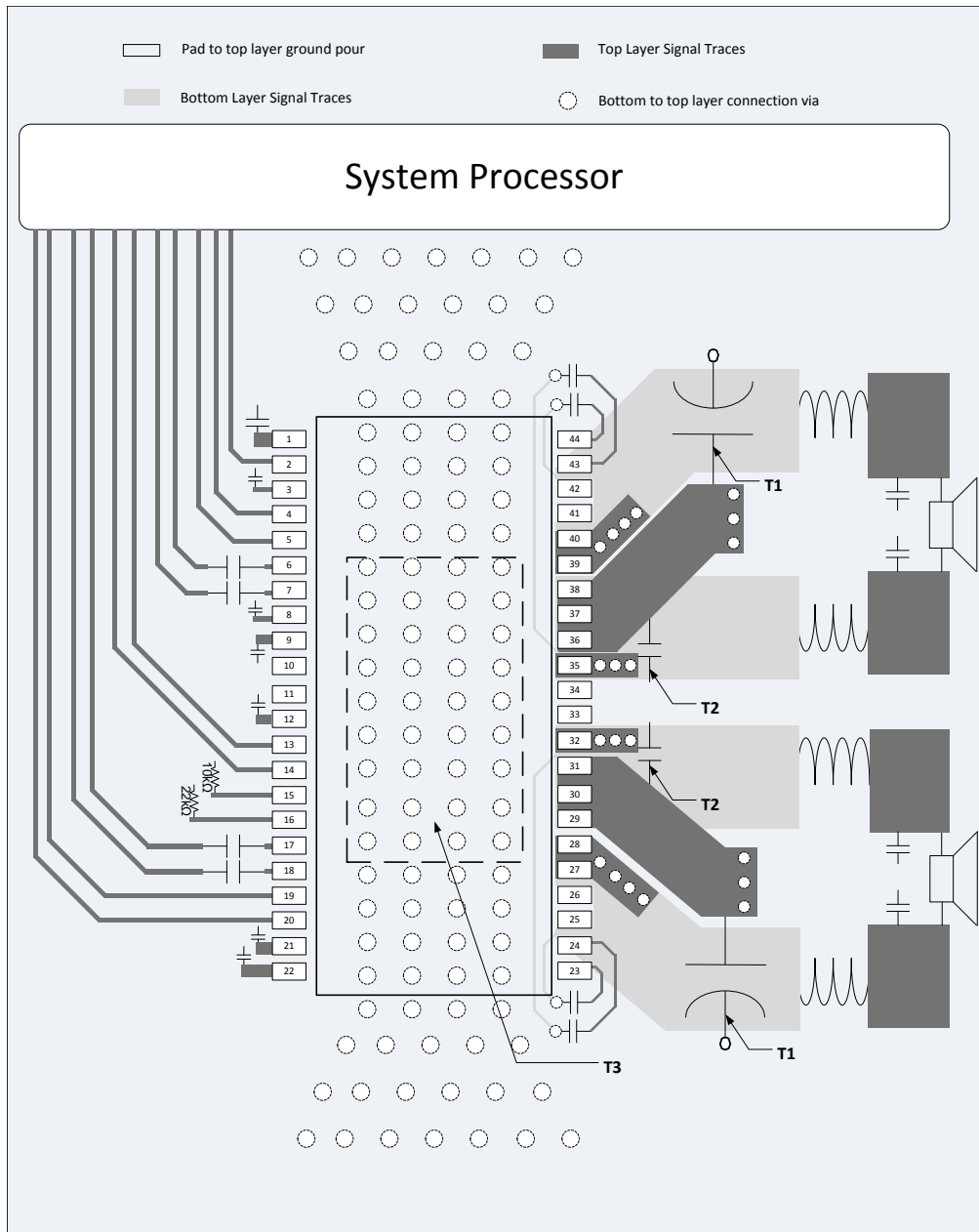

- A. Note: PCB layout example shows composite layout. Dark grey: Top layer copper traces, light gray: Bottom layer copper traces. All PCB area not used for traces should be GND copper pour (transparent on example image)
- B. **Note T1:** PVDD decoupling bulk capacitors should be as close as possible to the PVDD and GND_X pins. Wide traces should be routed on the top layer with direct connection to the pins and without going through vias. No vias or traces should be blocking the current path.
- C. **Note T2:** Close decoupling of PVDD with low impedance X7R ceramic capacitors placed close to the pins.
- D. **Note T3:** PowerPad™ needs to be soldered to PCB GND copper pour

Figure 34. BTL Application Printed Circuit Board - Composite

Layout Examples (continued)

12.2.2 SE Application Printed Circuit Board Layout Example

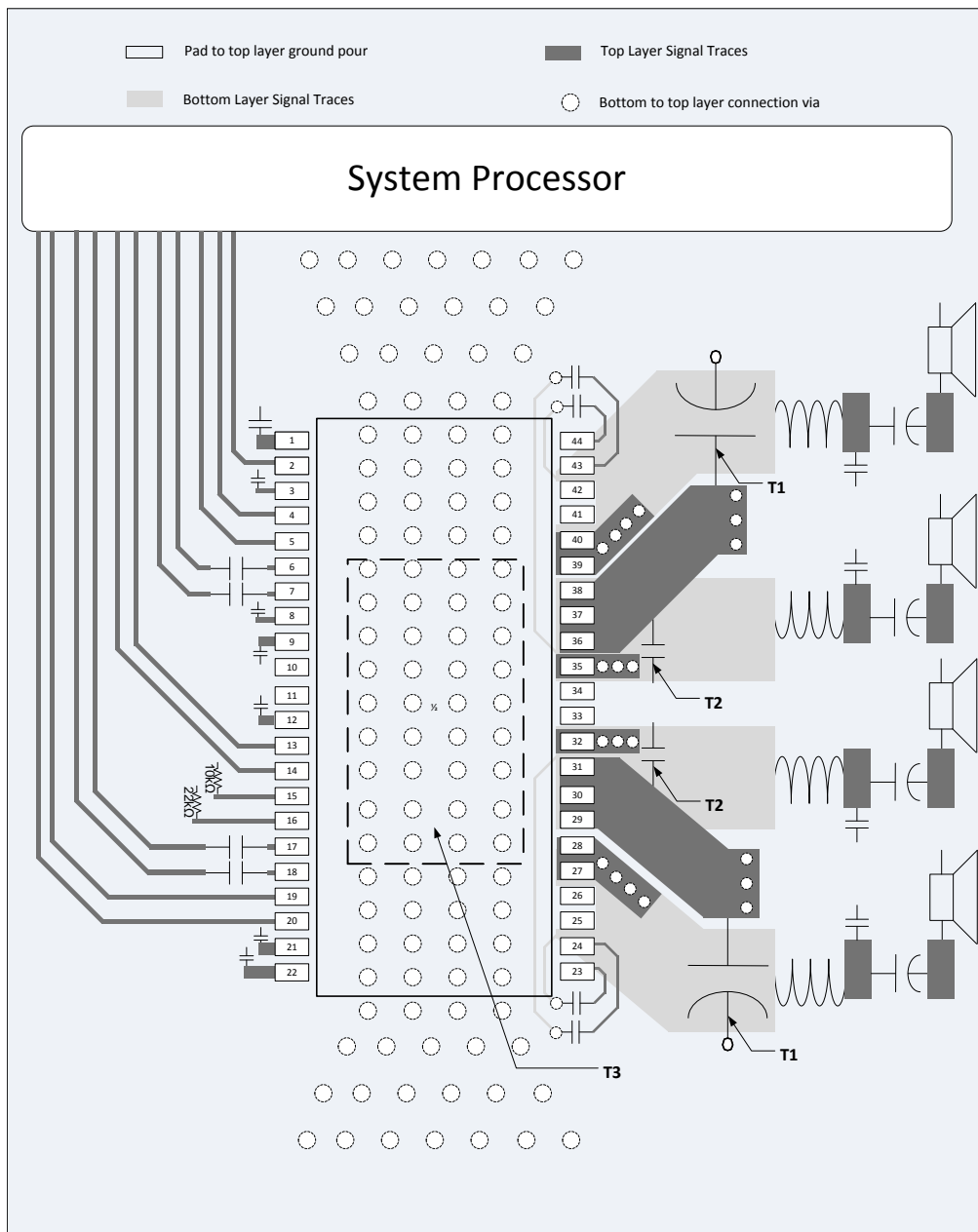

- A. Note: PCB layout example shows composite layout. Dark grey: Top layer copper traces, light gray: Bottom layer copper traces. All PCB area not used for traces should be GND copper pour (transparent on example image)
- B. **Note T1:** PVDD decoupling bulk capacitors should be as close as possible to the PVDD and GND_X pins. Wide traces should be routed on the top layer with direct connection to the pins and without going through vias. No vias or traces should be blocking the current path.
- C. **Note T2:** Close decoupling of PVDD with low impedance X7R ceramic capacitors is placed close to the pins.
- D. **Note T3:** PowerPad™ needs to be soldered to PCB GND copper pour

Figure 35. SE Application Printed Circuit Board - Composite

Layout Examples (continued)

12.2.3 PBTL (Outputs Paralleled before LC filter) Application Printed Circuit Board Layout Example

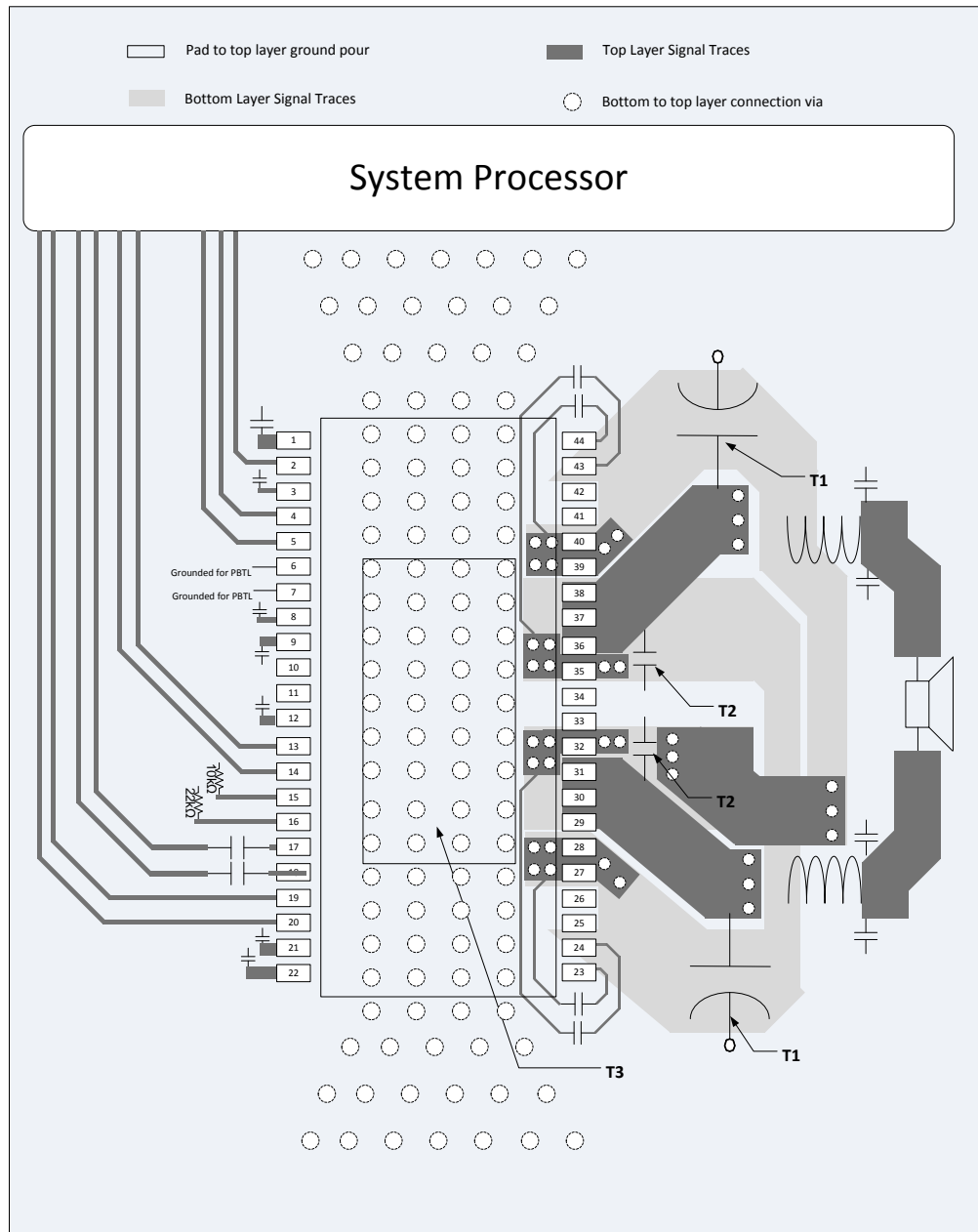

- A. Note: PCB layout example shows composite layout. Dark grey: Top layer copper traces, light gray: Bottom layer copper traces. All PCB area not used for traces should be GND copper pour (transparent on example image)
- B. **Note T1:** PVDD decoupling bulk capacitors should be as close as possible to the PVDD and GND_X pins, the heat sink sets the distance. Wide traces should be routed on the top layer with direct connection to the pins and without going through vias. No vias or traces should be blocking the current path.
- C. **Note T2:** Close decoupling of PVDD with low impedance X7R ceramic capacitors is placed under the heat sink and close to the pins.
- D. **Note T3:** Heat sink needs to have a good connection to PCB ground.

Figure 36. PBTL (Outputs Paralleled before LC filter) Application Printed Circuit Board - Composite

Layout Examples (continued)

12.2.4 PBTL (Outputs Paralleled after LC filter) Application Printed Circuit Board Layout Example

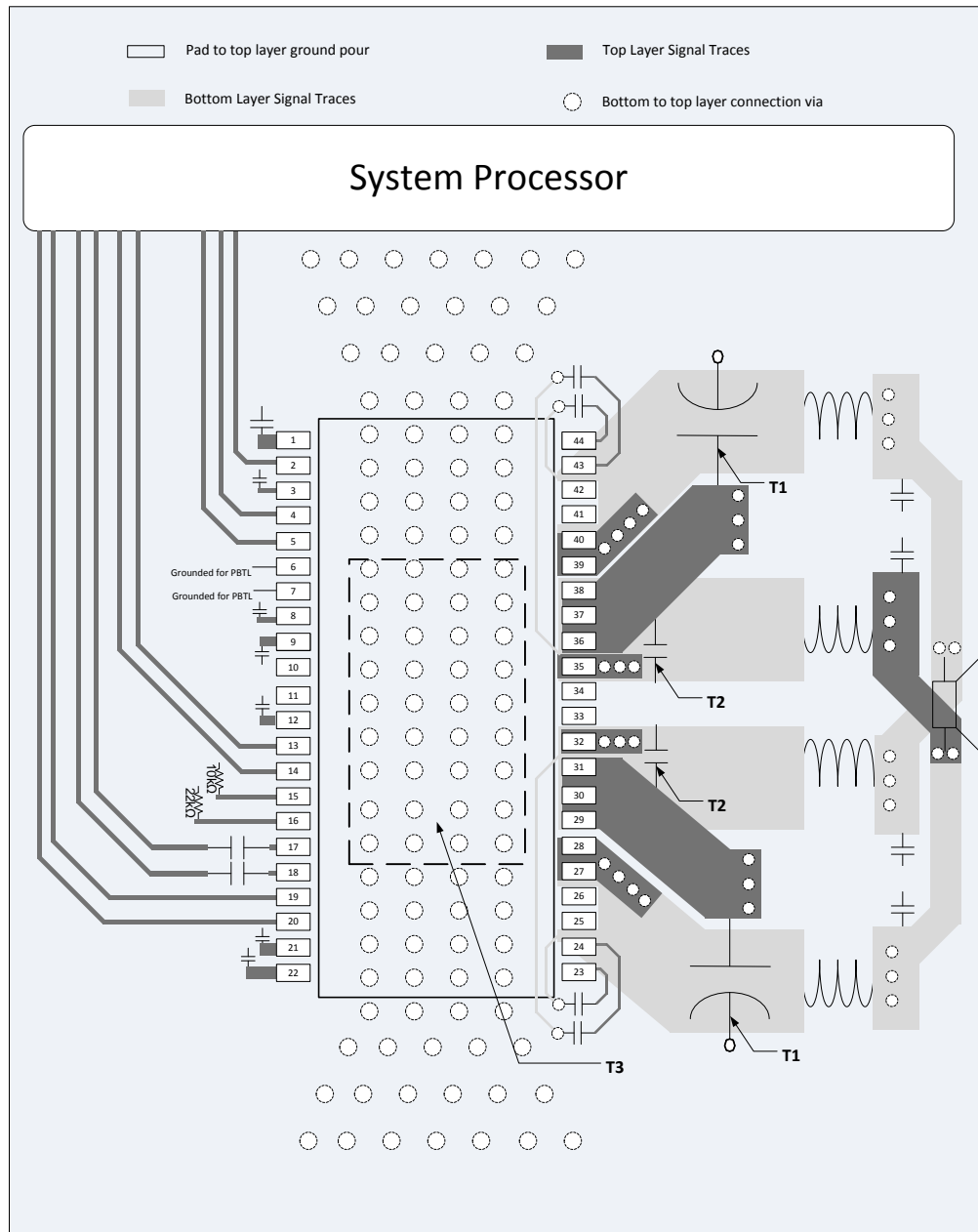

- A. Note: PCB layout example shows composite layout. Dark grey: Top layer copper traces, light gray: Bottom layer copper traces. All PCB area not used for traces should be GND copper pour (transparent on example image)
- B. **Note T1:** PVDD decoupling bulk capacitors should be as close as possible to the PVDD and GND_X pins. Wide traces should be routed on the top layer with direct connection to the pins and without going through vias. No vias or traces should be blocking the current path.
- C. **Note T2:** Close decoupling of PVDD with low impedance X7R ceramic capacitors is placed close to the pins.
- D. **Note T3:** PowerPad™ needs to be soldered to PCB GND copper pour

Figure 37. PBTL (Outputs Paralleled after LC filter) Application Printed Circuit Board - Composite

13 デバイスおよびドキュメントのサポート

13.1 ドキュメントのサポート

『[TPA3244評価モジュール・ユーザー・ガイド](#)』(SLVUAT5)

13.2 ドキュメントの更新通知を受け取る方法

ドキュメントの更新についての通知を受け取るには、ti.comのデバイス製品フォルダを開いてください。右上の隅にある「通知を受け取る」をクリックして登録すると、変更されたすべての製品情報に関するダイジェストを毎週受け取れます。変更の詳細については、修正されたドキュメントに含まれている改訂履歴をご覧ください。

13.3 コミュニティ・リソース

The following links connect to TI community resources. Linked contents are provided "AS IS" by the respective contributors. They do not constitute TI specifications and do not necessarily reflect TI's views; see TI's [Terms of Use](#).

TI E2E™オンライン・コミュニティ *TIのE2E (Engineer-to-Engineer)* コミュニティ。エンジニア間の共同作業を促進するために開設されたものです。e2e.ti.comでは、他のエンジニアに質問し、知識を共有し、アイデアを検討して、問題解決に役立てることができます。

設計サポート *TIの設計サポート* 役に立つE2Eフォーラムや、設計サポート・ツールをすばやく見つけることができます。技術サポート用の連絡先情報も参照できます。

13.4 商標

PurePath, PowerPad, PowerPAD, E2E are trademarks of Texas Instruments.
Blu-Ray Disc is a trademark of Blu-ray Disc Association.
All other trademarks are the property of their respective owners.

13.5 静電気放電に関する注意事項



これらのデバイスは、限定的なESD(静電破壊)保護機能を内蔵しています。保存時または取り扱い時は、MOSゲートに対する静電破壊を防止するために、リード線同士をショートさせておくか、デバイスを導電フォームに入れる必要があります。

13.6 Glossary

[SLYZ022](#) — *TI Glossary*.

This glossary lists and explains terms, acronyms, and definitions.

14 メカニカル、パッケージ、および注文情報

以降のページには、メカニカル、パッケージ、および注文に関する情報が記載されています。この情報は、そのデバイスについて利用可能な最新のデータです。このデータは予告なく変更されることがあり、ドキュメントが改訂される場合もあります。本データシートのブラウザ版を使用されている場合は、画面左側の説明をご覧ください。



PACKAGE OUTLINE

DDW0044D

PowerPAD™ TSSOP - 1.2 mm max height

PLASTIC SMALL OUTLINE

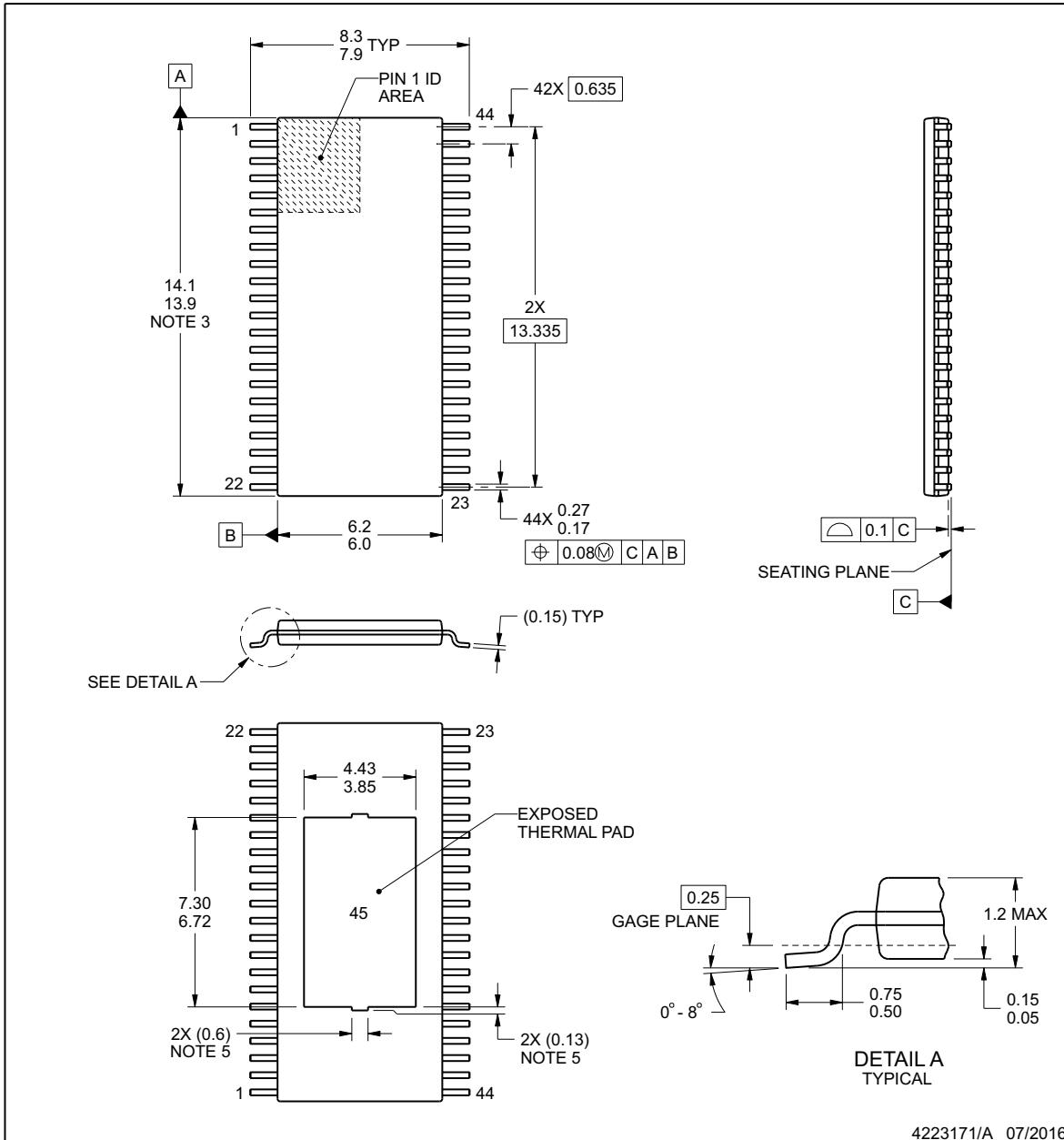

NOTES:

PowerPAD is a trademark of Texas Instruments.

1. All linear dimensions are in millimeters. Any dimensions in parenthesis are for reference only. Dimensioning and tolerancing per ASME Y14.5M.
2. This drawing is subject to change without notice.
3. This dimension does not include mold flash, protrusions, or gate burrs. Mold flash, protrusions, or gate burrs shall not exceed 0.15 mm per side.
4. Reference JEDEC registration MO-153.
5. Features may differ or may not be present.

EXAMPLE BOARD LAYOUT

DDW0044D

PowerPAD™ TSSOP - 1.2 mm max height

PLASTIC SMALL OUTLINE

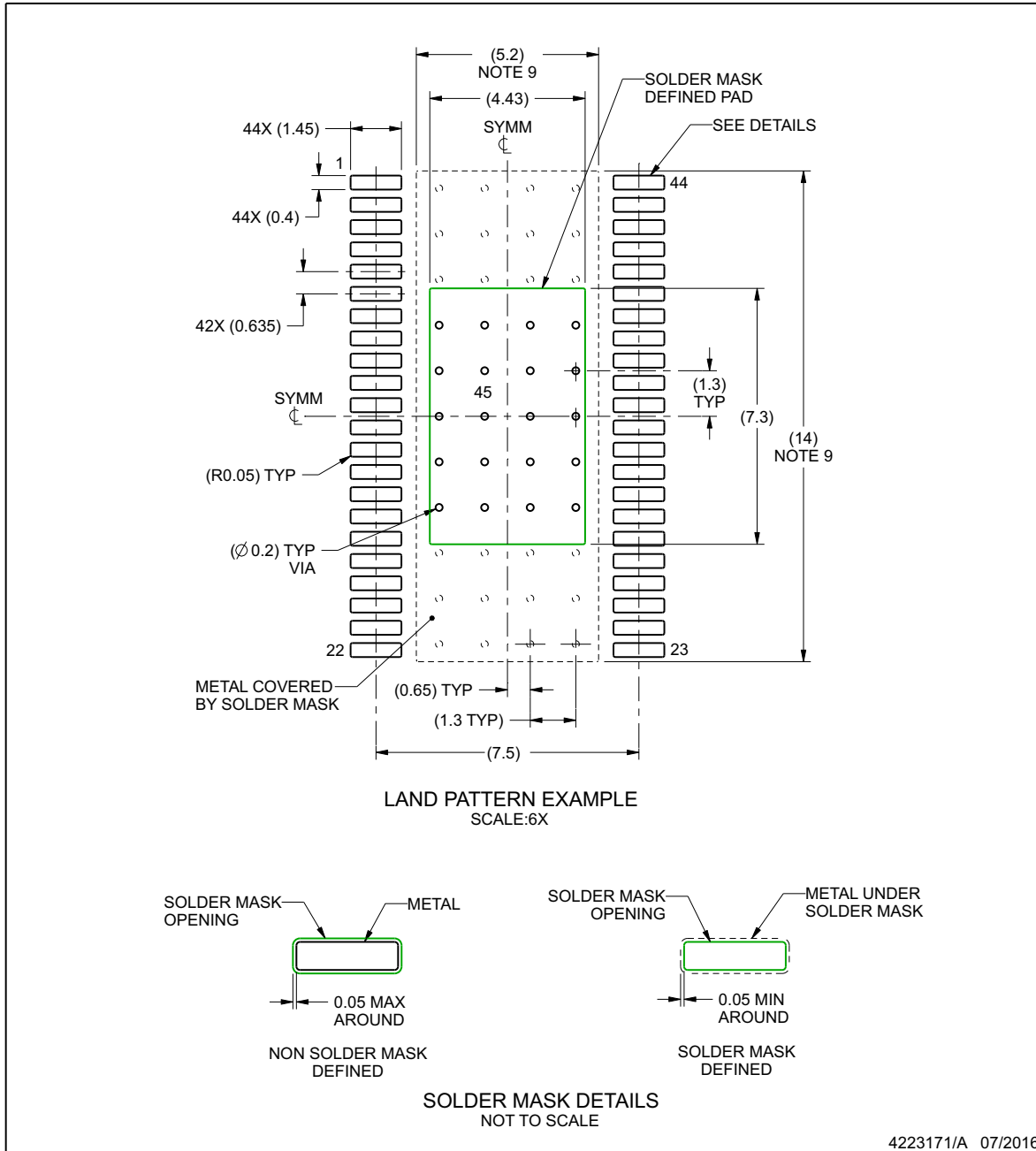

NOTES: (continued)

- 6. Publication IPC-7351 may have alternate designs.
- 7. Solder mask tolerances between and around signal pads can vary based on board fabrication site.
- 8. This package is designed to be soldered to a thermal pad on the board. For more information, see Texas Instruments literature numbers SLMA002 (www.ti.com/lit/slma002) and SLMA004 (www.ti.com/lit/slma004).
- 9. Size of metal pad may vary due to creepage requirement.

EXAMPLE STENCIL DESIGN

DDW0044D

PowerPAD™ TSSOP - 1.2 mm max height

PLASTIC SMALL OUTLINE

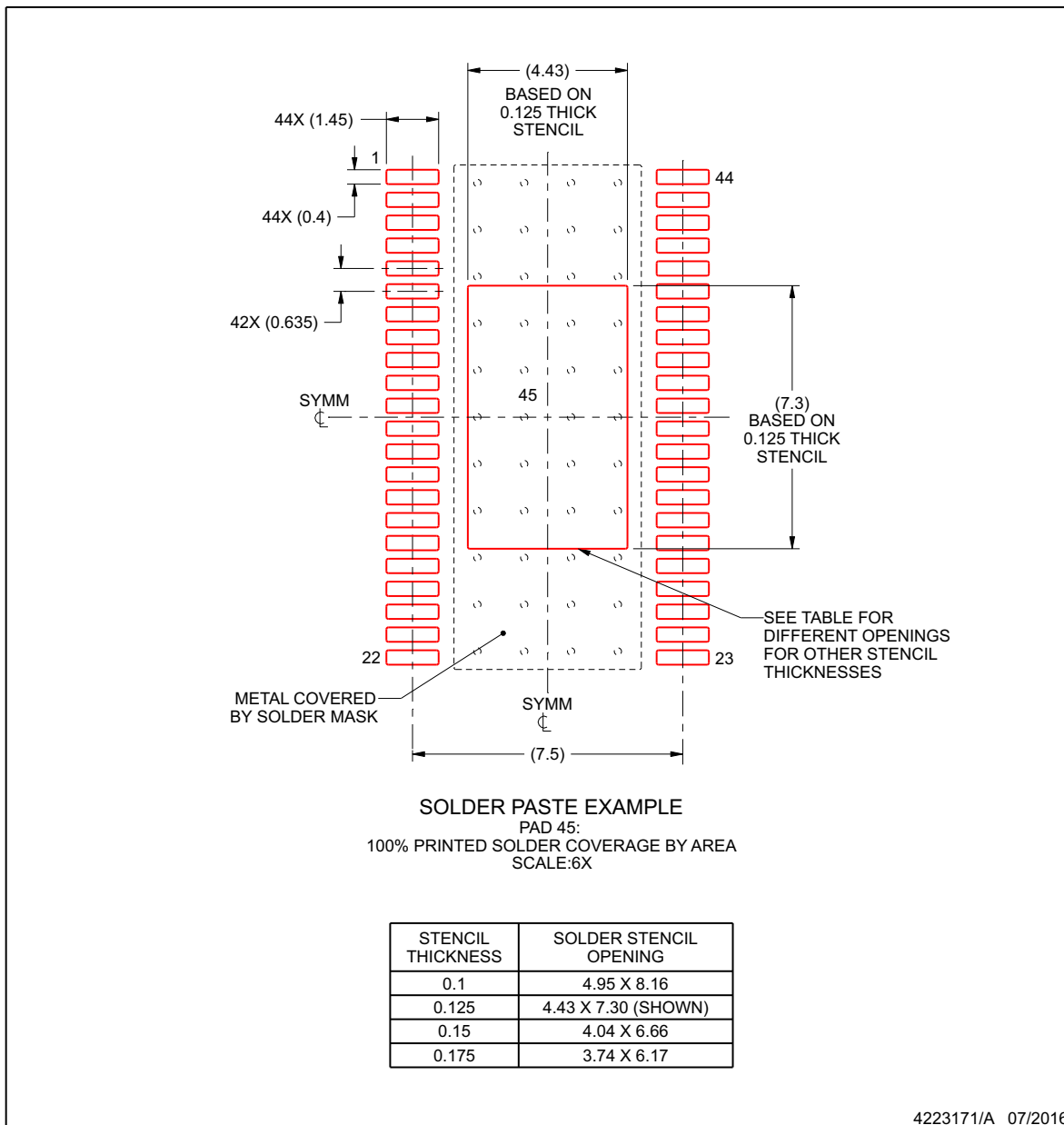

NOTES: (continued)

10. Laser cutting apertures with trapezoidal walls and rounded corners may offer better paste release. IPC-7525 may have alternate design recommendations.
11. Board assembly site may have different recommendations for stencil design.

PACKAGING INFORMATION

Orderable Device	Status (1)	Package Type	Package Drawing	Pins	Package Qty	Eco Plan (2)	Lead finish/ Ball material (6)	MSL Peak Temp (3)	Op Temp (°C)	Device Marking (4/5)	Samples
TPA3244DDW	ACTIVE	HTSSOP	DDW	44	35	RoHS & Green	NIPDAU	Level-3-260C-168 HR	0 to 70	3244	Samples
TPA3244DDWR	ACTIVE	HTSSOP	DDW	44	2000	RoHS & Green	NIPDAU	Level-3-260C-168 HR	0 to 70	3244	Samples

(1) The marketing status values are defined as follows:

ACTIVE: Product device recommended for new designs.

LIFEBUY: TI has announced that the device will be discontinued, and a lifetime-buy period is in effect.

NRND: Not recommended for new designs. Device is in production to support existing customers, but TI does not recommend using this part in a new design.

PREVIEW: Device has been announced but is not in production. Samples may or may not be available.

OBSOLETE: TI has discontinued the production of the device.

(2) **RoHS:** TI defines "RoHS" to mean semiconductor products that are compliant with the current EU RoHS requirements for all 10 RoHS substances, including the requirement that RoHS substance do not exceed 0.1% by weight in homogeneous materials. Where designed to be soldered at high temperatures, "RoHS" products are suitable for use in specified lead-free processes. TI may reference these types of products as "Pb-Free".

RoHS Exempt: TI defines "RoHS Exempt" to mean products that contain lead but are compliant with EU RoHS pursuant to a specific EU RoHS exemption.

Green: TI defines "Green" to mean the content of Chlorine (Cl) and Bromine (Br) based flame retardants meet JS709B low halogen requirements of <=1000ppm threshold. Antimony trioxide based flame retardants must also meet the <=1000ppm threshold requirement.

(3) MSL, Peak Temp. - The Moisture Sensitivity Level rating according to the JEDEC industry standard classifications, and peak solder temperature.

(4) There may be additional marking, which relates to the logo, the lot trace code information, or the environmental category on the device.

(5) Multiple Device Markings will be inside parentheses. Only one Device Marking contained in parentheses and separated by a "~" will appear on a device. If a line is indented then it is a continuation of the previous line and the two combined represent the entire Device Marking for that device.

(6) Lead finish/Ball material - Orderable Devices may have multiple material finish options. Finish options are separated by a vertical ruled line. Lead finish/Ball material values may wrap to two lines if the finish value exceeds the maximum column width.

Important Information and Disclaimer:The information provided on this page represents TI's knowledge and belief as of the date that it is provided. TI bases its knowledge and belief on information provided by third parties, and makes no representation or warranty as to the accuracy of such information. Efforts are underway to better integrate information from third parties. TI has taken and continues to take reasonable steps to provide representative and accurate information but may not have conducted destructive testing or chemical analysis on incoming materials and chemicals. TI and TI suppliers consider certain information to be proprietary, and thus CAS numbers and other limited information may not be available for release.

In no event shall TI's liability arising out of such information exceed the total purchase price of the TI part(s) at issue in this document sold by TI to Customer on an annual basis.

TAPE AND REEL INFORMATION

QUADRANT ASSIGNMENTS FOR PIN 1 ORIENTATION IN TAPE

*All dimensions are nominal

Device	Package Type	Package Drawing	Pins	SPQ	Reel Diameter (mm)	Reel Width W1 (mm)	A0 (mm)	B0 (mm)	K0 (mm)	P1 (mm)	W (mm)	Pin1 Quadrant
TPA3244DDWR	HTSSOP	DDW	44	2000	330.0	24.4	8.6	15.6	1.8	12.0	24.0	Q1

TAPE AND REEL BOX DIMENSIONS

*All dimensions are nominal

Device	Package Type	Package Drawing	Pins	SPQ	Length (mm)	Width (mm)	Height (mm)
TPA3244DDWR	HTSSOP	DDW	44	2000	350.0	350.0	43.0

TUBE

*All dimensions are nominal

Device	Package Name	Package Type	Pins	SPQ	L (mm)	W (mm)	T (μm)	B (mm)
TPA3244DDW	DDW	HTSSOP	44	35	530	11.89	3600	4.9

重要なお知らせと免責事項

TI は、技術データと信頼性データ (データシートを含みます)、設計リソース (リファレンス・デザインを含みます)、アプリケーションや設計に関する各種アドバイス、Web ツール、安全性情報、その他のリソースを、欠陥が存在する可能性のある「現状のまま」提供しており、商品性および特定目的に対する適合性の黙示保証、第三者の知的財産権の非侵害保証を含むいかなる保証も、明示的または黙示的にかかわらず拒否します。

これらのリソースは、TI 製品を使用する設計の経験を積んだ開発者への提供を意図したものです。(1) お客様のアプリケーションに適した TI 製品の選定、(2) お客様のアプリケーションの設計、検証、試験、(3) お客様のアプリケーションに該当する各種規格や、その他のあらゆる安全性、セキュリティ、規制、または他の要件への確実な適合に関する責任を、お客様のみが単独で負うものとし、

上記の各種リソースは、予告なく変更される可能性があります。これらのリソースは、リソースで説明されている TI 製品を使用するアプリケーションの開発の目的でのみ、TI はその使用をお客様に許諾します。これらのリソースに関して、他の目的で複製することや掲載することは禁止されています。TI や第三者の知的財産権のライセンスが付与されている訳ではありません。お客様は、これらのリソースを自身で使用した結果発生するあらゆる申し立て、損害、費用、損失、責任について、TI およびその代理人を完全に補償するものとし、TI は一切の責任を拒否します。

TI の製品は、[TI の販売条件](#)、または [ti.com](https://www.ti.com) やかかる TI 製品の関連資料などのいずれかを通じて提供する適用可能な条項の下で提供されています。TI がこれらのリソースを提供することは、適用される TI の保証または他の保証の放棄の拡大や変更を意味するものではありません。

お客様がいかなる追加条項または代替条項を提案した場合でも、TI はそれらに異議を唱え、拒否します。

郵送先住所 : Texas Instruments, Post Office Box 655303, Dallas, Texas 75265
Copyright © 2023, Texas Instruments Incorporated