

TMUXHS4612 3.3V 6 チャンネル 20Gbps、差動 2:1 マルチプレクサ / 1:2 デマルチプレクサ

1 特長

- HDMI 1.4b/2.0/2.1 で最大 12Gbps、USB4 で最大 20Gbps、DisplayPort 1.4/2.1 で最大 UHBR20 をサポート
- 最大 20Gbps のデータ伝送能力
- 高速パスは広い同相電圧範囲 (0V~V_{CC}) をサポート
- 高速データピン用に 8.8Ω (標準値) の低い R_{ON}
- 高速データピン用 13.0GHz の -3dB 差動 BW
- 優れた動的特性 (10GHz 時):
 - 挿入損失: -2.5dB
 - 反射損失: -13dB
 - クロストーク: -30dB
- すべてのサイドバンド信号は、最大 5V レベルのパススルーが可能で 5.5V に対応
- 1.8V および 3.3V の制御ロジックをサポート
- 3.3V の単一電源電圧
- アクティブ時 (800μA)、スタンバイ時 (32μA) の低消費電流
- 電源レールが消失 (V_{CC} = 0V) した場合の電流リークを防止する I_{OFF} 保護
- 温度範囲: -40°C ~ 125°C
- パッケージ: 40 ピン、3mm × 6mm、0.4mm ピッチの WQFN

2 アプリケーション

- PC とノート PC
- ゲーム、ホームシアター、エンターテインメント、TV
- データセンターおよびエンタープライズコンピューティング
- 医療用アプリケーション
- 試験および測定機器
- ファクトリオートメーション / 制御
- 航空宇宙および防衛
- 電子 POS (EPOS)

- [ワイヤレスインフラ](#)

3 概要

TMUXHS4612 は、マルチプレクサまたはデマルチプレクサ構成の高速、双方向パッシブスイッチです。このデバイスはプロトコルに依存せず、HDMI 1.4/2.0/2.1、DisplayPort 1.4/2.1 など多くのアプリケーションをサポートします。TMUXHS4612 は、最高 20Gbps のデータレートでの多数の高速差動インターフェイスに使用できる汎用アナログ差動パッシブマルチプレクサ / デマルチプレクサです。TMUXHS4612 高速チャンネルは、シングルエンド信号が V_{P-N_ABSMAX} パラメータに違反しない限り、差動信号とシングルエンド信号をサポートします。サイドバンドチャンネルは 5V に対応し、I²C、UART、DisplayPort AUX、USB2 などのシングルエンド信号と差動信号をサポートしています。高速チャンネルの動的特性により、信号アイダイアグラムの最小限の減衰で高速スイッチングが可能であり、発生するジッタも非常に低いレベルに抑えられます。このデバイスのシリコン設計は、高い周波数の信号帯域でも優れた周波数応答が得られるように最適化されています。このデバイスは、Dxx データパスで 0V ~ 3.6V の同相電圧範囲 (CMV) を持つ差動信号をサポートしています。

TMUXHS4612 は、アクティブ状態において 800μA という非常に低い消費電力を実現しています。本デバイスにはパワーダウンモードも備わっており、このモードでは、すべてのチャンネルがハイインピーダンス状態となり、デバイスはわずか 32μA の最小電力で動作します。

パッケージ情報

部品番号	温度	パッケージ ⁽¹⁾	パッケージサイズ ⁽²⁾
TMUXHS4612	T _A = 0°C ~ 105°C	RET (WQFN, 40)	6mm × 3mm
TMUXHS4612I	T _A = -40°C ~ 125°C		

- (1) 供給されているすべてのパッケージについては、[セクション 11](#) を参照してください。
- (2) パッケージサイズ (長さ×幅) は公称値であり、該当する場合はピンも含まれます。

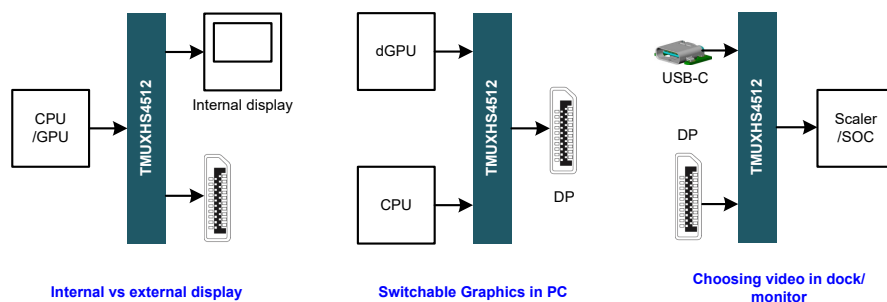

概略使用事例

Table of Contents

1 特長	1	7.4 Device Functional Modes.....	14
2 アプリケーション	1	8 Application and Implementation	15
3 概要	1	8.1 Application Information.....	15
4 Pin Configuration and Functions	3	8.2 Typical Application - HDMI.....	15
5 Specifications	5	8.3 Power Supply Recommendations.....	18
5.1 Absolute Maximum Ratings.....	5	8.4 Layout.....	18
5.2 ESD Ratings.....	5	8.5 Systems Examples.....	19
5.3 Recommended Operating Conditions.....	5	9 Device and Documentation Support	24
5.4 Thermal Information.....	6	9.1 Documentation Support.....	24
5.5 Electrical Characteristics.....	6	9.2 ドキュメントの更新通知を受け取る方法.....	24
5.6 High-Speed Performance Parameters.....	7	9.3 サポート・リソース.....	24
5.7 Switching Characteristics.....	7	9.4 Trademarks.....	24
5.8 Typical Characteristics.....	9	9.5 静電気放電に関する注意事項.....	24
6 Parameter Measurement Information	10	9.6 用語集.....	24
7 Detailed Description	13	10 Revision History	24
7.1 Overview.....	13	11 Mechanical, Packaging, and Orderable Information	24
7.2 Functional Block Diagram.....	13		
7.3 Feature Description.....	14		

4 Pin Configuration and Functions



図 4-1. RET Package 40-Pin WQFN With Exposed Thermal Pad (Top View)

表 4-1. Pin Functions

PIN		TYPE	DESCRIPTION
NAME	NO.		
EN	1	I	Device Enable L: Device Disabled. All data and sideband signals in Hi-Z. H: Device Enabled. All data and sideband signals selected by D_AB_SEL and SIDEBAND_SEL are enabled.
D_AB_SEL	2	I	Selects between high-speed datapath A and B. L: High-speed datapath A H: High-speed datapath B
SIDEBAND_SEL	3	I	Selects between sideband path A and B L: Sideband path A H: Sideband path B
D0-	4	I/O	Common Port, Channel 0, -ve signal
D0+	5	I/O	Common Port, Channel 0, +ve signal
D1-	6	I/O	Common Port, Channel 1, -ve signal
D1+	7	I/O	Common Port, Channel 1, +ve signal

表 4-1. Pin Functions (続き)

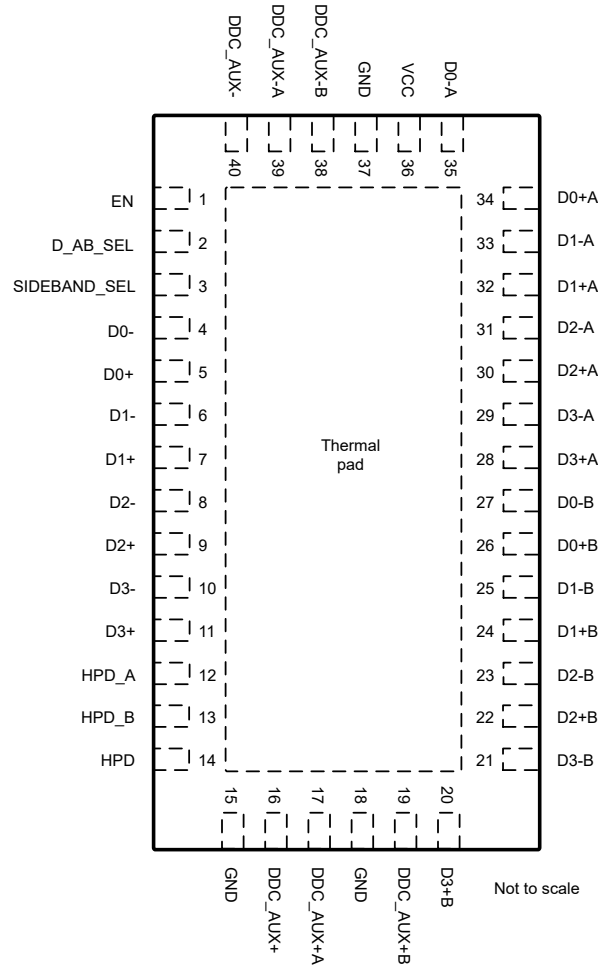
PIN		TYPE	DESCRIPTION
NAME	NO.		
D2–	8	I/O	Common Port, Channel 2, –ve signal
D2+	9	I/O	Common Port, Channel 2, +ve signal
D3–	10	I/O	Common Port, Channel 3, –ve signal
D3+	11	I/O	Common Port, Channel 3, +ve signal
HPD_A	12	I/O	Port A, Hot Plug Detect sideband signal
HPD_B	13	I/O	Port B, Hot Plug Detect sideband signal
HPD	14	I/O	Common Port, Hot Plug Detect sideband signal
GND	15	GND	Ground
DDC_AUX+	16	I/O	Common Port, DDC or AUX sideband signal
DDC_AUX+A	17	I/O	Port A, DDC or AUX sideband signal
GND	18	GND	Ground
DDC_AUX+B	19	I/O	Port B, DDC or AUX sideband signal
D3+B	20	I/O	Port B, Channel 3, +ve signal
D3–B	21	I/O	Port B, Channel 3, –ve signal
D2+B	22	I/O	Port B, Channel 2, +ve signal
D2–B	23	I/O	Port B, Channel 2, –ve signal
D1+B	24	I/O	Port B, Channel 1, +ve signal
D1–B	25	I/O	Port B, Channel 1, –ve signal
D0+B	26	I/O	Port B, Channel 0, +ve signal
D0–B	27	I/O	Port B, Channel 0, –ve signal
D3+A	28	I/O	Port A, Channel 3, +ve signal
D3–A	29	I/O	Port A, Channel 3, –ve signal
D2+A	30	I/O	Port A, Channel 2, +ve signal
D2–A	31	I/O	Port A, Channel 2, –ve signal
D1+A	32	I/O	Port A, Channel 1, +ve signal
D1–A	33	I/O	Port A, Channel 1, –ve signal
D0+A	34	I/O	Port A, Channel 0, +ve signal
D0–A	35	I/O	Port A, Channel 0, –ve signal
VCC	36	Power	Supply Voltage
GND	37	GND	Ground
DDC_AUX-B	38	I/O	Port B, DDC or AUX sideband signal
DDC_AUX-A	39	I/O	Port A, DDC or AUX sideband signal
DDC_AUX-	40	I/O	Common Port, DDC or AUX sideband signal
GND	PowerPad	GND	Ground

5 Specifications

5.1 Absolute Maximum Ratings

over operating free-air temperature range (unless otherwise noted)⁽¹⁾

			MIN	MAX	UNIT
V _{CC_ABSMAX}	Supply voltage range		-0.5	4.0	V
V _{I/O_ABSMAX}	Analog voltage range ^{(2) (3) (4)}	All high-speed data I/O pins	-0.5	4.0	V
V _{I/O_ABSMAX}	Analog voltage range ^{(2) (3) (4)}	All sideband ⁽⁵⁾ pins	-0.5	6.0	V
V _{IN_ABSMAX}	Digital input voltage range ^{(2) (3)}	All control pins ⁽⁶⁾	-0.5	5.0	V
V _{P_N_ABSMAX}	Absolute value of positive pin minus negative pin	All high-speed data I/O pins		0.8	V
T _{Jmax}	Maximum junction temperature TMUXHS4612		0	105	°C
T _{Jmax}	Maximum junction temperature TMUXHS4612I		-40	125	°C
T _{stg}	Storage temperature range		-65	150	°C

- (1) Operation outside the *Absolute Maximum Ratings* may cause permanent device damage. Absolute Maximum Ratings do not imply functional operation of the device at these or any other conditions beyond those listed under *Recommended Operating Conditions*. If used outside the Recommended Operating Conditions but within the Absolute Maximum Ratings, the device may not be fully functional, and this may affect device reliability, functionality, performance, and shorten the device lifetime.
- (2) All voltages are with respect to ground, unless otherwise specified.
- (3) The input and output voltage ratings may be exceeded if the input and output clamp-current ratings are observed.
- (4) V_I and V_O are used to denote specific conditions for V_{I/O}.
- (5) Sideband pins: DDC_AUX+A, DDC_AUX-A, HPD_A, DDC_AUX+B, DDC_AUX-B, HPD_B, DDC_AUX+, DDC_AUX-, HPD
- (6) Control pins: D_AB_SEL, SIDEBAND_SEL, EN

5.2 ESD Ratings

			VALUE	UNIT
V _(ESD)	Electrostatic discharge	Human body model (HBM), per ANSI/ESDA/JEDEC JS-001, ⁽¹⁾	±1500	V
		Charged device model (CDM), per ANSI/ESDA/JEDEC JS-002, ⁽²⁾	±750	

- (1) JEDEC document JEP155 states that 500V HBM allows safe manufacturing with a standard ESD control process.
- (2) JEDEC document JEP157 states that 250V CDM allows safe manufacturing with a standard ESD control process.

5.3 Recommended Operating Conditions

over operating free-air temperature range (unless otherwise noted)⁽¹⁾

		MIN	TYP	MAX	UNIT
V _{CC}	Supply voltage	3.0	3.3	3.6	V
V _{I/O,CM}	Input/Output common mode voltage (data pins)	0		3.6	V
V _{I/O}	Input/Output voltage data pins	0		3.6	V
V _{I/O}	Input/Output voltage sideband ⁽²⁾ pins	0		5	V
V _{IN}	Digital input voltage (control ⁽³⁾ pins)	0		V _{CC}	V
DR	Data rate for differential signals			20	Gbps
T _A	Operating ambient temperature TMUXHS4612	0		105	°C
T _A	Operating ambient temperature TMUXHS4612I	-40		125	°C
T _J	Operating junction temperature TMUXHS4612	0		110	°C
T _J	Operating junction temperature TMUXHS4612I	-40		125	°C

- (1) All unused control inputs of the device must be held at V_{CC} or GND to ensure proper device operation. For more information, see [Implications of Slow or Floating CMOS Inputs](#) application note.
- (2) Sideband pins: DDC_AUX+A, DDC_AUX-A, HPD_A, DDC_AUX+B, DDC_AUX-B, HPD_B, DDC_AUX+, DDC_AUX-, HPD
- (3) Control pins: D_AB_SEL, SIDEBAND_SEL, EN

5.4 Thermal Information

THERMAL METRIC ⁽¹⁾		TMUXHS4612	UNIT
		RET	
		40 PINS	
R _{θJA}	Junction-to-ambient thermal resistance	33.0	°C/W
R _{θJC(top)}	Junction-to-case (top) thermal resistance	25.4	°C/W
R _{θJB}	Junction-to-board thermal resistance	12.2	°C/W
ψ _{JT}	Junction-to-top characterization parameter	0.8	°C/W
ψ _{JB}	Junction-to-board characterization parameter	12.2	°C/W
R _{θJC(bot)}	Junction-to-case (bottom) thermal resistance	3.1	°C/W

(1) For more information about traditional and new thermal metrics, see the [Semiconductor and IC Package Thermal Metrics](#) application note.

5.5 Electrical Characteristics

over operating free-air temperature range (unless otherwise noted)

PARAMETER ^{(3) (4)}			TEST CONDITIONS ⁽¹⁾	MIN	TYP ⁽²⁾	MAX	UNIT
DC Characteristics (data and sideband)							
R _{ON-D}	ON-state resistance	All data pins;	V _{I/O} = 0V to VCC; I _{I/O} = -10mA; VCC = 3.3V ±10%; 0 to 85°C;	8.8	11		Ω
			V _{I/O} = 0V to VCC; I _{I/O} = -10mA; VCC = 3.3V ±10%; -40 to 125°C;	8.8	12		Ω
R _{ON-SB}	ON-state resistance	All sideband pins;	V _{I/O} = 0V to VCC; I _{I/O} = -10mA; VCC = 3.3V ±10%; 0 to 85°C;	8.2	15		Ω
			V _{I/O} = 0V to VCC; I _{I/O} = -10mA; VCC = 3.3V ±10%; -40 to 125°C;	8.2	16		Ω
R _{ON-SB-5V}	ON-state resistance	All sideband pins;	V _{I/O} = 5V; I _{I/O} = -10 mA; VCC = 3.3V ±10%; -40 to 125°C;	65	110		Ω
C _{ON-SB-100K}	Sideband ON capacitance to GND		f = 100kHz;			8	pF
C _{OFF-SB-100K}	Sideband Off capacitance to GND		f = 100kHz;			5	pF
C _{ON-SB-1M}	Sideband ON capacitance to GND		f = 1MHz;			7	pF
C _{OFF-SB-1M}	Sideband Off capacitance to GND		f = 1MHz;			4.5	pF
I _{IH-D}	Input current for high-speed data pair	All selected data pins.	EN = H; V _{I/O} = 3.3V; VCC = 3.3V ±10%;			4	μA
		All non-selected data pins.	EN = H; V _{I/O} = 3.3V; VCC = 3.3V ±10%;			70	μA
I _{IH-SB}	Input current for sideband	All selected sideband pins.	EN = H; V _{I/O} = 3.3V; VCC = 3.3V ±10%;			5	μA
		All non-selected sideband pins.	EN = H; V _{I/O} = 3.3V; VCC = 3.3V ±10%;			1	μA
I _{OFF-DAB}	Leakage under power off (failsafe current)	All data pins	VCC = 0V; V _{I/O} = 0V to 3.3V; All common pins are pulled up to 3.3V and A side and B side are at GND.	-20		100	μA
I _{OFF-SB}	Leakage under power off (failsafe current)	All sideband pins	VCC = 0V; V _{I/O} = 0V to 5.5V;	-1		5	μA
Control Inputs (SIDEBAND_SEL, D_AB_SEL, EN)							
V _{IH-CTRL}	High-level input voltage for control pins	Per pin for all control pins.	VCC = 3.3V ±10%;	1.4			V
V _{IL-CTRL}	Low-level input voltage for control pins	Per pin for all control pins.	VCC = 3.3V ±10%;			0.5	V
I _{IH-CTRL}	Input high leakage current for control pins	Per pin for all control pins.	VCC = 3.6V; V _{IN} = 3.6V;	-0.1		0.1	μA
I _{IL-CTRL}	Input low leakage current for control pins	Per pin for all control pins.	VCC = 3.6V; V _{IN} = 0V;	-0.1		0.1	μA
I _{OFF-CTRL}	Leakage under power off (failsafe current)	Per pin for all control pins.	VCC = 0V; V _{IN} = 0V or 3.6V;	-0.1		0.1	μA
C _{IN-CTRL}	Input capacitance	Per pin for all control pins.	f = 1MHz;			5	pF

over operating free-air temperature range (unless otherwise noted)

PARAMETER ^{(3) (4)}		TEST CONDITIONS ⁽¹⁾	MIN	TYP ⁽²⁾	MAX	UNIT
Power Supply						
I _{CC}	VCC supply current in active mode	EN = H; V _{I/O} = 0V or VCC;			800	μA
I _{CC-PD}	VCC supply current in power-down mode	EN = L; V _{I/O} = 0V or VCC;		0.04	32	μA

(1) V_I, V_O, I_I, and I_O refer to data and sideband I/O pins. V_{IN} refers to the control inputs.

(2) All typical values are at V_{CC} = 3.3V (unless otherwise noted), T_A = 25°C.

(3) Sideband pins: DDC_AUX+A, DDC_AUX-A, HPD_A, DDC_AUX+B, DDC_AUX-B, HPD_B, DDC_AUX+, DDC_AUX-, HPD

(4) Control pins: D_AB_SEL, SIDEBAND_SEL, EN

5.6 High-Speed Performance Parameters

over recommended operation free-air temperature range, (unless otherwise noted). For all data pins. R_L = 50Ω where applicable.

PARAMETER		TEST CONDITIONS	MIN	TYP ⁽¹⁾	MAX	UNIT
BW _{SB}	Sideband pins differential bandwidth (–3dB from DC)			2.0		GHz
BW _{HS}	High-speed pins differential bandwidth (–3dB from DC)			13		GHz
IL _{DAB}	Differential insertion loss	At 100MHz; VCM = 0V;		–0.7		dB
		At 1.7GHz; VCM = 0V;		–1.0		dB
		At 2.7GHz; VCM = 0V;		–1.1		dB
		At 4.0GHz; VCM = 0V;		–1.2		dB
		At 6.0GHz; VCM = 0V;		–1.6		dB
		At 10.0GHz; VCM = 0V;		–2.5		dB
RL _{DAB}	Differential return loss	At 100MHz; VCM = 0V;		–23		dB
		At 1.7GHz; VCM = 0V;		–22		dB
		At 2.7GHz; VCM = 0V;		–20		dB
		At 4.0GHz; VCM = 0V;		–19		dB
		At 6.0GHz; VCM = 0V;		–18		dB
		At 10.0GHz; VCM = 0V;		–13		dB
Xtalk	Differential crosstalk	At 100MHz; VCM = 0V;		–66		dB
		At 1.7GHz; VCM = 0V;		–40		dB
		At 2.7GHz; VCM = 0V;		–37		dB
		At 4.0GHz; VCM = 0V;		–44		dB
		At 6.0GHz; VCM = 0V;		–45		dB
		At 10.0GHz; VCM = 0V;		–30		dB
OISO	Differential off isolation	At 100MHz; VCM = 0V;		–65		dB
		At 1.7GHz; VCM = 0V;		–37		dB
		At 2.7GHz; VCM = 0V;		–33		dB
		At 4.0GHz; VCM = 0V;		–30		dB
		At 6.0GHz; VCM = 0V;		–27		dB
		At 10.0GHz; VCM = 0V;		–23		dB

(1) All Typical Values are at V_{CC} = 3.3V (unless otherwise noted), T_A = 25°C.

5.7 Switching Characteristics

PARAMETER		MIN	TYP	MAX	UNIT
Device Switching Time					
t _{SW_POWER_ON}	Device power ON time	EN pin from L to H;		200	μs
t _{SW_POWER_OFF}	Device power OFF time	EN pin from H to L;		400	ns
High Speed Pins					
t _{PD}	Switch differential propagation delay	f = 1GHz	60		ps

PARAMETER			MIN	TYP	MAX	UNIT
t _{SW_AB}	Switching time from A to B	Measured from 50% of select to 50% of VOH/VOL			40	μs
t _{SW_BA}	Switching time from B to A	Measured from 50% of select to 50% of VOH/VOL			40	μs
t _{SK_INTRA}	Intra-pair output skew between + and - pins for same channel	f = 1GHz		1.8	6	ps
t _{SK_INTER}	Inter-pair output skew between channels	f = 1GHz			8	ps
Sideband Pins						
t _{PD-SB}	Switch single-ended propagation delay	f = 1MHz			250	ps
t _{SW-SB_AB}	Switching time from A to B	Measured from 50% of select to 50% of VOH/VOL			20	μs
t _{SW-SB_BA}	Switching time from B to A	Measured from 50% of select to 50% of VOH/VOL			20	μs
t _{SK-SB}	Output skew between DDC_AUX+ and DDC_AUX- pins	f = 1MHz			8	ps

5.8 Typical Characteristics

Data taken from a single unit under nominal power supply and temperature conditions with $V_{I/O,CM}$ at 0V.

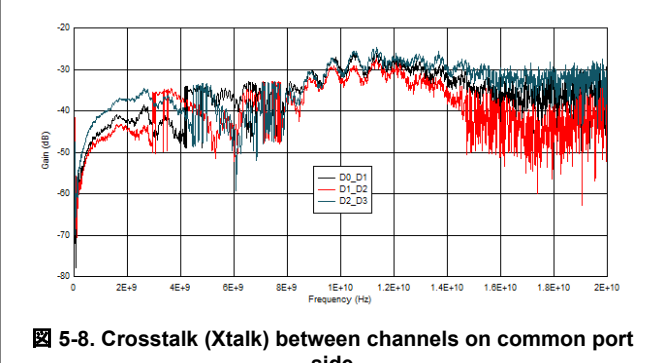
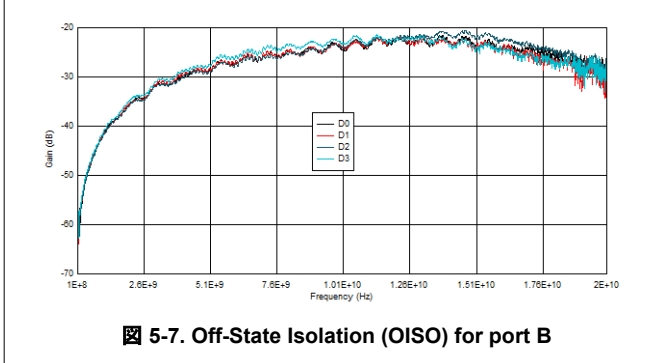
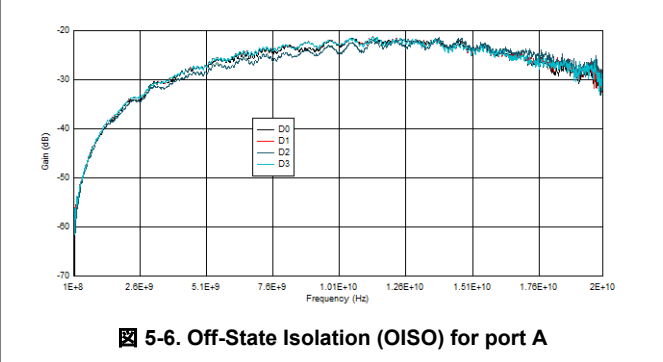
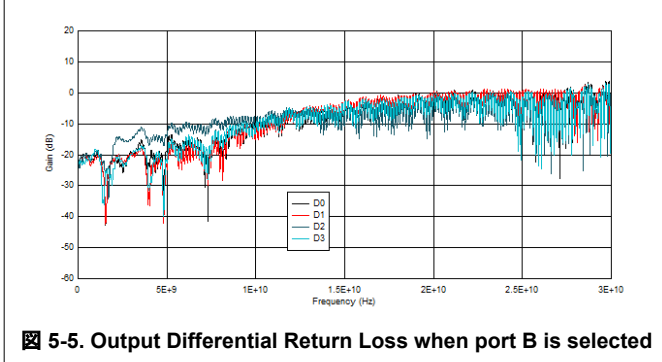
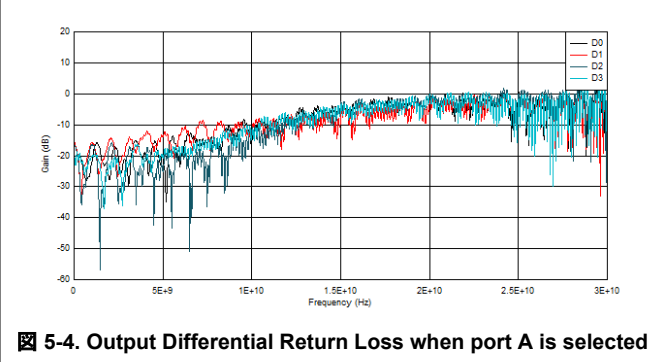
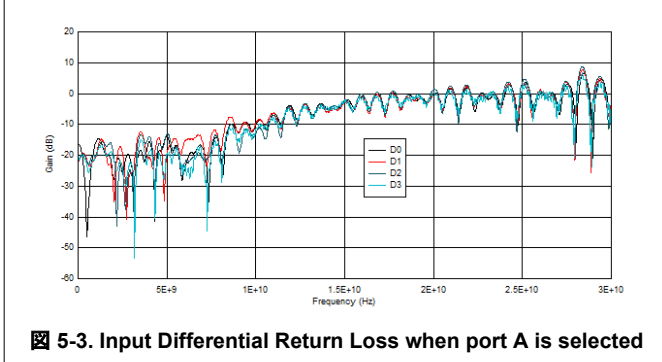
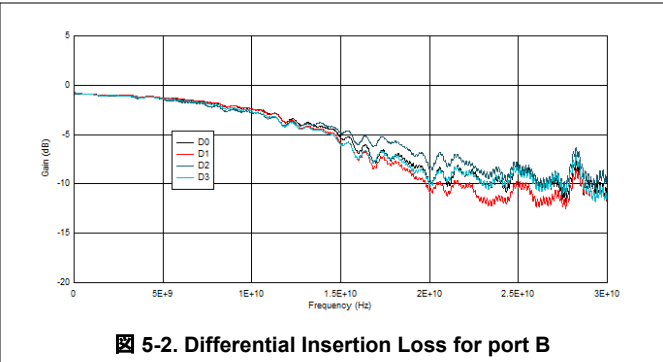
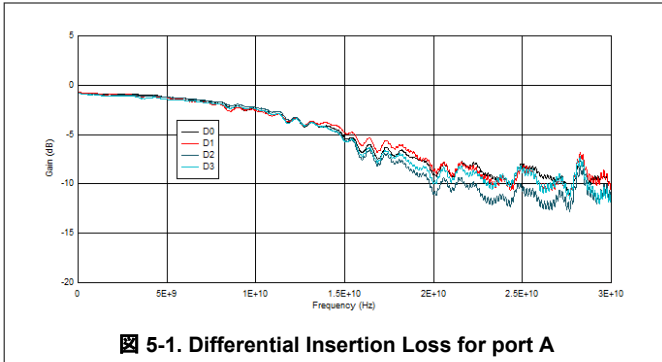

6 Parameter Measurement Information

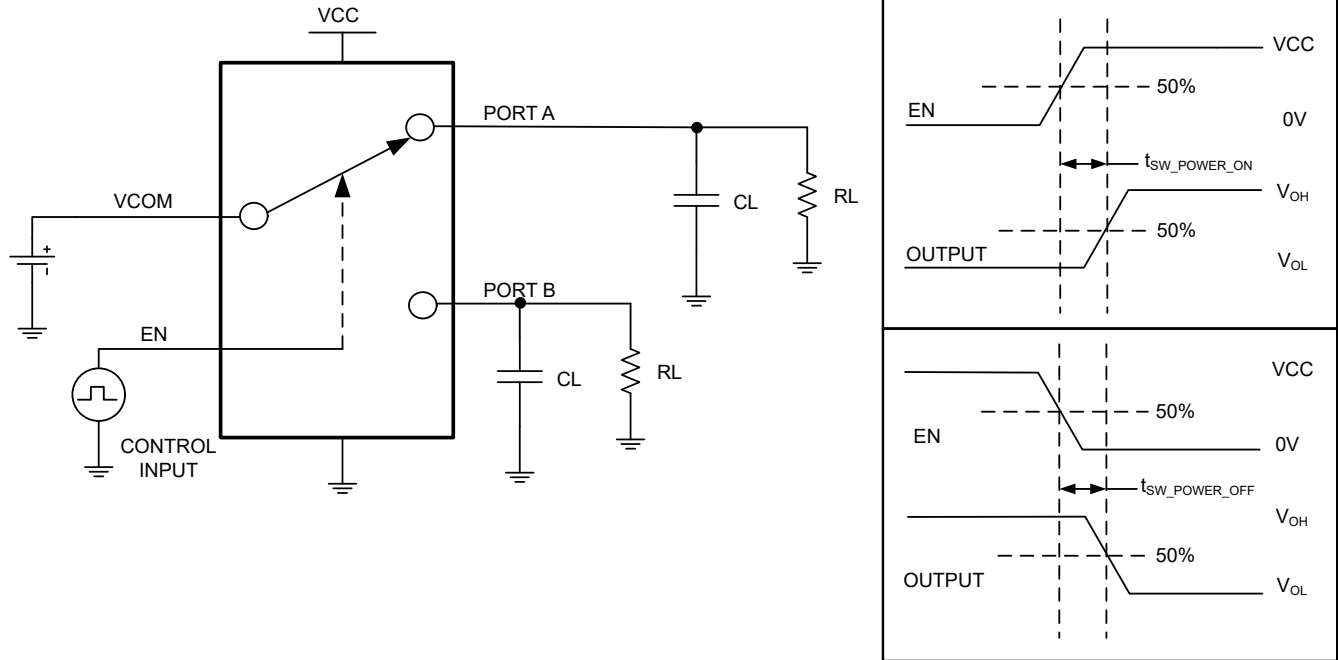

NOTE: $R_L = 10k\Omega$; $V_{COM} = V_{CC}$; $C_L = 1pF$

図 6-1. Switch Turn-On Time ($t_{SW_POWER_ON}$ and $t_{SW_POWER_OFF}$)

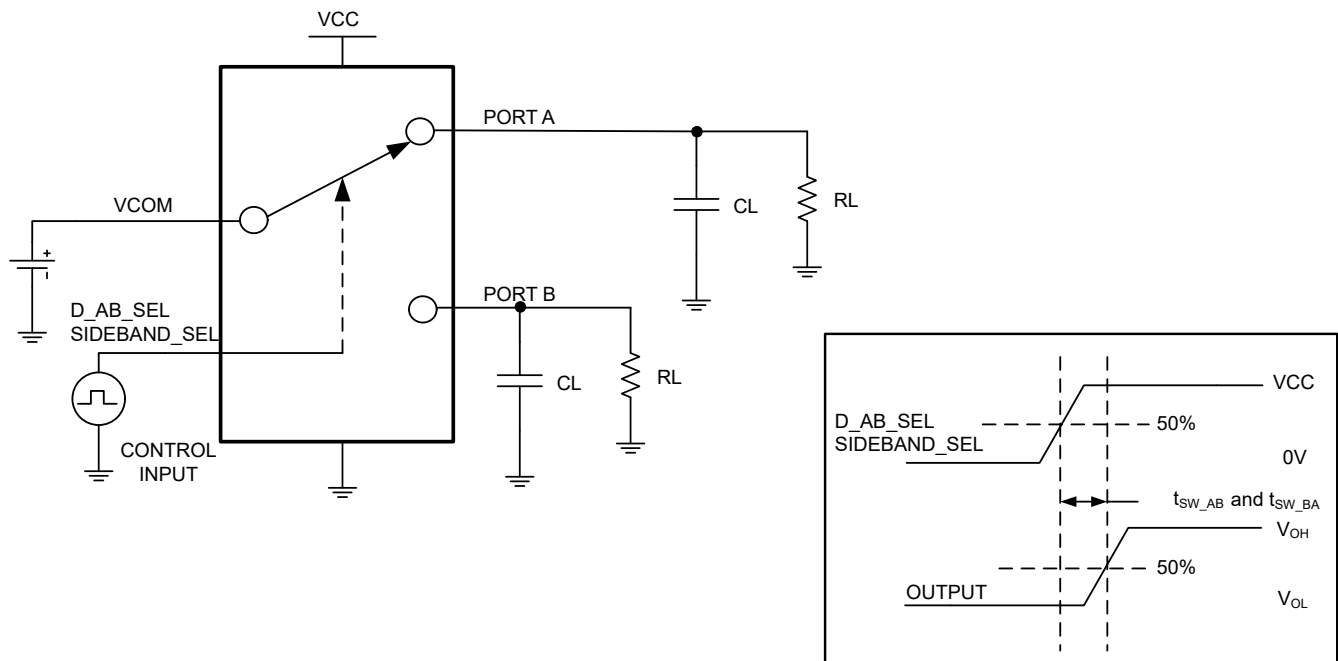

$R_L = 10k\Omega$; $V_{COM} = V_{CC}$; $C_L = 1pF$

図 6-2. Switching Time Between Channels (t_{SW_AB} and t_{SW_BA})



図 6-3. Propagation Delay (t_{pd})



図 6-4. Crosstalk (Xtalk)

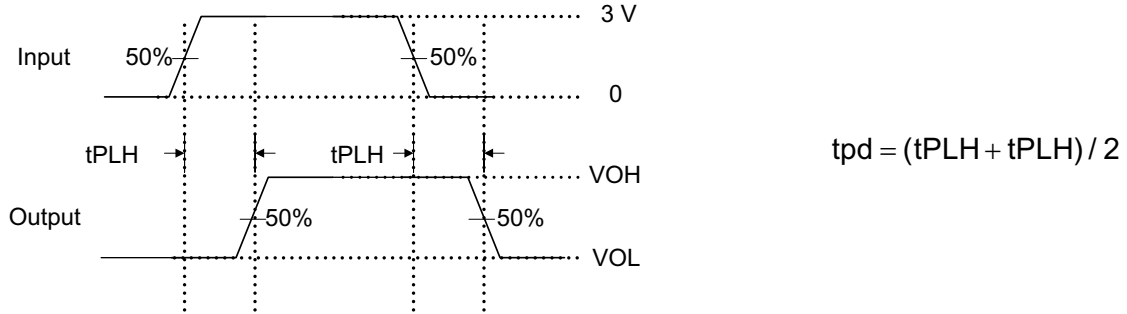

図 6-5. Differential Off-Isolation (OISO)

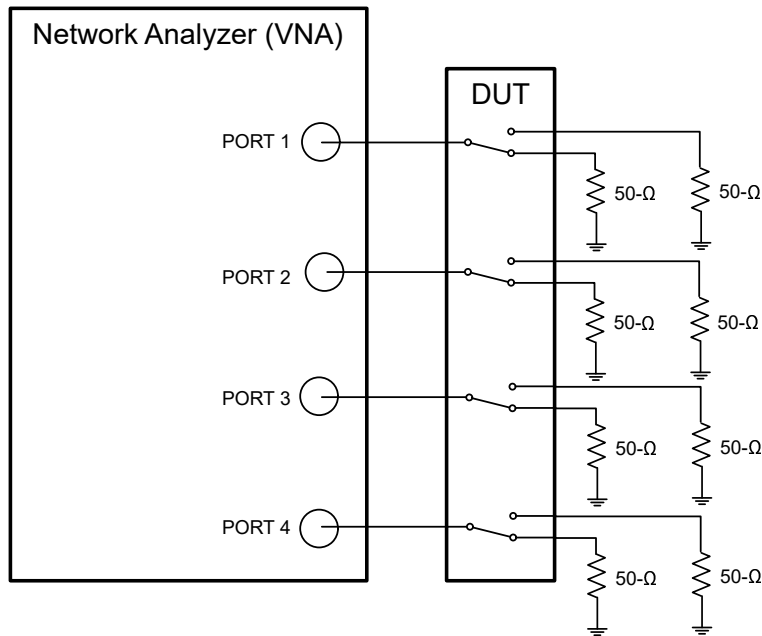

図 6-6. Differential Bandwidth (BW), Insertion Loss, and Return Loss

7 Detailed Description

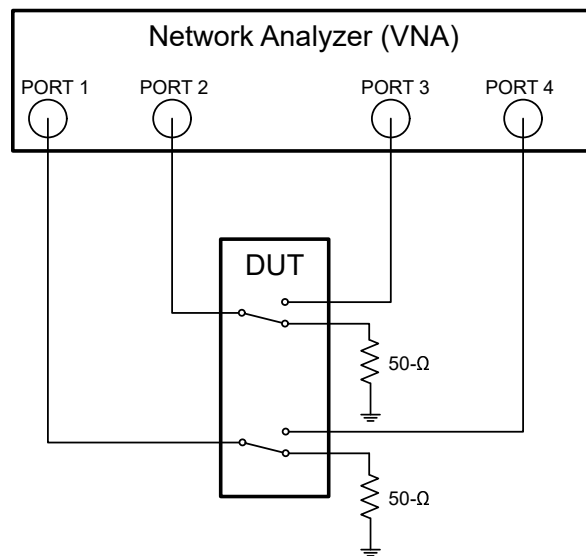
7.1 Overview

The TMUXHS4612 is a protocol agnostic bidirectional multiplexer/demultiplexer that offers low on-state resistance as well as low I/O capacitance, which allows the device to achieve a high bandwidth of 13.0GHz typical for differential channels. The TMUXHS4612 is a passive mux that is recommended for data rates up to 20Gbps. However, the device can be used for interfaces with higher data rates if overall electrical link loss permits. The high-speed data channels of the device provide the high bandwidth necessary for many interfaces to handle differential as well as single-ended signals as long as the single-ended signals do not violate V_{P-N_ABSMAX} . The high-speed channels of the device support differential signaling with common-mode voltage range (CMV) of 0V to 3.6V that can be used in high common-mode interfaces such as HDMI. The sideband channels are 5V tolerant. The sideband channels support 0V to 3.6V CMOS signals with a typical R_{ON} of 8.5Ω and 5V CMOS signals with a typical R_{ON} of 65Ω.

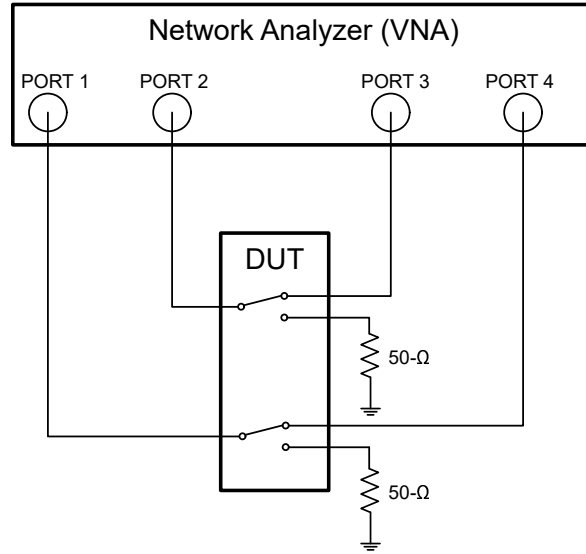
7.2 Functional Block Diagram

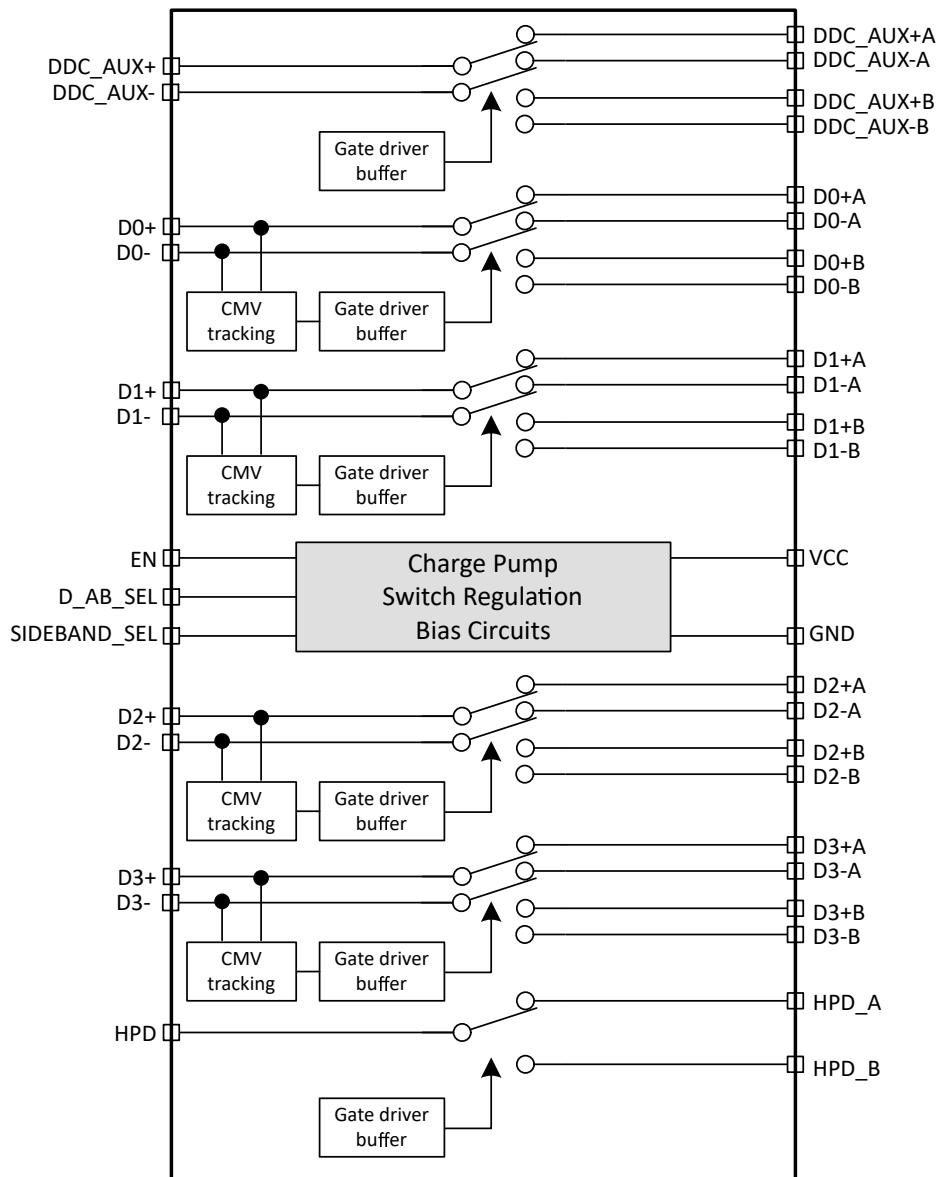

7.3 Feature Description

The TMUXHS4612 is based on proprietary TI technology which uses FET switches driven by a high-voltage generated from an integrated charge-pump to achieve a low on-state resistance. The TMUXHS4612's low power technology uses only 800 μ A in active and just 32 μ A in powerdown (EN = L) mode. The device has integrated ESD that can support up to 1.5kV Human-Body Model (HBM) and 750V Charge Device Model (CDM). The TMUXHS4612 also has a special feature that prevents the device from back-powering when the V_{CC} supply is not available and an analog signal is applied on the I/O pin. In this situation this special feature prevents leakage current in the device. The TMUXHS4612 is not designed for passing signals with negative swings.

7.4 Device Functional Modes

表 7-1 lists the device functions for the TMUXHS4612 device.

表 7-1. Functional Table

EN	D_AB_SEL	SIDEBAND_SEL	FUNCTION
L	X	X	Switch disabled. All channels are Hi-Z.
H	L	L	All A channels are enabled. All B channels are Hi-Z.
H	L	H	All A data high-speed channels are enabled and B sideband channels are enabled. All other channels are Hi-Z.
H	H	L	All B data high-speed channels are enabled and A sideband channels are enabled. All other channels are Hi-Z.
H	H	H	All B channels are enabled. All A channels are Hi-Z.

8 Application and Implementation

注

以下のアプリケーション情報は、TI の製品仕様に含まれるものではなく、TI ではその正確性または完全性を保証いたしません。個々の目的に対する製品の適合性については、お客様の責任で判断していただくこととなります。お客様は自身の設計実装を検証しテストすることで、システムの機能を確認する必要があります。

8.1 Application Information

The TMUXHS4612 is a generic analog differential passive mux or demux that works for many high-speed differential interfaces with data rates up to 20Gbps. The TMUXHS4612 supports differential signaling with common-mode voltage range (CMV) of 0V to 3.6V and with differential amplitude up to 1600mVpp in Dxx channels. The device can be also used for single-ended CMOS signals with swing limited to 0V to 3.6V in sideband channels. The TMUXHS4612 can be used as mux or demux switch for:

- HDMI 1.4 up to 3.4Gbps, HDMI 2.0 up to 6Gbps and HDMI 2.1 up to 12Gbps
- DisplayPort (DP) for up to UHBR20 for data rates up to 20Gbps
- USB4 and Thunderbolt (TBT) 3 or 4 for data rates up to 20Gbps

8.2 Typical Application - HDMI

The TMUXHS4612 can be used to switch HDMI signals in both source and sink applications. In source applications HDMI port from a graphics processor can be demultiplexed into one of the two HDMI connectors. In a PC the TMUXHS4612 can be used to switch integrated graphics versus discrete graphics to a connector. In a sink application the device also can be used to select between two HDMI connectors to provide HDMI signals into a scaler (SOC) in HDMI sink application. This section provides detailed design implementation for a sink application where TMUXHS4612 provides 2:1 demultiplexing function.

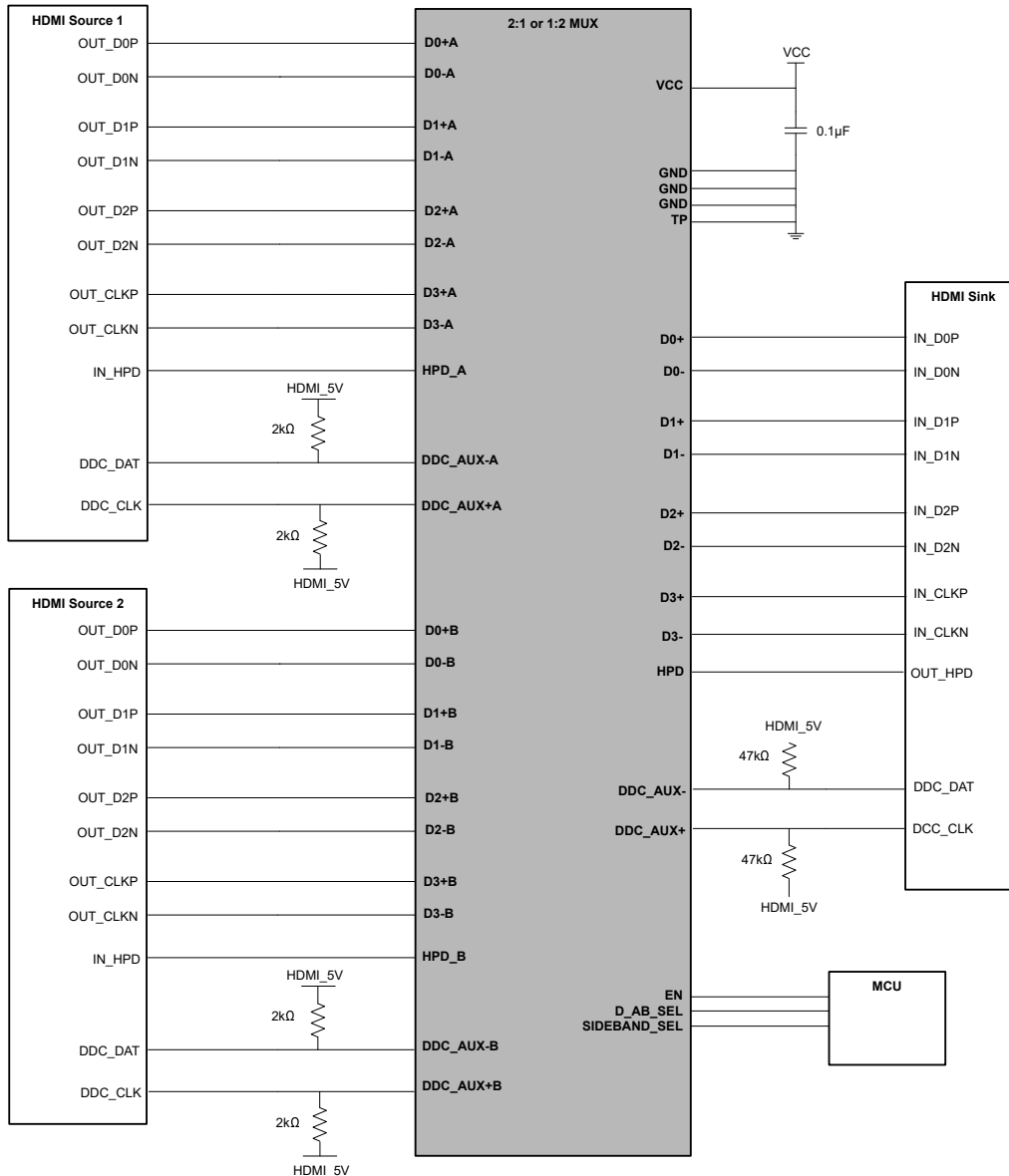

☒ 8-1. Choosing One of Two HDMI Port - Application Schematic

8.2.1 Design Requirements

表 8-1 lists the design parameters for this HDMI example.

表 8-1. Design Parameters for HDMI Application

Design parameter	Example value
V _{CC}	3V to 3.6V
VCC decoupling capacitor	0.1µF
DDC Pullup resistors	Sink Side: 47kΩ to 5V Source Side: 2kΩ to 5V

8.2.2 Detailed Design Procedure

The TMUXHS4612 is designed to operate with 3.0V to 3.6V power supply. Decoupling capacitors can be used to reduce noise and improve power supply integrity. Pullup resistors to 5V must be placed on the source side DDC clock and data lines according to the HDMI standard.

In the HDMI standard the DDC clock, DDC data, and HPD lines are at 5V levels. In some use cases the HDMI source or sink may not be able to handle 5V levels. If this is the case, then an external level shifter must be deployed in order to level shift the HDMI signals to an acceptable level. [Figure 8-2](#) shows an example implementation of an I²C level shifter such as Texas Instruments TCA9517. In this example the HDMI sources are subjected to HDMI levels up to VCC_A (such as 3.3V) instead of HDMI 5V.

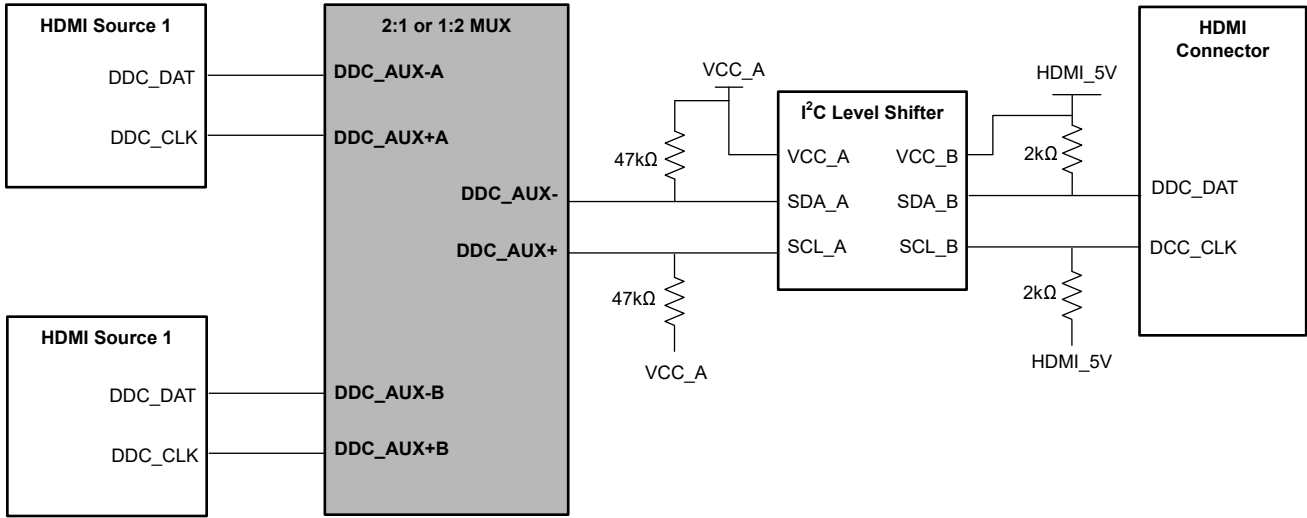

Figure 8-2. DDC level shifter source side example

8.2.3 Application Curves

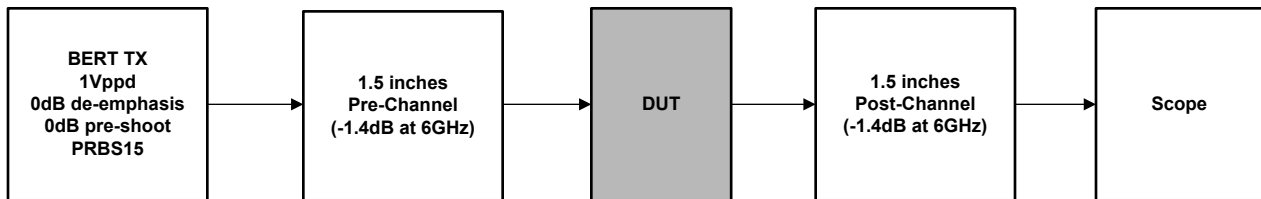
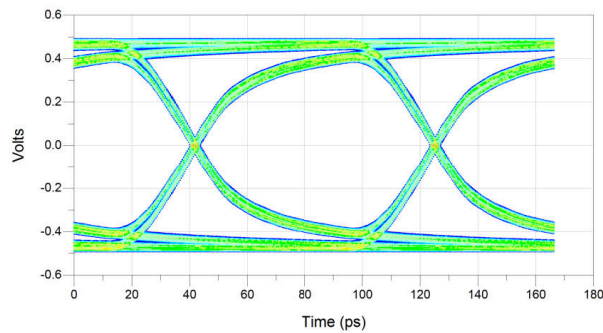
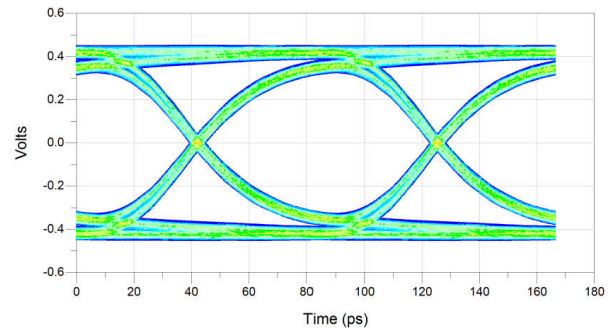

Figure 8-3. Test Setup



8-4. Eye Pattern: 12Gbps, No Device Through Path (Only One Channel Measured at a Time)



8-5. Eye Pattern: 12Gbps Port B, D0+ to D0+B, D0- to D0-B (Only One Channel Measured at a Time)

8.3 Power Supply Recommendations

Keep the V_{CC} in the range of 3.0V to 3.6V. Do not use voltage levels above those listed in the *Absolute Maximum Ratings* table. Use decoupling capacitors to reduce noise and improve power supply integrity. There are no power sequence requirements for the TMUXHS4612.

8.4 Layout

8.4.1 Layout Guidelines

To ensure reliability of the device, the following commonly used printed circuit board layout guidelines are recommended:

- Use decoupling capacitors between power supply pin and ground pin to ensure low impedance to reduce noise. To achieve a low impedance over a wide frequency range use capacitors with a high self-resonance frequency.
- Place ESD and EMI protection devices (if used) as close as possible to the connector.
- Use short trace lengths to avoid excessive loading.
- Keep traces at least two times the trace width apart to minimize the effects of crosstalk on adjacent traces.
- Separate high-speed signals from low-speed signals and digital from analog signals
- Avoid right-angle bends in a trace and try to route them at least with two 45° corners.
- Route the high-speed differential signal traces parallel to each other as much as possible. The traces are recommended to be symmetrical.
- Place a solid ground plane next to the high-speed signal layer. This also provides an excellent low-inductance path for the return current flow.

8.4.2 Layout Example

The TMUXHS4612 application with a single controller interfacing between a common port and two separate ports.



図 8-6. Layout Example

8.5 Systems Examples

8.5.1 DisplayPort 2:1 Multiplexing

The TMUXHS4612 supports AC-coupled interfaces such as DisplayPort. External ac-coupling capacitors must be used on either the common side or the non-common side of the device. In this particular example, the external AC-coupling capacitors are placed on the non-common side. The common side is DC-coupled to the DP

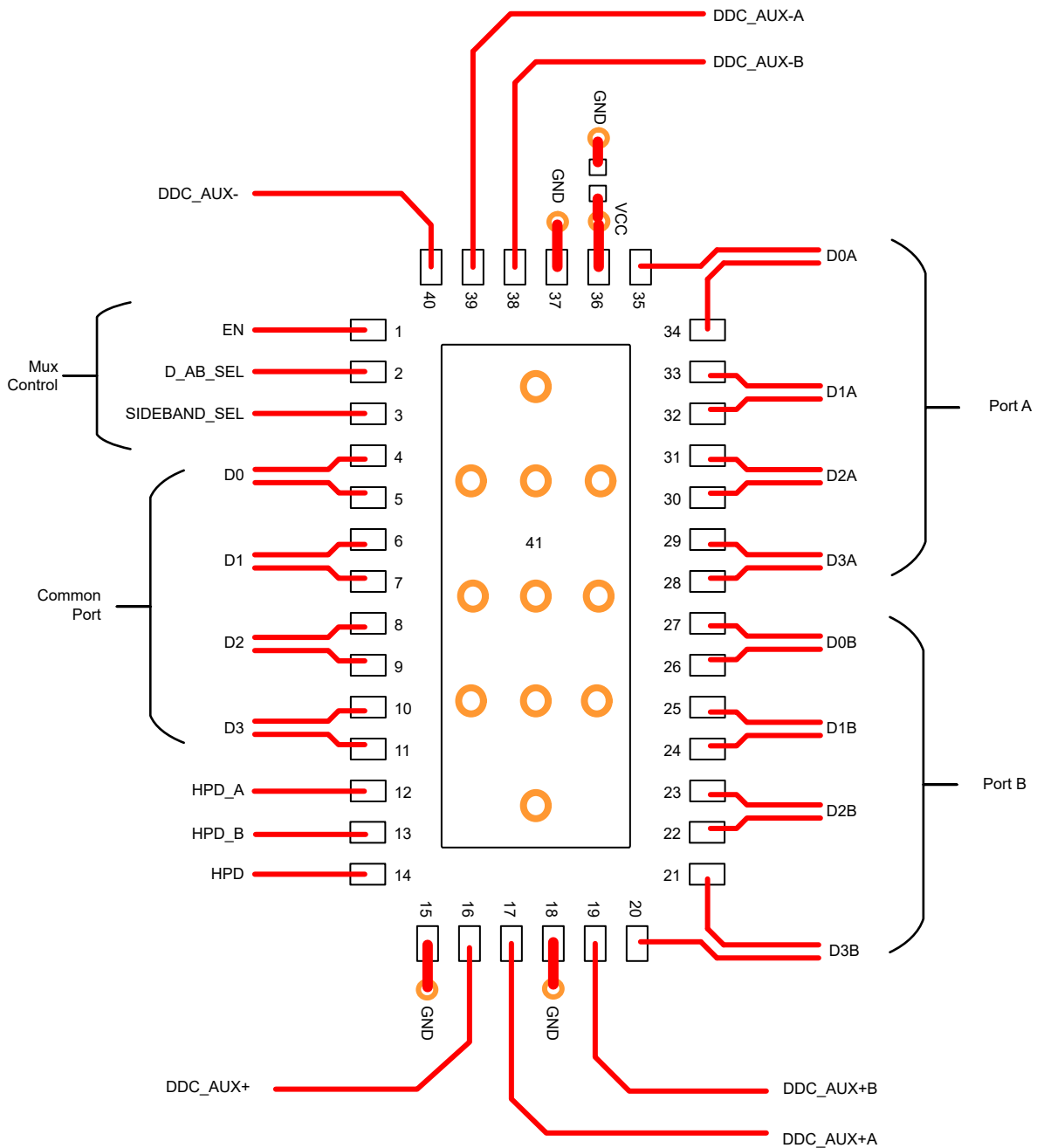
sink. The choice of DC-coupling the non-common side or the common side is based on which DP source or DP sink meets the $V_{IO,CM}$ requirement of the device. If the DP source does not comply to the $V_{IO,CM}$ requirement, then place the AC-coupling capacitors between the DP source and TMUXHS4612. If the DP sink does not comply to the $V_{IO,CM}$ requirement, then place the AC-coupling capacitors between the DP sink and TMUXHS4612.

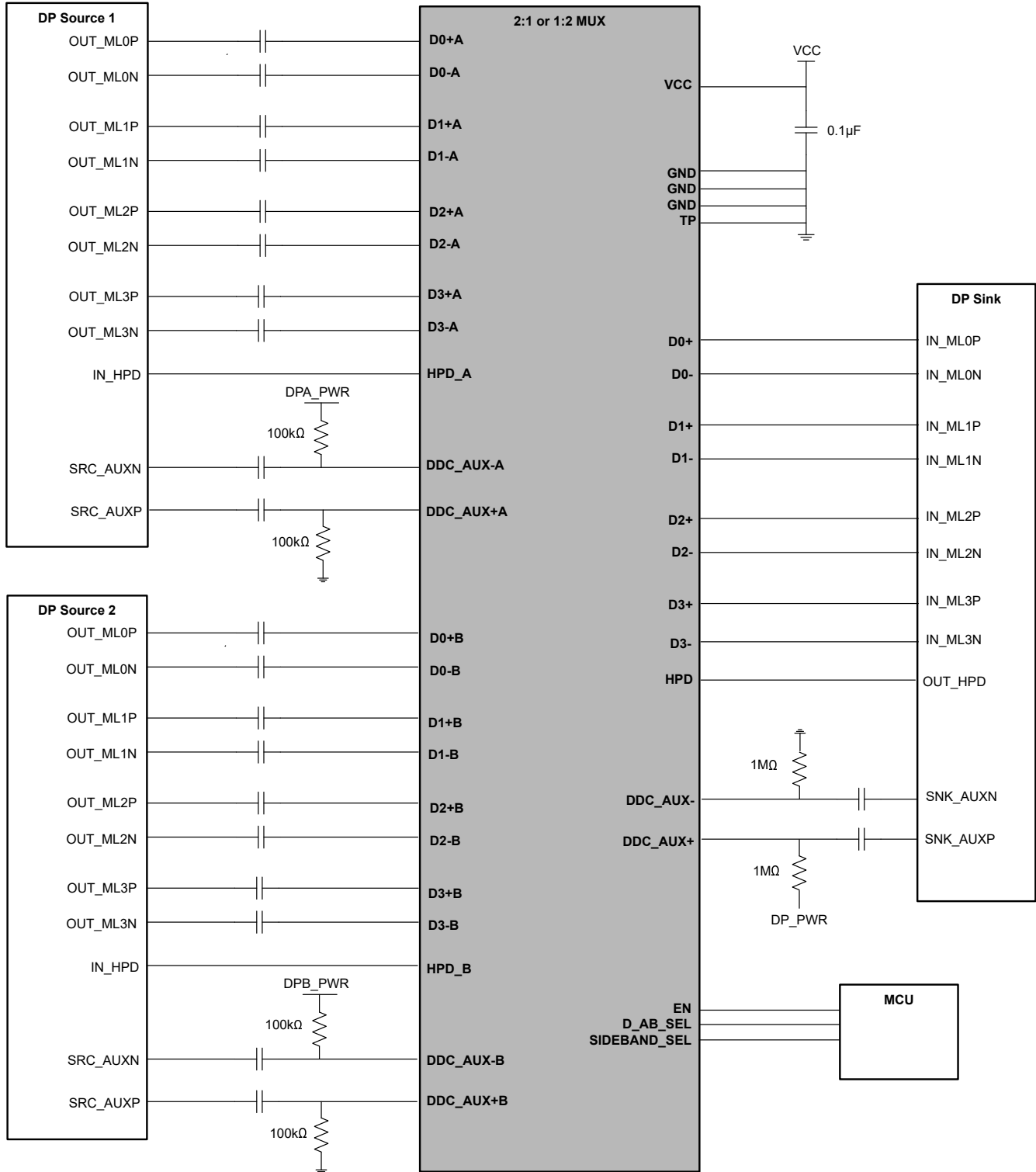

8-7. DisplayPort 2:1 Switching

8.5.2 DisplayPort 1:2 Multiplexing

The TMUXHS4612 supports AC-coupled interfaces such as DisplayPort. External AC-coupling capacitors must be used on either the common side or the non-common side of the device. In this particular example, the

external AC-coupling capacitors are placed on the common side. The non-common side is DC-coupled to the DP sinks. The choice of DC-coupling the non-common side or the common side is based on which DP source or DP sink meets the $V_{IO,CM}$ requirements of the device. If the DP source does not comply to the $V_{IO,CM}$ requirement, then place the AC-coupling capacitors between the DP source and TMUXHS4612. If the DP sink does not comply to the $V_{IO,CM}$ requirement, then place the AC-coupling capacitors between the DP sink and TMUXHS4612.

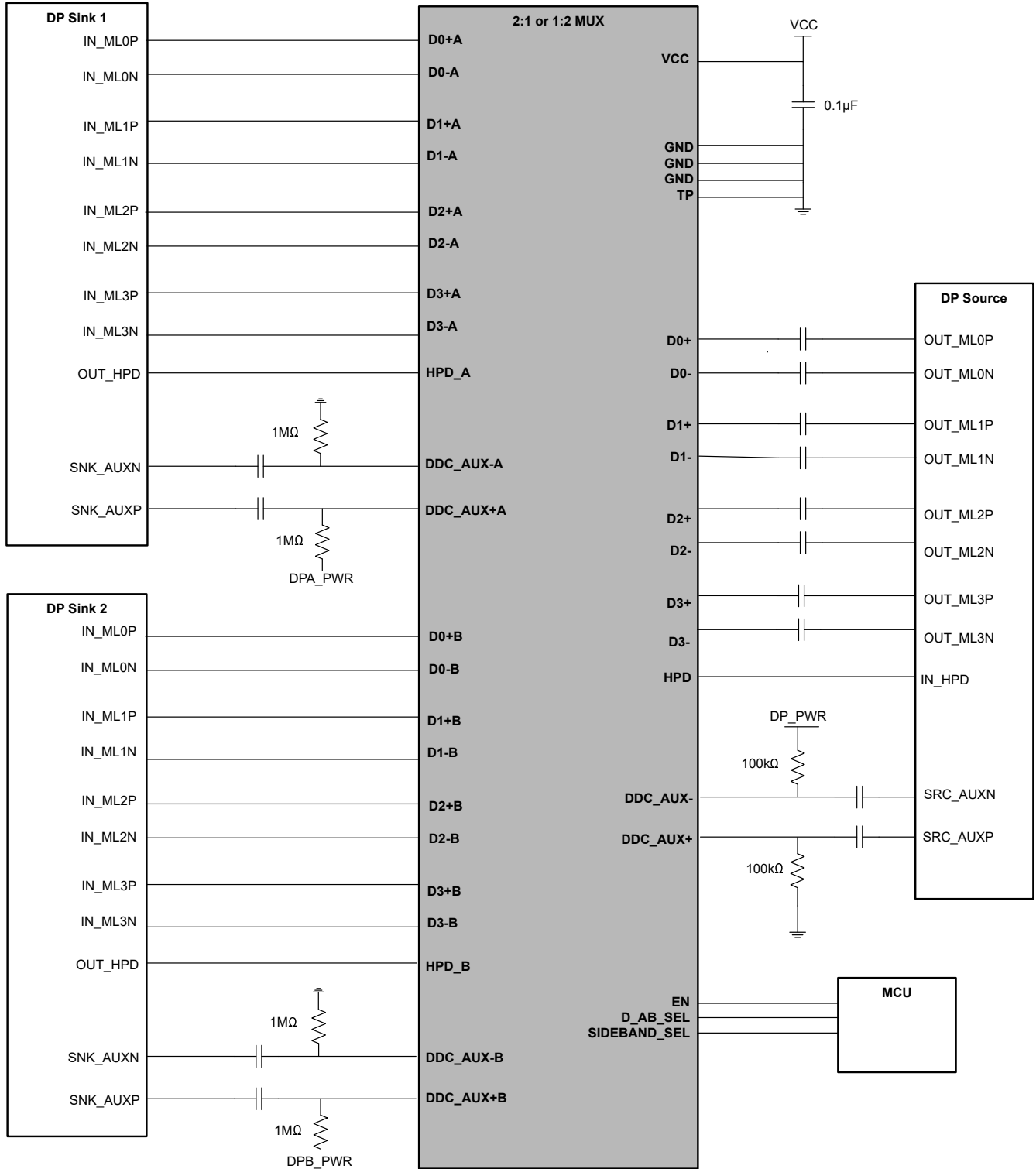

8-8. DisplayPort 1:2 Switching

9 Device and Documentation Support

9.1 Documentation Support

9.1.1 Related Documentation

For related documentation, see the following:

- Texas Instruments, [Implications of Slow or Floating CMOS Inputs application note](#).

9.2 ドキュメントの更新通知を受け取る方法

ドキュメントの更新についての通知を受け取るには、www.tij.co.jp のデバイス製品フォルダを開いてください。[通知] をクリックして登録すると、変更されたすべての製品情報に関するダイジェストを毎週受け取ることができます。変更の詳細については、改訂されたドキュメントに含まれている改訂履歴をご覧ください。

9.3 サポート・リソース

テキサス・インスツルメンツ E2E™ サポート・フォーラムは、エンジニアが検証済みの回答と設計に関するヒントをエキスパートから迅速かつ直接得ることができる場所です。既存の回答を検索したり、独自の質問をしたりすることで、設計に必要な支援を迅速に得ることができます。

リンクされているコンテンツは、各寄稿者により「現状のまま」提供されるものです。これらはテキサス・インスツルメンツの仕様を構成するものではなく、必ずしもテキサス・インスツルメンツの見解を反映したものではありません。テキサス・インスツルメンツの[使用条件](#)を参照してください。

9.4 Trademarks

テキサス・インスツルメンツ E2E™ is a trademark of Texas Instruments.

すべての商標は、それぞれの所有者に帰属します。

9.5 静電気放電に関する注意事項



この IC は、ESD によって破損する可能性があります。テキサス・インスツルメンツは、IC を取り扱う際には常に適切な注意を払うことを推奨します。正しい取り扱いおよび設置手順に従わない場合、デバイスを破損するおそれがあります。

ESD による破損は、わずかな性能低下からデバイスの完全な故障まで多岐にわたります。精密な IC の場合、パラメータがわずかに変化するだけで公表されている仕様から外れる可能性があるため、破損が発生しやすくなっています。

9.6 用語集

[テキサス・インスツルメンツ用語集](#) この用語集には、用語や略語の一覧および定義が記載されています。

10 Revision History

資料番号末尾の英字は改訂を表しています。その改訂履歴は英語版に準じています。

Changes from Revision * (June 2024) to Revision A (November 2024)

Page

- | | |
|-------------------------------------|---|
| • データシートのステータスを「事前情報」から「量産データ」..... | 1 |
|-------------------------------------|---|

11 Mechanical, Packaging, and Orderable Information

The following pages include mechanical, packaging, and orderable information. This information is the most current data available for the designated devices. This data is subject to change without notice and revision of this document. For browser-based versions of this data sheet, refer to the left-hand navigation.

重要なお知らせと免責事項

テキサス・インスツルメンツは、技術データと信頼性データ (データシートを含みます)、設計リソース (リファレンス デザインを含みます)、アプリケーションや設計に関する各種アドバイス、Web ツール、安全性情報、その他のリソースを、欠陥が存在する可能性のある「現状のまま」提供しており、商品性および特定目的に対する適合性の黙示保証、第三者の知的財産権の非侵害保証を含むいかなる保証も、明示的または黙示的にかかわらず拒否します。

これらのリソースは、テキサス・インスツルメンツ製品を使用する設計の経験を積んだ開発者への提供を意図したものです。(1) お客様のアプリケーションに適した テキサス・インスツルメンツ製品の選定、(2) お客様のアプリケーションの設計、検証、試験、(3) お客様のアプリケーションに該当する各種規格や、その他のあらゆる安全性、セキュリティ、規制、または他の要件への確実な適合に関する責任を、お客様のみが単独で負うものとします。

上記の各種リソースは、予告なく変更される可能性があります。これらのリソースは、リソースで説明されている テキサス・インスツルメンツ製品を使用するアプリケーションの開発の目的でのみ、テキサス・インスツルメンツはその使用をお客様に許諾します。これらのリソースに関して、他の目的で複製することや掲載することは禁止されています。テキサス・インスツルメンツや第三者の知的財産権のライセンスが付与されている訳ではありません。お客様は、これらのリソースを自身で使用した結果発生するあらゆる申し立て、損害、費用、損失、責任について、テキサス・インスツルメンツおよびその代理人を完全に補償するものとし、テキサス・インスツルメンツは一切の責任を拒否します。

テキサス・インスツルメンツの製品は、[テキサス・インスツルメンツの販売条件](#)、または [ti.com](https://www.ti.com) やかかる テキサス・インスツルメンツ製品の関連資料などのいずれかを通じて提供する適用可能な条項の下で提供されています。テキサス・インスツルメンツがこれらのリソースを提供することは、適用されるテキサス・インスツルメンツの保証または他の保証の放棄の拡大や変更を意味するものではありません。

お客様がいかなる追加条項または代替条項を提案した場合でも、テキサス・インスツルメンツはそれらに異議を唱え、拒否します。

郵送先住所: Texas Instruments, Post Office Box 655303, Dallas, Texas 75265

Copyright © 2024, Texas Instruments Incorporated

PACKAGING INFORMATION

Orderable Device	Status (1)	Package Type	Package Drawing	Pins	Package Qty	Eco Plan (2)	Lead finish/ Ball material (6)	MSL Peak Temp (3)	Op Temp (°C)	Device Marking (4/5)	Samples
TMUXHS4612IRETR	ACTIVE	WQFN	RET	40	3000	RoHS & Green	NIPDAU	Level-2-260C-1 YEAR	-40 to 125	TMX412	Samples
TMUXHS4612IRETT	ACTIVE	WQFN	RET	40	250	RoHS & Green	NIPDAU	Level-2-260C-1 YEAR	-40 to 125	TMX412	Samples
TMUXHS4612RETR	ACTIVE	WQFN	RET	40	3000	RoHS & Green	NIPDAU	Level-2-260C-1 YEAR	0 to 105	TMX412	Samples
TMUXHS4612RETT	ACTIVE	WQFN	RET	40	250	RoHS & Green	NIPDAU	Level-2-260C-1 YEAR	0 to 105	TMX412	Samples

(1) The marketing status values are defined as follows:

ACTIVE: Product device recommended for new designs.

LIFEBUY: TI has announced that the device will be discontinued, and a lifetime-buy period is in effect.

NRND: Not recommended for new designs. Device is in production to support existing customers, but TI does not recommend using this part in a new design.

PREVIEW: Device has been announced but is not in production. Samples may or may not be available.

OBSELETE: TI has discontinued the production of the device.

(2) **RoHS:** TI defines "RoHS" to mean semiconductor products that are compliant with the current EU RoHS requirements for all 10 RoHS substances, including the requirement that RoHS substance do not exceed 0.1% by weight in homogeneous materials. Where designed to be soldered at high temperatures, "RoHS" products are suitable for use in specified lead-free processes. TI may reference these types of products as "Pb-Free".

RoHS Exempt: TI defines "RoHS Exempt" to mean products that contain lead but are compliant with EU RoHS pursuant to a specific EU RoHS exemption.

Green: TI defines "Green" to mean the content of Chlorine (Cl) and Bromine (Br) based flame retardants meet JS709B low halogen requirements of <=1000ppm threshold. Antimony trioxide based flame retardants must also meet the <=1000ppm threshold requirement.

(3) MSL, Peak Temp. - The Moisture Sensitivity Level rating according to the JEDEC industry standard classifications, and peak solder temperature.

(4) There may be additional marking, which relates to the logo, the lot trace code information, or the environmental category on the device.

(5) Multiple Device Markings will be inside parentheses. Only one Device Marking contained in parentheses and separated by a "-" will appear on a device. If a line is indented then it is a continuation of the previous line and the two combined represent the entire Device Marking for that device.

(6) Lead finish/Ball material - Orderable Devices may have multiple material finish options. Finish options are separated by a vertical ruled line. Lead finish/Ball material values may wrap to two lines if the finish value exceeds the maximum column width.

Important Information and Disclaimer:The information provided on this page represents TI's knowledge and belief as of the date that it is provided. TI bases its knowledge and belief on information provided by third parties, and makes no representation or warranty as to the accuracy of such information. Efforts are underway to better integrate information from third parties. TI has taken and

continues to take reasonable steps to provide representative and accurate information but may not have conducted destructive testing or chemical analysis on incoming materials and chemicals. TI and TI suppliers consider certain information to be proprietary, and thus CAS numbers and other limited information may not be available for release.

In no event shall TI's liability arising out of such information exceed the total purchase price of the TI part(s) at issue in this document sold by TI to Customer on an annual basis.

TAPE AND REEL INFORMATION

QUADRANT ASSIGNMENTS FOR PIN 1 ORIENTATION IN TAPE

*All dimensions are nominal

Device	Package Type	Package Drawing	Pins	SPQ	Reel Diameter (mm)	Reel Width W1 (mm)	A0 (mm)	B0 (mm)	K0 (mm)	P1 (mm)	W (mm)	Pin1 Quadrant
TMUXHS4612IRETR	WQFN	RET	40	3000	330.0	12.4	3.3	6.3	1.05	8.0	12.0	Q1
TMUXHS4612IRETT	WQFN	RET	40	250	180.0	12.4	3.3	6.3	1.05	8.0	12.0	Q1
TMUXHS4612RETR	WQFN	RET	40	3000	330.0	12.4	3.3	6.3	1.05	8.0	12.0	Q1
TMUXHS4612RETT	WQFN	RET	40	250	180.0	12.4	3.3	6.3	1.05	8.0	12.0	Q1

TAPE AND REEL BOX DIMENSIONS



*All dimensions are nominal

Device	Package Type	Package Drawing	Pins	SPQ	Length (mm)	Width (mm)	Height (mm)
TMUXHS4612IRETR	WQFN	RET	40	3000	367.0	367.0	38.0
TMUXHS4612IRETT	WQFN	RET	40	250	213.0	191.0	35.0
TMUXHS4612RETR	WQFN	RET	40	3000	367.0	367.0	38.0
TMUXHS4612RETT	WQFN	RET	40	250	213.0	191.0	35.0

RET0040A



PACKAGE OUTLINE

WQFN - 0.8 mm max height

PLASTIC QUAD FLATPACK - NO LEAD

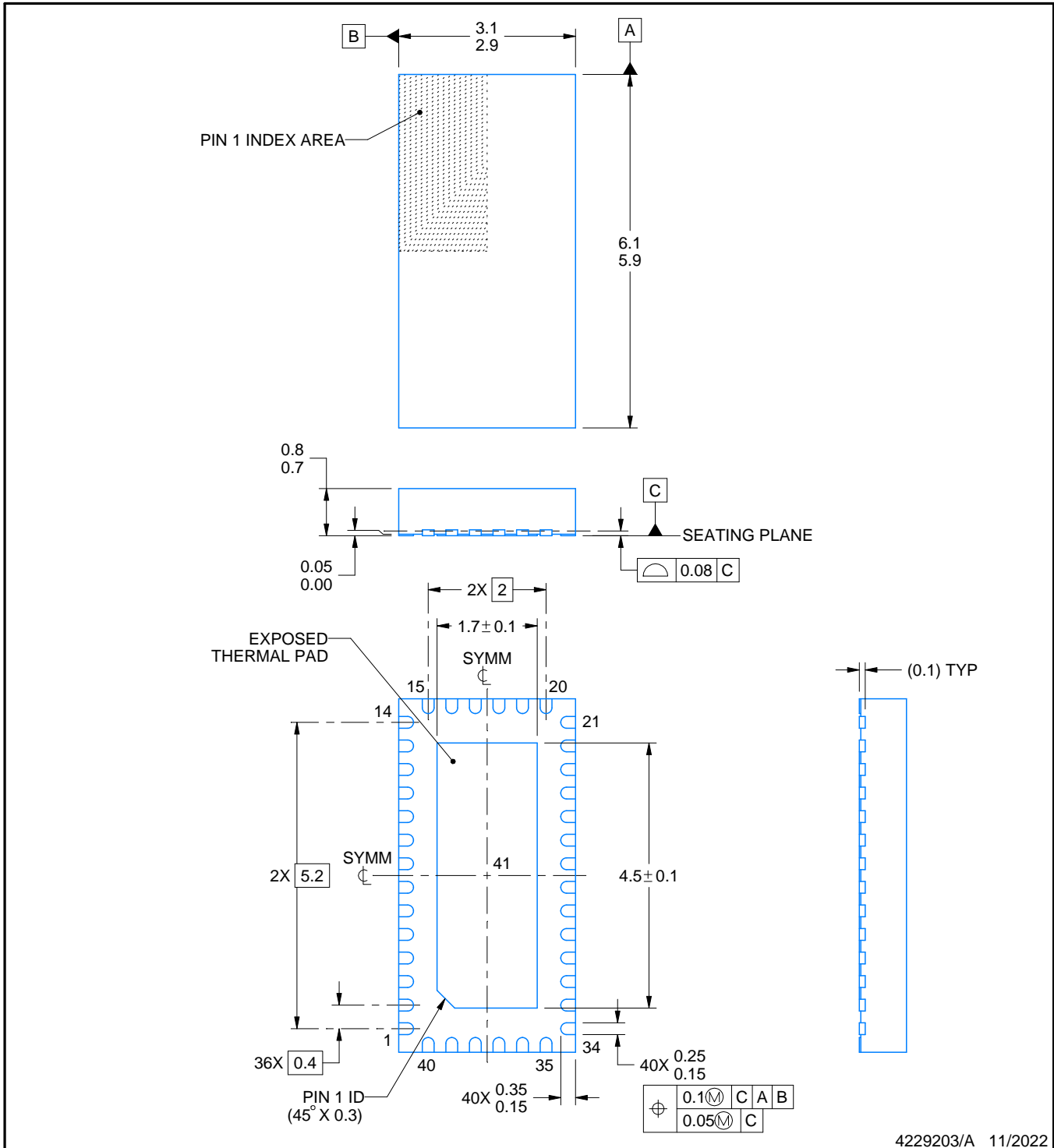

4229203/A 11/2022

NOTES:

1. All linear dimensions are in millimeters. Any dimensions in parenthesis are for reference only. Dimensioning and tolerancing per ASME Y14.5M.
2. This drawing is subject to change without notice.
3. The package thermal pad must be soldered to the printed circuit board for thermal and mechanical performance.

EXAMPLE BOARD LAYOUT

RET0040A

WQFN - 0.8 mm max height

PLASTIC QUAD FLATPACK - NO LEAD

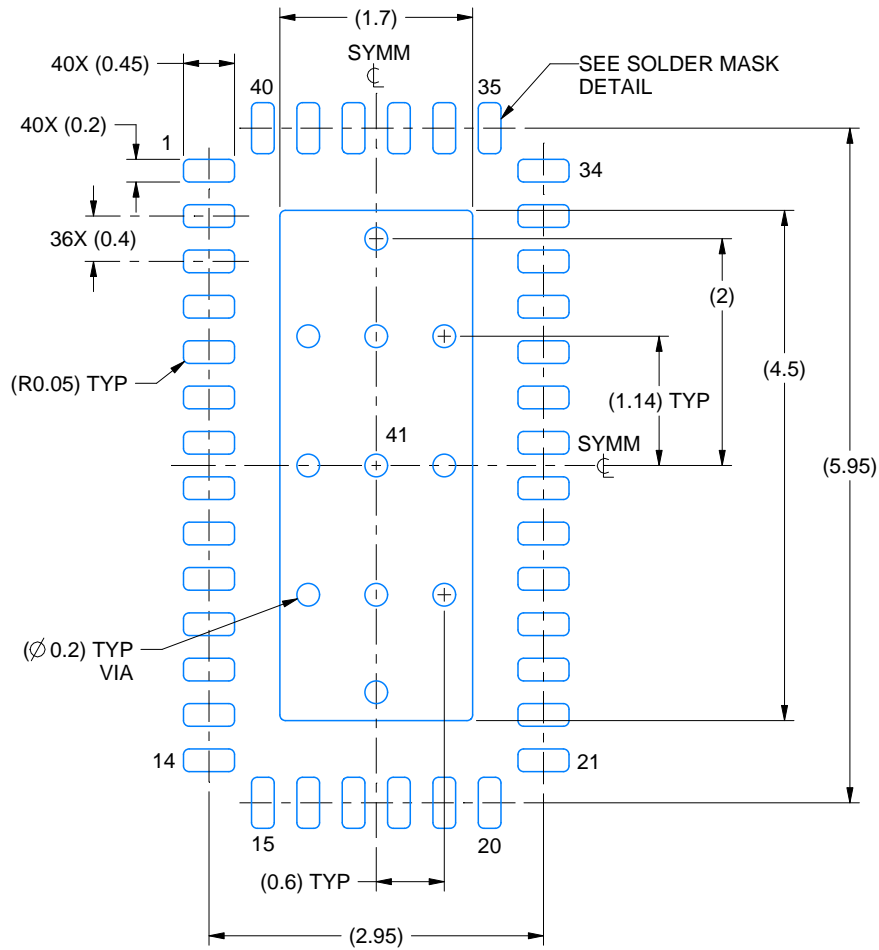

LAND PATTERN EXAMPLE
EXPOSED METAL SHOWN
SCALE: 15X

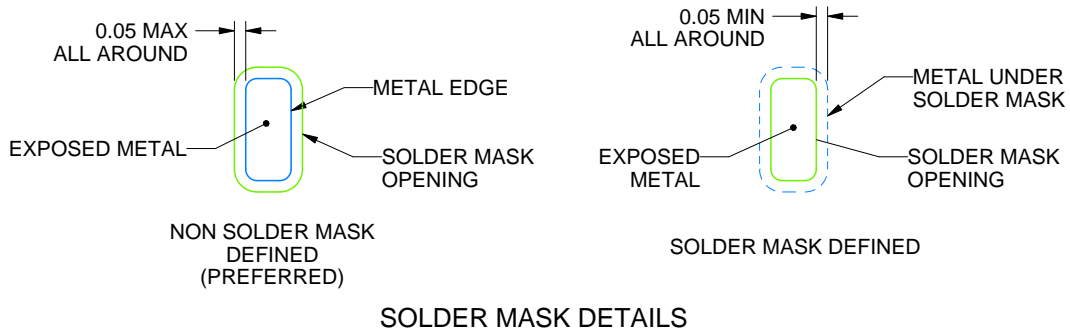

4229203/A 11/2022

NOTES: (continued)

4. This package is designed to be soldered to a thermal pad on the board. For more information, see Texas Instruments literature number SLUA271 (www.ti.com/lit/slua271).
5. Vias are optional depending on application, refer to device data sheet. If any vias are implemented, refer to their locations shown on this view. It is recommended that vias under paste be filled, plugged or tented.

EXAMPLE STENCIL DESIGN

RET0040A

WQFN - 0.8 mm max height

PLASTIC QUAD FLATPACK - NO LEAD

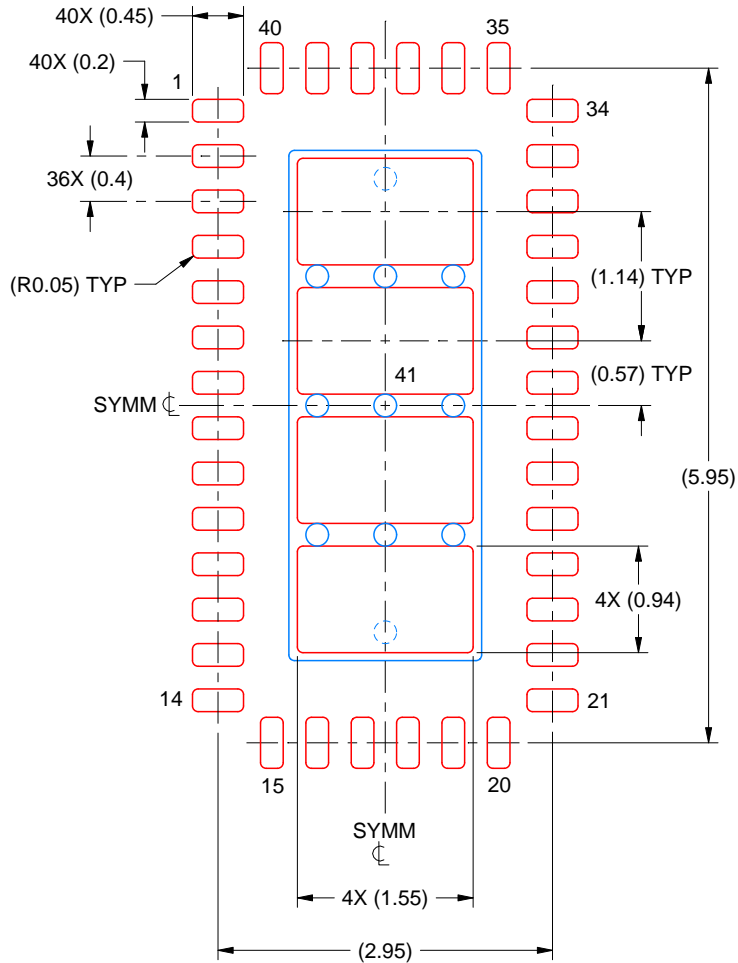

SOLDER PASTE EXAMPLE
BASED ON 0.125 MM THICK STENCIL
SCALE: 15X

EXPOSED PAD 41
76% PRINTED SOLDER COVERAGE BY AREA UNDER PACKAGE

4229203/A 11/2022

NOTES: (continued)

6. Laser cutting apertures with trapezoidal walls and rounded corners may offer better paste release. IPC-7525 may have alternate design recommendations.

重要なお知らせと免責事項

TI は、技術データと信頼性データ(データシートを含みます)、設計リソース(リファレンス・デザインを含みます)、アプリケーションや設計に関する各種アドバイス、Web ツール、安全性情報、その他のリソースを、欠陥が存在する可能性のある「現状のまま」提供しており、商品性および特定目的に対する適合性の黙示保証、第三者の知的財産権の非侵害保証を含むいかなる保証も、明示的または黙示的にかかわらず拒否します。

これらのリソースは、TI 製品を使用する設計の経験を積んだ開発者への提供を意図したものです。(1) お客様のアプリケーションに適した TI 製品の選定、(2) お客様のアプリケーションの設計、検証、試験、(3) お客様のアプリケーションに該当する各種規格や、その他のあらゆる安全性、セキュリティ、規制、または他の要件への確実な適合に関する責任を、お客様のみが単独で負うものとし、

上記の各種リソースは、予告なく変更される可能性があります。これらのリソースは、リソースで説明されている TI 製品を使用するアプリケーションの開発の目的でのみ、TI はその使用をお客様に許諾します。これらのリソースに関して、他の目的で複製することや掲載することは禁止されています。TI や第三者の知的財産権のライセンスが付与されている訳ではありません。お客様は、これらのリソースを自身で使用した結果発生するあらゆる申し立て、損害、費用、損失、責任について、TI およびその代理人を完全に補償するものとし、TI は一切の責任を拒否します。

TI の製品は、[TI の販売条件](#)、または [ti.com](#) やかかる TI 製品の関連資料などのいずれかを通じて提供する適用可能な条項の下で提供されています。TI がこれらのリソースを提供することは、適用される TI の保証または他の保証の放棄の拡大や変更を意味するものではありません。

お客様がいかなる追加条項または代替条項を提案した場合でも、TI はそれらに異議を唱え、拒否します。

郵送先住所 : Texas Instruments, Post Office Box 655303, Dallas, Texas 75265
Copyright © 2024, Texas Instruments Incorporated