

# TLV1805 40V、レール・ツー・レール入力、プッシュプル出力、シャットダウン機能付きの高電圧コンパレータ

## 1 特長

- 電源電圧範囲：3.3V～40V
- 低い静止電流：135 $\mu$ A
- ピーク電流の大きいプッシュプル出力
- 位相反転保護機能付きのレール・ツー・レール入力
- 内蔵ヒステリシス：14mV
- 伝搬遅延時間：250ns
- 低い入力オフセット電圧：500 $\mu$ V
- ハイ・インピーダンス出力のシャットダウン
- パワーオン・リセット (POR)
- SOT-23-6 パッケージ

## 2 アプリケーション

- 逆電流保護のスマート・ダイオード・コントローラ
- 過電圧、低電圧、過電流の検出
- OR 接続 MOSFET コントローラ
- MOSFET ゲート・ドライバ
- 高電圧発振器
- システム監視
  - インフォテインメントおよびクラスタ
  - PLC
  - サーバー
  - モータ保護および制御

### P チャンネル MOSFET による過電圧保護

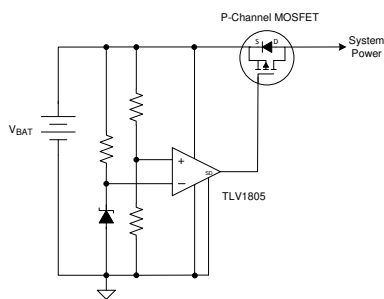

## 3 概要

TLV1805 高電圧コンパレータは、広い電源電圧範囲、プッシュプル出力、レール・ツー・レール入力、小さい静止電流、シャットダウン機能、高速な出力応答を持ち合わせた独自の製品です。これらすべての特長から、このコンパレータはスマート・ダイオード・コントローラの逆電流保護、過電流検出、およびプッシュプル出力段を使用して P チャンネルまたは N チャンネル MOSFET スイッチのゲートを駆動する過電圧保護回路など、正または負の電圧レールでの検出を必要とするアプリケーションに適しています。

### 製品情報<sup>(1)</sup>

型番	パッケージ	本体サイズ(公称)
TLV1805	SOT-23 (6)	1.60mmx2.90mm

(1) 利用可能なすべてのパッケージについては、このデータシートの末尾にあるパッケージ・オプションについての付録を参照してください。

### P チャンネル MOSFET による逆電流および過電圧保護

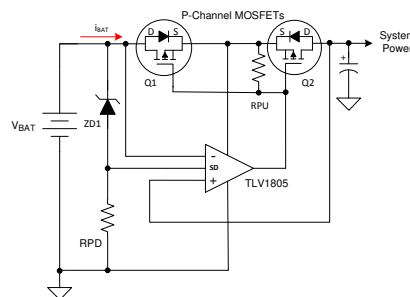

## 目次

1	特長 .....	1	8.3	Feature Description .....	17
2	アプリケーション .....	1	8.4	Device Functional Modes .....	18
3	概要 .....	1	<b>9</b>	<b>Application and Implementation .....</b>	<b>21</b>
4	改訂履歴 .....	2	9.1	Application Information .....	21
5	概要 (続き) .....	2	9.2	Typical Applications .....	21
6	<b>Pin Configuration and Functions .....</b>	<b>3</b>	<b>10</b>	<b>Power Supply Recommendations .....</b>	<b>28</b>
7	<b>Specifications .....</b>	<b>4</b>	<b>11</b>	<b>Layout .....</b>	<b>28</b>
7.1	Absolute Maximum Ratings .....	4	11.1	Layout Guidelines .....	28
7.2	ESD Ratings .....	4	11.2	Layout Example .....	28
7.3	Recommended Operating Conditions .....	4	<b>12</b>	<b>デバイスおよびドキュメントのサポート .....</b>	<b>29</b>
7.4	Thermal Information .....	4	12.1	ドキュメントのサポート .....	29
7.5	Electrical Characteristics .....	5		ドキュメントの更新通知を受け取る方法 .....	29
7.6	Switching Characteristics .....	5	12.3	コミュニティ・リソース .....	29
7.7	Typical Characteristics .....	7	12.4	商標 .....	29
<b>8</b>	<b>Detailed Description .....</b>	<b>17</b>	12.5	静電気放電に関する注意事項 .....	29
8.1	Overview .....	17	12.6	Glossary .....	29
8.2	Functional Block Diagram .....	17	<b>13</b>	<b>メカニカル、パッケージ、および注文情報 .....</b>	<b>29</b>

## 4 改訂履歴

資料番号末尾の英字は改訂を表しています。その改訂履歴は英語版に準じています。

日付	リビジョン	注
2018年12月	*	初版 APL リリース。

## 5 概要 (続き)

高電圧コンパレータとしては珍しく、ピーク電流の大きいプッシュプル出力段には、どちらの電源レールへの負荷も高いエッジ速度でアクティブに駆動できるという利点があります。これは、予期しない高電圧電源へのホストの接続/切断を制御するために、MOSFET ゲートを迅速に HIGH または LOW に駆動する必要があるアプリケーションでは特に重要です。その他にも、低い入力オフセット電圧、低い入力バイアス電流、High-Z のシャットダウンなどの特長を備えているため、TLV1805 は広範なアプリケーションを柔軟に処理できます。パワー・オン・リセットにより、電源オン時の誤出力が防止されます。

TLV1805 は 6 ピン SOT-23 パッケージで、拡張産業用温度範囲の  $-40^{\circ}\text{C}$  ~  $+125^{\circ}\text{C}$  で動作が規定されています。

## 6 Pin Configuration and Functions

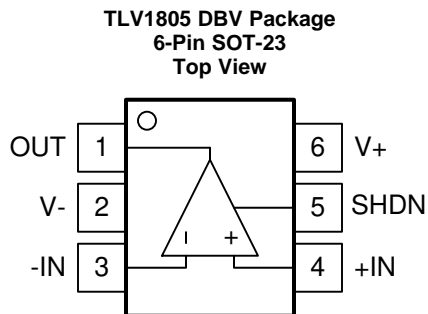

Note the reversed positions of the input pins. This differs from a similar popular pinout.

### Pin Functions

PIN		TYPE	DESCRIPTION
NAME	NO.		
IN+	4	I	Noninverting input
IN-	3	I	Inverting input
OUT	1	O	Output
SHDN	5	I	Shutdown (active high)
V+	6	P	Positive (highest) power supply
V-	2	P	Negative (lowest) power supply

## 7 Specifications

### 7.1 Absolute Maximum Ratings

over operating free-air temperature range (unless otherwise noted)<sup>(1)</sup>

	MIN	MAX	UNIT
Supply voltage: $V_S = (V+) - (V-)$	-0.3	42	V
Input pins (IN+, IN-) <sup>(2)</sup>	(V-) - 0.3	(V+) + 0.3	V
Shutdown pin (SHDN) <sup>(3)</sup>	(V-) - 0.3	(V-) + 5.5	V
Current into Input pins (IN+, IN-, SHDN) <sup>(2)</sup>		±10	mA
Output (OUT)	(V-) - 0.3	(V+) + 0.3	V
Operating temperature	-55	150	°C
Junction temperature, $T_J$		150	°C
Storage temperature, $T_{stg}$	-65	150	°C

- Stresses beyond those listed under *Absolute Maximum Ratings* may cause permanent damage to the device. These are stress ratings only, which do not imply functional operation of the device at these or any other conditions beyond those indicated under *Recommended Operating Conditions*. Exposure to absolute-maximum-rated conditions for extended periods may affect device reliability.
- Input terminals are diode-clamped to the power-supply rails. Input signals that can swing more than 0.3 V beyond the supply rails must be current-limited to 10 mA or less.
- Shutdown pin is diode-clamped to (V-). Input to SHDN that can swing more than 0.3 V below (V-) must be current-limited to 10 mA or less.

### 7.2 ESD Ratings

			VALUE	UNIT
$V_{(ESD)}$	Electrostatic discharge	Human-body model (HBM), per ANSI/ESDA/JEDEC JS-001 <sup>(1)</sup>	±1500	V
		Charged-device model (CDM), per JEDEC specification JESD22-C101 <sup>(2)</sup>	±750	

- JEDEC document JEP155 states that 500-V HBM allows safe manufacturing with a standard ESD control process.
- JEDEC document JEP157 states that 250-V CDM allows safe manufacturing with a standard ESD control process.

### 7.3 Recommended Operating Conditions

over operating free-air temperature range (unless otherwise noted)

	MIN	MAX	UNIT
Supply voltage: $V_S = (V+) - (V-)$	3.3	40	V
Ambient temperature, $T_A$	-40	125	°C

### 7.4 Thermal Information

THERMAL METRIC <sup>(1)</sup>		TLV1805	UNIT
		DBV (SOT23)	
		6 PINS	
$R_{\theta JA}$	Junction-to-ambient thermal resistance	166.9	°C/W
$R_{\theta JC(top)}$	Junction-to-case (top) thermal resistance	104.2	°C/W
$R_{\theta JB}$	Junction-to-board thermal resistance	46.8	°C/W
$\Psi_{JT}$	Junction-to-top characterization parameter	31.3	°C/W
$\Psi_{JB}$	Junction-to-board characterization parameter	46.6	°C/W

- For more information about traditional and new thermal metrics, see the [Semiconductor and IC Package Thermal Metrics](#) application report.

## 7.5 Electrical Characteristics

$V_S = 3.3\text{ V to }40\text{ V}$ ,  $V_{CM} = V_S / 2$ ;  $T_A = 25^\circ\text{C}$  (unless otherwise noted). Typical values are at  $V_S = 12\text{ V}$  and  $T_A = 25^\circ\text{C}$ ,  $V_{CM} = V_S / 2$

PARAMETER		TEST CONDITIONS	MIN	TYP	MAX	UNIT
V <sub>IO</sub>	Input offset voltage	$V_S = 3.3\text{V}, 12\text{V and }40\text{V}$	-4.5	±0.5	4.5	mV
		$V_S = 3.3\text{V}, 12\text{V and }40\text{V}, T_A = -40^\circ\text{C to }+125^\circ\text{C}$	-6.5		6.5	
dV <sub>IO</sub> /dT	Input offset voltage drift	$T_A = -40^\circ\text{C to }+125^\circ\text{C}$		±2.5		µV/°C
V <sub>HYS</sub>	Input hysteresis voltage			14		mV
V <sub>CM</sub>	Common-mode voltage range	$T_A = -40^\circ\text{C to }+125^\circ\text{C}$	(V-) - 0.2		(V+) + 0.2	V
I <sub>B</sub>	Input bias current			0.05		pA
I <sub>OS</sub>	Input offset current			0.05		pA
PSRR	Power-supply rejection ratio	$V_{CM} = V_-$		95		dB
CMRR	Common-mode rejection ratio	$(V_-) < V_{CM} < (V_+)$		80		dB
V <sub>OL</sub>	Voltage output swing from (V-)	$I_{SINK} \leq 5\text{mA}$ , input overdrive = -100 mV, $V_S = 5\text{V}, T_A = -40^\circ\text{C to }+125^\circ\text{C}$			300	mV
V <sub>OH</sub>	Voltage output swing from (V+)	$I_{SOURCE} \leq 5\text{mA}$ , input overdrive = +100 mV, $V_S = 5\text{V}, T_A = -40^\circ\text{C to }+125^\circ\text{C}$			300	mV
I <sub>sc_source</sub>	Peak charging current (sourcing) with output shorted to V- <sup>(1)</sup>	$V_S = 5\text{ V to }40\text{ V}$		100		mA
I <sub>sc_sink</sub>	Peak dis-charging current (sinking) with output shorted to V+ <sup>(1)</sup>	$V_S = 5\text{ V to }40\text{ V}$		100		mA
I <sub>Q</sub>	Quiescent current	$V_S = 12\text{ V}$ , no load, $V_{ID} = -0.1\text{ V}$ (output low), $T_A = 25^\circ\text{C}$		135	200	µA
		$V_S = 12\text{V to }40\text{V}$ no load, $V_{ID} = -0.1\text{ V}$ (output low), $T_A = -40^\circ\text{C to }+125^\circ\text{C}$			400	µA
t <sub>OFF</sub>	Time to enter shutdown	$C_L = 15\text{ pF}$		1.0		µs
t <sub>ON</sub>	Time to exit shutdown	$C_L = 15\text{ pF}$		2.3		µs
V <sub>SD</sub>	Shutdown input: voltage range <sup>(2)</sup>	$V_S = 3.3\text{ to }40\text{V}, T_A = -40\text{ to }125^\circ\text{C}$	0		5.5	V
V <sub>SD_VIH</sub>	SHDN pin input high level	$V_S = 3.3\text{ V and }40\text{V}, T_A = -40\text{ to }125^\circ\text{C}$	2	1.35		V
V <sub>SD_VIL</sub>	SHDN pin input low level	$V_S = 3.3\text{ V and }40\text{V}, T_A = -40\text{ to }125^\circ\text{C}$		0.65	0.4	V
I <sub>B-SDH</sub>	SHDN bias current	$V_S = V_{SD} = 5.5\text{ V}$		0.015		nA
		$V_S = 5\text{ V}, V_{SD} = 0\text{ V}$		0.001		nA
I <sub>Q-SD</sub>	Quiescent current (Shutdown)	$V_S = 12\text{V}; T_S = 25^\circ\text{C}; V_{SD} > V_{SD\_VIH\ Min}$		9.5	13	µA

(1) Continuous short circuit can result in excessive heating and exceeding the maximum allowed junction temperature of 150°C. Please refer to the Maximum Output Current Derating curve in the Typical Operation Plots.

(2) The recommended voltage range if V<sub>SD</sub> is independent of V<sub>S</sub>.

## 7.6 Switching Characteristics

Typical values are at  $T_A = 25^\circ\text{C}$ ,  $V_S = 12\text{ V}$ ,  $V_{CM} = V_S / 2$ ; Input overdrive = 100 mV (unless otherwise noted).

PARAMETER		TEST CONDITIONS	MIN	TYP	MAX	UNIT
t <sub>PHL</sub>	Propagation delay time, high-to-low <sup>(1)</sup>	$C_L = 15\text{ pF}$		250		ns
		$C_L = 4\text{ nF}$		450		ns
t <sub>PLH</sub>	Propagation delay time, low-to-high <sup>(1)</sup>	$C_L = 15\text{ pF}$		250		ns
		$C_L = 4\text{ nF}$		500		ns
t <sub>R</sub>	Rise time	20% to 80%, $C_L = 15\text{ pF}$		18		ns
		20% to 80%, $C_L = 4\text{ nF}$		0.3		µs
t <sub>F</sub>	Fall time	20% to 80%, $C_L = 15\text{ pF}$		10		ns
		20% to 80%, $C_L = 4\text{ nF}$		0.26		µs

(1) High-to-low and low-to-high refers to the transition at the input.

### Switching Characteristics (continued)

Typical values are at  $T_A = 25^\circ\text{C}$ ,  $V_S = 12\text{ V}$ ,  $V_{CM} = V_S / 2$ ; Input overdrive = 100 mV (unless otherwise noted).

PARAMETER	TEST CONDITIONS	MIN	TYP	MAX	UNIT
$t_{START}$	Power-up time <sup>(2)</sup>		45		$\mu\text{s}$

(2) During power on,  $V_S$  must exceed 3.3 V for  $t_{ON}$  before the output is in a correct state.



图 1. Propagation Delay



图 2. Shutdown Timing

### 7.7 Typical Characteristics

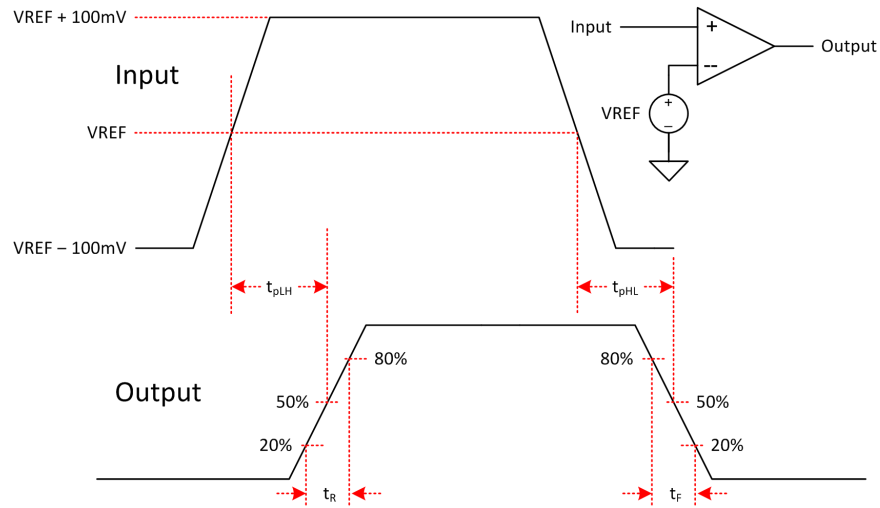
at  $T_A = 25^\circ\text{C}$ ,  $V_S = 12\text{ V}$ ,  $V_{CM} = V_S/2$ , and input overdrive = 100 mV (unless otherwise noted)

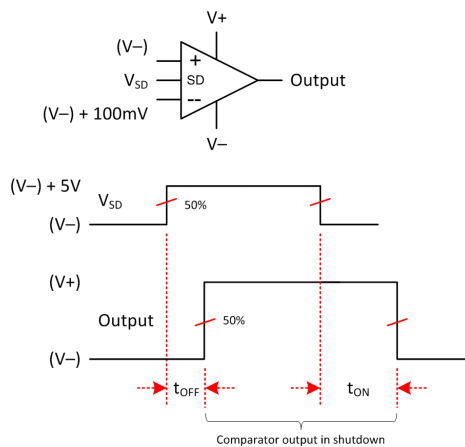
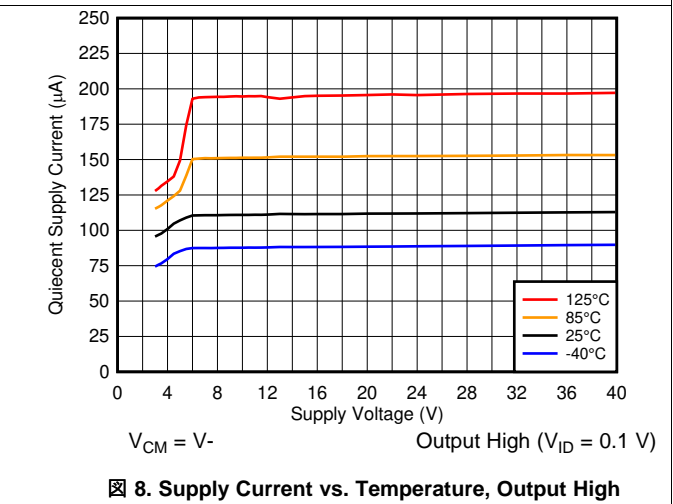
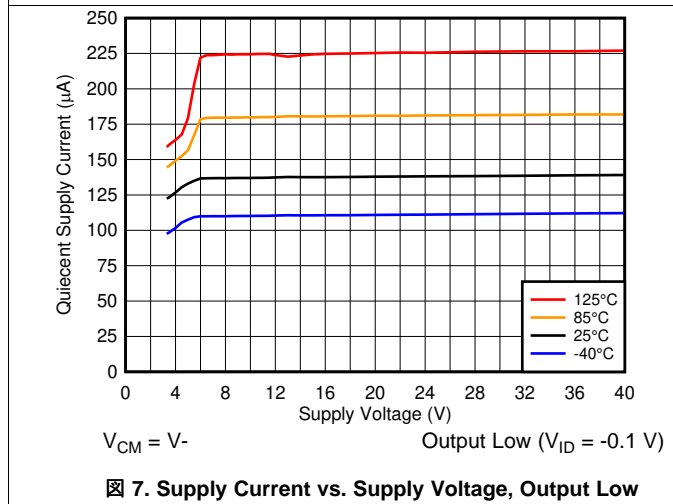
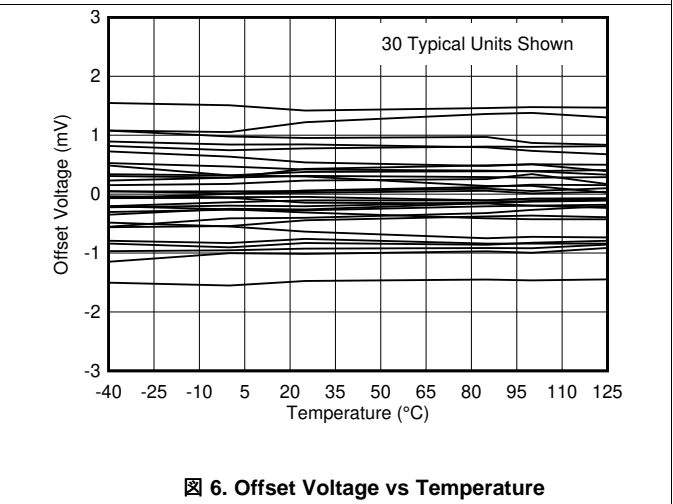
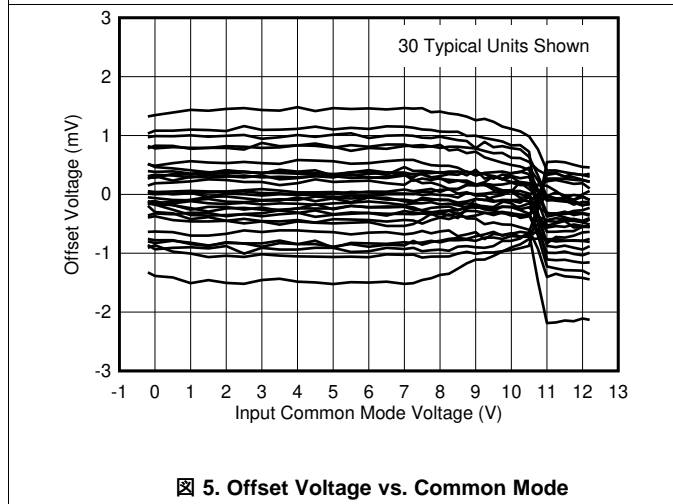
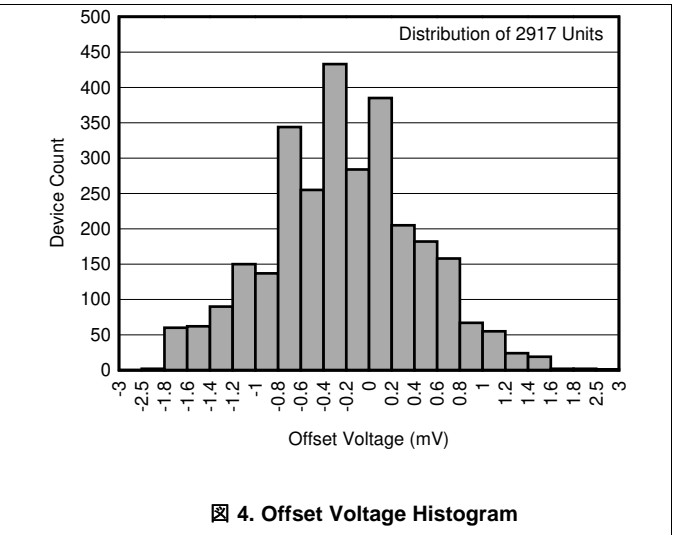
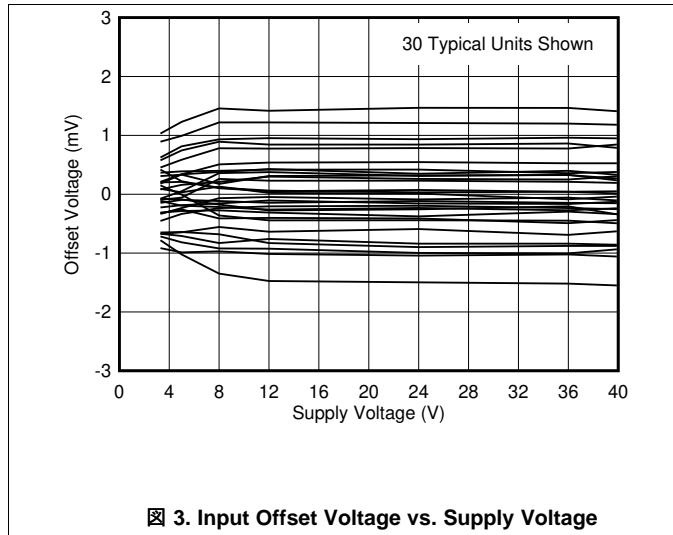

Typical Characteristics (continued)

at  $T_A = 25^\circ\text{C}$ ,  $V_S = 12\text{ V}$ ,  $V_{CM} = V_S/2$ , and input overdrive = 100 mV (unless otherwise noted)

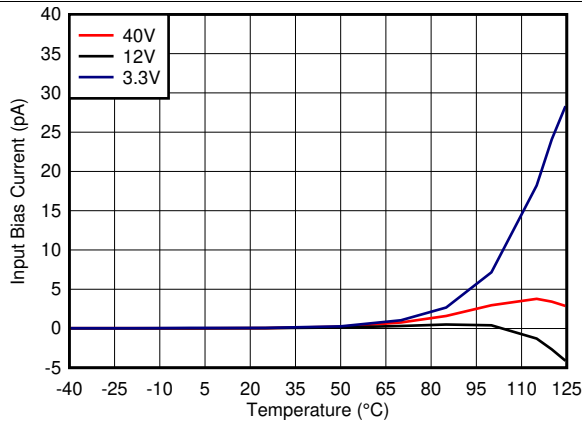

Fig 9. Input Bias Current vs. Temperature

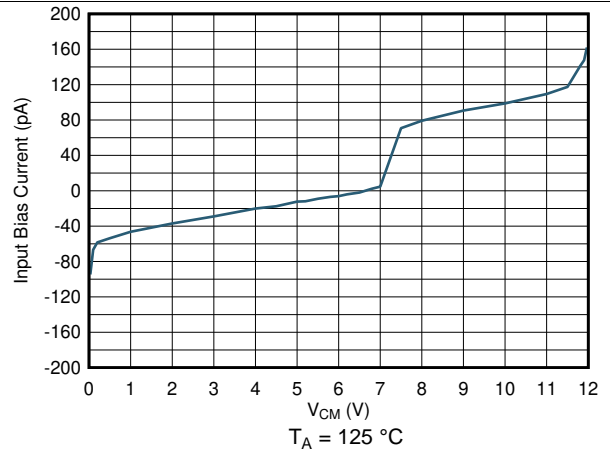

Fig 10. Input Bias Current vs. Common Mode, 125°C

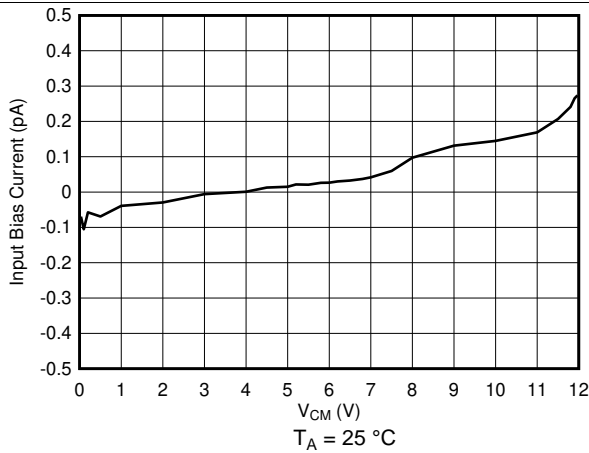

Fig 11. Input Bias Current vs. Common Mode, 25°C

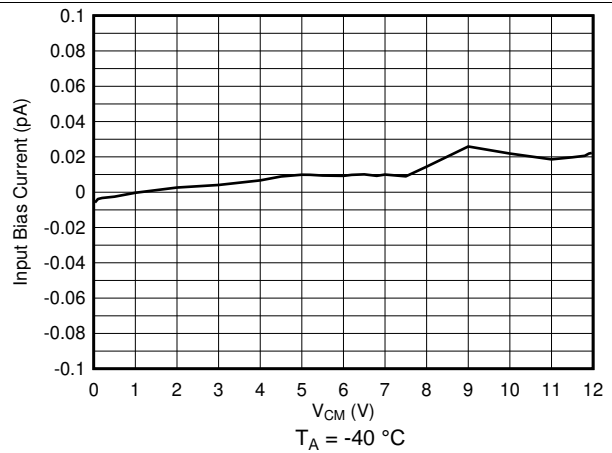

Fig 12. Input Bias Current vs. Common Mode, -40°C

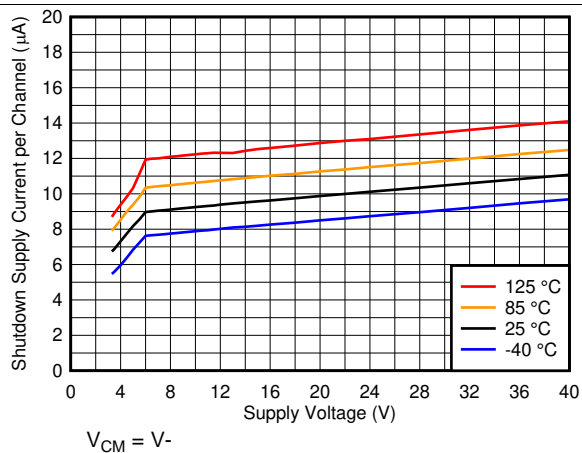

Fig 13. Shutdown Supply Current vs. Supply Voltage

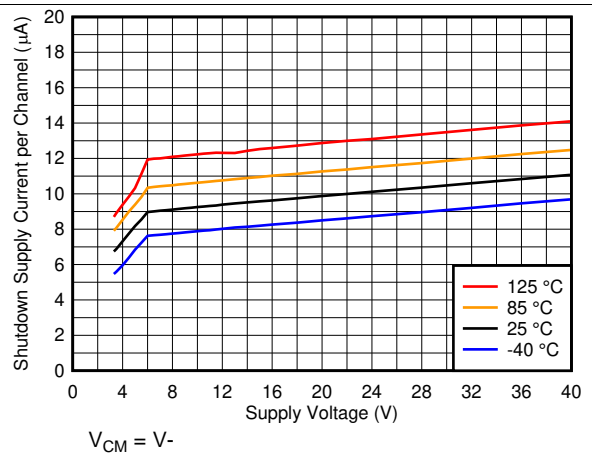
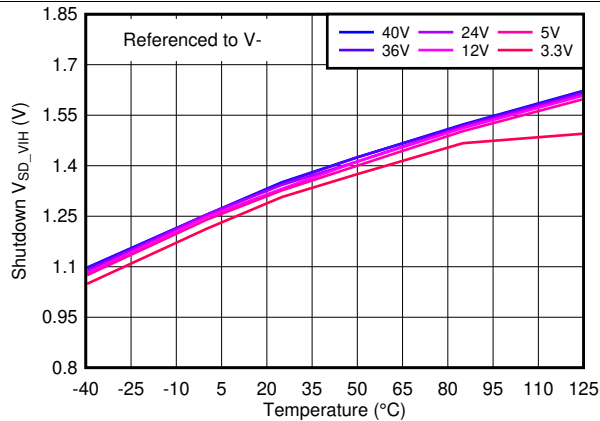

Fig 14. Shutdown Supply Current vs. Supply Voltage



Typical Characteristics (continued)

at  $T_A = 25^\circ\text{C}$ ,  $V_S = 12\text{ V}$ ,  $V_{CM} = V_S/2$ , and input overdrive = 100 mV (unless otherwise noted)



15. Shutdown Voltage High Threshold vs. Temperature

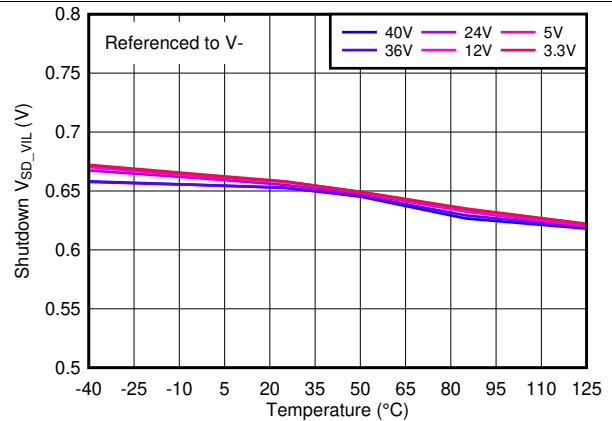

16. Shutdown Voltage Low Threshold vs. Temperature

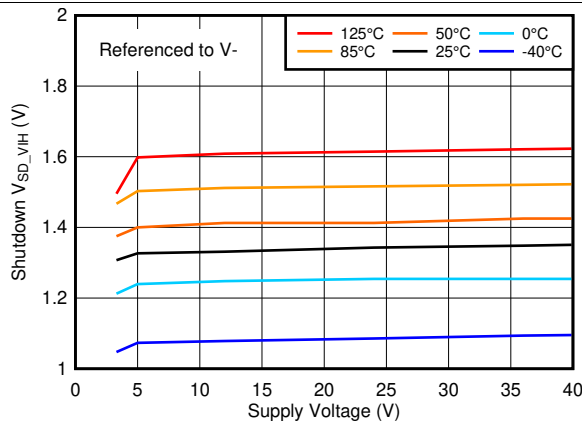

17. Shutdown Voltage High Threshold vs. Supply Voltage

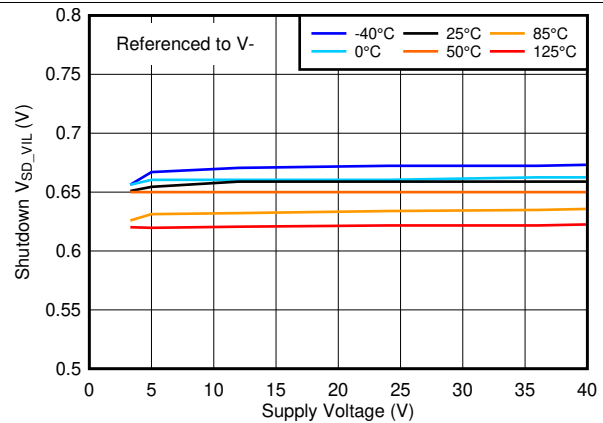

18. Shutdown Voltage Low Threshold vs. Supply Voltage

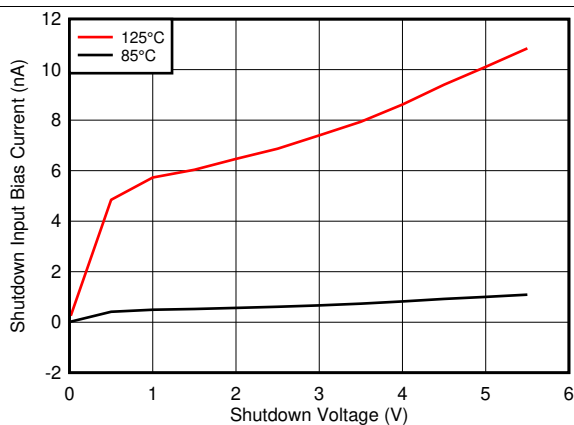

19. Shutdown Input Bias Current vs. Shutdown Input Voltage, High Temperatures

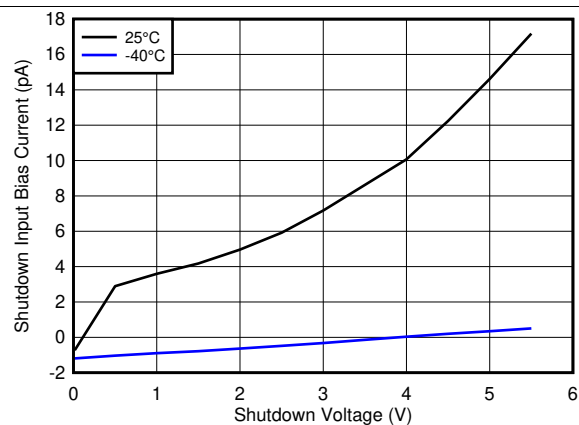

20. Shutdown Input Bias Current vs. Shutdown Input Voltage, Low Temperatures

**Typical Characteristics (continued)**

at  $T_A = 25^\circ\text{C}$ ,  $V_S = 12\text{ V}$ ,  $V_{CM} = V_S/2$ , and input overdrive = 100 mV (unless otherwise noted)

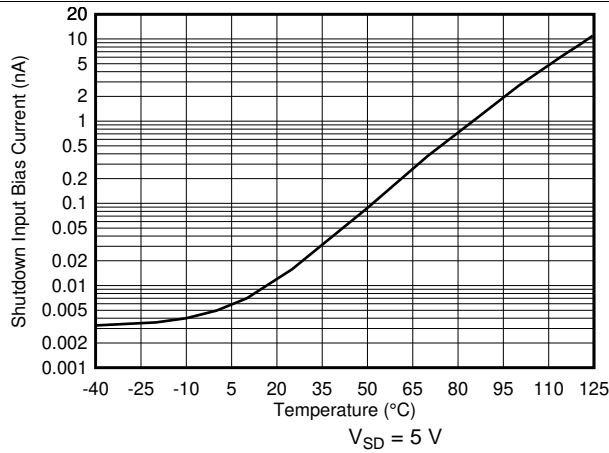

**21. Shutdown Input Bias Current vs. Temperature**

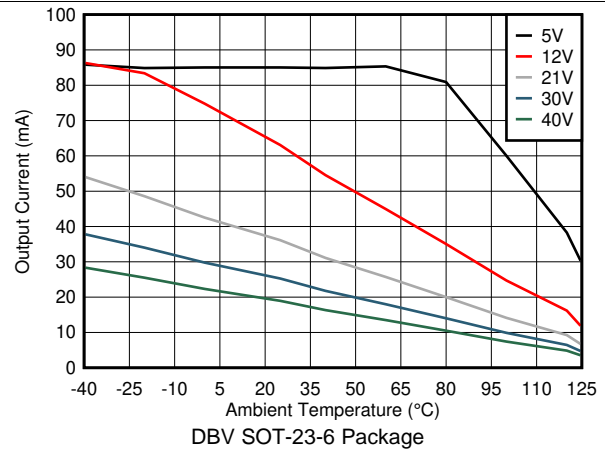

**22. Maximum Output Current vs. Ambient Temperature**  
DBV SOT-23-6 Package

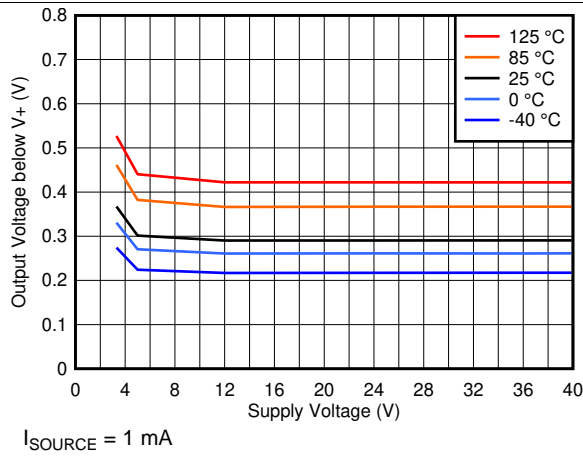

**23. Output High Voltage vs. Supply Voltage**  
 $I_{SOURCE} = 1\text{ mA}$

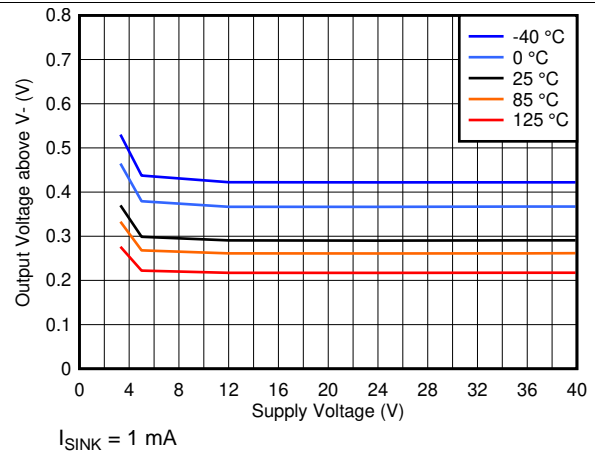

**24. Output Low Voltage vs. Supply Voltage**  
 $I_{SINK} = 1\text{ mA}$

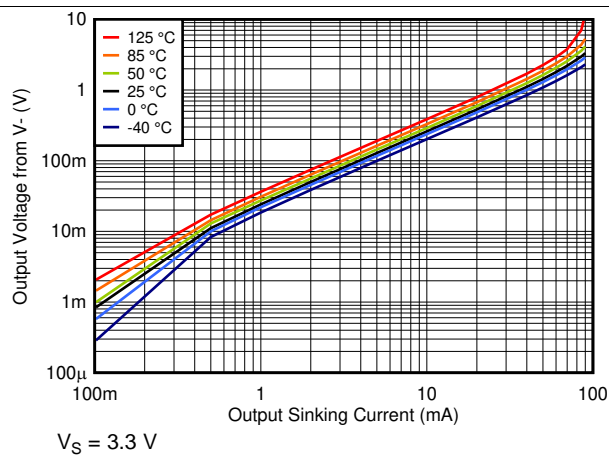

**25. Output Sinking Current vs. Output Voltage at 3.3V**  
 $V_S = 3.3\text{ V}$

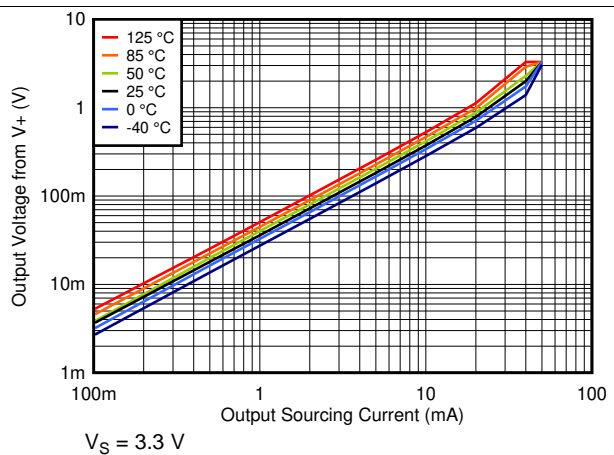

**26. Output Sourcing Current vs. Output Voltage at 3.3V**  
 $V_S = 3.3\text{ V}$

Typical Characteristics (continued)

at  $T_A = 25^\circ\text{C}$ ,  $V_S = 12\text{ V}$ ,  $V_{CM} = V_S/2$ , and input overdrive = 100 mV (unless otherwise noted)

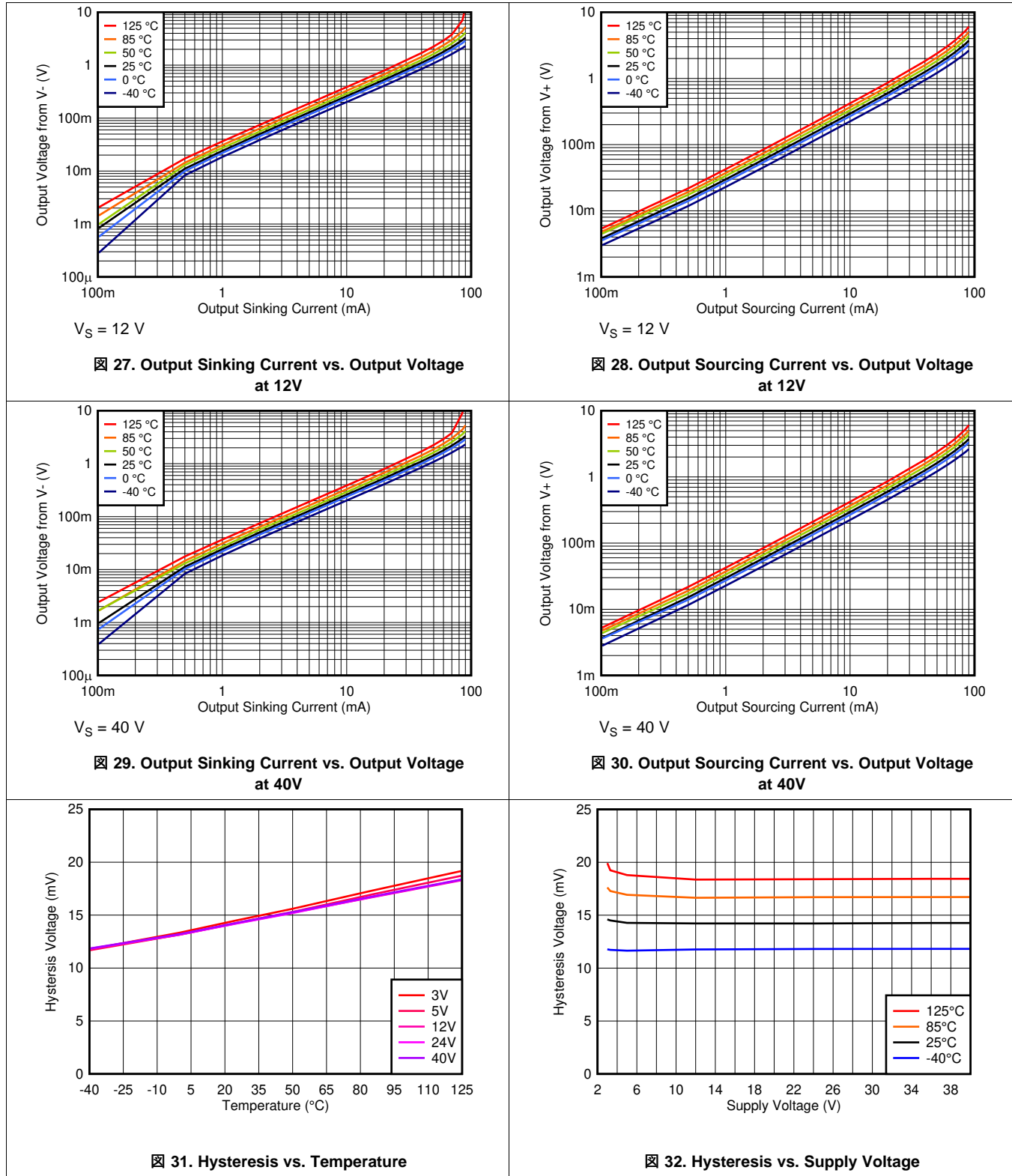

### Typical Characteristics (continued)

at  $T_A = 25^\circ\text{C}$ ,  $V_S = 12\text{ V}$ ,  $V_{CM} = V_S/2$ , and input overdrive = 100 mV (unless otherwise noted)

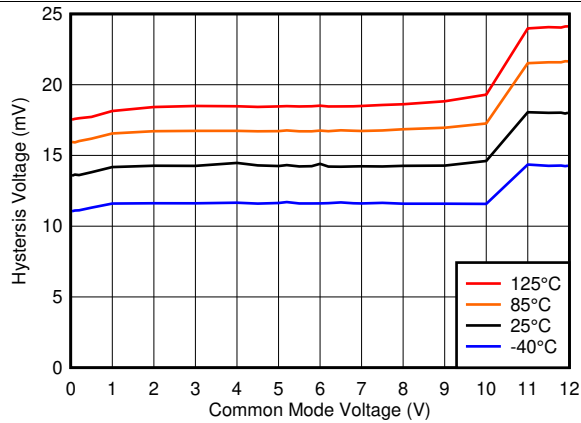

Figure 33. Hysteresis vs Common-Mode Voltage

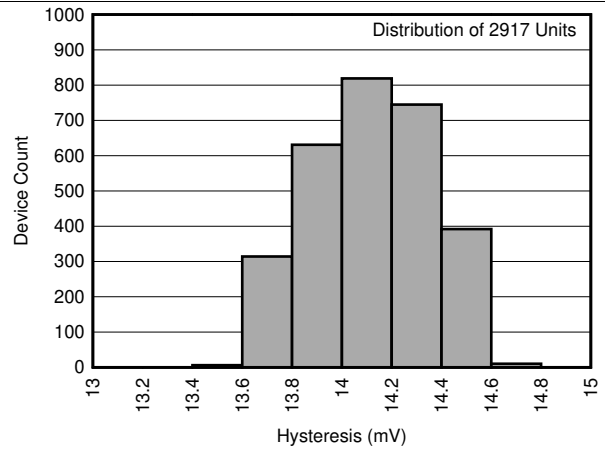

Figure 34. Hysteresis Histogram

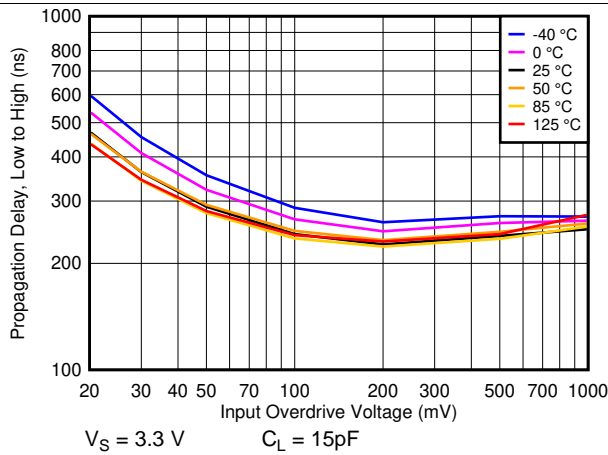

Figure 35.  $T_{PLH}$  Response Time vs. Overdrive at 3.3V

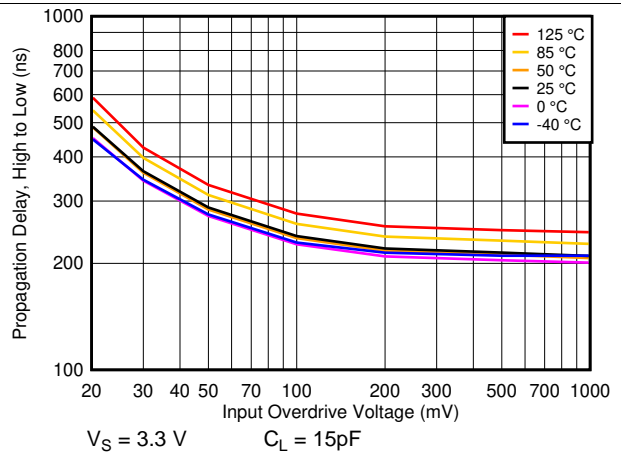

Figure 36.  $T_{PHL}$  Response Time vs. Overdrive at 3.3V

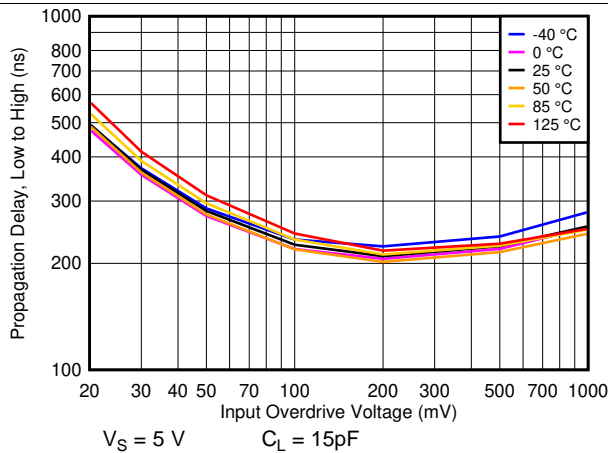

Figure 37.  $T_{PLH}$  Response Time vs. Overdrive at 5V

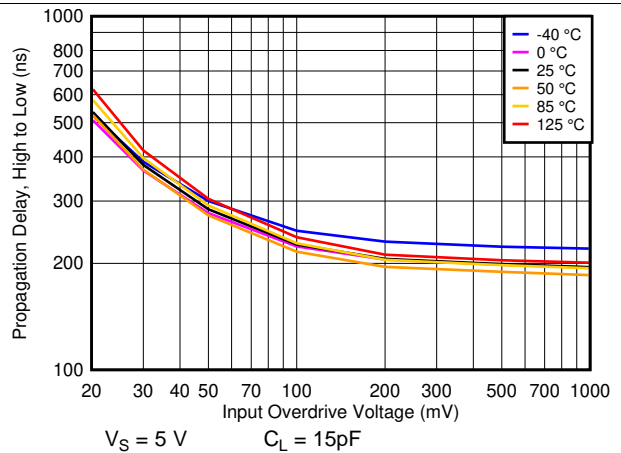
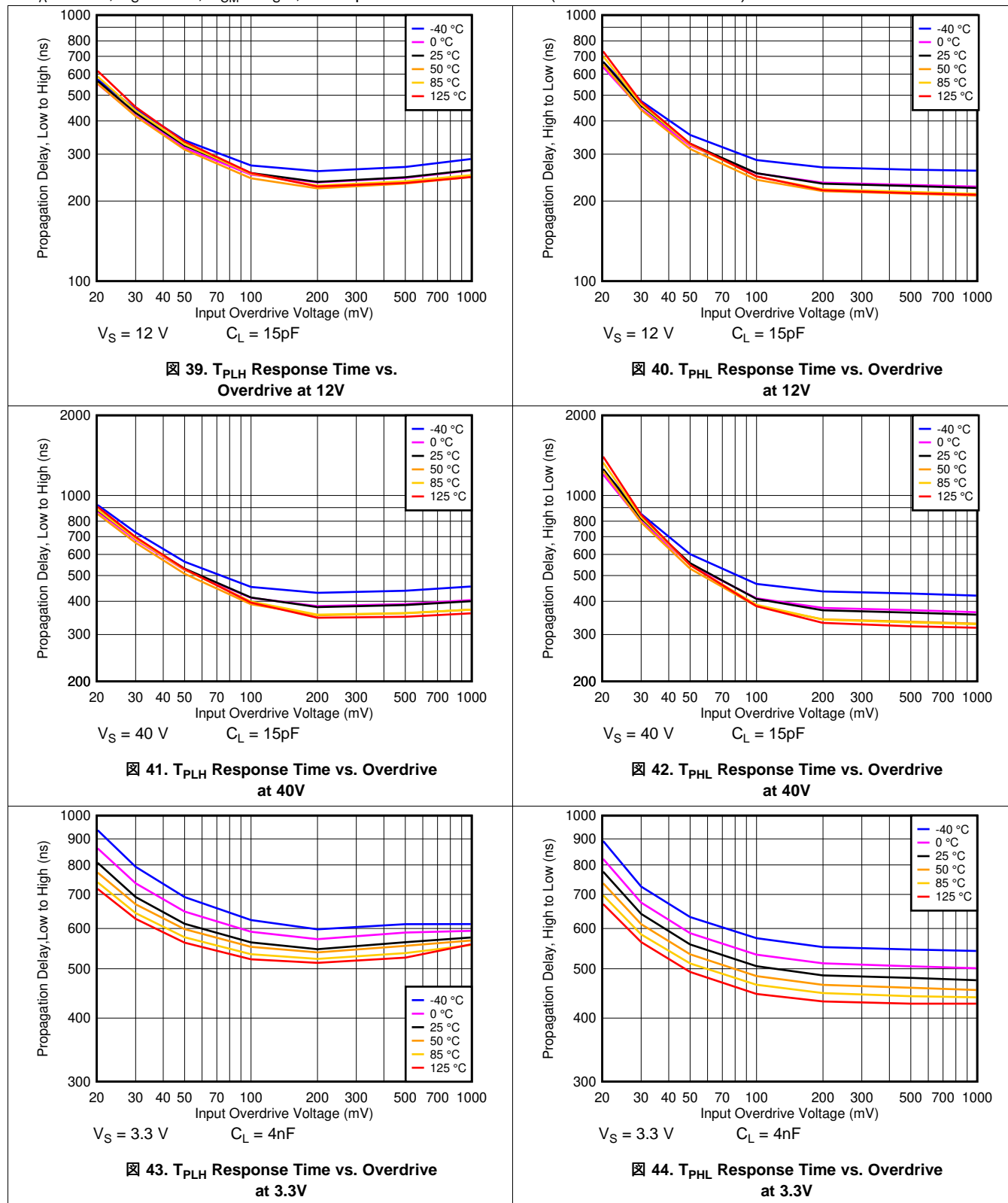

Figure 38.  $T_{PHL}$  Response Time vs. Overdrive at 5V

Typical Characteristics (continued)

at  $T_A = 25^\circ\text{C}$ ,  $V_S = 12\text{ V}$ ,  $V_{CM} = V_S/2$ , and input overdrive = 100 mV (unless otherwise noted)



### Typical Characteristics (continued)

at  $T_A = 25^\circ\text{C}$ ,  $V_S = 12\text{ V}$ ,  $V_{CM} = V_S/2$ , and input overdrive = 100 mV (unless otherwise noted)

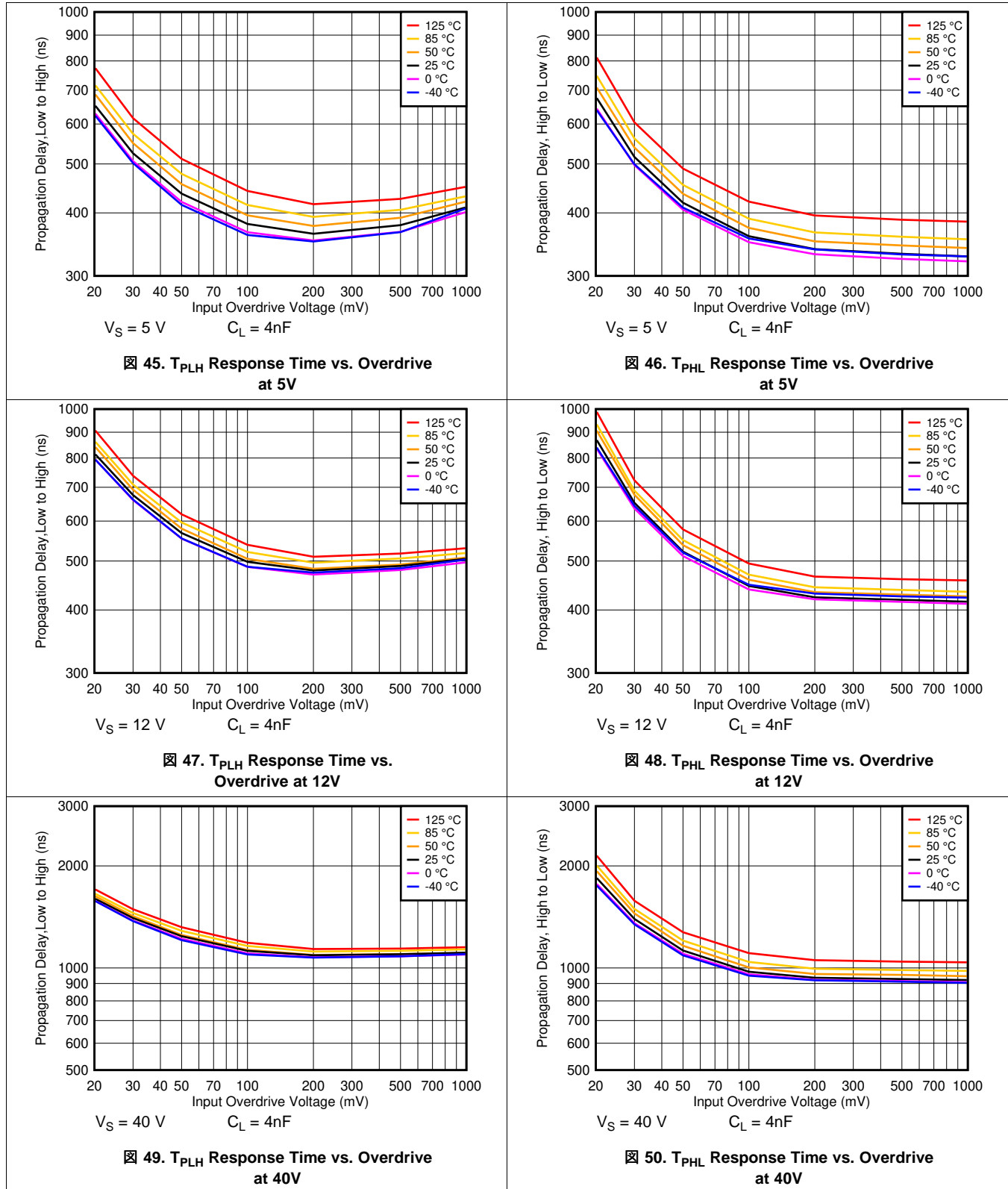

Typical Characteristics (continued)

at  $T_A = 25^\circ\text{C}$ ,  $V_S = 12\text{ V}$ ,  $V_{CM} = V_S/2$ , and input overdrive = 100 mV (unless otherwise noted)

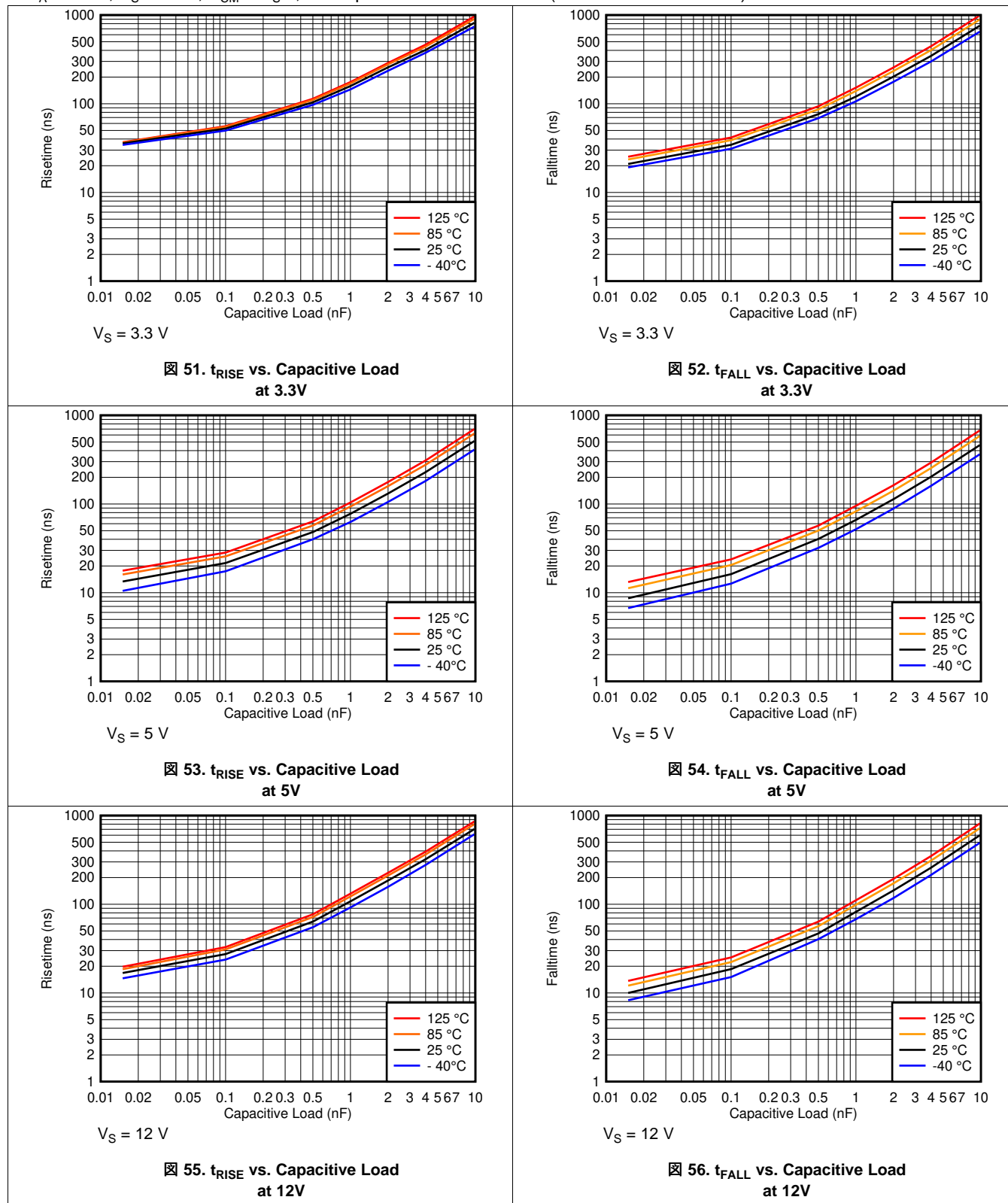

Typical Characteristics (continued)

at  $T_A = 25^\circ\text{C}$ ,  $V_S = 12\text{ V}$ ,  $V_{CM} = V_S/2$ , and input overdrive = 100 mV (unless otherwise noted)

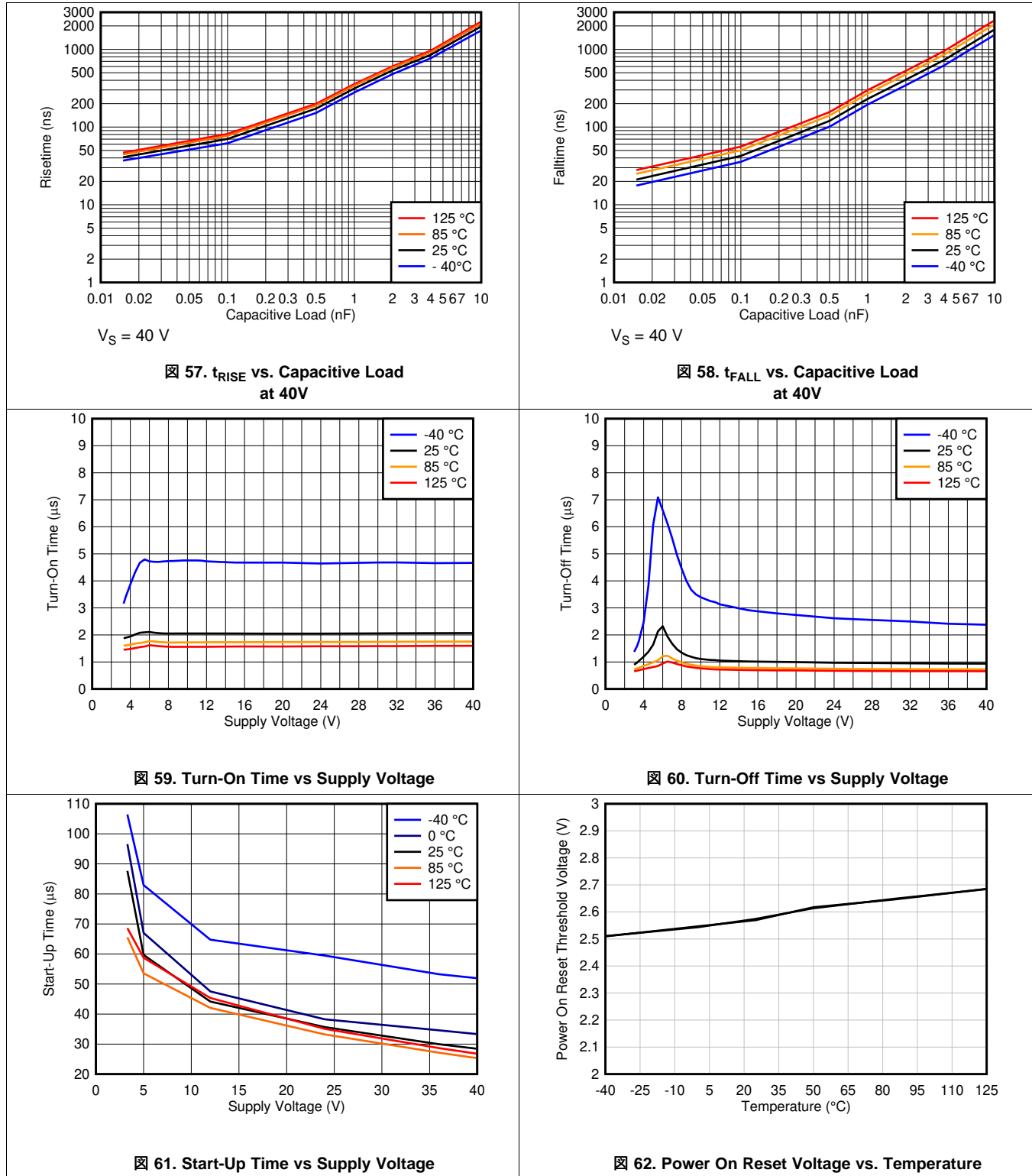



## 8 Detailed Description

### 8.1 Overview

The TLV1805 comparator features a rail-to-rail inputs with a push-pull output stage that operates at supply voltages as high as 40 V or  $\pm 20$  V. The rail-to-rail input stage enables detection of signals close to the supply and ground while the push-pull output stage creates fast transition edges to either supply rail. A low supply current of 135  $\mu$ A per channel with small, space-saving packages, makes these comparators versatile for use in a wide range of applications, from portable to industrial.

### 8.2 Functional Block Diagram

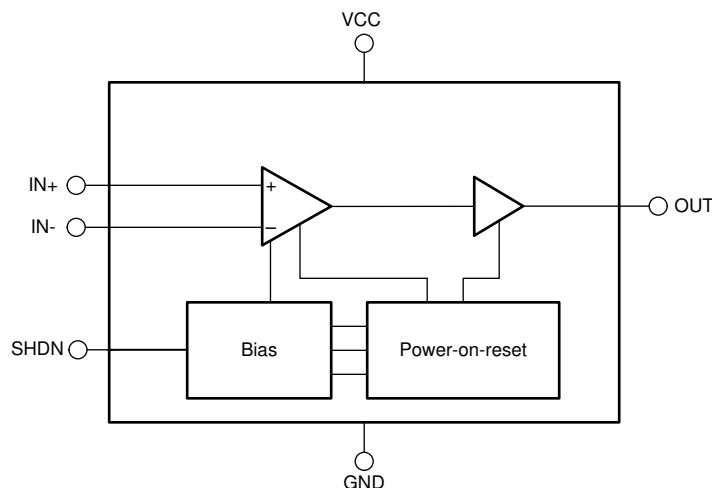

### 8.3 Feature Description

#### 8.3.1 Rail to Rail Inputs

The TLV1805 comparator features a CMOS input with a common-mode range that includes both supply rails. The TLV1805-Q1 is designed to prevent phase inversion when the input pins exceed the supply voltage.

#### 8.3.2 Power On Reset

The TLV1805 incorporates a power-on reset that holds the output in a High-Z state until the minimum operating supply voltage has been reached for at least 20 $\mu$ s. After this time the output will start responding to the inputs. This feature prevents false outputs during power-up and power-down.

#### 8.3.3 High Power Push-Pull Output

The push-pull output stage, which is unique for high-voltage comparators, offers the advantage of allowing the output to actively drive the load to either supply rail with a fast edge rate. A high output sink and source peak current of over 100mA allows quickly charging and discharging capacitive loads such as cables and power MOSFET gates. Caution must be taken to ensure that the package power dissipation is not exceeded when switching at these high supply voltages. See [Figure 22](#) for the output current derating curve.

#### 8.3.4 Shutdown Function

The TLV1805 has a logic level SHDN input. When the shutdown SHDN input is 1.4V above V-, the TLV1805 is disabled. When disabled, the output becomes high impedance (Hi-Z), and the supply current drops to below 10 $\mu$ A. The input bias current remains unchanged. Voltages may still be applied to the comparator inputs as long as V+ power is still applied and the applied input voltages are still within the specified input voltage range.

## Feature Description (continued)

### 注意

The maximum voltage on the shutdown pin is +5.5V referred to V-, regardless of supply voltage. Connect the SHDN pin to V- if shutdown is not used. Do not float the SHDN pin.

A high value pull-up or pull-down resistor on the output may be required if a specific logic level is required during shutdown (when the output is High-Z). This prevents logic inputs from floating to illegal states when the comparator output is in High-Z mode.

Since the Shutdown threshold voltage is a tested parameter, the shutdown pin can also be used as a second comparison input to provide a secondary measurement, such as overvoltage monitoring, as shown in the [P-Channel Reverse Current Protection With Overvoltage Protection](#) circuit.

### 8.3.5 Internal Hysteresis

The TLV1805 contains 14mV of internal hysteresis.

The hysteresis transfer curve is shown in [Figure 63](#). This curve is a function of three components:  $V_{TH}$ ,  $V_{OS}$ , and  $V_{HYST}$ :

- $V_{TH}$  is the actual set voltage or threshold trip voltage.
- $V_{OS}$  is the internal offset voltage between  $V_{IN+}$  and  $V_{IN-}$ . This voltage is added to  $V_{TH}$  to form the actual trip point at which the comparator must respond to change output states.
- $V_{HYST}$  is the internal hysteresis (or trip window) that is designed to reduce comparator sensitivity to noise (14 mV for the TLV1805).

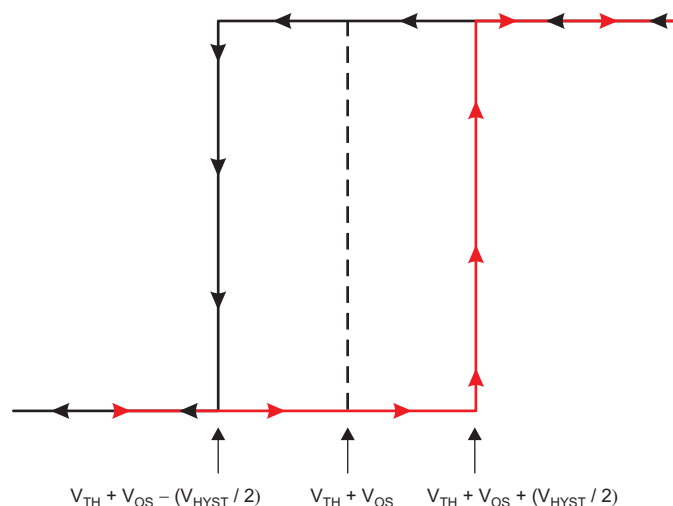

**Figure 63. Hysteresis Transfer Curve**

## 8.4 Device Functional Modes

### 8.4.1 External Hysteresis

External Hysteresis may be added to further improve response to noisy or slow-moving input signals.

## Device Functional Modes (continued)

### 8.4.1.1 Inverting Comparator With Hysteresis

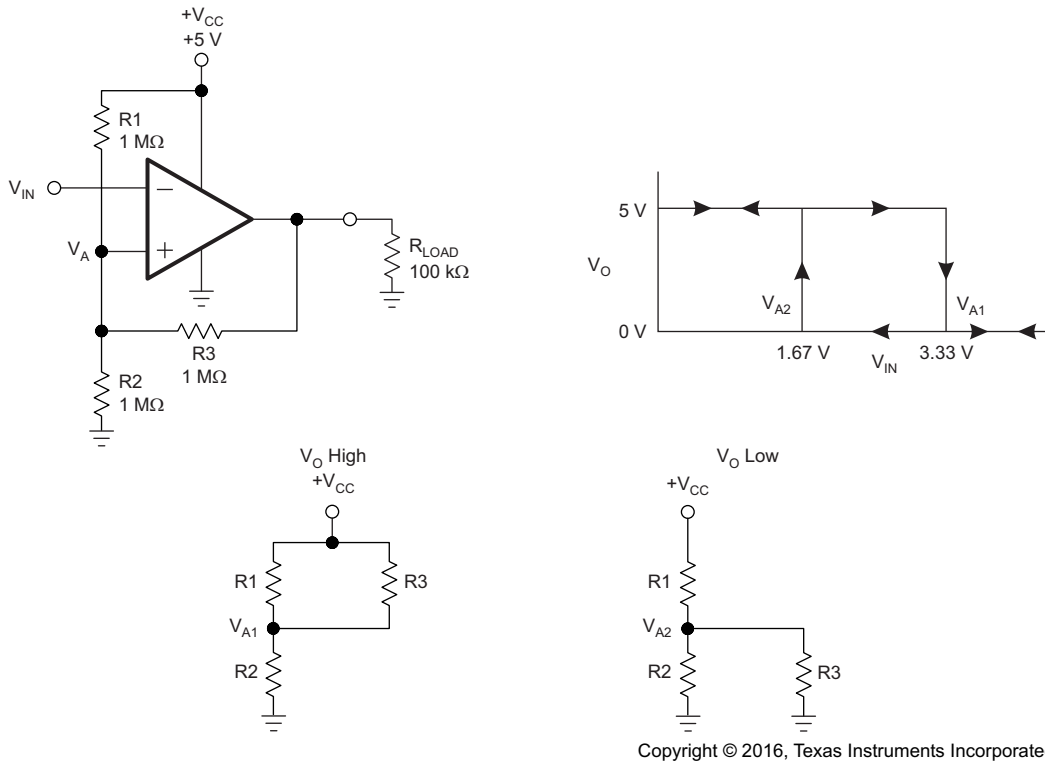

Copyright © 2016, Texas Instruments Incorporated

FIG 64. TLV1805 in an Inverting Configuration With Hysteresis

The inverting comparator with hysteresis requires a three-resistor network that is referenced to the comparator supply voltage ( $V_{CC}$ ), as shown in FIG 64. When  $V_{IN}$  at the inverting input is less than  $V_A$ , the output voltage is high (for simplicity, assume  $V_O$  switches as high as  $V_{CC}$ ). The three network resistors can be represented as  $R1 \parallel R3$  in series with  $R2$ . 式 1 defines the high-to-low trip voltage ( $V_{A1}$ ).

$$V_{A1} = V_{CC} \times \frac{R2}{(R1 \parallel R3) + R2} \quad (1)$$

When  $V_{IN}$  is greater than  $V_A$ , the output voltage is low, very close to ground. In this case, the three network resistors can be presented as  $R2 \parallel R3$  in series with  $R1$ . Use 式 2 to define the low to high trip voltage ( $V_{A2}$ ).

$$V_{A2} = V_{CC} \times \frac{R2 \parallel R3}{R1 + (R2 \parallel R3)} \quad (2)$$

式 3 defines the total hysteresis provided by the network.

$$\Delta V_A = V_{A1} - V_{A2} \quad (3)$$

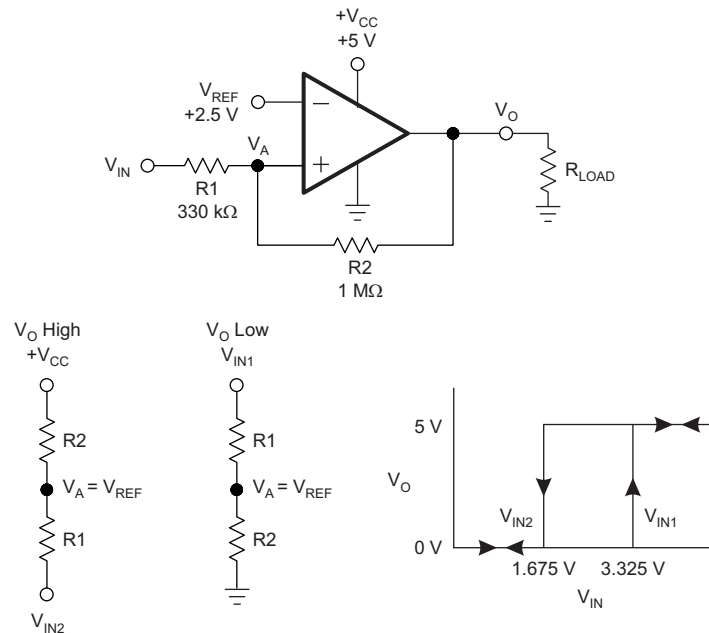
**Device Functional Modes (continued)**
**8.4.1.2 Noninverting Comparator With Hysteresis**

Copyright © 2016, Texas Instruments Incorporated

**FIG 65. TLV1805-Q1 in a Noninverting Configuration With Hysteresis**

A noninverting comparator with hysteresis requires a two-resistor network, as shown in FIG 65, and a voltage reference ( $V_{REF}$ ) at the inverting input. When  $V_{IN}$  is low, the output is also low. For the output to switch from low to high,  $V_{IN}$  must rise to  $V_{IN1}$ . Use 式 4 to calculate  $V_{IN1}$ .

$$V_{IN1} = R1 \times \frac{V_{REF}}{R2} + V_{REF} \quad (4)$$

When  $V_{IN}$  is high, the output is also high. For the comparator to switch back to a low state,  $V_{IN}$  must drop to  $V_{IN2}$  such that  $V_A$  is equal to  $V_{REF}$ . Use 式 5 to calculate  $V_{IN2}$ .

$$V_{IN2} = \frac{V_{REF} (R1 + R2) - V_{CC} \times R1}{R2} \quad (5)$$

The hysteresis of this circuit is the difference between  $V_{IN1}$  and  $V_{IN2}$ , as shown in 式 6.

$$\Delta V_{IN} = V_{CC} \times \frac{R1}{R2} \quad (6)$$

## 9 Application and Implementation

### 注

Information in the following applications sections is not part of the TI component specification, and TI does not warrant its accuracy or completeness. TI's customers are responsible for determining suitability of components for their purposes. Customers should validate and test their design implementation to confirm system functionality.

### 9.1 Application Information

The TLV1805 family of devices can be used in a wide variety of applications, such as MOSFET gate drivers, zero crossing detectors, window comparators, over and undervoltage detectors, and high-side voltage sense circuits.

### 9.2 Typical Applications

Comparators are used to differentiate between two different signal levels. For example, a comparator differentiates between an over-temperature and normal-temperature condition. However, noise or signal variation at the comparison threshold causes multiple transitions. This application example sets upper and lower hysteresis thresholds to eliminate the multiple transitions caused by noise.



图 66. Comparator with Hysteresis

#### 9.2.1 Design Requirements

The design requirements are as follows:

- Supply voltage: 5 V
- Input: 0 V to 5 V
- Lower threshold ( $V_L$ ) = 2.3 V  $\pm$ 0.1 V
- Upper threshold ( $V_H$ ) = 2.7 V  $\pm$ 0.1 V
- $V_H - V_L = 2.4$  V  $\pm$ 0.1 V
- Low-power consumption

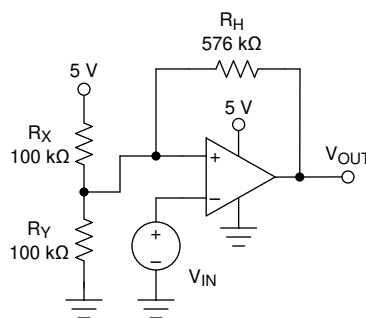
#### 9.2.2 Detailed Design Procedure

A small change to the comparator circuit can be made to add hysteresis. Hysteresis uses two different threshold voltages to avoid the multiple transitions introduced in the previous circuit. The input signal must exceed the upper threshold ( $V_H$ ) to transition low, or below the lower threshold ( $V_L$ ) to transition high.

图 66 illustrates hysteresis on a comparator. Resistor  $R_H$  sets the hysteresis level.

When the output is at a logic high (5 V),  $R_H$  is in parallel with  $R_X$ . This configuration drives more current into  $R_Y$ , and raises the threshold voltage ( $V_H$ ) to 2.7 V. The input signal must drive above  $V_H = 2.7$  V to cause the output to transition to logic low (0 V).

## Typical Applications (continued)

When the output is at logic low (0 V),  $R_h$  is in parallel with  $R_y$ . This configuration reduces the current into  $R_y$ , and reduces the threshold voltage to 2.3 V. The input signal must drive below  $V_L = 2.3$  V to cause the output to transition to logic high (5 V).

For more details on this design, refer to Precision Design [TIPD144](#), *Comparator with Hysteresis Reference Design*.

### 9.2.3 Application Curve

Figure 67 shows the upper and lower thresholds for hysteresis. The upper threshold is 2.76 V and the lower threshold is 2.34 V, both of which are close to the design target.

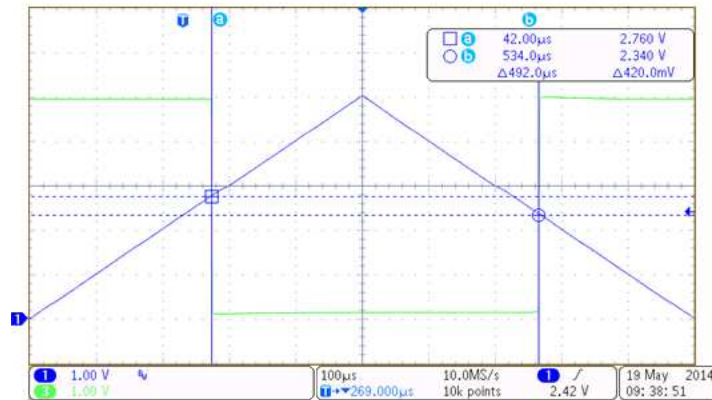
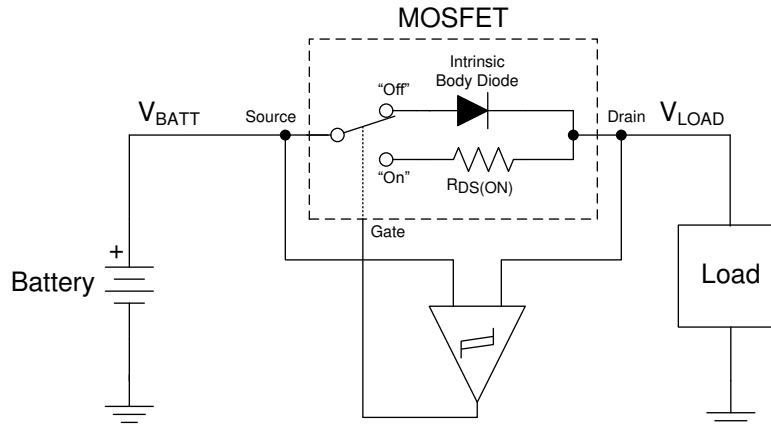

Figure 67. TLV1805 Upper and Lower Threshold with Hysteresis

## Typical Applications (continued)

### 9.2.4 Reverse Current Protection Using MOSFET and TLV1805

An N-Channel or P-Channel MOSFET may be used to protect against reverse current. Reverse current is defined as current flowing from the load ( $V_{LOAD}$ ) to the source ( $V_{BATT}$ ). Both the P-Channel and N-Channel circuits work on the same basic principle, where a comparator monitors the voltage across the MOSFET's Source and Drain terminals (monitoring  $V_{DS}$ ). The described circuits also protect against reverse voltage.



✉ 68. Simplified Operational Theory

When the current is flowing from the battery ( $V_{BATT}$ ) to the load ( $V_{LOAD}$ ), the battery voltage will be higher than the load voltage due to voltage drop across the MOSFET caused by the  $R_{DS(ON)}$  or the intrinsic body diode forward voltage drop. The comparator will detect this and turn "on" the MOSFET so that the load current is now flowing through the low loss  $R_{DS(ON)}$  path.

In a reverse current condition,  $V_{LOAD}$  will be higher than  $V_{BATT}$ . The comparator will detect this and drive the gate to set  $V_{GS} = 0$  to turn "off" the MOSFET (non-conducting). The body diode is reverse biased and will block current flow.

For a P-Channel MOSFET, the gate must be driven at least 4V or more *below* the battery voltage to turn "on" the MOSFET.

For a N-Channel MOSFET, the gate must be driven 4V or more *above* the battery voltage to turn "on" the MOSFET. If a higher voltage is not available in the system, a charge pump is usually required to generate a voltage higher than the battery voltage to provide the necessary positive gate drive voltage.

#### 9.2.4.1 Minimum Reverse Current

There is a minimum amount of reverse current that is needed to trip the comparator. To detect this reverse current, a voltage must be dropped across the MOSFET ( $V_{MEAS}$ ).

When the MOSFET is off,  $V_{GS}$  will be in the -600mV to -1V range due to the forward voltage drop ( $V_F$ ) of the MOSFET body diode. Response to this large voltage will be immediate.

However, with the MOSFET "on" (conducting), the current required to create the trip voltage will be much greater. The trip voltage drop required across the MOSFET  $R_{DS(ON)}$  will be the comparator offset voltage plus half of the hysteresis.

The maximum offset voltage of the TLV1805 is 5mV with a typical hysteresis of 14mV. The trip voltage can be calculated from:

$$V_{TRIP} = V_{OS(max)} + (V_{HYST} / 2) = 5 \text{ mV} + 7 \text{ mV} = 12 \text{ mV} \quad (7)$$

The actual current trip point will depend on the MOSFET  $R_{DS(ON)}$  and  $V_{GS}$  drive level. Assuming the MOSFET has a 22 m $\Omega$  on resistance, the trip current is found from:

$$I_{TRIP} = V_{TRIP} / R_{DS(ON)} = 12 \text{ mV} / 22 \text{ m}\Omega = 546\text{mA} \quad (8)$$

## Typical Applications (continued)

### 9.2.4.2 N-Channel Reverse Current Protection Circuit

In order to turn "on" the N-Channel MOSFET, the MOSFET gate must be brought "High" above  $V_{BATT}$ . If a higher voltage is not available, a charge pump circuit is required to provide the comparator with a supply voltage above  $V_{BATT}$ .

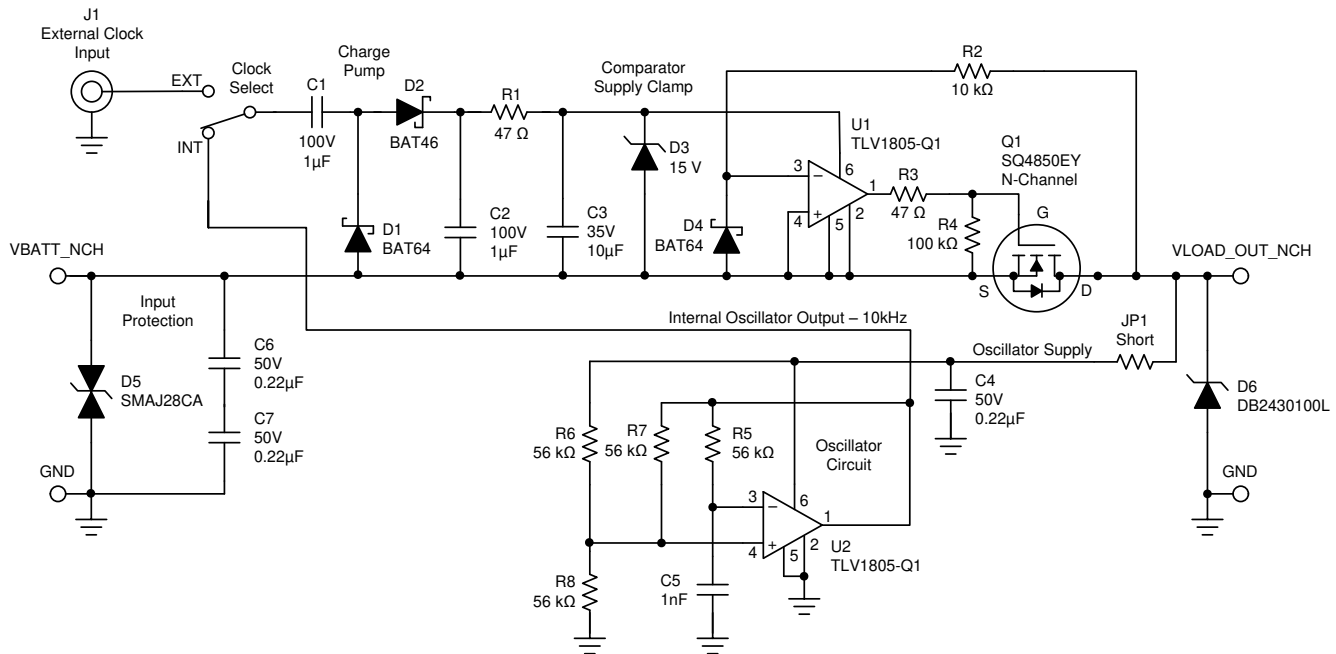

Fig 69. N-Channel Reverse Current Schematic with Oscillator

C1, D1, D2 & C2 form the charge pump. The AC drive signal is applied through C1 into the charge pump. The result is a voltage across C2 that is approximately equal to the peak-to-peak amplitude of the AC waveform, minus 700mV. If a 12Vpp waveform is applied to the C1 input, 11.3V will be generated across C2. This voltage is on top of the  $V_{BATT}$  voltage, so the voltage seen from the D2-C2 junction ground is 23.3V. This provides the needed higher voltage to drive the MOSFET and power the comparator.

An external oscillator source may be used, such as the gate drive output of a switcher, system clock or any available clock source in the 1kHz to 10MHz range. The charge pump should be fed by a 50 percent duty cycle square wave source of 5Vpp or more. Since the input capacitor of the charge-pump effectively AC-couples the input, the oscillator may be ground referenced.

R1 and D3 form the comparator supply clamp to limit the gate drive to prevent exceeding the  $V_{GS(MAX)}$  of the MOSFET during an overvoltage event. R1 must be sized to dissipate any expected overvoltage.

D4 and R2 clamp the input should  $V_{BATT}$  drop below  $V_{LOAD}$  (as in a supply reversal).

The output diode D6 is used to anchor the output during light or floating loads. At light or no loads, there is a possibility the MOSFET could turn on due to the comparator offset voltage. The diode provides enough of a negative leakage to turn the MOSFET off.

#### 9.2.4.2.1 N-Channel Oscillator Circuit

The oscillation frequency is determined by R5 and C5. The default configuration oscillates around 10kHz (depending on RC component tolerances). For further information on selecting these RC values, please see the Engineers Cookbook Circuit entitled [Oscillator Circuit \(SNOA990\)](#). Do note that R5 does present an AC load to the oscillator output, and should be sized appropriately to minimize the peak charging currents of C5 (use large resistors and small capacitors).



## Typical Applications (continued)

The output amplitude is roughly equivalent to the  $V_{LOAD}$  voltage minus the TLV1805 output saturation (approximately 300mV). With a maximum supply voltage of 40V for the TLV1805, the oscillator circuit is capable of generating up to 39Vpp!

The TLV1805 oscillator typically starts oscillating when  $V_{LOAD}$  reaches 2.8V, though full specified operation does not occur until 3.3V.

For more information, please see the TLV1805-Q1 Evaluation Module Users Guide [TLV1805-Q1 Evaluation Module Users Guide \(SNOU158\)](#).

### 9.2.5 P-Channel Reverse Current Protection Circuit

Figure 70 shows the P-Channel circuit. In order to turn "on" the P-Channel MOSFET, the gate must be brought "Low" below  $V_{BATT}$ . To accomplish this, the comparators inverting input is tied to the battery side of the MOSFET to set the output low during forward current.

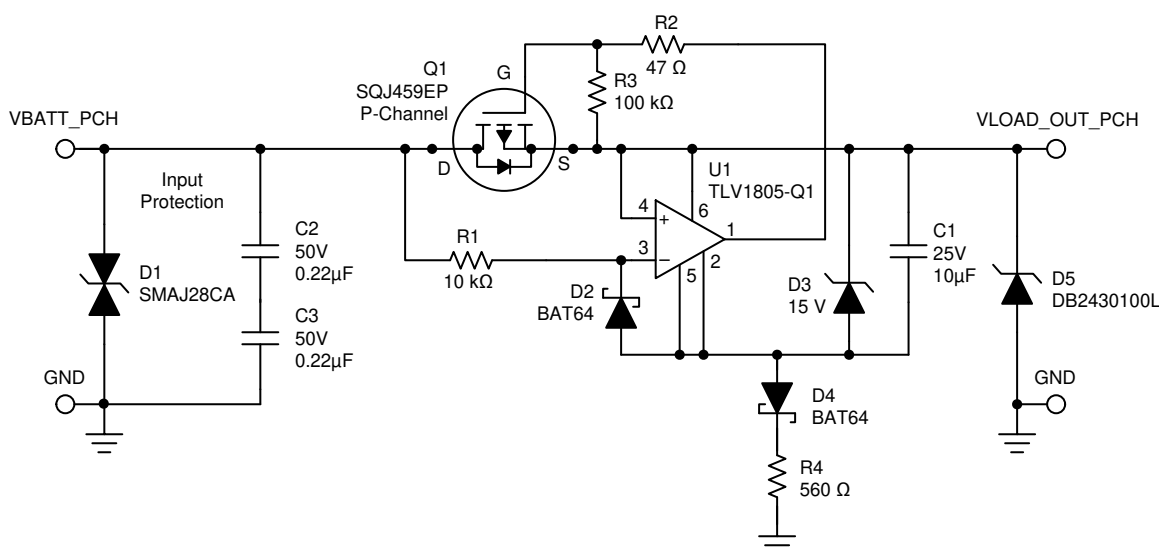

Figure 70. P-Channel Reverse Current Schematic

This design implements a "floating ground" topology, using D3, D4 and R12, to allow for clamping the comparator supply voltage as to not exceed the  $V_{GS(MAX)}$  of the MOSFET. During a reverse voltage or supply drop, D4 also prevents C1 from discharging to allow some standby time to keep the comparator powered during the event.

During "normal" forward current operation, the quiescent current of the comparator circuit flows through D4 and R4. D3 provides the clamping during an overvoltage event.

R4 is sized to allow for minimum voltage drop during "normal" operation, but also to allow for dissipation during overvoltage events. R4 will see the battery voltage minus the D3 Zener voltage during an overvoltage event. Since the comparator supply voltage is clamped by D3, the maximum battery voltage is determined by the power dissipated by R4 and the  $V_{DS(MAX)}$  of the MOSFET.

R2 limits the gate current should there be any transients and should be a low value to allow the peak currents needed to drive the MOSFET gate capacitance. R3 provides the pull-down needed when the comparator output goes high-Z during power-off to ensure the gate is pulled to zero volts to turn off the MOSFET.

R1 and D2 clamp the input voltage should the  $V_{BATT}$  input go below the floating ground Voltage (such as in a battery reversal). A bonus feature is that during a reverse battery voltage condition, D2 and R1 pull the floating ground down towards the negative potential, providing power to the comparator during reverse voltage.

The output clamp diode D5 is used to anchor the output during light or floating loads. At light or no loads, there is a possibility the MOSFET could turn on due to the comparator offset voltage. The diode provides enough of a negative leakage to turn the MOSFET off.

### Typical Applications (continued)

If shutdown of the comparator circuit is desired, a transistor or MOSFET switch can be placed between the ground end of R4 and ground. The MOSFET will be in body diode mode when the comparator is disabled.

#### 9.2.6 P-Channel Reverse Current Protection With Overvoltage Protection

The SHDN pin can be utilized to add Overvoltage Protection (OVP) by adding a second MOSFET, zener diode and resistor, as shown in [Figure 71](#).

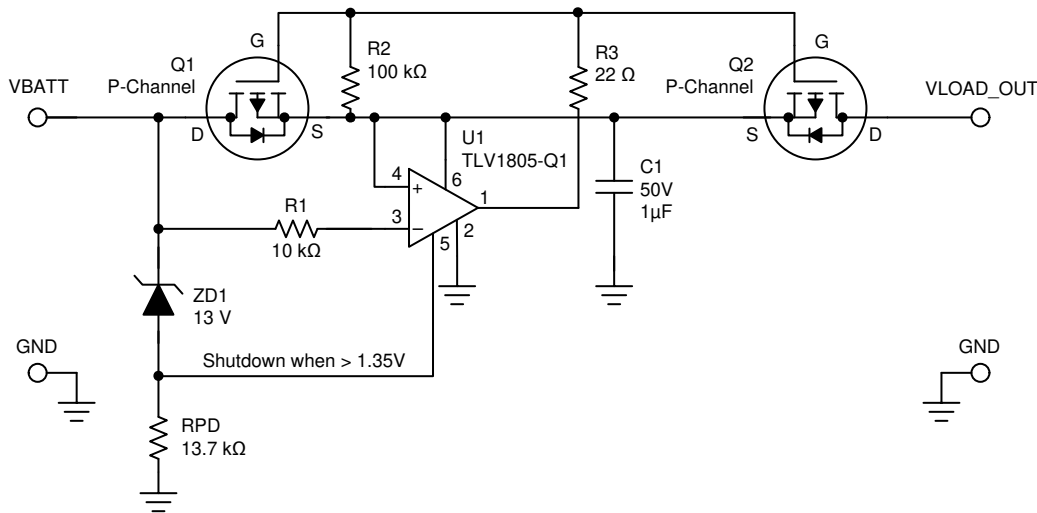

**Figure 71. Adding Overvoltage Protection Using SHDN Pin**

When the SHDN pin is pulled 1.35 V above V-, the comparator is placed in shutdown. During shutdown, the comparator output goes Hi-Z and R2 pulls the gate and source together to turn off the MOSFET ( $V_{GS} = 0$  V).

RPD pulls the SHDN pin low while the Zener diode is not conducting ( $< V_Z$ ). When ZD1 reaches its breakdown voltage and starts conducting, it will pull RPD up to a voltage calculated to place  $> 1.35$  V on the shutdown pin.

The Zener diode ZD1 should be chosen so that the breakdown voltage ( $V_B$ ) is 1.35 V below the desired overvoltage point. The Zener should have low sub-threshold leakage and a sharp knee, such as the low power 1N47xx or BZD series.

The pull-down resistor RPD should be chosen to create 1.35 V at the desired Zener diode current (usually 100µA to 1mA) at the Zener breakdown voltage. Actual resistor value should be verified on the bench due to differences in actual Zener diode threshold voltages.

If a 14.3 V overvoltage trip point (OVP) is desired, the Zener Diode voltage should be 12.95 V. We will choose a 100µA Zener current. The required Zener diode breakdown voltage is determined from:

$$V_B = V_{OV} - 1.35 \text{ V} = 14.3 \text{ V} - 1.35 \text{ V} = 12.95 \text{ V} \tag{9}$$

$$RPD = 1.35 \text{ V} / 100 \text{ } \mu\text{A} = 13.5 \text{ k}\Omega \text{ (13.7k}\Omega \text{ nearest value)} \tag{10}$$

Resistor RPD may be split into two resistors to create a voltage divider if more precise trip points are needed, or a more convenient zener voltage is desired. Series voltage references can also be used if more accuracy is desired. A second resistor in series with the Zener or reference can extend the breakdown voltage.

The maximum voltage allowed on the Shutdown pin is 5.5V, so make sure the highest  $V_{BATT}$  voltage does not exceed 5.5 V.

Note that the above circuit, as shown for simplicity, does not protect against reverse voltage. Reverse clamping diodes would be needed on the -IN, SHDN and Load Output. Also make sure  $V_{BATT}$  does not exceed the  $V_{GS(MAX)}$  of the MOSFET.

## Typical Applications (continued)

### 9.2.7 OR'ing MOSFET Controller

The previous reverse current circuits may be combined to create an OR'ing supply controller, utilizing either the P-Channel or N-Channel topologies.

For the previous P-Channel circuit, if no negative input voltages are possible, and the input voltage is below the MOSFET's  $V_{GS(MAX)}$ , then D3, D4 and R4 may be eliminated (the D2 anode, U1 pins 2 and 5, and C1 can be directly grounded).

For the N-Channel circuit, the oscillator drive can be shared between the channels, or eliminated if a higher system voltage is available to provide the higher voltage.



图 72. N-Channel OR'ing MOSFET Controller

## 10 Power Supply Recommendations

The TLV1805 family of devices is specified for operation from 3.3 V to 40 V ( $\pm 1.65$  to  $\pm 20$  V); many specifications apply from  $-40^{\circ}\text{C}$  to  $+125^{\circ}\text{C}$ . Parameters that can exhibit significant variance with regard to operating voltage or temperature are presented in the *Typical Characteristics* section.

### 注意

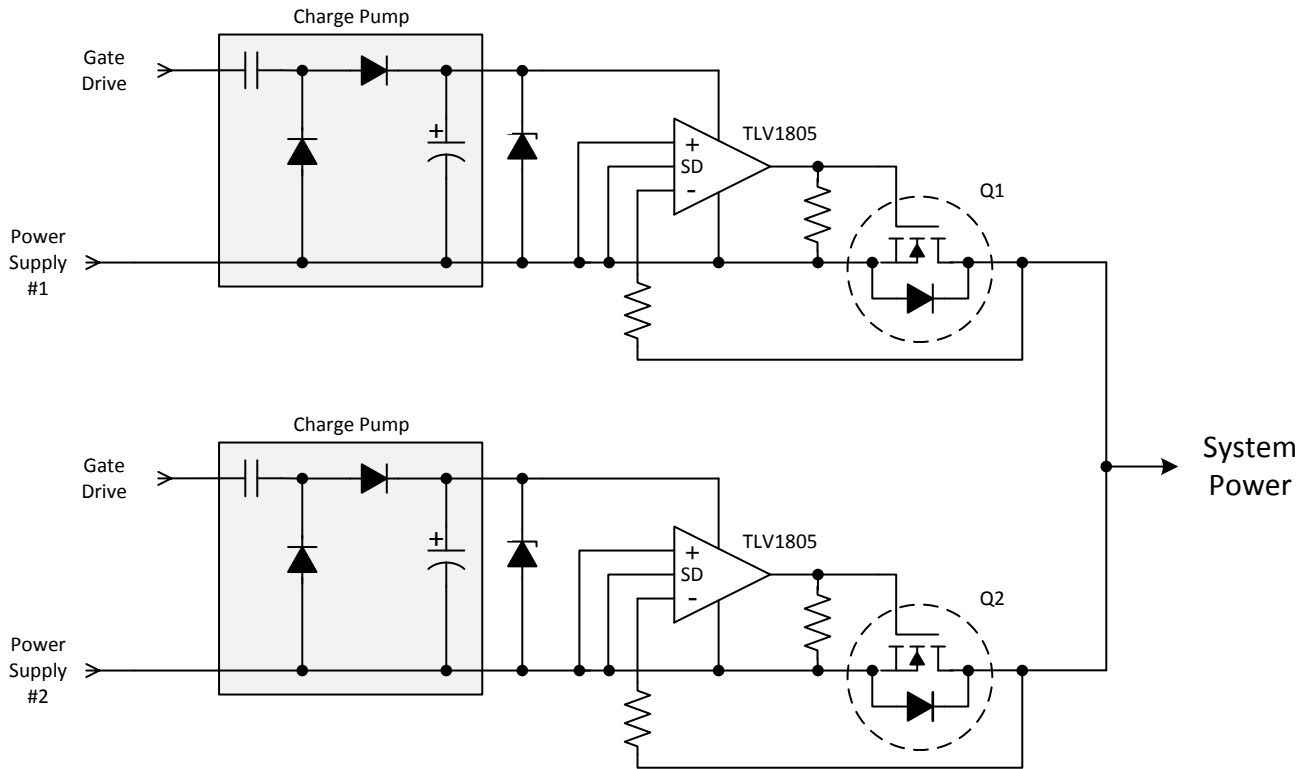
Supply voltages larger than 40 V can permanently damage the device; see the *Recommended Operating Conditions* section.

Place 0.1- $\mu\text{F}$  bypass capacitors close to the power-supply pins to reduce errors coupling in from noisy or high-impedance power supplies. For more detailed information on bypass capacitor placement; see the [Layout Guidelines](#) section.

The TLV1805 does not contain reverse battery protection, so applying negative voltage to the supply pins must be avoided. The TLV1805 cannot withstand ISO 16750 type waveforms alone and requires external protection circuitry.

## 11 Layout

### 11.1 Layout Guidelines

Comparators are very sensitive to input noise. For best results, maintain the following layout guidelines:

- Use a printed circuit board (PCB) with a good, unbroken low-inductance ground plane. Proper grounding (use of ground plane) helps maintain specified performance of the TLV1805 family of devices.
- To minimize supply noise, place a decoupling capacitor (0.1- $\mu\text{F}$  ceramic, surface-mount capacitor) as close as possible to  $V_S$  as shown in [Figure 73](#).
- On the inputs and the output, keep lead lengths as short as possible to avoid unwanted parasitic feedback around the comparator. Keep inputs away from the output.
- Solder the device directly to the PCB rather than using a socket.
- Run the ground pin ground trace under the device up to the bypass capacitor, shielding the inputs from the outputs.

### 11.2 Layout Example



图 73. Oscillator Circuit Layout Example

## 12 デバイスおよびドキュメントのサポート

### 12.1 ドキュメントのサポート

#### 12.1.1 関連資料

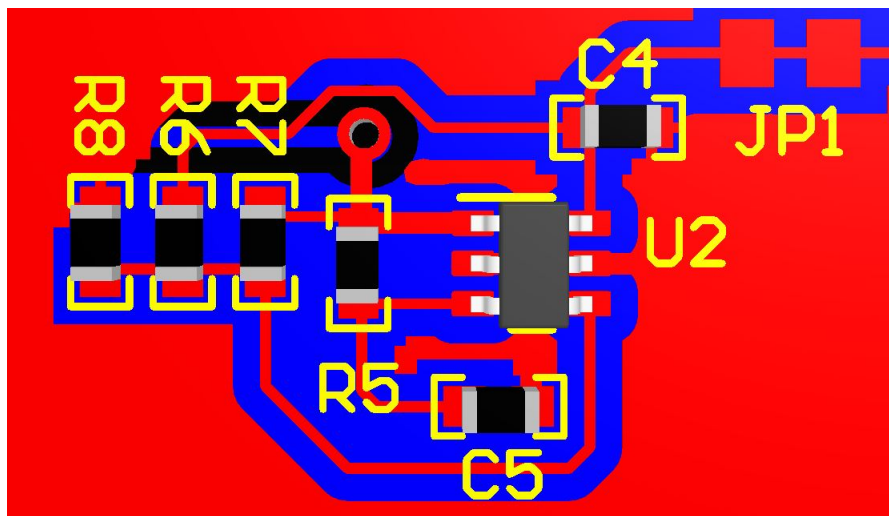
『*Precision Design*、ヒステリシス付きコンパレータのリファレンス・デザイン』、TIDU020

『リファレンス・デザイン、ウィンドウ・コンパレータのリファレンス・デザイン』、TIPD178

『*EVM ユーザー・ガイド*、TLV1805-Q1 逆電流評価モジュール・ユーザー・ガイド』、SNOU158

### 12.2 ドキュメントの更新通知を受け取る方法

ドキュメントの更新についての通知を受け取るには、[ti.com](http://ti.com)のデバイス製品フォルダを開いてください。右上の「アラートを受け取る」をクリックして登録すると、変更されたすべての製品情報に関するダイジェストを毎週受け取れます。変更の詳細については、修正されたドキュメントに含まれている改訂履歴をご覧ください。

### 12.3 コミュニティ・リソース

The following links connect to TI community resources. Linked contents are provided "AS IS" by the respective contributors. They do not constitute TI specifications and do not necessarily reflect TI's views; see TI's [Terms of Use](#).

**TI E2E™オンライン・コミュニティ** *TIのE2E (Engineer-to-Engineer) コミュニティ*。エンジニア間の共同作業を促進するために開設されたものです。e2e.ti.comでは、他のエンジニアに質問し、知識を共有し、アイデアを検討して、問題解決に役立てることができます。

**設計サポート** *TIの設計サポート* 役に立つE2Eフォーラムや、設計サポート・ツールをすばやく見つけることができます。技術サポート用の連絡先情報も参照できます。

### 12.4 商標

E2E is a trademark of Texas Instruments.

### 12.5 静電気放電に関する注意事項



すべての集積回路は、適切なESD保護方法を用いて、取扱いと保存を行うようにして下さい。

静電気放電はわずかな性能の低下から完全なデバイスの故障に至るまで、様々な損傷を与えます。高精度の集積回路は、損傷に対して敏感であり、極めてわずかなパラメータの変化により、デバイスに規定された仕様に適合しなくなる場合があります。

### 12.6 Glossary

**SLYZ022** — *TI Glossary*.

This glossary lists and explains terms, acronyms, and definitions.

## 13 メカニカル、パッケージ、および注文情報

以降のページには、メカニカル、パッケージ、および注文に関する情報が記載されています。これらの情報は、指定のデバイスに対して提供されている最新のデータです。このデータは予告なく変更されることがあり、ドキュメントが改訂される場合もあります。本データシートのブラウザ版を使用されている場合は、画面左側の説明をご覧ください。

**PACKAGING INFORMATION**

Orderable Device	Status (1)	Package Type	Package Drawing	Pins	Package Qty	Eco Plan (2)	Lead finish/ Ball material (6)	MSL Peak Temp (3)	Op Temp (°C)	Device Marking (4/5)	Samples
TLV1805DBVR	ACTIVE	SOT-23	DBV	6	3000	RoHS & Green	NIPDAU   SN	Level-1-260C-UNLIM	-40 to 125	1UBF	Samples

(1) The marketing status values are defined as follows:

**ACTIVE:** Product device recommended for new designs.

**LIFEBUY:** TI has announced that the device will be discontinued, and a lifetime-buy period is in effect.

**NRND:** Not recommended for new designs. Device is in production to support existing customers, but TI does not recommend using this part in a new design.

**PREVIEW:** Device has been announced but is not in production. Samples may or may not be available.

**OBSELETE:** TI has discontinued the production of the device.

(2) **RoHS:** TI defines "RoHS" to mean semiconductor products that are compliant with the current EU RoHS requirements for all 10 RoHS substances, including the requirement that RoHS substance do not exceed 0.1% by weight in homogeneous materials. Where designed to be soldered at high temperatures, "RoHS" products are suitable for use in specified lead-free processes. TI may reference these types of products as "Pb-Free".

**RoHS Exempt:** TI defines "RoHS Exempt" to mean products that contain lead but are compliant with EU RoHS pursuant to a specific EU RoHS exemption.

**Green:** TI defines "Green" to mean the content of Chlorine (Cl) and Bromine (Br) based flame retardants meet JS709B low halogen requirements of <=1000ppm threshold. Antimony trioxide based flame retardants must also meet the <=1000ppm threshold requirement.

(3) MSL, Peak Temp. - The Moisture Sensitivity Level rating according to the JEDEC industry standard classifications, and peak solder temperature.

(4) There may be additional marking, which relates to the logo, the lot trace code information, or the environmental category on the device.

(5) Multiple Device Markings will be inside parentheses. Only one Device Marking contained in parentheses and separated by a "-" will appear on a device. If a line is indented then it is a continuation of the previous line and the two combined represent the entire Device Marking for that device.

(6) Lead finish/Ball material - Orderable Devices may have multiple material finish options. Finish options are separated by a vertical ruled line. Lead finish/Ball material values may wrap to two lines if the finish value exceeds the maximum column width.

**Important Information and Disclaimer:**The information provided on this page represents TI's knowledge and belief as of the date that it is provided. TI bases its knowledge and belief on information provided by third parties, and makes no representation or warranty as to the accuracy of such information. Efforts are underway to better integrate information from third parties. TI has taken and continues to take reasonable steps to provide representative and accurate information but may not have conducted destructive testing or chemical analysis on incoming materials and chemicals. TI and TI suppliers consider certain information to be proprietary, and thus CAS numbers and other limited information may not be available for release.

In no event shall TI's liability arising out of such information exceed the total purchase price of the TI part(s) at issue in this document sold by TI to Customer on an annual basis.

**OTHER QUALIFIED VERSIONS OF TLV1805 :**

- Automotive : [TLV1805-Q1](#)

NOTE: Qualified Version Definitions:

- Automotive - Q100 devices qualified for high-reliability automotive applications targeting zero defects

# DBV0006A



## PACKAGE OUTLINE

SOT-23 - 1.45 mm max height

SMALL OUTLINE TRANSISTOR



4214840/G 08/2024

**NOTES:**

1. All linear dimensions are in millimeters. Any dimensions in parenthesis are for reference only. Dimensioning and tolerancing per ASME Y14.5M.
2. This drawing is subject to change without notice.
3. Body dimensions do not include mold flash or protrusion. Mold flash and protrusion shall not exceed 0.25 per side.
4. Leads 1,2,3 may be wider than leads 4,5,6 for package orientation.
5. Reference JEDEC MO-178.



# EXAMPLE BOARD LAYOUT

DBV0006A

SOT-23 - 1.45 mm max height

SMALL OUTLINE TRANSISTOR



LAND PATTERN EXAMPLE  
EXPOSED METAL SHOWN  
SCALE:15X

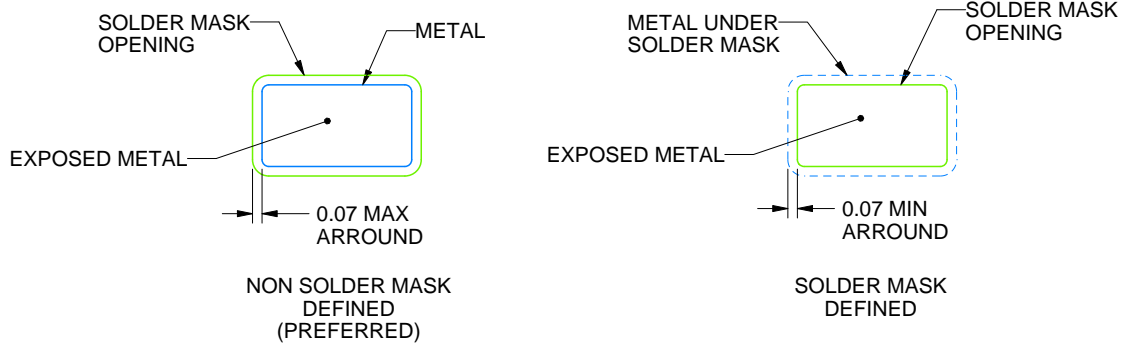

SOLDER MASK DETAILS

4214840/G 08/2024

NOTES: (continued)

6. Publication IPC-7351 may have alternate designs.
7. Solder mask tolerances between and around signal pads can vary based on board fabrication site.

# EXAMPLE STENCIL DESIGN

DBV0006A

SOT-23 - 1.45 mm max height

SMALL OUTLINE TRANSISTOR



SOLDER PASTE EXAMPLE  
BASED ON 0.125 mm THICK STENCIL  
SCALE:15X

4214840/G 08/2024

NOTES: (continued)

8. Laser cutting apertures with trapezoidal walls and rounded corners may offer better paste release. IPC-7525 may have alternate design recommendations.
9. Board assembly site may have different recommendations for stencil design.

## 重要なお知らせと免責事項

TI は、技術データと信頼性データ (データシートを含みます)、設計リソース (リファレンス・デザインを含みます)、アプリケーションや設計に関する各種アドバイス、Web ツール、安全性情報、その他のリソースを、欠陥が存在する可能性のある「現状のまま」提供しており、商品性および特定目的に対する適合性の黙示保証、第三者の知的財産権の非侵害保証を含むいかなる保証も、明示的または黙示的にかかわらず拒否します。

これらのリソースは、TI 製品を使用する設計の経験を積んだ開発者への提供を意図したものです。(1) お客様のアプリケーションに適した TI 製品の選定、(2) お客様のアプリケーションの設計、検証、試験、(3) お客様のアプリケーションに該当する各種規格や、その他のあらゆる安全性、セキュリティ、規制、または他の要件への確実な適合に関する責任を、お客様のみが単独で負うものとします。

上記の各種リソースは、予告なく変更される可能性があります。これらのリソースは、リソースで説明されている TI 製品を使用するアプリケーションの開発の目的でのみ、TI はその使用をお客様に許諾します。これらのリソースに関して、他の目的で複製することや掲載することは禁止されています。TI や第三者の知的財産権のライセンスが付与されている訳ではありません。お客様は、これらのリソースを自身で使用した結果発生するあらゆる申し立て、損害、費用、損失、責任について、TI およびその代理人を完全に補償するものとし、TI は一切の責任を拒否します。

TI の製品は、[TI の販売条件](#)、または [ti.com](#) やかかる TI 製品の関連資料などのいずれかを通じて提供する適用可能な条項の下で提供されています。TI がこれらのリソースを提供することは、適用される TI の保証または他の保証の放棄の拡大や変更を意味するものではありません。

お客様がいかなる追加条項または代替条項を提案した場合でも、TI はそれらに異議を唱え、拒否します。

郵送先住所 : Texas Instruments, Post Office Box 655303, Dallas, Texas 75265  
Copyright © 2024, Texas Instruments Incorporated