

SNx5HVD08 幅広い電源電圧範囲を持つ RS-485 トランシーバ

1 特長

- 3V~5.5V 電源で動作
- 無信号時電流電源の消費電力は 90mW 未満
- 開路、短絡、アイドル・バスのフェイルセーフ・レシーバ
- 1/8 ユニット負荷 (バス上に最大 256 ノード)
- 16kV HBM を超えるバス・ピンの ESD 保護
- 10Mbps で最適な信号品質を実現するためドライバ出力電圧のスルーレートを制限
- ANSI TIA/EIA-485 標準と電氣的に互換

2 アプリケーション

- ホストから電力を供給されるリモート・ステーションを使用したデータ転送
- 絶縁型マルチポイント・データ・バス
- 産業用プロセス制御ネットワーク
- 販売時点情報管理ネットワーク
- 電気料金のメーター

3 説明

SN65HVD08 は、平衡データ転送用に設計された 3 ステート差動ライン・ドライバと差動ライン・レシーバを組み合わせており、ANSI TIA/EIA-485-A および ISO-8482E 標準に準拠したデバイスとの相互運用が可能です。

SN65HVD08 は、幅広い電源電圧範囲と低静止時電流要件により、ケーブルの 5V 電源バスから最大 2V のライン電圧降下で動作します。ケーブルで電力を供給することにより、グラウンド絶縁バスの各接続で絶縁型電源を生成する必要が軽減されます。

ドライバ差動出力とレシーバ差動入力は内部で接続されており、差動入出力 (I/O) バス・ポートを形成しています。この設計により、ドライバが無効になったり、電力が供給されなくなっても、バスへの負荷が最小限になります。ドライバとレシーバはそれぞれアクティブ High、アクティブ Low のイネーブルを備えており、それらのイネーブルを外部で互いに接続することで、方向制御として機能させることができます。

パッケージ情報

部品番号	パッケージ ⁽¹⁾	本体サイズ (公称)
SN75HVD08、 SN65HVD08	SOIC (8)	4.90mm x 3.91mm
	PDIP (8)	9.81mm x 6.35mm

(1) 利用可能なパッケージについては、このデータシートの末尾にある注文情報を参照してください。

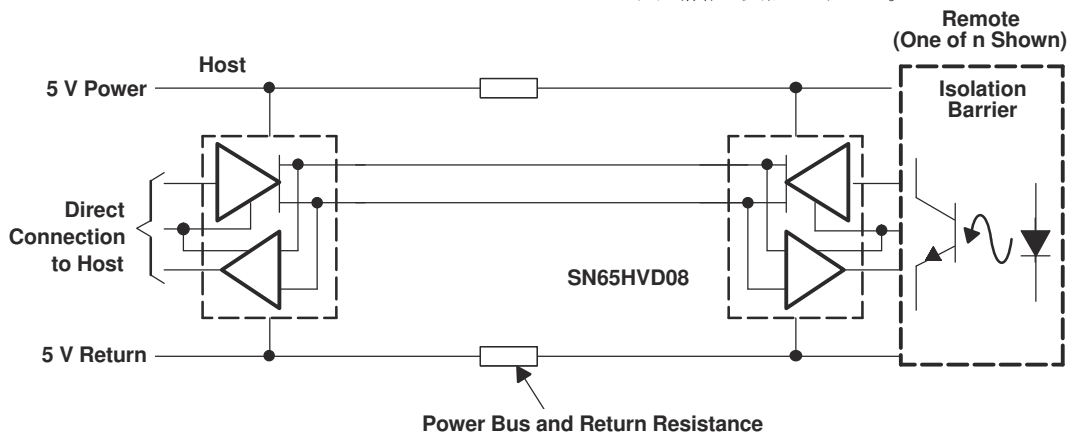

代表的なアプリケーション回路図



Table of Contents

1 特長.....	1	8.2 Functional Block Diagram.....	12
2 アプリケーション.....	1	8.3 Feature Description.....	12
3 説明.....	1	8.4 Device Functional Modes.....	12
4 Revision History.....	2	9 Application and Implementation.....	14
5 Pin Configuration and Functions.....	3	9.1 Application Information.....	14
6 Specifications.....	3	9.2 Typical Application.....	17
6.1 Absolute Maximum Ratings.....	3	9.3 Power Supply Recommendations.....	20
6.2 ESD Ratings.....	3	9.4 Layout.....	20
6.3 Recommended Operating Conditions.....	4	10 Device and Documentation Support.....	21
6.4 Thermal Information.....	4	10.1 Device Support.....	21
6.5 Electrical Characteristics.....	4	10.2 サポート・リソース.....	21
6.6 Driver Switching Characteristics.....	5	10.3 Trademarks.....	21
6.7 Receiver Switching Characteristics.....	5	10.4 静電気放電に関する注意事項.....	21
6.8 Typical Characteristics.....	7	10.5 用語集.....	21
7 Parameter Measurement Information.....	8	11 Mechanical, Packaging, and Orderable Information.....	21
8 Detailed Description.....	12		
8.1 Overview.....	12		

4 Revision History

Changes from Revision D (March 2015) to Revision E (February 2023)	Page
• Changed the <i>Thermal Information</i> table.....	4
• Changed the <i>Typical Characteristics</i>	7

Changes from Revision C (July 2006) to Revision D (March 2015)	Page
• 「ピン構成および機能」セクション、「ESD 定格」表、「機能説明」セクション、「デバイスの機能モード」セクション、「アプリケーションと実装」セクション、「電源に関する推奨事項」セクション、「レイアウト」セクション、「デバイスおよびドキュメントのサポート」セクション、「メカニカル、パッケージ、および注文情報」セクションを追加.....	1

5 Pin Configuration and Functions

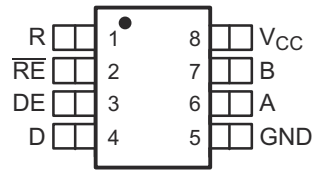

5-1. D or P Package, 8-Pin SOIC or PDIP (Top View)

表 5-1. Pin Functions

PIN		TYPE	DESCRIPTION
NAME	NO.		
A	6	Bus input / output	Driver output and receiver input (complementary to B)
B	7	Bus input / output	Driver output and receiver input (complementary to A)
D	4	Digital input	Driver data input
DE	3	Digital input	Driver enable high
GND	5	Reference potential	Local device ground
R	1	Digital output	Receive data output
RE	2	Digital input	Receiver enable low
V _{CC}	8	Supply	3-V to 5.5-V supply

6 Specifications

6.1 Absolute Maximum Ratings

over operating free-air temperature range unless otherwise noted^{(1) (2)}

	MIN	MAX	UNIT
Supply voltage, V _{CC}	-0.3	6	V
Voltage at A or B	-9	14	V
Input voltage at D, DE, R or RE	-0.5	V _{CC} + 0.5	V
Voltage input, transient pulse, A and B, through 100 Ω	-25	25	V
Receiver output current, I _O	-11	11	mA
Maximum Junction Temperature, T _J		150	°C
Storage Temperature, T _{STG}	-65	150	°C

- Stresses beyond those listed under *Absolute Maximum Ratings* may cause permanent damage to the device. These are stress ratings only, which do not imply functional operation of the device at these or any other conditions beyond those indicated under *Recommended Operating Conditions*. Exposure to absolute-maximum-rated conditions for extended periods may affect device reliability.
- All voltage values, except differential I/O bus voltages, are with respect to network ground terminal.

6.2 ESD Ratings

			VALUE	UNIT
V _(ESD) Electrostatic discharge	Human body model (HBM), per ANSI/ESDA/JEDEC JS-001 ⁽¹⁾	A, B, and GND	16000	V
		All pins	4000	
	Charged-device model (CDM), per JEDEC specification JESD22-C101 ⁽²⁾		1000	

- JEDEC document JEP155 states that 500-V HBM allows safe manufacturing with a standard ESD control process.
- JEDEC document JEP157 states that 250-V CDM allows safe manufacturing with a standard ESD control process.

6.3 Recommended Operating Conditions

		MIN	NOM	MAX	UNIT
Supply voltage, V_{CC}		3		5.5	V
Input voltage at any bus terminal (separately or common mode), V_i ⁽¹⁾		-7		12	V
High-level input voltage, V_{IH}	Driver, driver enable, and receiver enable inputs	2.25		V_{CC}	V
Low-level input voltage, V_{IL}		0		0.8	
Differential input voltage, V_{ID}		-12		12	
High-level output current, I_{OH}	Driver	-60			mA
	Receiver	-8			
Low-level output current, I_{OL}	Driver			60	mA
	Receiver			8	
Operating free-air temperature, T_A	SN75HVD08	0		70	°C
	SN65HVD08	-40		85	

(1) The algebraic convention, in which the least positive (most negative) limit is designated as minimum is used in this data sheet.

6.4 Thermal Information

THERMAL METRIC ⁽¹⁾		D (SOIC) SN75 Version	D (SOIC) SN65 Version	P (PDIP)	UNIT
		8 PINS	8 PINS	8 PINS	
$R_{\theta JA}$	Junction-to-ambient thermal resistance	175.4	116.7	125	°C/W
$R_{\theta JC(top)}$	Junction-to-case (top) thermal resistance	53.6	56.3	34.9	°C/W
$R_{\theta JB}$	Junction-to-board thermal resistance	45.1	63.4	23.7	°C/W
ψ_{JT}	Junction-to-top characterization parameter	10.1	8.8	12.1	°C/W
ψ_{JB}	Junction-to-board characterization parameter	44.4	62.6	23.6	°C/W

(1) For more information about traditional and new thermal metrics, see the *Semiconductor and IC Package Thermal Metrics* application report, [SPRA953](#).

6.5 Electrical Characteristics

over recommended operating conditions unless otherwise noted

PARAMETER		TEST CONDITIONS	MIN	TYP	MAX	UNIT
$ V_{OD} $	Driver differential output voltage magnitude	$R_L = 60 \Omega, 375 \Omega$ on each output to -7 V to 12 V, See 7-1	1.5		V_{CC}	V
$\Delta V_{OD} $	Change in magnitude of driver differential output voltage	$R_L = 54 \Omega$	-0.2		0.2	V
$V_{OC(PP)}$	Peak-to-peak driver common-mode output voltage	Center of two 27- Ω load resistors, See 7-2		0.5		V
V_{IT+}	Positive-going receiver differential input voltage threshold				-10	mV
V_{IT-}	Negative-going receiver differential input voltage threshold		-200			mV
V_{hys}	Receiver differential input voltage threshold hysteresis($V_{IT+} - V_{IT-}$)			35		mV
V_{OH}	Receiver high-level output voltage	$I_{OH} = -8$ mA	2.4			V
V_{OL}	Receiver low-level output voltage	$I_{OL} = 8$ mA			0.4	V
I_{IH}	Driver input, driver enable, and receiver enable high-level input current		-100		100	μ A
I_{IL}	Driver input, driver enable, and receiver enable low-level input current		-100		100	μ A
I_{OS}	Driver short-circuit output current	$7 V < V_O < 12 V$	-265		265	mA

6.5 Electrical Characteristics (continued)

over recommended operating conditions unless otherwise noted

PARAMETER		TEST CONDITIONS	MIN	TYP	MAX	UNIT
I _I	Bus input current (disabled driver)	V _I = 12 V			130	μA
		V _I = -7 V	-100			
		V _I = 12 V, V _{CC} = 0 V			130	
		V _I = -7 V, V _{CC} = 0 V	-100			
I _{CC}	Supply current	Receiver enabled, driver disabled, no load			10	mA
		Driver enabled, receiver disabled, no load			16	
		Both disabled			5	μA
		Both enabled, no load			16	mA

6.6 Driver Switching Characteristics

over recommended operating conditions unless otherwise noted

PARAMETER		TEST CONDITIONS	MIN	TYP	MAX	UNIT
t _{PHL}	Driver high-to-low propagation delay time	R _L = 54 Ω, C _L = 50 pF, See 7-3	18		40	ns
t _{PLH}	Driver low-to-high propagation delay time		18		40	
t _r	Driver 10%-to-90% differential output rise time		10		55	
t _f	Driver 90%-to-10% differential output fall time		10		55	
t _{SK(P)}	Driver differential output pulse skew, t _{PHL} - t _{PLH}				2.5	
t _{en}	Driver enable time	Receiver enabled, See Figures 4 and 5			55	ns
		Receiver disabled, See Figures 4 and 5			6	μs
t _{dis}	Driver disable time	Receiver enabled, See Figures 4 and 5			90	ns

6.7 Receiver Switching Characteristics

over recommended operating conditions unless otherwise noted

PARAMETER		TEST CONDITIONS	MIN	TYP	MAX	UNIT
t _{PHL}	Receiver high-to-low propagation delay time	C _L = 15 pF, See 7-6			70	ns
t _{PLH}	Receiver low-to-high propagation delay time				70	
t _r	Receiver 10%-to-90% differential output rise time				5	
t _f	Receiver 90%-to-10% differential output fall time				5	
t _{SK(P)}	Receiver differential output pulse skew, t _{PHL} - t _{PLH}				4.5	
t _{en}	Receiver enable time	Driver enabled, See 7-7			15	ns
		Driver disabled, See 7-8			6	μs
t _{dis}	Receiver disable time	Driver enabled, See 7-7			20	ns

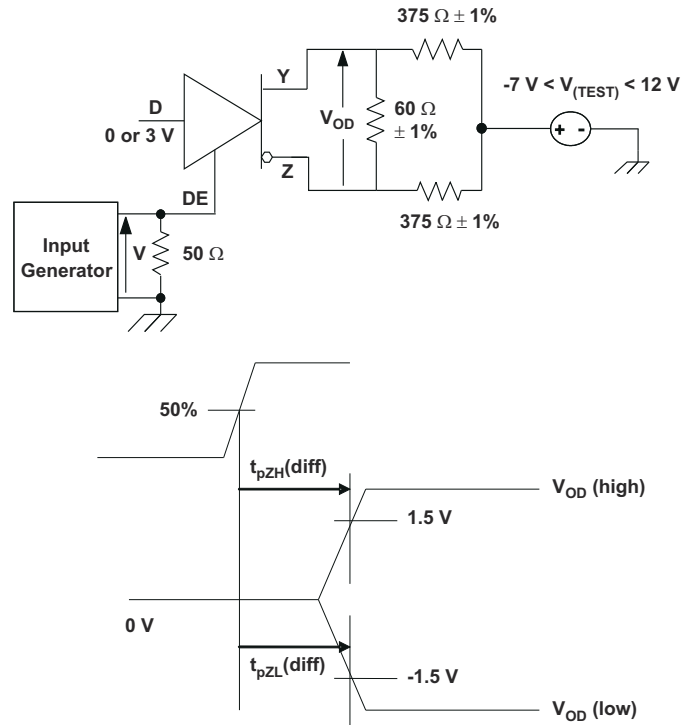

6-1. Driver Enable Time From DE to V_{OD}

The time $t_{pZL(x)}$ is the measure from DE to $V_{OD}(x)$. V_{OD} is valid when it is greater than 1.5 V.

6.8 Typical Characteristics

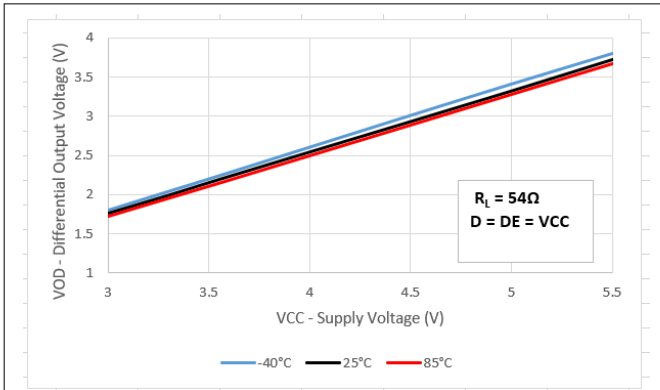

Fig 6-2. Differential Output Voltage vs Supply Voltage

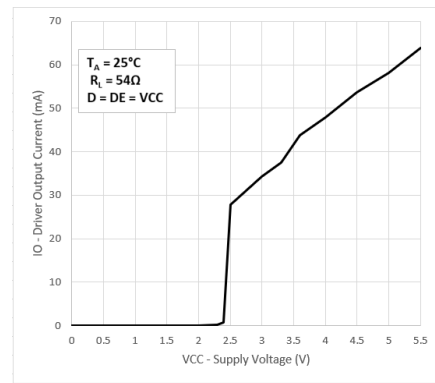

Fig 6-3. Driver Output Current vs Supply Voltage

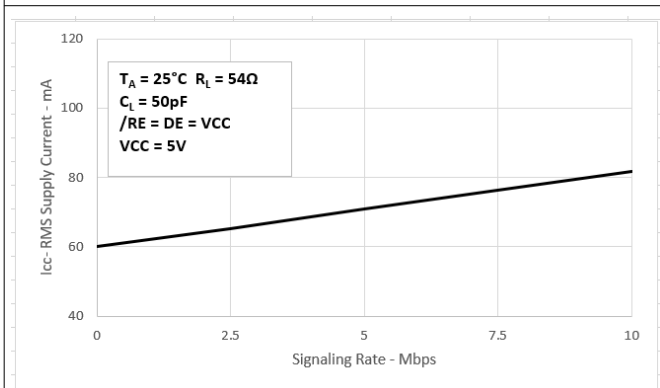

Fig 6-4. RMS Supply Current vs Signaling Rate

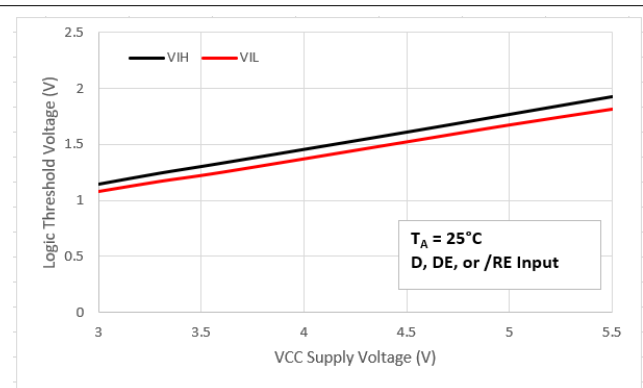

Fig 6-5. Logic Input Threshold Voltage vs Supply Voltage

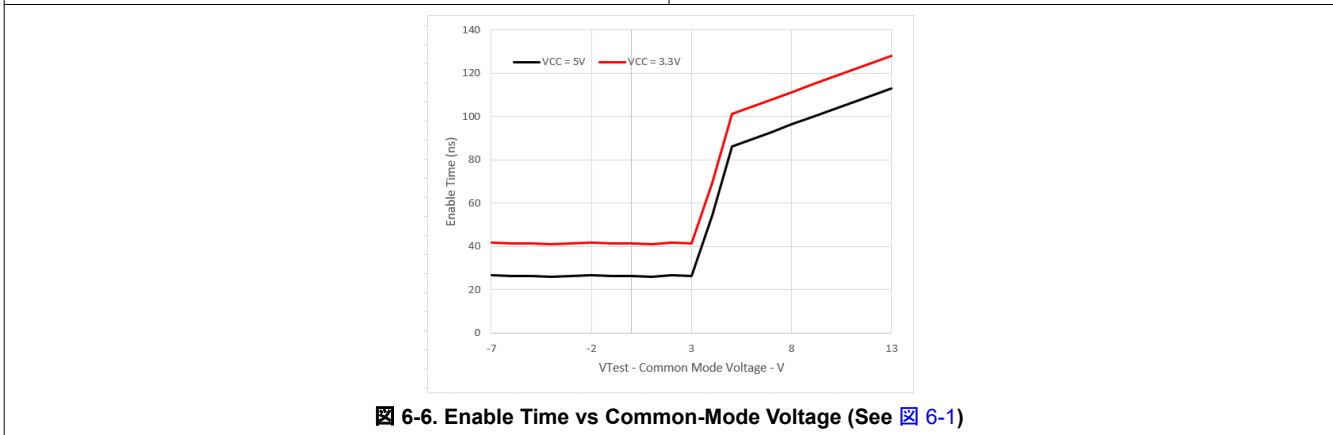
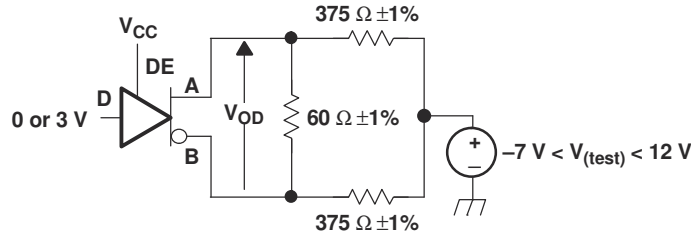
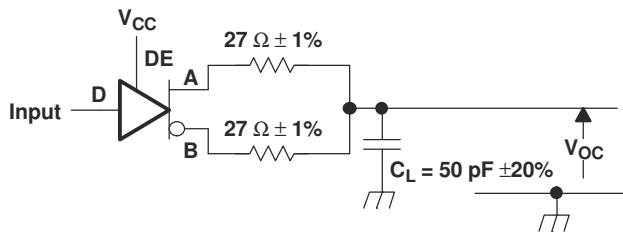

Fig 6-6. Enable Time vs Common-Mode Voltage (See Fig 6-1)

7 Parameter Measurement Information



7-1. Driver V_{OD} With Common-Mode Loading Test Circuit



C_L Includes Fixture and Instrumentation Capacitance

Input: PRR = 500 kHz, 50% Duty Cycle, $t_r < 6$ ns, $t_f < 6$ ns, $Z_o = 50 \Omega$

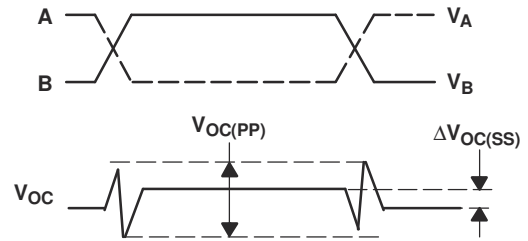

7-2. Test Circuit and Definitions for the Driver Common-Mode Output Voltage

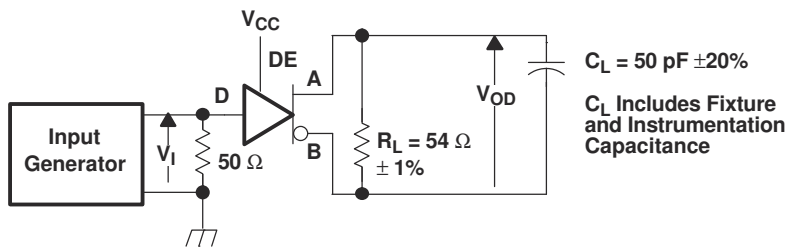

$C_L = 50 \text{ pF} \pm 20\%$
 C_L Includes Fixture and Instrumentation Capacitance

Generator: PRR = 500 kHz, 50% Duty Cycle, $t_r < 6$ ns, $t_f < 6$ ns, $Z_o = 50 \Omega$

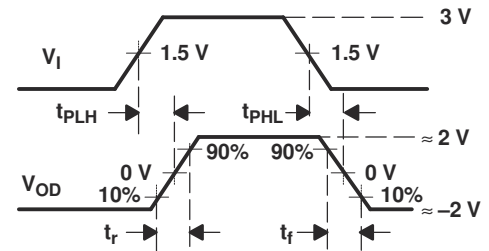

7-3. Driver Switching Test Circuit and Voltage Waveforms

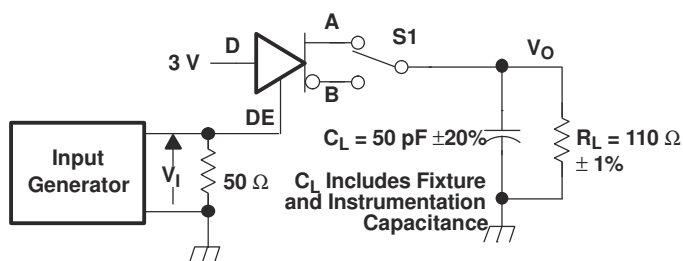

$C_L = 50 \text{ pF} \pm 20\%$
 C_L Includes Fixture and Instrumentation Capacitance

Generator: PRR = 500 kHz, 50% Duty Cycle, $t_r < 6$ ns, $t_f < 6$ ns, $Z_o = 50 \Omega$

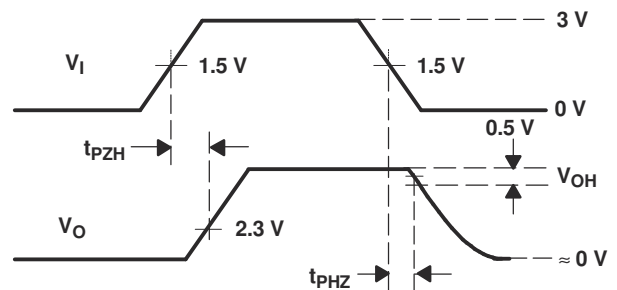

7-4. Driver High-Level Enable and Disable Time Test Circuit and Voltage Waveforms

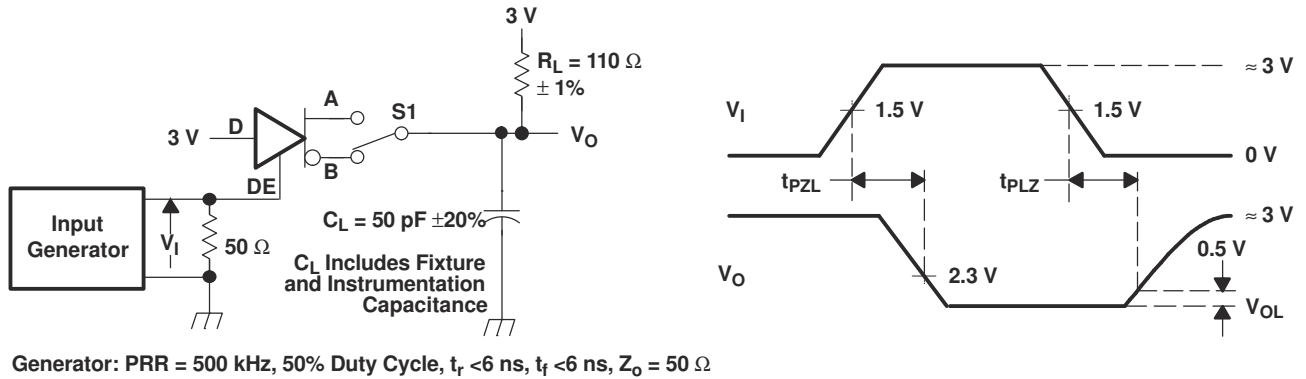

7-5. Driver Low-Level Output Enable and Disable Time Test Circuit and Voltage Waveforms

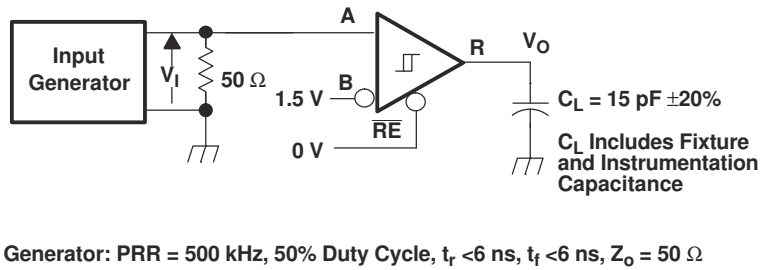

7-6. Receiver Switching Test Circuit and Voltage Waveforms

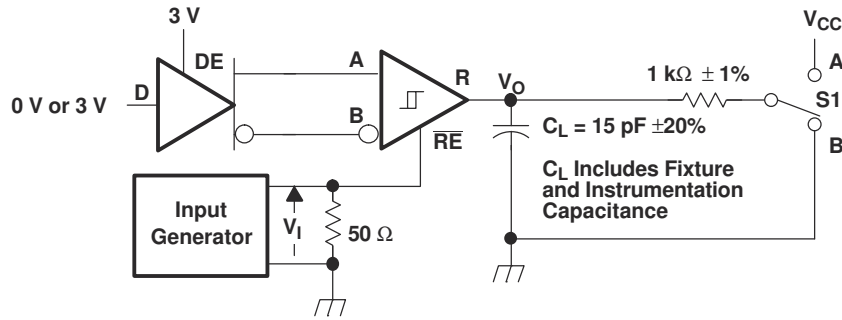

Generator: PRR = 500 kHz, 50% Duty Cycle, $t_r < 6$ ns, $t_f < 6$ ns, $Z_o = 50 \Omega$

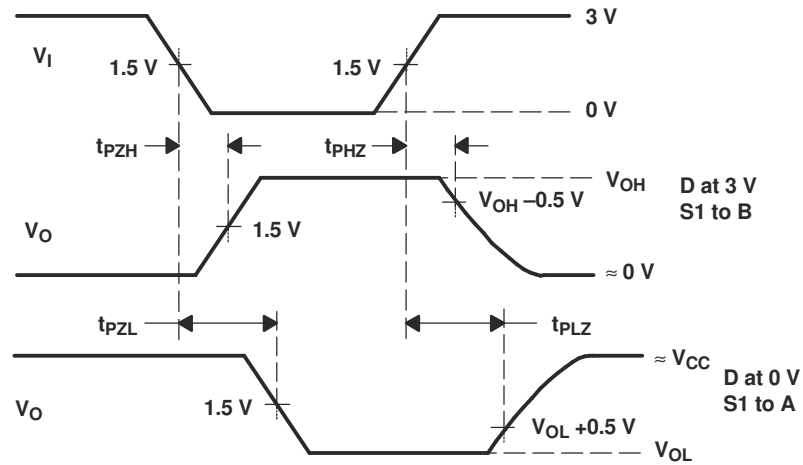

7-7. Receiver Enable and Disable Time Test Circuit and Voltage Waveforms With Drivers Enabled

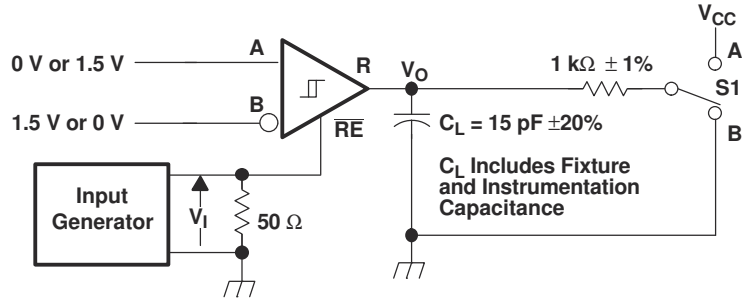

Generator: PRR = 100 kHz, 50% Duty Cycle, $t_r < 6$ ns, $t_f < 6$ ns, $Z_o = 50 \Omega$

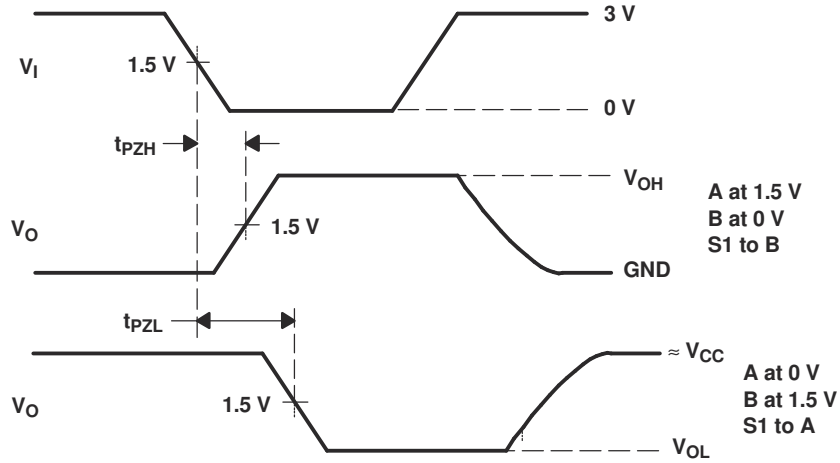

7-8. Receiver Enable Time From Standby (Driver Disabled)

8 Detailed Description

8.1 Overview

The SNx5HVD08 is a 3-V to 5.5-V, half-duplex, RS-485 transceiver suitable for data transmission up to 10 Mbps.

This device has an active-high driver enable and active-low receiver enable. A standby current of less than 5 μ A can be achieved by disabling both driver and receiver.

Device operation is specified over a wide temperature range from -40°C to +85°C.

8.2 Functional Block Diagram



图 8-1. Logic Diagram (Positive)

8.3 Feature Description

Internal ESD protection circuits protect the transceiver bus terminals against ± 16 kV Human Body Model (HBM) electrostatic discharges and all other pins up to ± 4 kV.

The SNx5HVD08 provides internal biasing of the receiver input thresholds for open-circuit, bus-idle, or short-circuit failsafe conditions, and a typical receiver hysteresis of 35 mV.

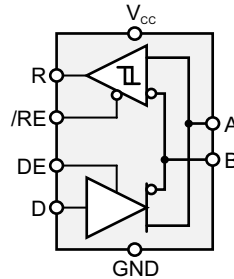
8.4 Device Functional Modes

表 8-1. Function Table:
Driver

INPUT	ENABLE	OUTPUTS	
D	DE	A	B
H	H	H	L
L	H	L	H
X	L	Z	Z
Open	H	H	L

表 8-2. Function Table: Receiver

DIFFERENTIAL INPUTS	ENABLE ⁽¹⁾	OUTPUT ⁽¹⁾
$V_{ID} = V_A - V_B$	RE	R
$V_{ID} \leq -0.2$ V	L	L
-0.2 V < $V_{ID} < -0.01$ V	L	?
-0.01 V $\leq V_{ID}$	L	H
X	H	Z
Open Circuit	L	H
Short Circuit	L	H

(1) H = high level; L = low level; Z = high impedance; X = irrelevant; ? = indeterminate

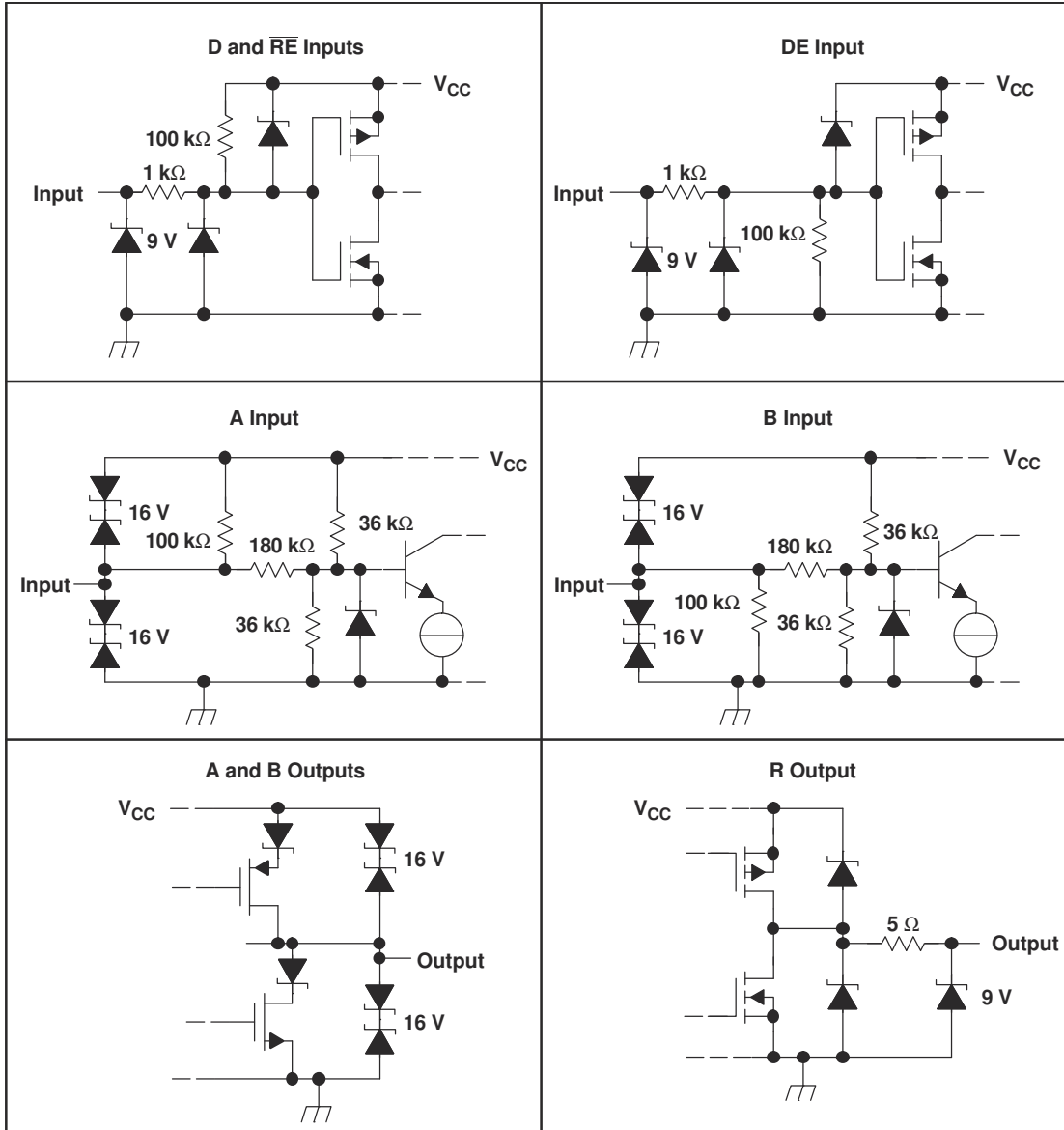

8-2. Equivalent Input and Output Schematic Diagrams

9 Application and Implementation

注

以下のアプリケーション情報は、TI の製品仕様に含まれるものではなく、TI ではその正確性または完全性を保証いたしません。個々の目的に対する製品の適合性については、お客様の責任で判断していただくこととなります。お客様は自身の設計実装を検証しテストすることで、システムの機能を確認する必要があります。

9.1 Application Information

As electrical loads are physically distanced from their power source, the effects of supply and return line impedance and the resultant voltage drop must be accounted. If the supply regulation at the load cannot be maintained to the circuit requirements, it forces the use of remote sensing, additional regulation at the load, bigger or shorter cables, or a combination of these. The SN65HVD08 eases this problem by relaxing the supply requirements to allow for more variation in the supply voltage over typical RS-485 transceivers.

9.1.1 Supply Source Impedance

In the steady state, the voltage drop from the source to the load is simply the wire resistance times the load current as modeled in [図 9-1](#).



図 9-1. Steady-State Circuit Model

For example, if you were to provide 5-V $\pm 5\%$ supply power to a remote circuit with a maximum load requirement of 0.1 A (one SN65HVD08), the voltage at the load would fall below the 4.5-V minimum of most 5-V circuits with as little as 5.8 m of 28-GA conductors. [表 9-1](#) summarizes wire resistance and the length for 4.5 V and 3 V at the load with 0.1 A of load current. The maximum lengths would scale linearly for higher or lower load currents.

表 9-1. Maximum Cable Lengths for Minimum Load Voltages at 0.1 A Load

WIRE SIZE	RESISTANCE	4.5-V LENGTH AT 0.1 A	3-V LENGTH AT 0.1 A
28 Gauge	0.213 Ω /m	5.8 m	41.1 m
24 Gauge	0.079 Ω /m	15.8 m	110.7 m
22 Gauge	0.054 Ω /m	23.1 m	162.0 m
20 Gauge	0.034 Ω /m	36.8 m	257.3 m
18 Gauge	0.021 Ω /m	59.5 m	416.7 m

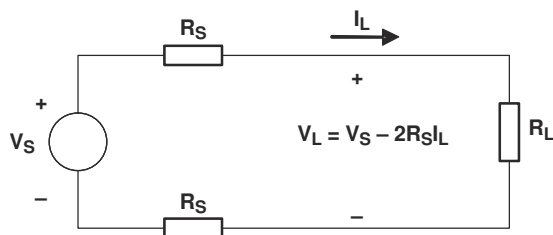
Under dynamic load requirements, the distributed inductance and capacitance of the power lines may not be ignored and decoupling capacitance at the load is required. The amount depends upon the magnitude and frequency of the load current change but, if only powering the SN65HVD08, a 0.1 μ F ceramic capacitor is usually sufficient.

9.1.2 Opto-Isolated Data Buses

Long RS-485 circuits can create large ground loops and pick up common-mode noise voltages in excess of the range tolerated by standard RS-485 circuits. A common remedy is to provide galvanic isolation of the data circuit from earth or local grounds.

Transformers, capacitors, or phototransistors most often provide isolation of the bus and the local node. Transformers and capacitors require changing signals to transfer the information over the isolation barrier and phototransistors (opto-isolators) can pass steady-state signals. Each of these methods incurs additional costs and complexity, the former in clock encoding and decoding of the data stream and the latter in requiring an isolated power supply.

Quite often, the cost of isolated power is repeated at each node connected to the bus as shown in [Figure 9-2](#). The possibly lower-cost solution is to generate this supply once within the system and then distribute it along with the data line(s) as shown in [Figure 9-3](#).

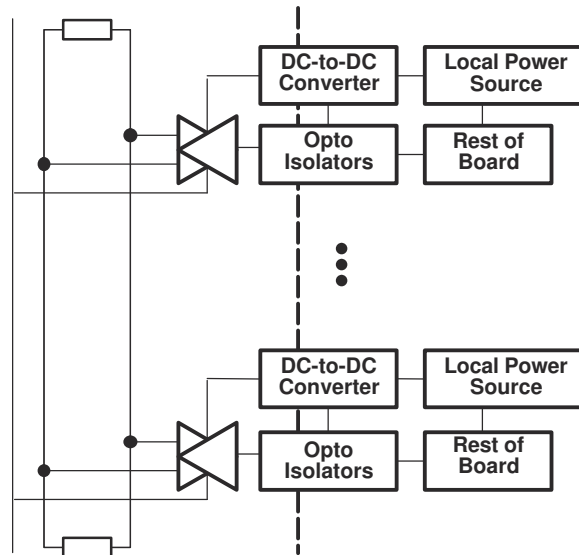

Figure 9-2. Isolated Power at Each Node

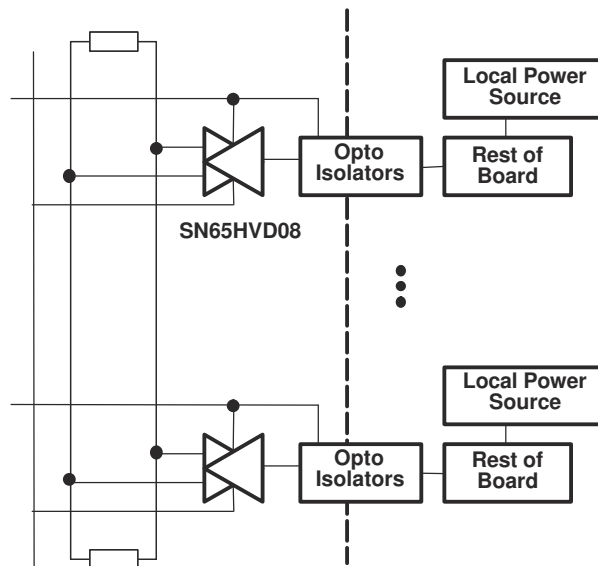

Figure 9-3. Distribution of Isolated Power

The features of the SN65HVD08 are particularly good for the application of [Figure 9-3](#). Due to added supply source impedance, the low quiescent current requirements and wide supply voltage tolerance allow for the poorer load regulation.

9.1.3 Opto Alternative

The ISO150 is a two-channel, galvanically isolated data coupler capable of data rates of 80 Mbps. Each channel can be individually programmed to transmit data in either direction.

Data is transmitted across the isolation barrier by coupling complementary pulses through high-voltage 0.4-pF capacitors. Receiver circuitry restores the pulses to standard logic levels. Differential signal transmission rejects isolation-mode voltage transients up to 1.6 kV/ms.

ISO150 avoids the problems commonly associated with opto-couplers. Optically-isolated couplers require high current pulses and allowance must be made for LED aging. The ISO150's Bi-CMOS circuitry operates at 25 mW per channel with supply voltage range matching that of the SN65HVD08 of 3 V to 5.5 V.

Figure 9-4 shows a typical circuit.

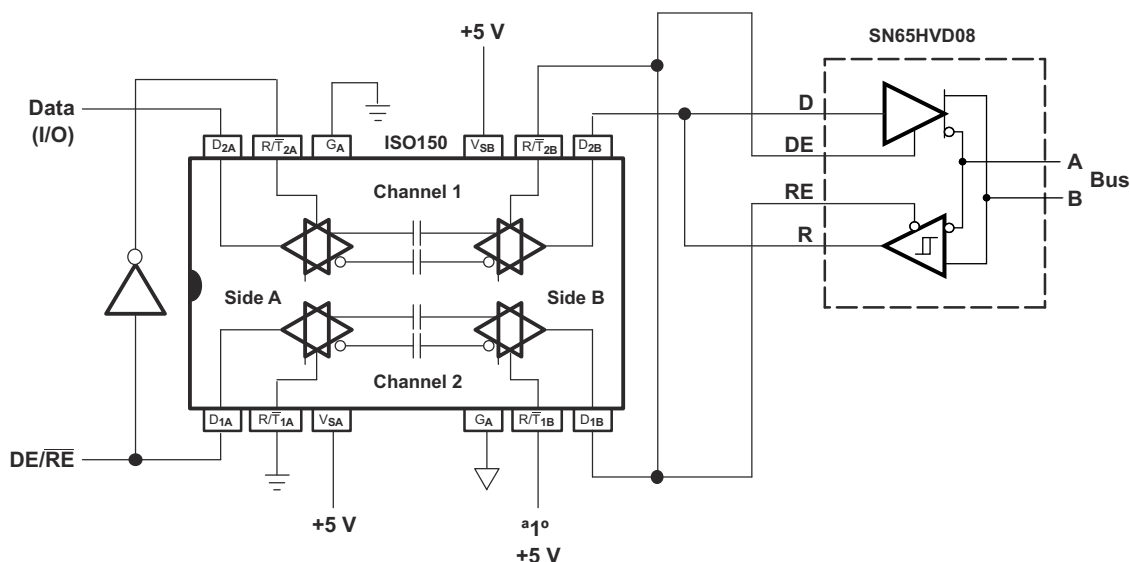
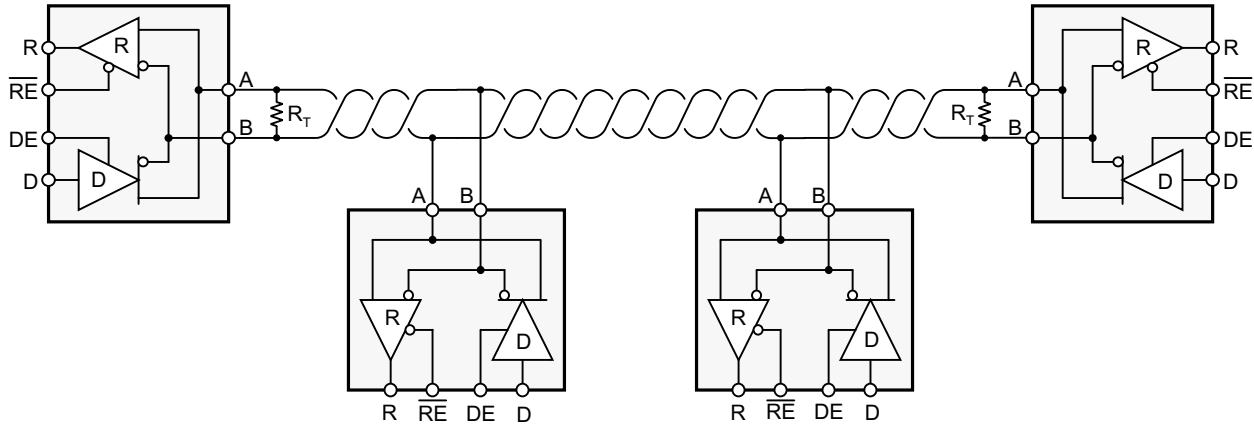

Figure 9-4. Isolated RS-485 Interface

9.2 Typical Application

An RS-485 bus consists of multiple transceivers connecting in parallel to a bus cable. To eliminate line reflections, each cable end is terminated with a termination resistor, R_T , whose value matches the characteristic impedance, Z_0 , of the cable. This method, known as parallel termination, allows for higher data rates over longer cable length.



9-5. Typical Application Diagram

9.2.1 Design Requirements

RS-485 is a robust electrical standard suitable for long-distance networking that may be used in a wide range of applications with varying requirements, such as distance, data rate, and number of nodes.

9.2.1.1 Data Rate and Bus Length

There is an inverse relationship between data rate and bus length, meaning the higher the data rate, the shorter the cable length; and conversely, the lower the data rate, the longer the cable may be without introducing data errors. While most RS-485 systems use data rates between 10 kbps and 100 kbps, some applications require data rates up to 250 kbps at distances of 4000 feet and longer. Longer distances are possible by allowing for small signal jitter of up to 5 or 10%.

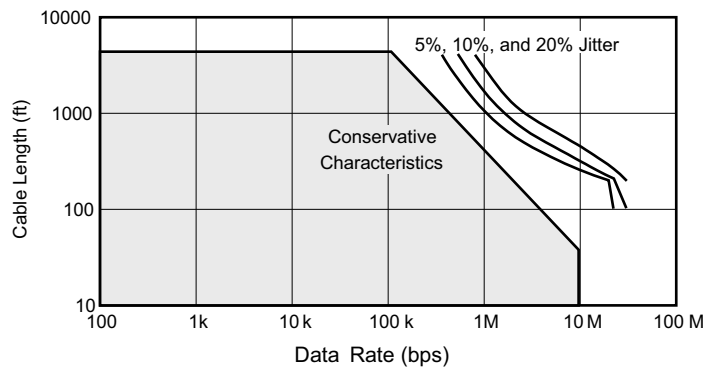

9-6. Cable Length vs Data Rate Characteristic

9.2.1.2 Stub Length

When connecting a node to the bus, the distance between the transceiver inputs and the cable trunk, known as the stub, should be as short as possible. Stubs present a non-terminated piece of bus line which can introduce reflections as the length of the stub increases. As a general guideline, the electrical length, or round-trip delay, of a stub should be less than one-tenth of the rise time of the driver, thus giving a maximum physical stub length as shown in 式 1.

$$L_{\text{stub}} \leq 0.1 \times t_r \times v \times c \quad (1)$$

Where:

- t_r is the 10/90 rise time of the driver
- c is the speed of light (3×10^8 m/s)
- v is the signal velocity of the cable or trace as a factor of c

Per 式 1, the maximum recommended stub length for the minimum driver output rise time of the SNx5HVD08 for a signal velocity of 78% is 0.23 meters (0.75 feet).

9.2.1.3 Bus Loading

The RS-485 standard specifies that a compliant driver must be able to driver 32 unit loads (UL), where 1 unit load represents a load impedance of approximately 12 k Ω . Because the SN65HVD08 and SN75HVD08 are each 1/8 UL transceivers, it is possible to connect up to 256 receivers to the bus.

9.2.1.4 Receiver Failsafe

The differential receivers of the SNx5HVD08 family are “failsafe” to invalid bus states caused by:

- Open bus conditions, such as a disconnected connector
- Shorted bus conditions, such as cable damage shorting the twisted-pair together
- Idle bus conditions that occur when no driver on the bus is actively driving

In any of these cases, the differential receiver will output a failsafe logic High state so that the output of the receiver is not indeterminate.

Receiver failsafe is accomplished by offsetting the receiver thresholds such that the “input indeterminate” range does not include zero volts differential.

In order to comply with the RS-422 and RS-485 standards, the receiver output must output a High when the differential input VID is more positive than +200 mV, and must output a Low when VID is more negative than -200 mV. The receiver parameters which determine the failsafe performance are VIT(+) and VIT(-).

As shown in the Electrical Characteristics table, differential signals more negative than -200 mV will always cause a Low receiver output, and differential signals more positive than -10 mV will always cause a High receiver output. Thus, when the differential input signal is close to zero, it is still above the maximum VIT(+) threshold of -10 mV, and the receiver output will be High.

9.2.2 Detailed Design Procedure

In order to protect bus nodes against high-energy transients, the implementation of external transient protection devices is necessary.



图 9-7. Transient protection against ESD, EFT, and Surge transients

图 9-7 suggests a protection circuit against 10 kV ESD (IEC 61000-4-2), 4 kV EFT (IEC 61000-4-4), and 1 kV surge (IEC 61000-4-5) transients. 表 9-2 shows the associated Bill of Materials.

表 9-2. Bill of Materials

DEVICE	FUNCTION	ORDER NUMBER	MANUFACTURER
XCVR	3.3 V to 5 V, 10 Mbps RS-485 Transceiver	SNx5HVD08	TI
R1, R2	10 Ω, Pulse-Proof Thick-Film Resistor	CRCW0603010RJNEAHP	Vishay
TVS	Bidirectional 400 W Transient Suppressor	CDSOT23-SM712	Bourns

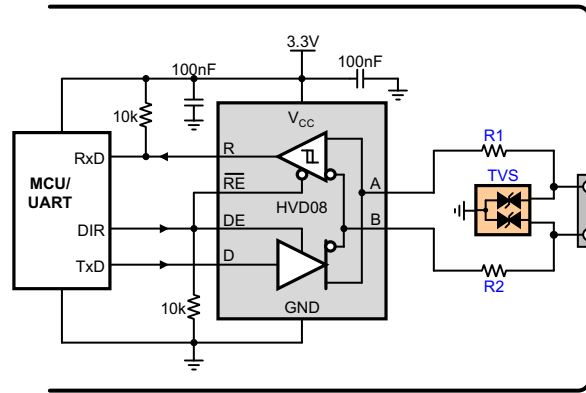
9.2.3 Application Curve

图 9-8 demonstrates operation of the SN65HVD08 at a signaling rate of 10 Mbps.



图 9-8. SNx5HVD08 Differential Output Waveform

9.3 Power Supply Recommendations

To ensure reliable operation at all data rates and supply voltages, each supply should be buffered with a 100-nF ceramic capacitor located as close to the supply pins as possible. The TPS76333 and TPS76350 are linear voltage regulators suitable for 3.3 V and 5 V supplies respectively.

9.4 Layout

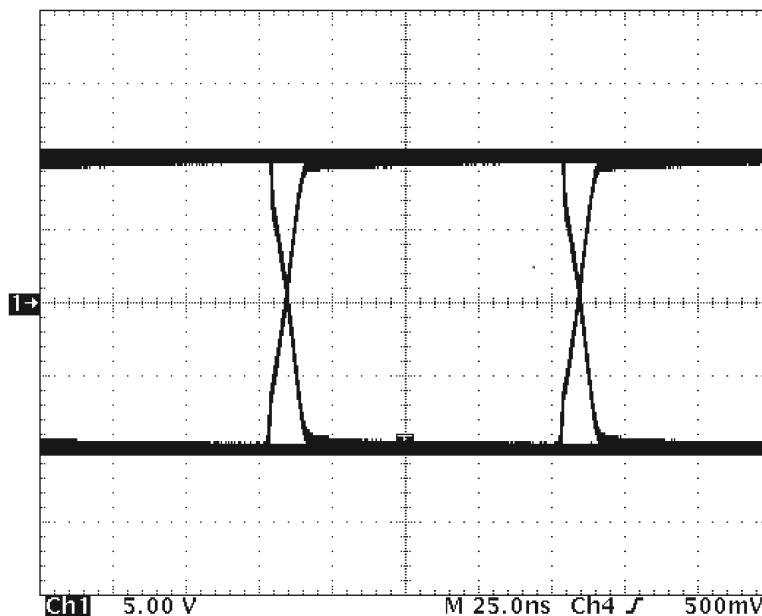
9.4.1 Layout Guidelines

On-chip IEC-ESD protection is sufficient for laboratory and portable equipment but insufficient for EFT and surge transients occurring in industrial environments. Therefore, robust and reliable bus node design requires the use of external transient protection devices.

Because ESD and EFT transients have a wide frequency bandwidth from approximately 3 MHz to 3 GHz, high frequency layout techniques must be applied during PCB design.

1. Place the protection circuitry close to the bus connector to prevent noise transients from entering the board.
2. Use VCC and ground planes to provide low-inductance. Note that high-frequency currents follow the path of least inductance and not the path of least impedance.
3. Design the protection components into the direction of the signal path. Do not force the transient currents to divert from the signal path to reach the protection device.
4. Apply 100-nF to 220-nF bypass capacitors as close as possible to the VCC-pins of transceiver, UART, or controller ICs on the board.
5. Use at least two vias for VCC and ground connections of bypass capacitors and protection devices to minimize effective via-inductance.
6. Use 1-k Ω to 10-k Ω pullup and pulldown resistors for enable lines to limit noise currents in these lines during transient events.
7. Insert series pulse-proof resistors into the A and B bus lines if the TVS clamping voltage is higher than the specified maximum voltage of the transceiver bus terminals. These resistors limit the residual clamping current into the transceiver and prevent it from latching up.
8. While pure TVS protection is sufficient for surge transients up to 1 kV, higher transients require metal-oxide varistors (MOVs) which reduce the transients to a few hundred volts of clamping voltage, and transient blocking units (TBUs) that limit transient current to less than 1 mA.

9.4.2 Layout Example

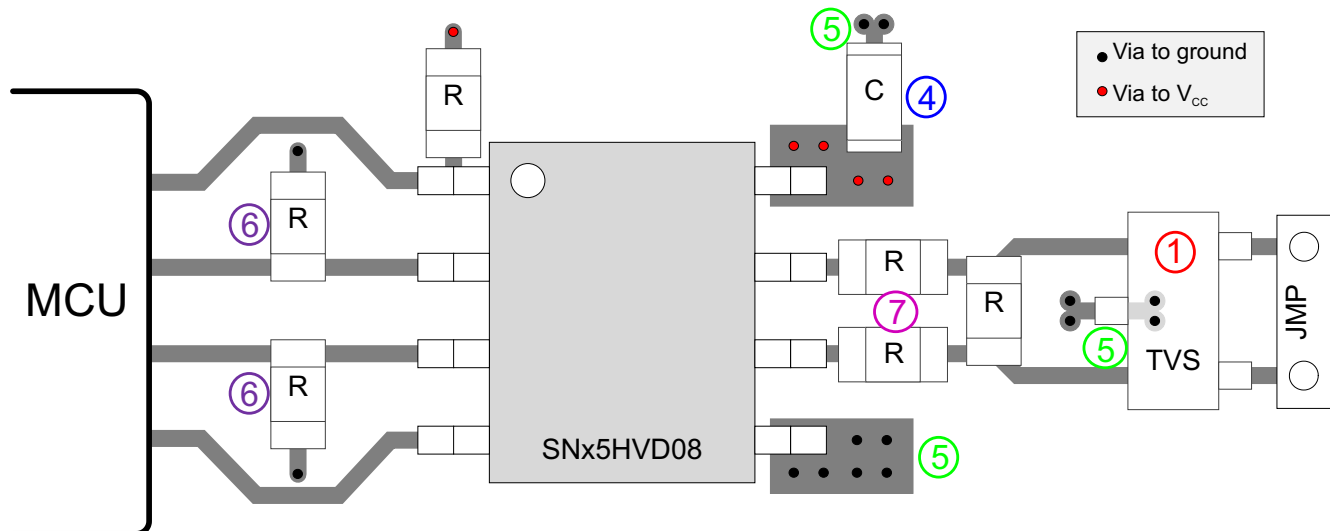

9-9. SNx5HVD08 Layout example

10 Device and Documentation Support

10.1 Device Support

10.1.1 サード・パーティ製品に関する免責事項

サード・パーティ製品またはサービスに関するテキサス・インスツルメンツの出版物は、単独またはテキサス・インスツルメンツの製品、サービスと一緒に提供される場合に関係なく、サード・パーティ製品またはサービスの適合性に関する是認、サード・パーティ製品またはサービスの是認の表明を意味するものではありません。

10.2 サポート・リソース

TI E2E™ サポート・フォーラムは、エンジニアが検証済みの回答と設計に関するヒントをエキスパートから迅速かつ直接得ることができる場所です。既存の回答を検索したり、独自の質問をしたりすることで、設計に必要な支援を迅速に得ることができます。

リンクされているコンテンツは、該当する貢献者により、現状のまま提供されるものです。これらは TI の仕様を構成するものではなく、必ずしも TI の見解を反映したものではありません。TI の [使用条件](#)を参照してください。

10.3 Trademarks

TI E2E™ is a trademark of Texas Instruments.

すべての商標は、それぞれの所有者に帰属します。

10.4 静電気放電に関する注意事項



この IC は、ESD によって破損する可能性があります。テキサス・インスツルメンツは、IC を取り扱う際には常に適切な注意を払うことを推奨します。正しい取り扱いおよび設置手順に従わない場合、デバイスを破損するおそれがあります。

ESD による破損は、わずかな性能低下からデバイスの完全な故障まで多岐にわたります。精密な IC の場合、パラメータがわずかに変化するだけで公表されている仕様から外れる可能性があるため、破損が発生しやすくなっています。

10.5 用語集

[テキサス・インスツルメンツ用語集](#) この用語集には、用語や略語の一覧および定義が記載されています。

11 Mechanical, Packaging, and Orderable Information

The following pages include mechanical, packaging, and orderable information. This information is the most current data available for the designated devices. This data is subject to change without notice and revision of this document. For browser-based versions of this data sheet, refer to the left-hand navigation.

PACKAGING INFORMATION

Orderable Device	Status (1)	Package Type	Package Drawing	Pins	Package Qty	Eco Plan (2)	Lead finish/ Ball material (6)	MSL Peak Temp (3)	Op Temp (°C)	Device Marking (4/5)	Samples
SN65HVD08D	OBSOLETE	SOIC	D	8		TBD	Call TI	Call TI	-40 to 85	VP08	
SN65HVD08DR	ACTIVE	SOIC	D	8	2500	RoHS & Green	NIPDAU	Level-1-260C-UNLIM	-40 to 85	VP08	Samples
SN65HVD08DRG4	ACTIVE	SOIC	D	8	2500	RoHS & Green	NIPDAU	Level-1-260C-UNLIM	-40 to 85	VP08	Samples
SN65HVD08P	ACTIVE	PDIP	P	8	50	RoHS & Green	NIPDAU	N / A for Pkg Type	-40 to 85	65HVD08	Samples
SN75HVD08D	OBSOLETE	SOIC	D	8		TBD	Call TI	Call TI	0 to 70	VN08	
SN75HVD08DR	OBSOLETE	SOIC	D	8		TBD	Call TI	Call TI	0 to 70	VN08	
SN75HVD08P	ACTIVE	PDIP	P	8	50	RoHS & Green	NIPDAU	N / A for Pkg Type	0 to 70	75HVD08	Samples

(1) The marketing status values are defined as follows:

ACTIVE: Product device recommended for new designs.

LIFEBUY: TI has announced that the device will be discontinued, and a lifetime-buy period is in effect.

NRND: Not recommended for new designs. Device is in production to support existing customers, but TI does not recommend using this part in a new design.

PREVIEW: Device has been announced but is not in production. Samples may or may not be available.

OBSOLETE: TI has discontinued the production of the device.

(2) **RoHS:** TI defines "RoHS" to mean semiconductor products that are compliant with the current EU RoHS requirements for all 10 RoHS substances, including the requirement that RoHS substance do not exceed 0.1% by weight in homogeneous materials. Where designed to be soldered at high temperatures, "RoHS" products are suitable for use in specified lead-free processes. TI may reference these types of products as "Pb-Free".

RoHS Exempt: TI defines "RoHS Exempt" to mean products that contain lead but are compliant with EU RoHS pursuant to a specific EU RoHS exemption.

Green: TI defines "Green" to mean the content of Chlorine (Cl) and Bromine (Br) based flame retardants meet JS709B low halogen requirements of <=1000ppm threshold. Antimony trioxide based flame retardants must also meet the <=1000ppm threshold requirement.

(3) MSL, Peak Temp. - The Moisture Sensitivity Level rating according to the JEDEC industry standard classifications, and peak solder temperature.

(4) There may be additional marking, which relates to the logo, the lot trace code information, or the environmental category on the device.

(5) Multiple Device Markings will be inside parentheses. Only one Device Marking contained in parentheses and separated by a "~" will appear on a device. If a line is indented then it is a continuation of the previous line and the two combined represent the entire Device Marking for that device.

(6) Lead finish/Ball material - Orderable Devices may have multiple material finish options. Finish options are separated by a vertical ruled line. Lead finish/Ball material values may wrap to two lines if the finish value exceeds the maximum column width.

Important Information and Disclaimer: The information provided on this page represents TI's knowledge and belief as of the date that it is provided. TI bases its knowledge and belief on information provided by third parties, and makes no representation or warranty as to the accuracy of such information. Efforts are underway to better integrate information from third parties. TI has taken and continues to take reasonable steps to provide representative and accurate information but may not have conducted destructive testing or chemical analysis on incoming materials and chemicals. TI and TI suppliers consider certain information to be proprietary, and thus CAS numbers and other limited information may not be available for release.

In no event shall TI's liability arising out of such information exceed the total purchase price of the TI part(s) at issue in this document sold by TI to Customer on an annual basis.

TAPE AND REEL INFORMATION

QUADRANT ASSIGNMENTS FOR PIN 1 ORIENTATION IN TAPE



*All dimensions are nominal

Device	Package Type	Package Drawing	Pins	SPQ	Reel Diameter (mm)	Reel Width W1 (mm)	A0 (mm)	B0 (mm)	K0 (mm)	P1 (mm)	W (mm)	Pin1 Quadrant
SN65HVD08DR	SOIC	D	8	2500	330.0	12.4	6.4	5.2	2.1	8.0	12.0	Q1

TAPE AND REEL BOX DIMENSIONS

*All dimensions are nominal

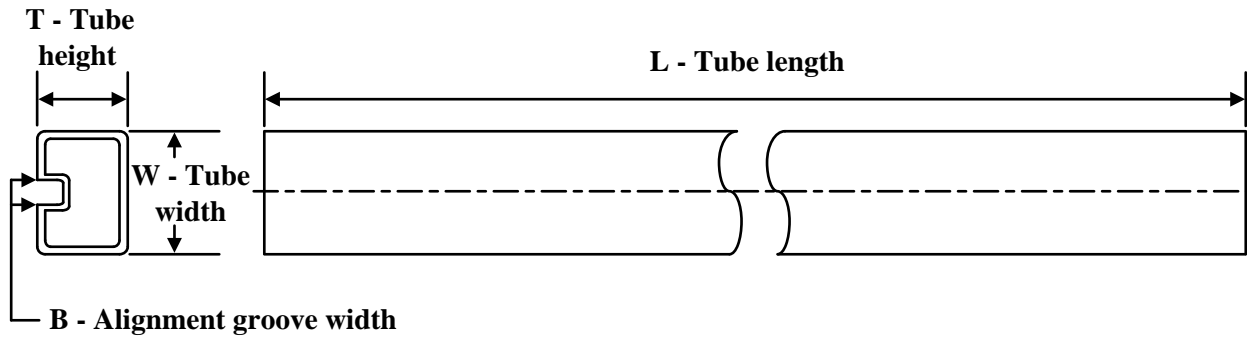
Device	Package Type	Package Drawing	Pins	SPQ	Length (mm)	Width (mm)	Height (mm)
SN65HVD08DR	SOIC	D	8	2500	356.0	356.0	35.0

TUBE

*All dimensions are nominal

Device	Package Name	Package Type	Pins	SPQ	L (mm)	W (mm)	T (μm)	B (mm)
SN65HVD08P	P	PDIP	8	50	506	13.97	11230	4.32
SN75HVD08P	P	PDIP	8	50	506	13.97	11230	4.32



D0008A

PACKAGE OUTLINE

SOIC - 1.75 mm max height

SMALL OUTLINE INTEGRATED CIRCUIT



4214825/C 02/2019

NOTES:

- Linear dimensions are in inches [millimeters]. Dimensions in parenthesis are for reference only. Controlling dimensions are in inches. Dimensioning and tolerancing per ASME Y14.5M.
- This drawing is subject to change without notice.
- This dimension does not include mold flash, protrusions, or gate burrs. Mold flash, protrusions, or gate burrs shall not exceed $.006$ [0.15] per side.
- This dimension does not include interlead flash.
- Reference JEDEC registration MS-012, variation AA.

EXAMPLE BOARD LAYOUT

D0008A

SOIC - 1.75 mm max height

SMALL OUTLINE INTEGRATED CIRCUIT



LAND PATTERN EXAMPLE
 EXPOSED METAL SHOWN
 SCALE:8X



SOLDER MASK DETAILS

4214825/C 02/2019

NOTES: (continued)

- 6. Publication IPC-7351 may have alternate designs.
- 7. Solder mask tolerances between and around signal pads can vary based on board fabrication site.

EXAMPLE STENCIL DESIGN

D0008A

SOIC - 1.75 mm max height

SMALL OUTLINE INTEGRATED CIRCUIT



SOLDER PASTE EXAMPLE
BASED ON .005 INCH [0.125 MM] THICK STENCIL
SCALE:8X

4214825/C 02/2019

NOTES: (continued)

8. Laser cutting apertures with trapezoidal walls and rounded corners may offer better paste release. IPC-7525 may have alternate design recommendations.
9. Board assembly site may have different recommendations for stencil design.

P (R-PDIP-T8)

PLASTIC DUAL-IN-LINE PACKAGE



- NOTES:
- A. All linear dimensions are in inches (millimeters).
 - B. This drawing is subject to change without notice.
 - C. Falls within JEDEC MS-001 variation BA.

重要なお知らせと免責事項

TI は、技術データと信頼性データ(データシートを含みます)、設計リソース(リファレンス・デザインを含みます)、アプリケーションや設計に関する各種アドバイス、Web ツール、安全性情報、その他のリソースを、欠陥が存在する可能性のある「現状のまま」提供しており、商品性および特定目的に対する適合性の黙示保証、第三者の知的財産権の非侵害保証を含むいかなる保証も、明示的または黙示的にかかわらず拒否します。

これらのリソースは、TI 製品を使用する設計の経験を積んだ開発者への提供を意図したものです。(1) お客様のアプリケーションに適した TI 製品の選定、(2) お客様のアプリケーションの設計、検証、試験、(3) お客様のアプリケーションに該当する各種規格や、その他のあらゆる安全性、セキュリティ、規制、または他の要件への確実な適合に関する責任を、お客様のみが単独で負うものとし、

上記の各種リソースは、予告なく変更される可能性があります。これらのリソースは、リソースで説明されている TI 製品を使用するアプリケーションの開発の目的でのみ、TI はその使用をお客様に許諾します。これらのリソースに関して、他の目的で複製することや掲載することは禁止されています。TI や第三者の知的財産権のライセンスが付与されている訳ではありません。お客様は、これらのリソースを自身で使用した結果発生するあらゆる申し立て、損害、費用、損失、責任について、TI およびその代理人を完全に補償するものとし、TI は一切の責任を拒否します。

TI の製品は、[TI の販売条件](#)、または [ti.com](#) やかかる TI 製品の関連資料などのいずれかを通じて提供する適用可能な条項の下で提供されています。TI がこれらのリソースを提供することは、適用される TI の保証または他の保証の放棄の拡大や変更を意味するものではありません。

お客様がいかなる追加条項または代替条項を提案した場合でも、TI はそれらに異議を唱え、拒否します。

郵送先住所 : Texas Instruments, Post Office Box 655303, Dallas, Texas 75265
Copyright © 2024, Texas Instruments Incorporated