

## 1.5A、24V、17MHz パワー オペアンプ

### 1 特長

- 車載アプリケーション用に AEC-Q100 認定済み:
  - 温度グレード 1: -40°C ~ +125°C, T<sub>A</sub>
- 大出力電流: 1.5A
- 広い電源電圧範囲:
  - シングル電源: 7V ~ 24V
  - デュアル電源: ±3.5V ~ ±12V
- 大きい出力スイング: 1.5A で 20V<sub>PP</sub>
- 包括的な保護機能
  - サーマル シャットダウン
  - 調整可能な電流制限
- 診断フラグ:
  - 過電流
  - サーマル シャットダウン
- 出力イネーブルおよび シャットダウン (E/S) 制御
- 高速:
  - ゲイン帯域幅積: 17MHz
  - フルパワー帯域幅 (10V<sub>PP</sub>): 1.3MHz
  - スルーレート: 40V/μs
- 接合部温度監視用ダイオード
- HSOIC-20 PowerPAD™ IC パッケージ

### 2 アプリケーション

- 電力線通信
- レゾルバドライバ
- バルブ、アクチュエータドライバ
- V<sub>COM</sub> ドライバ
- モータードライバ
- オーディオ パワー アンプ
- 電源出力アンプ
- 試験用機器アンプ
- レーザー ダイオードドライバ
- 汎用リニア電源ブースタ

### 3 概要

OPA564-Q1 は、誘導性負荷を最大 1.5A で駆動するのに最適な低コスト、大電流オペアンプです。また、高いスルーレートが、1.3MHz のフルパワー帯域幅と優れた直線性を提供しています。このモノリシック IC は、厳しい条件が要求される電力線通信、モーター制御アプリケーションで高い信頼性を実現します。

OPA564-Q1 は、単一 (7V ~ 24V) またはデュアル (±3.5V ~ ±12V) の電源で動作します。単一電源動作では、入力同相範囲が負側の電源にまで広がります。最大

出力電流のとき、公称 24V 電源で、出力信号の振幅は 20V<sub>PP</sub> (I<sub>OUT</sub> = 1.5A) まで拡張できます。

OPA564-Q1 は、過熱状態および電流過負荷に対する保護回路を内蔵しており、このデバイスには、ユーザーが選択できる高精度の電流制限機能があります。2 つのフラグ出力があり、1 つは電流制限を示し、もう 1 つは過熱状態を示します。また、このデバイスにはイネーブルおよびシャットダウン (E/S) ピンがあり、このピンを強制的に LOW にすることで出力をシャットダウンし、実質的に負荷を切断できます。

OPA564-Q1 は、熱的に強化された表面実装 PowerPAD IC パッケージ (HSOIC-20) で供給されます。

#### パッケージ情報

部品番号 (1)	パッケージ (2)	パッケージ サイズ (3)
OPA564-Q1	DWP (HSOIC, 20)	12.825mm × 10.405mm

- セクション 4 を参照してください。
- 詳細については、セクション 11 を参照してください。
- パッケージ サイズ (長さ × 幅) は公称値であり、該当する場合はピンも含まれます。

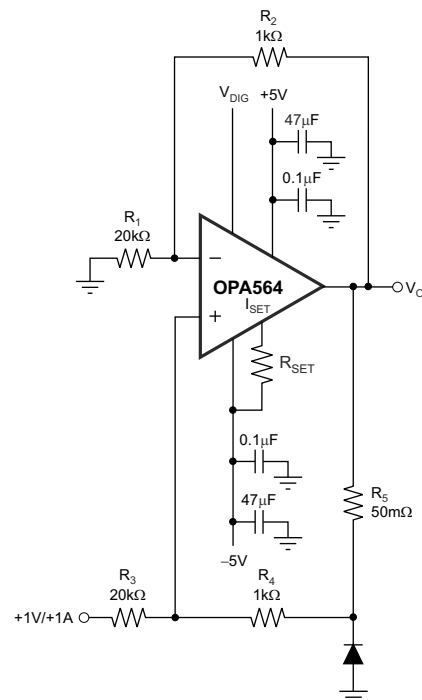

改良型ハウランド電流ポンプ



## Table of Contents

<b>1 特長</b> .....	1	7.4 Device Functional Modes.....	21
<b>2 アプリケーション</b> .....	1	<b>8 Application and Implementation</b> .....	22
<b>3 概要</b> .....	1	8.1 Application Information.....	22
<b>4 Device Comparison Table</b> .....	2	8.2 Typical Applications.....	25
<b>5 Pin Configuration and Functions</b> .....	3	8.3 Power Supply Recommendations.....	31
<b>6 Specifications</b> .....	4	8.4 Layout.....	32
6.1 Absolute Maximum Ratings <sup>(1)</sup> .....	4	<b>9 Device and Documentation Support</b> .....	34
6.2 ESD Ratings.....	4	9.1 ドキュメントの更新通知を受け取る方法.....	34
6.3 Recommended Operating Conditions.....	4	9.2 サポート・リソース.....	34
6.4 Thermal Information.....	5	9.3 Trademarks.....	34
6.5 Electrical Characteristics.....	5	9.4 静電気放電に関する注意事項.....	34
6.6 Typical Characteristics.....	7	9.5 用語集.....	34
<b>7 Detailed Description</b> .....	13	<b>10 Revision History</b> .....	34
7.1 Overview.....	13	<b>11 Mechanical, Packaging, and Orderable Information</b> .....	35
7.2 Functional Block Diagram.....	13		
7.3 Feature Description.....	13		

## 4 Device Comparison Table

DEVICE	DESCRIPTION
<a href="#">TMP141-Q1</a>	Automotive Grade, $\pm 1^{\circ}\text{C}$ Remote and Local Temperature Sensor With N-Factor and Series-R Correction
<a href="#">OPA333-Q1</a>	Automotive, microPower, 1.8V, 17 $\mu\text{A}$ Zero-Drift CMOS Precision Operational Amplifier
<a href="#">TLE427-Q1</a>	Automotive 450mA, Off-Battery (42V), Low-Dropout Voltage Regulator With RESET With Delay
<a href="#">OPA561</a>	Power Operational Amplifier, 1.2A, 15V, 17MHz, 50V/ $\mu\text{s}$

## 5 Pin Configuration and Functions

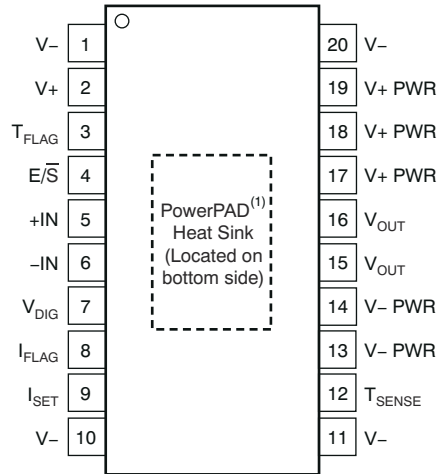

(1) PowerPAD is internally connected to V<sub>-</sub>. Soldering the PowerPAD to the PCB is always required, even with applications that have low power dissipation.

図 5-1. DWP Package, 20-Pin HSOIC (Top View)

表 5-1. Pin Functions

PIN		TYPE	DESCRIPTION
NAME	NO.		
E/S	4	Input	Enable/Shutdown output stage; take E/S low to shut down output
I <sub>FLAG</sub>	8	Output	Current limit flag; active high
I <sub>SET</sub>	9	Input	Current limit set (see <a href="#">セクション 8.1</a> )
-IN	6	Input	Inverting op amp input
+IN	5	Input	Noninverting op amp input
T <sub>FLAG</sub>	3	Output	Thermal overtemperature flag; flag is high when alarmed and device has gone into thermal shutdown
T <sub>SENSE</sub>	12	Input/Output	Temperature sense pin for use with a remote junction temperature sensor
V <sub>-</sub>	1, 10, 11, 20	Ground	-Supply for amplifier, PWR Out, and thermal pad
V <sub>-</sub> PWR	13, 14	Ground	-Supply for power output stage
V <sub>+</sub>	2	Power	+Supply for signal amplifier
V <sub>+</sub> PWR	17, 18, 19	Power	+Supply for power output stage
V <sub>DIG</sub>	7	Power	+Supply for digital flag and E/S (referenced to V <sub>-</sub> ). Valid range is (V <sub>-</sub> ) + 3.0V ≤ V <sub>DIG</sub> ≤ (V <sub>-</sub> ) + 5.5V.
V <sub>OUT</sub>	15, 16	Output	Output voltage; R <sub>O</sub> is high impedance when shut down
Pad	Thermal Pad	—	Thermal pad. Connect to V <sub>-</sub>

## 6 Specifications

### 6.1 Absolute Maximum Ratings<sup>(1)</sup>

Over operating free-air temperature range (unless otherwise noted).

		MIN	MAX	UNIT	
V <sub>S</sub>	Supply voltage, V <sub>S</sub> = (V+) – (V–)		26	V	
	Signal input pins	Voltage <sup>(2)</sup>	(V–) – 0.4	(V+) + 0.4	V
		Current through ESD diodes <sup>(2)</sup>		±10	mA
		Maximum differential voltage across inputs <sup>(3)</sup>		0.5	V
	Signal output pins	Voltage	(V–) – 0.4	(V+) + 0.4	V
		Current <sup>(4)</sup>		±10	mA
	Output short-circuit <sup>(5)</sup>		Continuous		
T <sub>J</sub>	Junction temperature		150	°C	
T <sub>stg</sub>	Storage temperature	–55	150	°C	
	Latch-up per JESD78B		Class 1 Level B		

- (1) Operation outside the *Absolute Maximum Ratings* may cause permanent device damage. *Absolute Maximum Ratings* do not imply functional operation of the device at these or any other conditions beyond those listed under *Recommended Operating Conditions*. If used outside the *Recommended Operating Conditions* but within the *Absolute Maximum Ratings*, the device may not be fully functional, and this may affect device reliability, functionality, performance, and shorten the device lifetime.
- (2) Input pins are diode-clamped to the power-supply rails. Current limit signals that can swing more than 0.4V beyond the supply rails to 10mA or less.
- (3) See [図 7-7](#) for information on input protection. See also [セクション 7.3.3](#).
- (4) Output pins are diode-clamped to the power-supply rails. Current limit input signals forcing the output pin more than 0.4V beyond the supply rails to 10mA or less.
- (5) Short-circuit to ground within SOA. See also [セクション 8.1.4](#).

### 6.2 ESD Ratings

			VALUE	UNIT
V <sub>(ESD)</sub>	Electrostatic discharge	Human body model (HBM), per AEC Q100-002 <sup>(1)</sup>	4000	V
		Charged device model (CDM), per AEC Q100-011	1000	
		Machine model (MM)	200	

- (1) AEC Q100-002 indicates HBM stressing is done in accordance with the ANSI/ESDA/JEDEC JS-001 specification.

### 6.3 Recommended Operating Conditions

over operating free-air temperature range (unless otherwise noted)

		MIN	NOM	MAX	UNIT
V <sub>S</sub>	Supply voltage <sup>(1)</sup>	7		24	V
V <sub>DIG</sub>	Digital supply voltage	(V–) + 3.0		(V–) + 5.5	V
T <sub>A</sub>	Operating ambient temperature <sup>(2)</sup>	–40		125	°C

- (1) Power-supply sequencing requirements must be observed; see also [セクション 8.3](#).
- (2) The OPA564-Q1 typically goes into thermal shutdown at a junction temperature greater than 140°C.

## 6.4 Thermal Information

THERMAL METRIC <sup>(1)</sup>		OPA564-Q1	UNIT
		DWP (HSOIC)	
		20 PINS	
R <sub>θJA</sub>	Junction-to-ambient thermal resistance	28.7	°C/W
R <sub>θJC(top)</sub>	Junction-to-case (top) thermal resistance	25.5	°C/W
R <sub>θJB</sub>	Junction-to-board thermal resistance	10.7	°C/W
ψ <sub>JT</sub>	Junction-to-top characterization parameter	3.9	°C/W
ψ <sub>JB</sub>	Junction-to-board characterization parameter	10.6	°C/W
R <sub>θJC(bot)</sub>	Junction-to-case (bottom) thermal resistance	2.5	°C/W

(1) For information about traditional and new thermal metrics, see the [Semiconductor and IC package thermal metrics](#) application report.

## 6.5 Electrical Characteristics

at T<sub>CASE</sub> = +25°C, V<sub>S</sub> = ±12V, R<sub>LOAD</sub> = 20kΩ to GND, R<sub>SET</sub> = 7.5kΩ, and E/√S pin enabled (unless otherwise noted)

PARAMETERS		TEST CONDITIONS	MIN	TYP	MAX	UNIT
<b>OFFSET VOLTAGE</b>						
V <sub>OS</sub>	Input offset voltage	V <sub>CM</sub> = 0V		±2	±20	mV
dV <sub>OS</sub> /dT	vs temperature	T <sub>A</sub> = -40°C to +125°C		±10		μV/°C
PSRR	vs power supply	V <sub>CM</sub> = 0V, V <sub>S</sub> = ±3.5V to ±13V		10	150	μV/V
<b>INPUT BIAS CURRENT</b>						
I <sub>B</sub>	Input bias current <sup>(1)</sup>	V <sub>CM</sub> = 0V		10	100	pA
	vs temperature	T <sub>A</sub> = -40°C to +125°C		See <a href="#">Fig 6-10</a>		
I <sub>OS</sub>	Input offset current <sup>(1)</sup>			10	100	pA
<b>NOISE</b>						
e <sub>n</sub>	Input voltage noise density	f = 1kHz		102.8		nV/√Hz
		f = 10kHz		20		nV/√Hz
		f = 100kHz		8		nV/√Hz
I <sub>n</sub>	Input current noise	f = 1kHz		4		fA/√Hz
<b>INPUT VOLTAGE RANGE</b>						
V <sub>CM</sub>	Common-mode voltage	Linear operation	(V-)		(V+) - 3	V
CMRR	Common-mode rejection ratio	V <sub>CM</sub> = (V-) to (V+) - 3V	70	80		dB
		V <sub>CM</sub> = (V-) to (V+) - 3V, T <sub>A</sub> = -40°C to +125°C		See <a href="#">Fig 6-9</a>		
<b>INPUT IMPEDANCE</b>						
	Input impedance	Differential		10 <sup>12</sup>    16		Ω    pF
		Common-mode		10 <sup>12</sup>    9		Ω    pF
<b>OPEN-LOOP GAIN</b>						
A <sub>OL</sub>	Open-loop voltage gain	V <sub>OUT</sub> = 20V <sub>PP</sub> , R <sub>LOAD</sub> = 1kΩ	80	108		dB
		V <sub>OUT</sub> = 20V <sub>PP</sub> , R <sub>LOAD</sub> = 10Ω		93		dB
<b>FREQUENCY RESPONSE</b>						
GBW	Gain-bandwidth product <sup>(1)</sup>	R <sub>LOAD</sub> = 5Ω		17		MHz
SR	Slew rate	G = 1, 10V step		40		V/μs
		Full power bandwidth	G = +2, V <sub>OUT</sub> = 10V <sub>PP</sub>		1.3	
	Settling time	G = +1, 10V step, C <sub>LOAD</sub> = 100pF	±0.1%	0.6		μs
			±0.01%	0.8		μs
THD+N	Total harmonic distortion + noise	f = 1kHz, R <sub>LOAD</sub> = 5Ω, G = +1, V <sub>OUT</sub> = 5V <sub>P</sub>		0.003		%

## 6.5 Electrical Characteristics (続き)

at  $T_{CASE} = +25^{\circ}C$ ,  $V_S = \pm 12V$ ,  $R_{LOAD} = 20k\Omega$  to GND,  $R_{SET} = 7.5k\Omega$ , and  $E/\bar{S}$  pin enabled (unless otherwise noted)

PARAMETERS		TEST CONDITIONS	MIN	TYP	MAX	UNIT
<b>OUTPUT</b>						
$V_{OUT}$	Voltage output	Positive	$I_{OUT} = 0.5A$	$(V+) - 1$	$(V+) - 0.4$	V
			$I_{OUT} = 1.5A$	$(V+) - 2$	$(V+) - 1.5$	V
		Negative	$I_{OUT} = -0.5A$	$(V-) + 1$	$(V-) + 0.3$	V
			$I_{OUT} = -1.5A$	$(V-) + 2$	$(V-) + 1.1$	V
$I_{OUT}$	Maximum continuous current, dc			1.5 <sup>(2)</sup>	A	
$R_O$	Output impedance, closed loop	$f = 100kHz$		10		$\Omega$
$Z_O$	Output impedance, open loop	$G = +2$ , $f = 100kHz$		See <a href="#">Figure 6-24</a>		
	Output current limit range <sup>(3)</sup>			$\pm 0.4$ to $\pm 1.9$		A
$I_{LIM}$	Current limit equation		$I_{LIM} \cong 20k \times \left[ \frac{1.2V}{5k\Omega + R_{SET}} \right]$ <sup>(4) (5)</sup>			A
		Solved for $R_{SET}$ (current limit)	$R_{SET} \cong (24k\Omega / I_{LIM}) - 5k\Omega$			$\Omega$
	Current limit accuracy	$I_{LIM} = 1.5A$		10		%
	Current limit overshoot <sup>(1) (6)</sup>	$V_{IN} = 5V$ pulse (200ns $t_r$ ), $G = +2$		50		%
	Output impedance <sup>(7)</sup>	Output shutdown		6    120		$G\Omega$    pF
$C_{LOAD}$	Capacitive load drive			See <a href="#">Figure 6-6</a>		
<b>DIGITAL CONTROL</b>						
	$V_{E/\bar{S}}$ high (output enabled)	$V_{DIG} = 3.3V$ to $5.5V$ referenced to $V-$	$E/\bar{S}$ pin open or forced high	$(V-) + 2$	$(V-) + V_{DIG}$	V
	$V_{E/\bar{S}}$ Low (output shut down)		$E/\bar{S}$ pin forced low	$(V-)$	$(V-) + 0.8$	V
	$I_{E/\bar{S}}$ high (output enabled)		$E/\bar{S}$ pin indicates high		10	$\mu A$
	$I_{E/\bar{S}}$ low (output shut down)		$E/\bar{S}$ pin indicates low		1	$\mu A$
	Output shutdown time			1		$\mu s$
	Output enable time			3		$\mu s$
	Current limit flag output	Normal operation, sinking $10\mu A$		$V-$	$(V-) + 0.8$	V
		Current-limited operation, sourcing $20\mu A$	$(V-) + 2$	$V_{DIG}$		V
<b>THERMAL SHUTDOWN</b>						
	Normal operation	Sinking $200\mu A$		$V-$	$(V-) + 0.8$	V
	Thermal shutdown <sup>(8)</sup>	Sourcing $200\mu A$	$(V-) + 2$	$V_{DIG}$		V
	Junction temperature at shutdown <sup>(9)</sup>			140 to 157		$^{\circ}C$
	Hysteresis <sup>(9)</sup>			15 to 19		$^{\circ}C$
<b>T<sub>SENSE</sub></b>						
$\eta$	Diode ideality factor			1.033		
<b>POWER SUPPLY<sup>(10)</sup></b>						
$I_Q$	Quiescent current <sup>(4)</sup>	$I_{OUT} = 0A$		39	50	mA
		$I_{OUT} = 0A$ , $T_A = -40^{\circ}C$ to $125^{\circ}C$			50	mA
$I_{QSD}$	Quiescent current in shutdown mode				5	mA
$I_{DIG}$	Digital quiescent current	$V_{DIG} = 5V$		43	100	$\mu A$

(1) See [セクション 6.6](#).

(2) Under safe operating conditions; see also [セクション 8.1.4](#).

(3) Minimum current limit is 0.4A; see also [セクション 7.3.1](#).

(4) Quiescent current increases when the current limit is increased (see also [Figure 6-33](#)).

(5)  $R_{SET}$  (current limit) ranges from  $55k\Omega$  ( $I_{OUT} = 400mA$ ) to  $10k\Omega$  ( $I_{OUT} = 1.6A$  typical); see also [セクション 7.3.1](#).

(6) Transient load transition time must be  $\geq 200ns$ .

(7) See also [セクション 7.3.2](#).

(8) When sourcing, the  $V_{DIG}$  supply must be able to supply the current.

(9) Characterized, but not production tested.

(10) Power-supply sequencing requirements must be observed. See [セクション 8.3](#) for more information.

## 6.6 Typical Characteristics

at  $T_{CASE} = 25^{\circ}C$ ,  $V_S = \pm 12V$ ,  $R_{LOAD} = 20k\Omega$  to GND,  $R_{SET} = 7.5k\Omega$ , and  $E/\bar{S}$  pin enabled (unless otherwise noted)

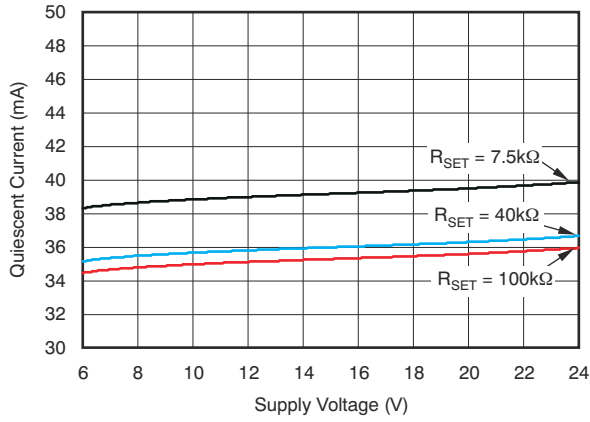

6-1. Quiescent Current vs Supply Voltage

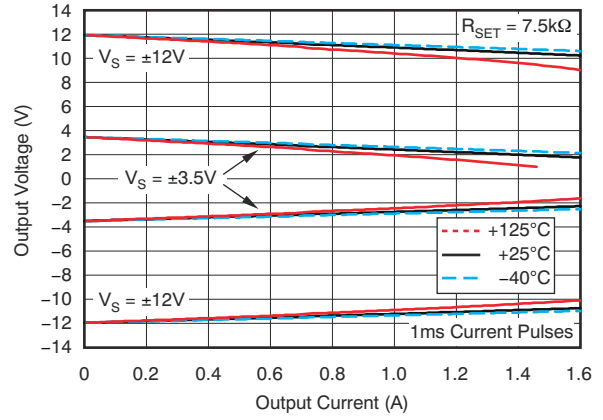

6-2. Output Voltage Swing vs Output Current

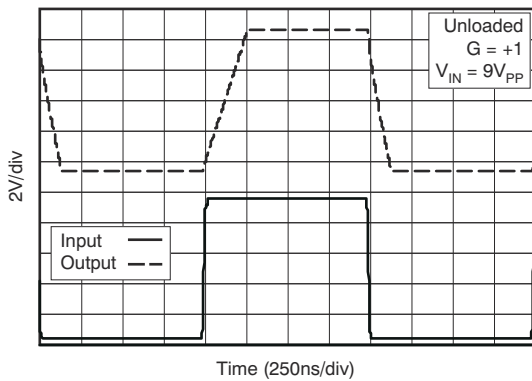

No load

6-3. Large-Signal Step Response

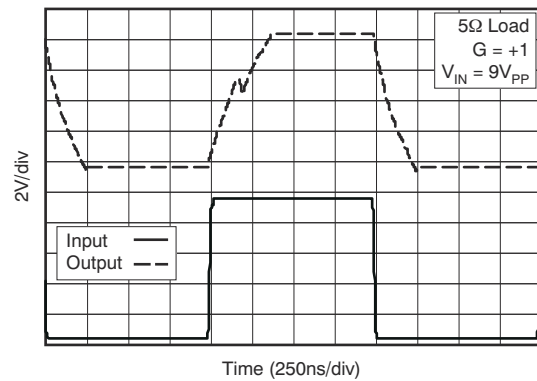

6-4. Large-Signal Step Response

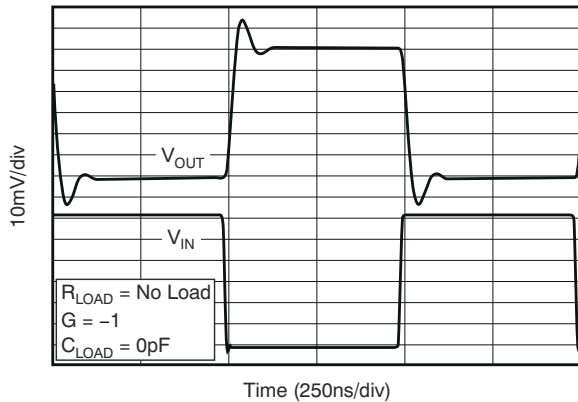

6-5. Small-Signal Step Response

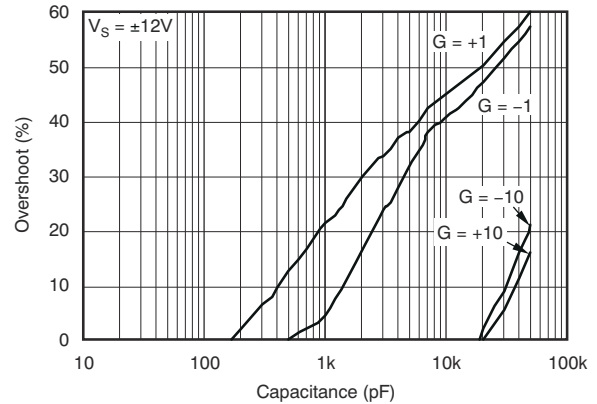

6-6. Small-Signal Overshoot vs Load Capacitance

### 6.6 Typical Characteristics (continued)

at  $T_{CASE} = 25^{\circ}C$ ,  $V_S = \pm 12V$ ,  $R_{LOAD} = 20k\Omega$  to GND,  $R_{SET} = 7.5k\Omega$ , and  $E/\bar{S}$  pin enabled (unless otherwise noted)



图 6-7.  $I_Q$  vs Temperature



图 6-8. Offset Voltage vs Temperature

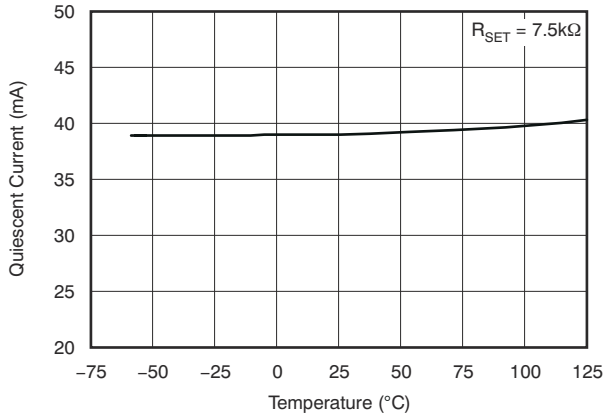

图 6-9.  $A_{OL}$ , PSRR, and CMRR vs Temperature

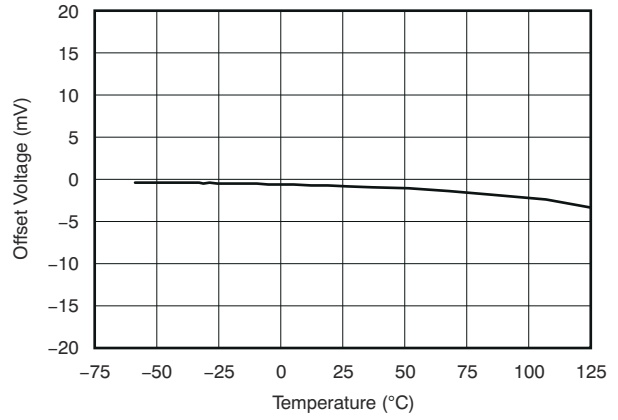

图 6-10.  $I_B$  vs Temperature

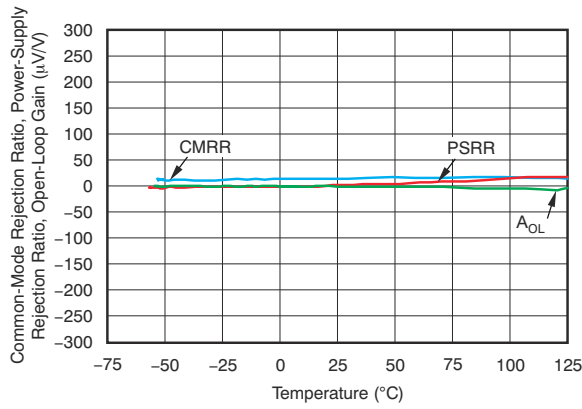

图 6-11.  $I_Q$ , Shutdown vs Temperature

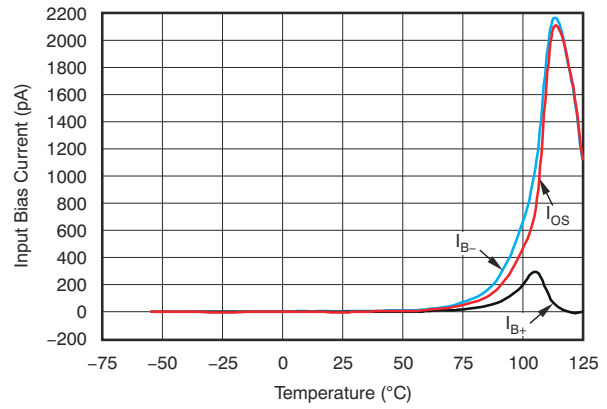

图 6-12.  $I_{DIG}$  vs Temperature

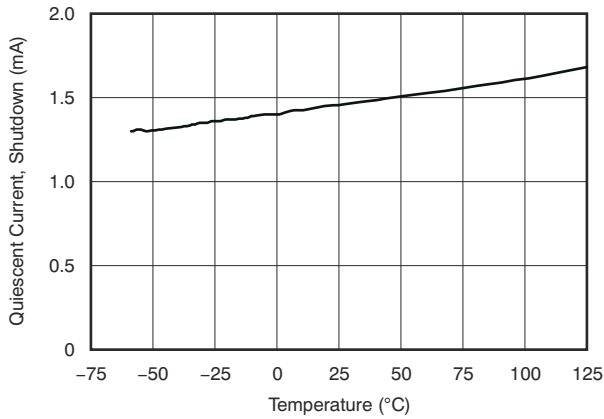

## 6.6 Typical Characteristics (continued)

at  $T_{CASE} = 25^{\circ}C$ ,  $V_S = \pm 12V$ ,  $R_{LOAD} = 20k\Omega$  to GND,  $R_{SET} = 7.5k\Omega$ , and  $E/\bar{S}$  pin enabled (unless otherwise noted)

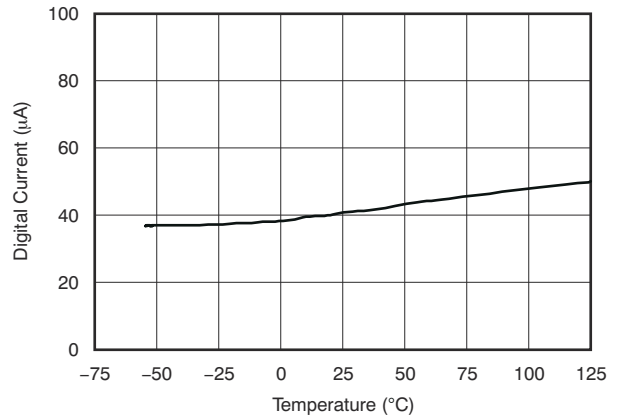
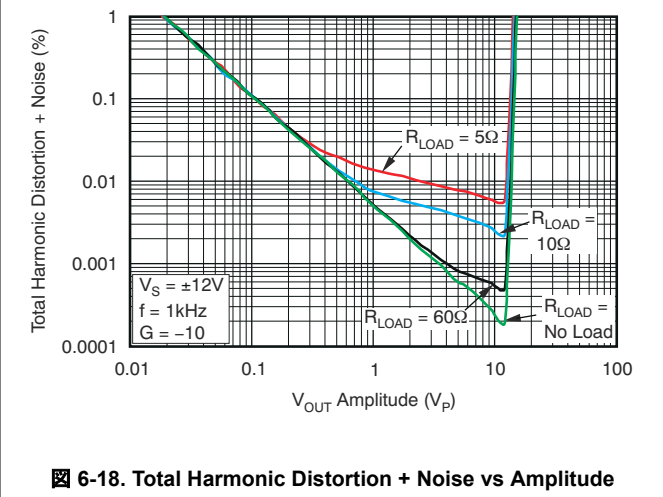
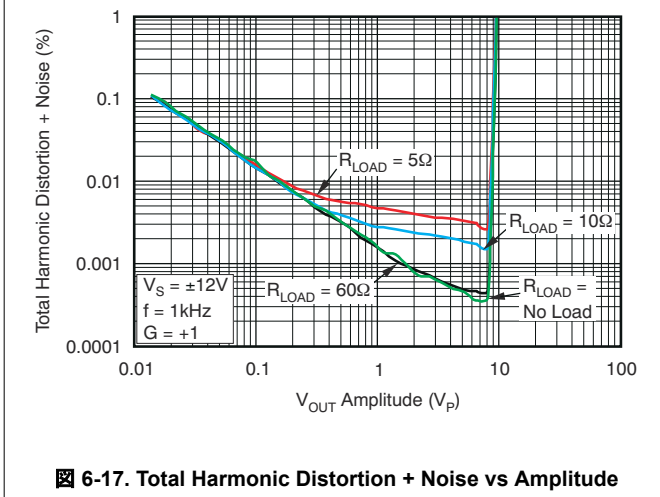
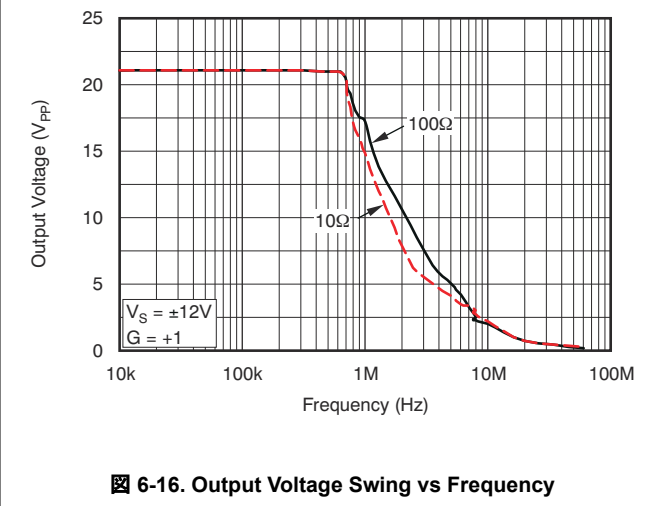
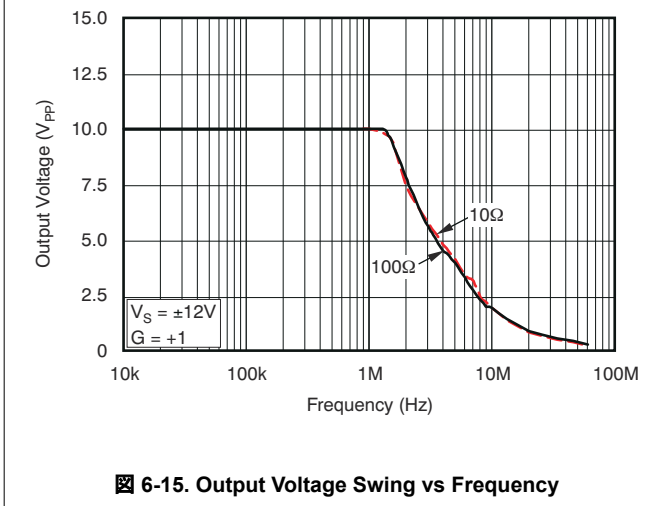
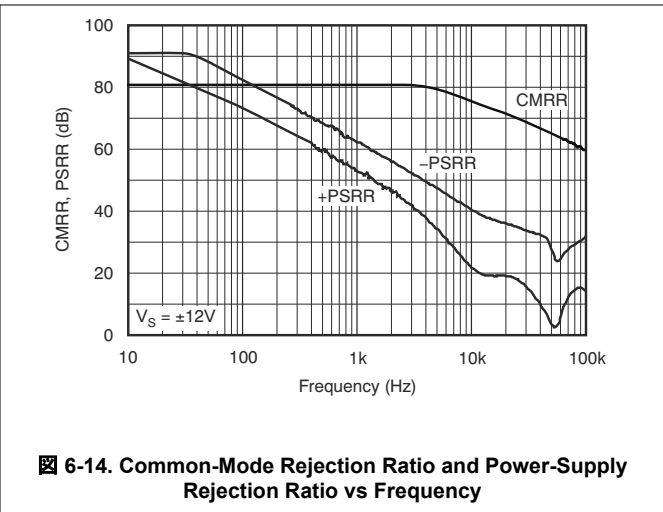
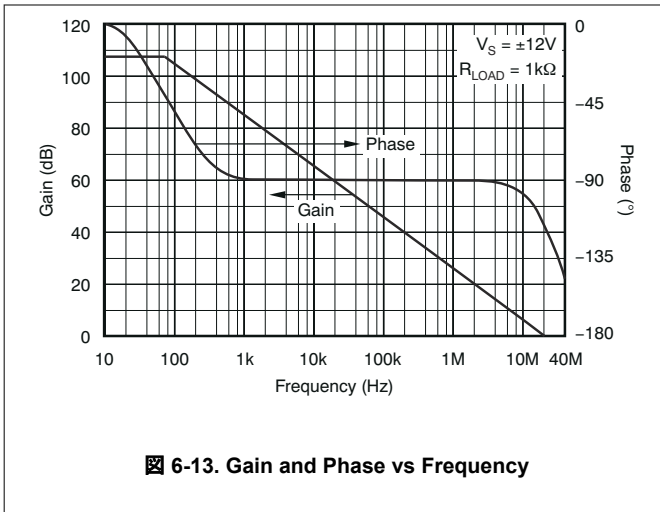

### 6.6 Typical Characteristics (continued)

at  $T_{CASE} = 25^{\circ}C$ ,  $V_S = \pm 12V$ ,  $R_{LOAD} = 20k\Omega$  to GND,  $R_{SET} = 7.5k\Omega$ , and  $E/\bar{S}$  pin enabled (unless otherwise noted)

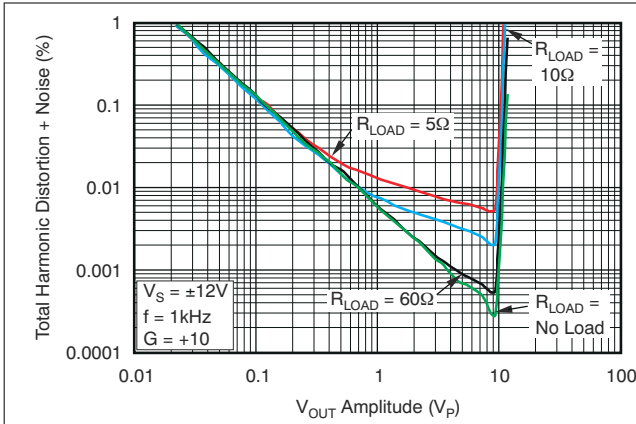

Figure 6-19. Total Harmonic Distortion + Noise vs Amplitude

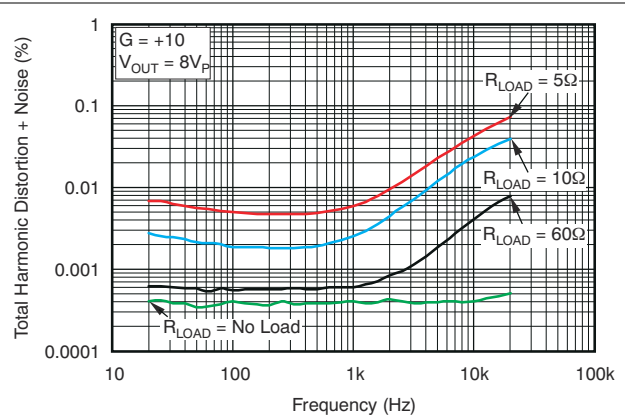

Figure 6-20. Total Harmonic Distortion + Noise vs Frequency

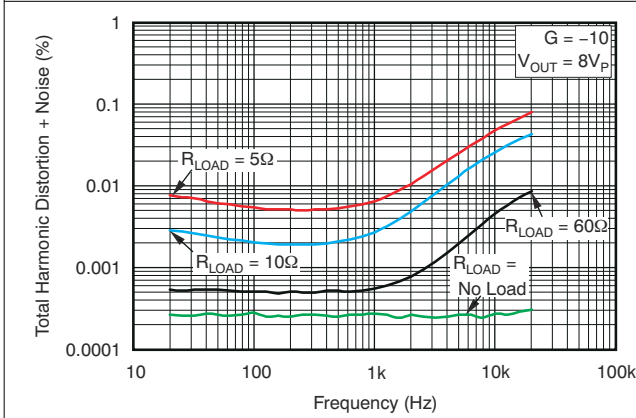

Figure 6-21. Total Harmonic Distortion + Noise vs Frequency

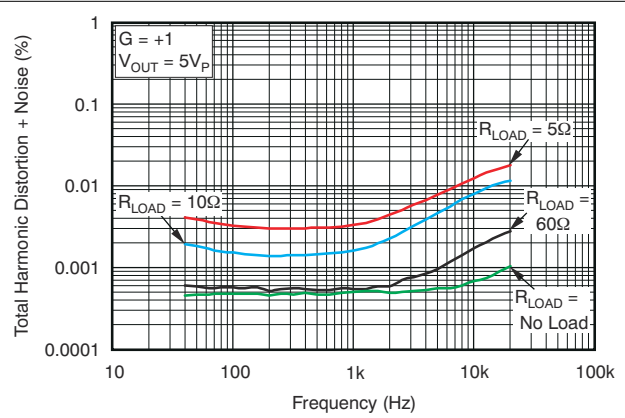

Figure 6-22. Total Harmonic Distortion + Noise vs Frequency

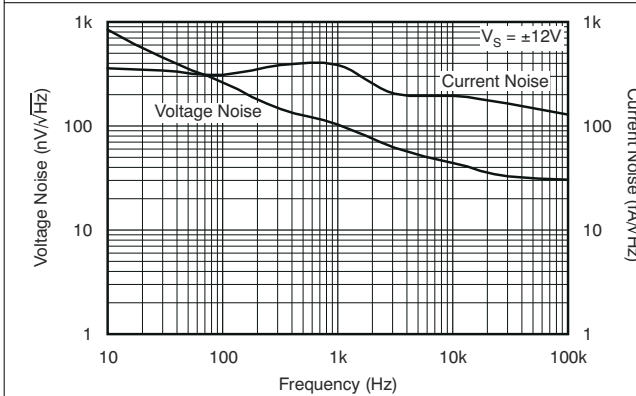

Figure 6-23. Input Voltage Spectral Noise and Current Noise vs Frequency

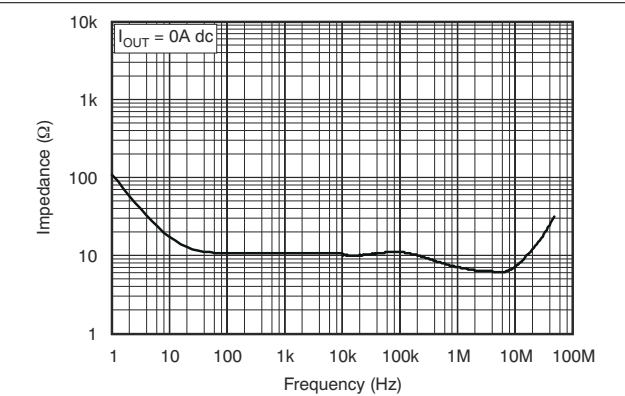
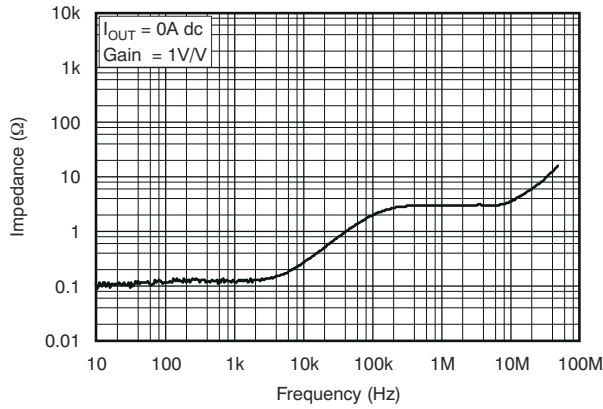

Figure 6-24. Open-Loop Output Impedance

## 6.6 Typical Characteristics (continued)

at  $T_{CASE} = 25^{\circ}C$ ,  $V_S = \pm 12V$ ,  $R_{LOAD} = 20k\Omega$  to GND,  $R_{SET} = 7.5k\Omega$ , and  $E/\bar{S}$  pin enabled (unless otherwise noted)



No load

Figure 6-25. Closed-Loop Output Impedance

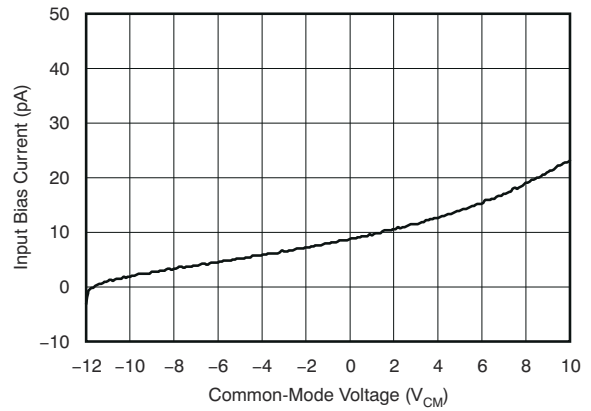
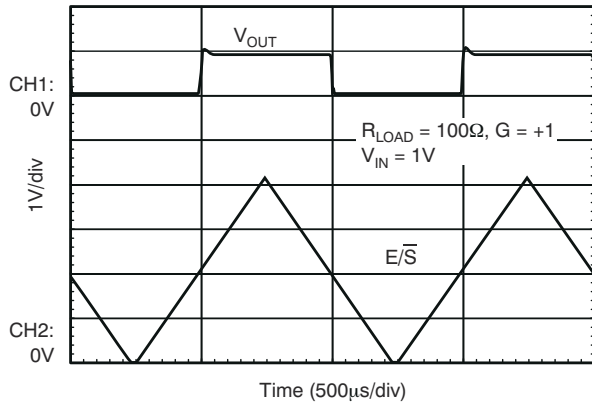

Figure 6-26. Input Bias Current vs Common-Mode Voltage



$R_{LOAD} = 100\Omega$

Figure 6-27. Enable Response

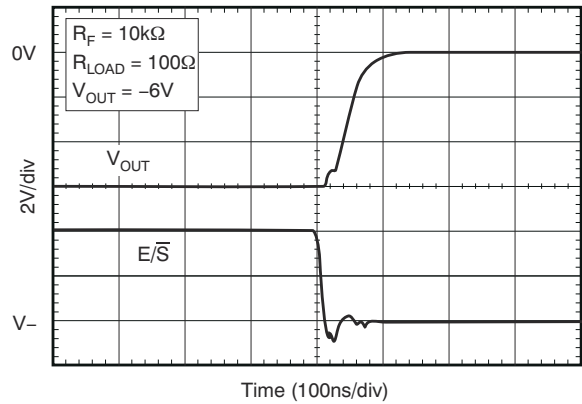

Figure 6-28. Shutdown Time (Inverting Configuration)

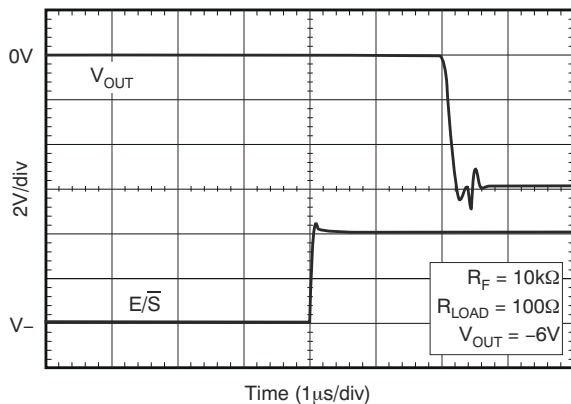

Figure 6-29. Enable Time (Inverting Configuration)

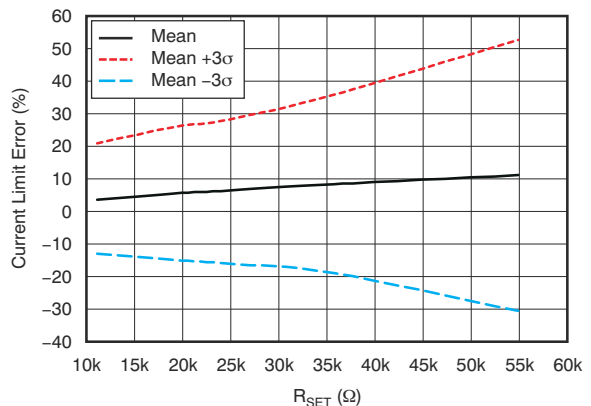
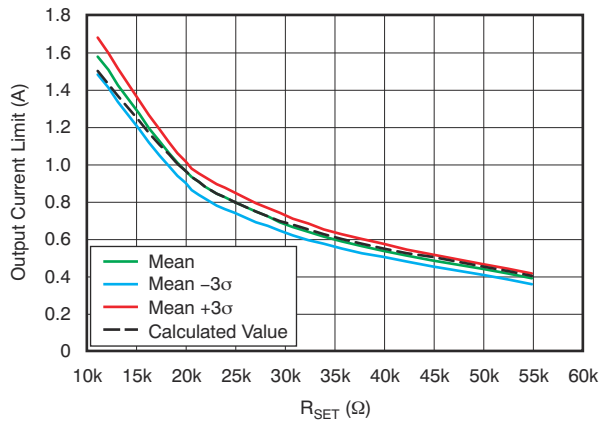

Figure 6-30. Current Limit Percent Error vs  $R_{SET}$

### 6.6 Typical Characteristics (continued)

at  $T_{CASE} = 25^{\circ}C$ ,  $V_S = \pm 12V$ ,  $R_{LOAD} = 20k\Omega$  to GND,  $R_{SET} = 7.5k\Omega$ , and  $E/\bar{S}$  pin enabled (unless otherwise noted)



6-31. Output Current Limit vs  $R_{SET}$  (Sourcing Current)

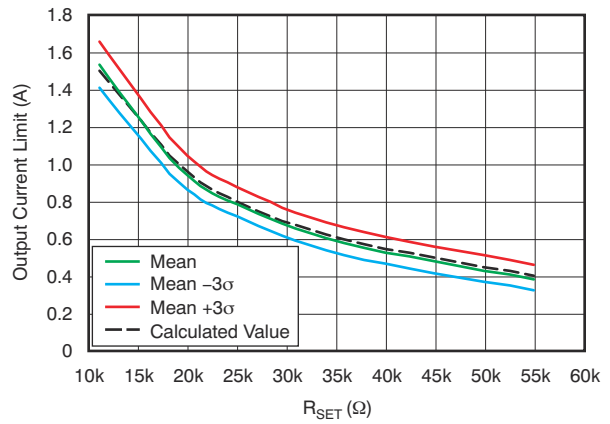

6-32. Output Current Limit vs  $R_{SET}$  (Sinking Current)

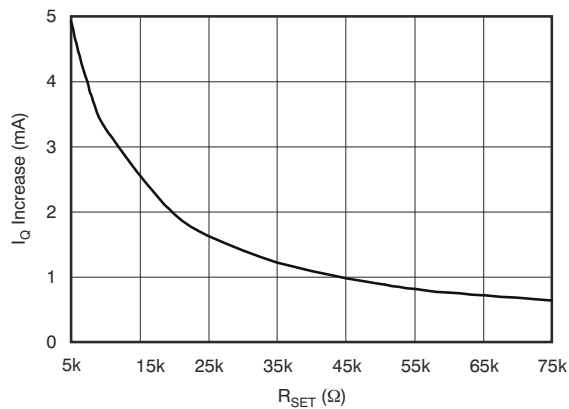

6-33. Quiescent Current Increase vs  $R_{SET}$

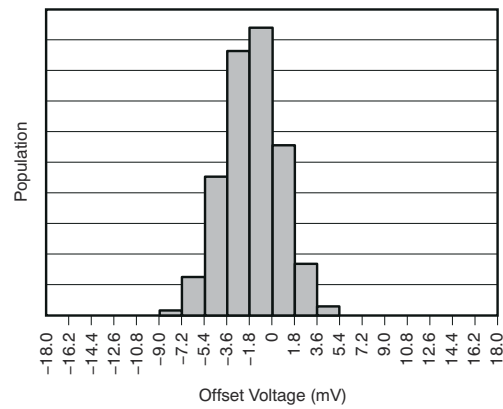

6-34. Offset Voltage Production Distribution

## 7 Detailed Description

### 7.1 Overview

The OPA564-Q1 is a low-cost, high-current op amp that is an excellent choice for driving up to 1.5A into reactive loads. The high slew rate provides 1.3MHz of full-power bandwidth and excellent linearity. These monolithic integrated circuits provide high reliability in demanding powerline communications and motor-control applications.

### 7.2 Functional Block Diagram

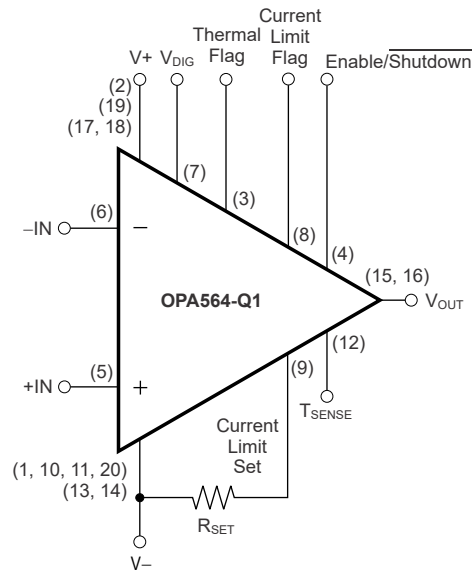

### 7.3 Feature Description

#### 7.3.1 Adjustable Current Limit

The OPA564-Q1 provides overcurrent protection to the load through an accurate, user-adjustable current limit ( $I_{SET}$  pin). The current limit value,  $I_{LIM}$ , can be set from 0.4A to 1.6A by controlling the current through the  $I_{SET}$  pin. Setting the current limit does not require special power resistors. The output current does not flow through the  $I_{SET}$  pin.

A simple resistor to the negative rail is sufficient for a general, coarse limit of the output current. [Figure 6-30](#) exhibits the percent of error in the transfer function between  $I_{SET}$  and  $I_{OUT}$  versus the current limit set resistor,  $R_{SET}$ . The  $\pm 3$  sigma distribution is derived from one lot of material characterized at room temperature. As significant variation can occur from unit to unit and across operating conditions, do not use the adjustable current limit to set an exact output current, but rather, to protect the device. [Figure 6-31](#) and [Figure 6-32](#) show how this error translates to variation in  $I_{OUT}$  versus  $R_{SET}$ . The dotted line represents the ideal output current setting that is determined by the following equation:

$$I_{LIM} \cong 20k \times \left[ \frac{1.2V}{5k\Omega + R_{SET}} \right] \quad (1)$$

The mismatch errors between the current-limit set mirror and the output stage are primarily a result of variations in the approximately 1.2V band-gap reference, an internal 5k $\Omega$  resistor, the mismatch between the current limit and the output stage mirror, and the tolerance and temperature coefficient of the  $R_{SET}$  resistor referenced to the negative rail. Additionally, an increase in junction temperature can induce added mismatch in accuracy between the  $I_{SET}$  and  $I_{OUT}$  mirror. See [Figure 8-7](#) for a method that can be used to dynamically change the current limit setting using a simple, zero-drift current source. This approach simplifies the current-limit equation to the following:

$$I_{LIM} \cong 20k \times I_{SET} \quad (2)$$

The current into the  $I_{SET}$  pin is determined by the NPN current source. Therefore, the errors contributed by the internal 1.2V band-gap reference and the 5k $\Omega$  resistor mismatch are eliminated, thus improving the overall accuracy of the transfer function. In this case, the primary source of error in  $I_{SET}$  is the  $R_{SET}$  resistor tolerance and the beta of the NPN transistor.

The primary intent of the current limit on the OPA564-Q1 is coarse protection of the output stage; therefore, exercise caution when attempting to control the output current by dynamically toggling the current-limit setting. Predictable performance is better achieved by controlling the output voltage through the feedback loop of the OPA564-Q1.

### 7.3.1.1 Setting the Current Limit

Leaving the  $I_{SET}$  pin unconnected damages the device. Connecting  $I_{SET}$  directly to  $V-$  is not recommended because direct connection programs the current limit far beyond the 1.5A capability of the device and causes excess power dissipation. The minimum recommended value for  $R_{SET}$  is 7.5k $\Omega$ , which programs the maximum current limit to approximately 1.9A. The maximum value for  $R_{SET}$  is 55k $\Omega$ , which programs the minimum current limit to approximately 0.4A. The simplest method for adjusting the current limit ( $I_{LIM}$ ) uses a resistor or potentiometer connected between the  $I_{SET}$  pin and  $V-$ , according to 式 1.

If  $I_{LIM}$  has been defined, solve for  $R_{SET}$  by rearranging 式 1 into 式 3:

$$R_{SET} \cong \left[ \frac{24k\Omega}{I_{LIM}} \right] - 5k\Omega \quad (3)$$

$R_{SET}$  in combination with a 5k $\Omega$  internal resistor determines the magnitude of a small current that sets the desired output current limit.

图 7-1 shows a simplified schematic of the OPA564-Q1 current limit architecture.

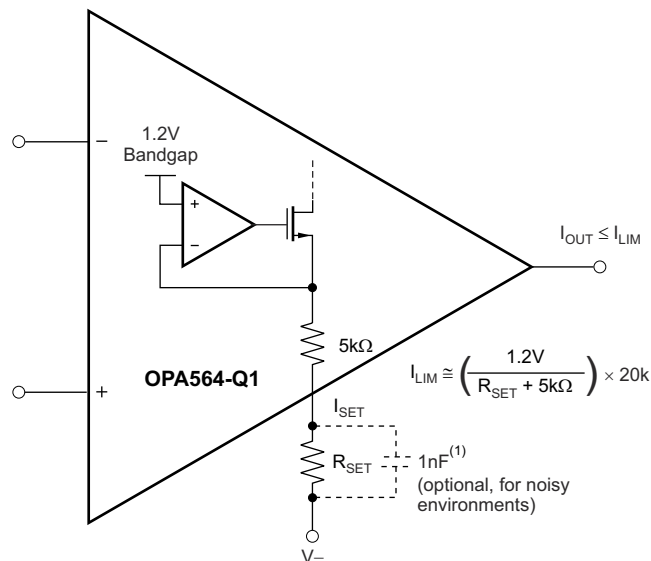

1. At power-on, this capacitor is not charged. Therefore, the OPA564-Q1 is programmed for maximum output current. Capacitor values > 1nF are not recommended.

图 7-1. Adjustable Current Limit

### 7.3.2 Enable and Shutdown (E/S) Pin

The output of the OPA564-Q1 shuts down when the E/S pin is forced low. For normal operation (output enabled), pull the E/S pin high (at least 2V greater than V<sub>-</sub>). To enable the OPA564-Q1 permanently, leave the the E/S pin unconnected. The E/S pin has an internal 100kΩ pullup resistor. When the output is shut down, the output impedance of the OPA564-Q1 is typically 6GΩ || 120pF. [Figure 7-6](#) shows the output shutdown output voltage versus output current. Although the output is high-impedance when shut down, there is still a path through the feedback network into the input stage to ground; see [Figure 7-7](#). To prevent damage to the OPA564-Q1, ensure that the voltage across input pins +IN and -IN does not exceed ±0.5V, and that the current flowing through the input pins does not exceed 10mA when operated beyond the supply rails, V<sub>-</sub> and V<sub>+</sub>; see also [Input Protection](#).

### 7.3.3 Input Protection

Electrostatic discharge (ESD) protection followed by back-to-back diodes and input resistors (see [Figure 7-7](#)) are used for input protection on the OPA564-Q1. Exceeding the turn-on threshold of these diodes, as in a pulse condition, can cause current to flow through the input protection diodes because of the finite slew rate of the amplifier. If the input current is not limited, the back-to-back diodes and the input devices can be destroyed. Sources of high input current can also cause subtle damage to the amplifier. Although the unit can still function, important parameters such as input offset voltage, drift, and noise can shift.

When using the OPA564-Q1 as a unity-gain buffer (follower), as an inverting amplifier, or in shutdown mode, limit the input voltage between the input terminals (+IN and -IN) so that the voltage does not exceed 0.5V. Maintain this condition across the entire common-mode range from V<sub>-</sub> to V<sub>+</sub>. If the inputs exceed either supply rail, limit the current to 10mA through the ESD protection diodes. During excursions past the rails, limit the voltage across the input terminals. If necessary, add external back-to-back diodes between +IN and -IN to maintain the 0.5V requirement between these connections.

### 7.3.4 Output Shutdown

The shutdown pin (E/S) is referenced to the negative supply (V<sub>-</sub>). Therefore, shutdown operation is slightly different in single-supply and dual-supply applications. In single-supply operation, V<sub>-</sub> typically equals common ground. Therefore, the shutdown logic signal and the OPA564-Q1 shutdown pin are referenced to the same potential. In this configuration, the logic pin and the OPA564-Q1 enable can simply be connected together. Shutdown occurs for voltage levels of less than 0.8V. The OPA564-Q1 is enabled at logic levels greater than 2V. In dual-supply operation, the logic pin remains referenced to a logic ground. However, the shutdown pin of the OPA564-Q1 continues to be referenced to V<sub>-</sub>.

Thus, in a dual-supply system, to shut down the OPA564-Q1 the voltage level of the logic signal must be level-shifted by some means. One way to shift the logic signal voltage level is by using an optocoupler, as [Figure 7-2](#) shows.

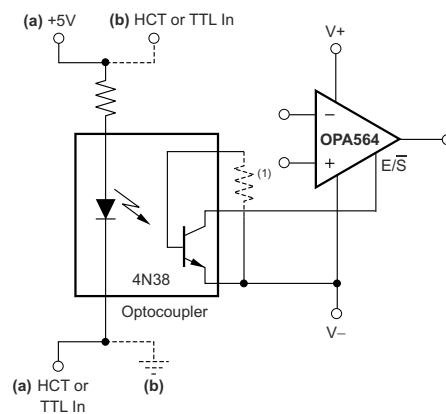

Copyright © 2017, Texas Instruments Incorporated

1. Optional; can be required to limit leakage current of optocoupler at high temperatures.

**Figure 7-2. Shutdown Configuration for Dual Supplies (Using Optocoupler)**

To shut down the output, the  $E/\overline{S}$  pin is pulled low, no greater than 0.8V greater than  $V^-$ . This function can be used to conserve power during idle periods. To return the output to an enabled state, pull the  $E/\overline{S}$  pin to at least 2.0V greater than  $V^-$ . [Figure 6-27](#) shows the typical enable and shutdown response times. Be aware that the  $E/\overline{S}$  pin does not affect the internal thermal shutdown.

When the OPA564-Q1 is used in applications where the device shuts down, take special care with respect to input protection. Consider the following two examples.

[Figure 7-3](#) shows the amplifier in a follower configuration. The load is connected midway between the supplies,  $V^+$  and  $V^-$ .

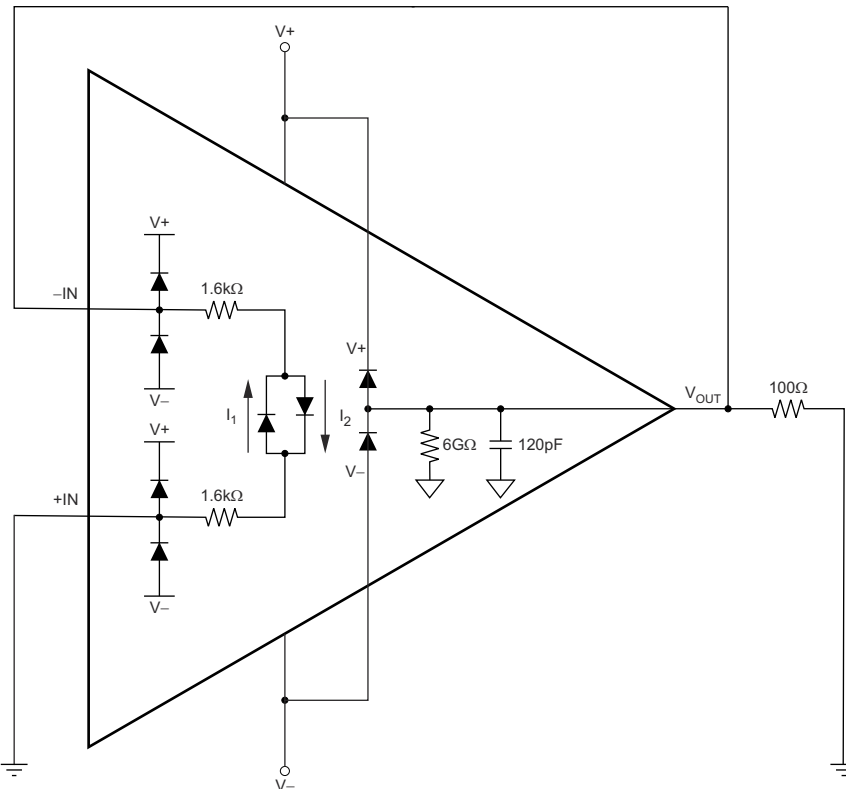

Copyright © 2017, Texas Instruments Incorporated

### **Figure 7-3. Shutdown Equivalent Circuit With Load Connected Midway Between Supplies**

When the device shuts down in this situation, the load pulls  $V_{OUT}$  to ground. Little or no current then flows through the input of the OPA564-Q1.

Now consider [Figure 7-4](#). Here, the load is connected to  $V^-$ . When the device shuts down, current flows from the positive input  $+IN$  through the first 1.6kΩ resistor through an input protection diode, then through the second 1.6kΩ resistor, and finally through the 100Ω resistor to  $V^-$ .

#### **注意**

This configuration damages the device.



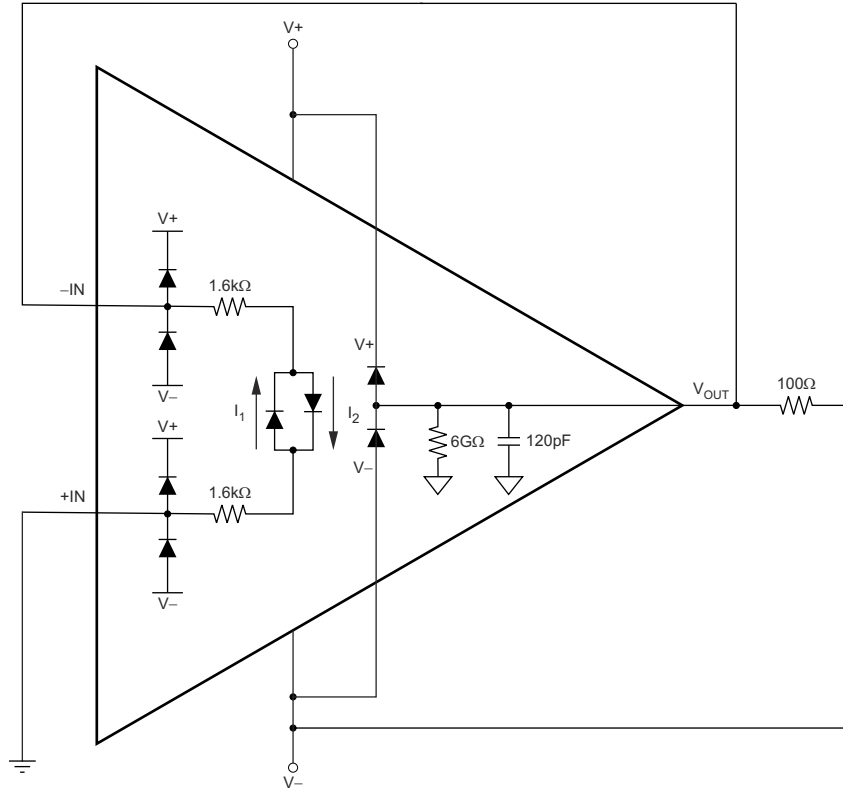

Copyright © 2017, Texas Instruments Incorporated

**☒ 7-4. Shutdown Equivalent Circuit With Load Connected to V-:  
 Voltage Across Inputs During Disable Exceeds Input Requirements**

This current flow produces a voltage across the inputs that is much greater than 0.5V, which damages the OPA564-Q1. A similar problem occurs if the load is connected to the positive supply.

The solution is to place external protection diodes across the OPA564-Q1 input.  7-5 illustrates this configuration.

注

This configuration protects the input during shutdown.

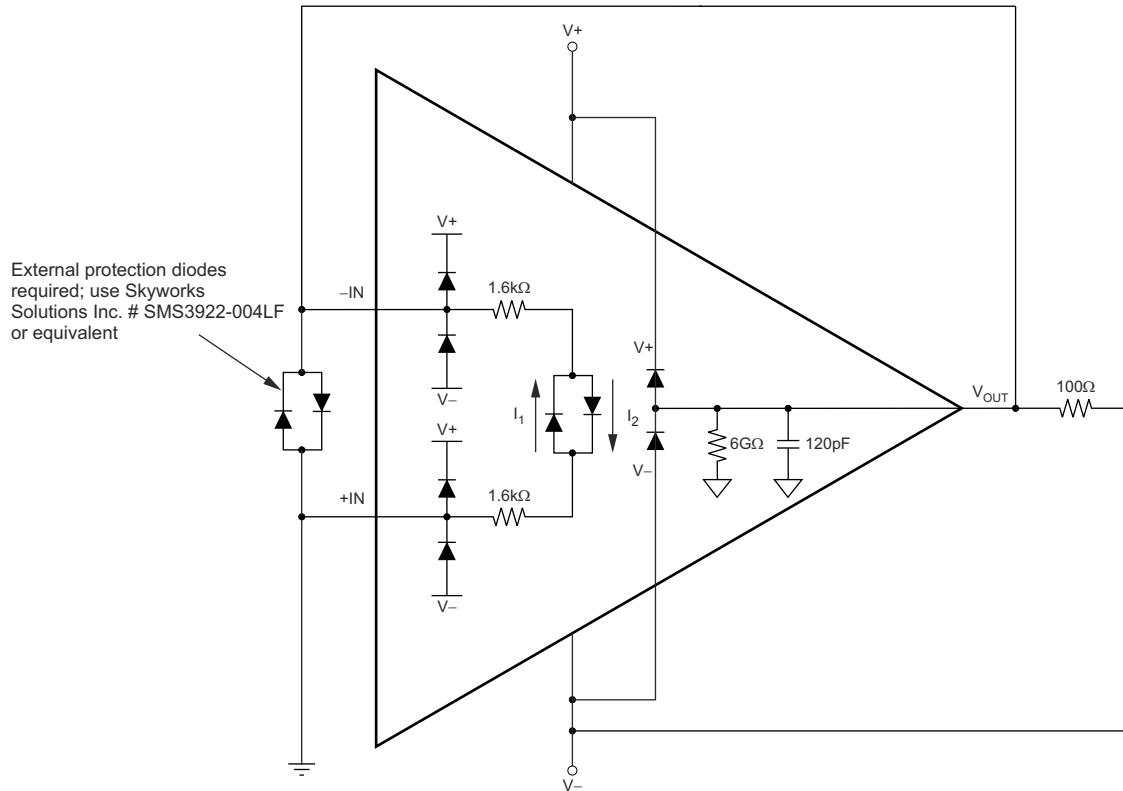

Copyright © 2017, Texas Instruments Incorporated

 7-5. Shutdown Equivalent Circuit With Load Connected to V-: Protected Input Configuration

### 7.3.5 Microcontroller Compatibility

Not all microcontrollers output the same logic state after power-up or reset. 8051-type microcontrollers, for example, output logic high levels while other models power up with logic low levels after reset. In the configuration of [Figure 7-2 \(a\)](#), the shutdown signal is applied on the cathode side of the photodiode within the optocoupler. A high logic level causes the OPA564-Q1 to be enabled, and a low logic level shuts the OPA564-Q1 down. In the configuration of [Figure 7-2 \(b\)](#), with the logic signal applied on the anode side, a high level causes the OPA564-Q1 to shut down, and a low level enables the op amp.

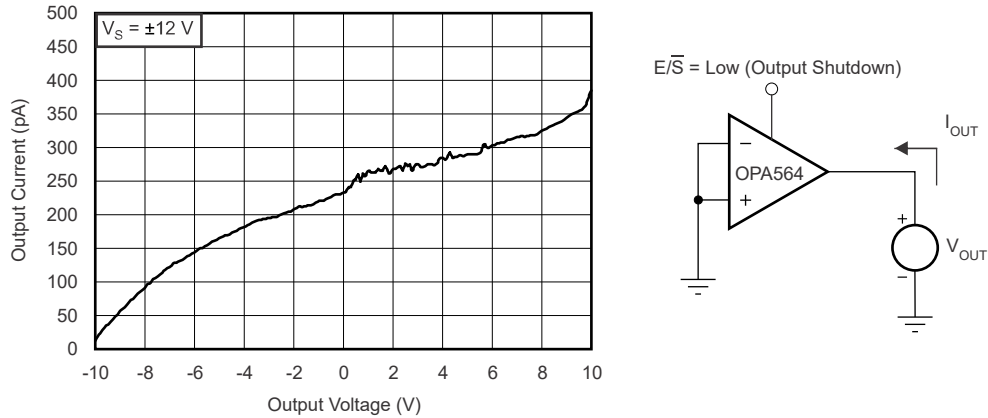
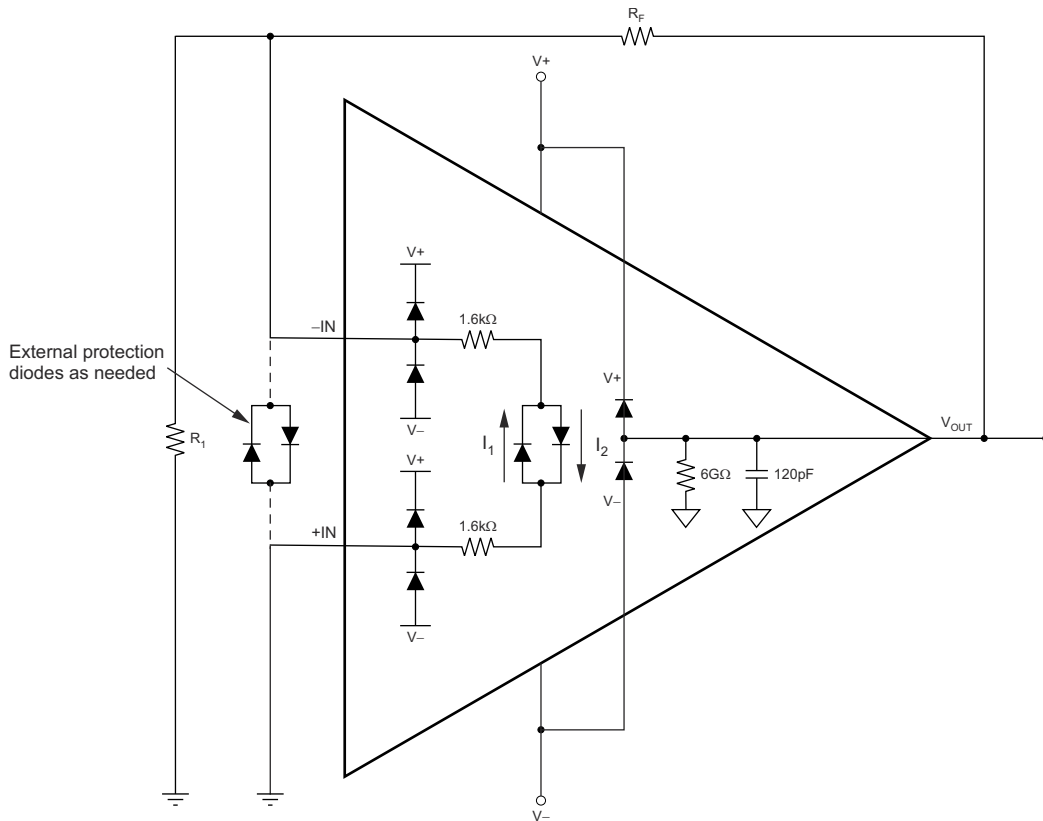

Figure 7-6. Output Shutdown Output Impedance



Copyright © 2017, Texas Instruments Incorporated

Figure 7-7. OPA564-Q1: Output Shutdown Equivalent Circuit (With External Feedback)

### 7.3.6 Current Limit Flag

The OPA564-Q1 features a current limit flag ( $I_{FLAG}$ ) that can be monitored to determine if the load current is operating within or exceeding the current limit set by the user. The output signal of  $I_{FLAG}$  is compatible with standard CMOS logic and is referenced to the negative supply pin ( $V-$ ). A voltage level of 0.8V or less with respect to  $V-$  indicates that the amplifier is operating within the limits set by the user. A voltage level of 2.0V or greater with respect to  $V-$  indicates that the OPA564-Q1 operation exceeds the current limit set by the user. See also [セクション 7.3.1.1](#). Either read the  $I_{FLAG}$  pin with a high-impedance digital I/O pin, or buffer the  $I_{FLAG}$  pin.

### 7.3.7 Thermal Protection

The OPA564-Q1 has thermal sensing circuitry that helps protect the amplifier from exceeding temperature limits. Power dissipated in the OPA564-Q1 causes the junction temperature to rise. Internal thermal shutdown circuitry disables the output when the die temperature reaches the thermal shutdown temperature limit. The OPA564-Q1 output remains shut down until the die has cooled sufficiently; see the *Electrical Characteristics, Thermal Shutdown* section. When the OPA564-Q1 is in thermal shutdown, the device asserts the  $T_{FLAG}$  pin high. The  $T_{FLAG}$  pin returns low when the device returns to normal operation. Read the  $T_{FLAG}$  pin with a high-impedance digital I/O pin, or buffer the  $T_{FLAG}$  pin.

Depending on load and signal conditions, the thermal protection circuit can cycle on and off. This cycling limits the amplifier dissipation, but can have undesirable effects on the load. Any tendency to activate the thermal protection circuit indicates excessive power dissipation or an inadequate heat sink. For reliable, long-term, continuous operation, with  $I_{OUT}$  at the maximum output of 1.5A, limit the junction temperature to 85°C maximum. [図 7-8](#) shows the maximum output current versus junction temperature for dc and RMS signal outputs. To estimate the margin of safety in a complete design (including heat sink), increase the ambient temperature until the thermal protection triggers. Use worst-case loading and signal conditions. For good, long-term reliability, thermal protection triggers when the maximum expected ambient condition of the application is exceeded by 35°C.

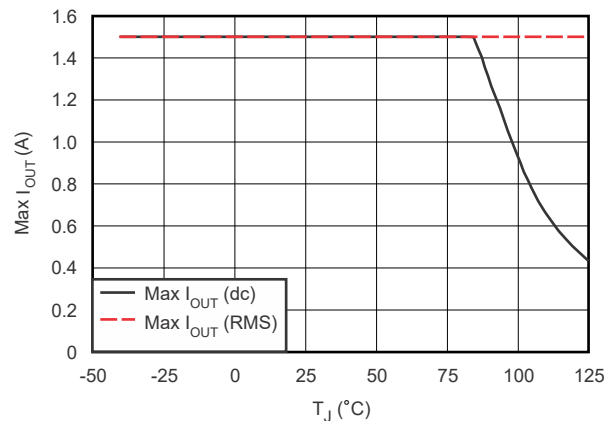

**図 7-8. Maximum Output Current vs Junction Temperature**

The internal protection circuitry of the OPA564-Q1 is designed to protect against overload conditions; this circuitry was not intended to replace a proper heat sink. Continuously running the OPA564-Q1 into thermal shutdown degrades reliability.

### 7.3.8 Junction Temperature Measurement Using $T_{SENSE}$

The OPA564-Q1 includes an internal diode for junction temperature monitoring. The  $\eta$ -factor of this diode is typically 1.033. To measure the OPA564-Q1 junction temperature, connect the  $T_{SENSE}$  pin to a remote-junction temperature sensor, such as the [TMP411](#) (see [図 8-13](#)).

## 7.4 Device Functional Modes

The device has two modes of operation: normal and low-power shutdown.

## 8 Application and Implementation

### 注

以下のアプリケーション情報は、TI の製品仕様に含まれるものではなく、TI ではその正確性または完全性を保証いたしません。個々の目的に対する製品の適合性については、お客様の責任で判断していただくこととなります。お客様は自身の設計実装を検証しテストすることで、システムの機能を確認する必要があります。

### 8.1 Application Information

#### 8.1.1 Basic Configuration

図 8-1 shows the OPA564-Q1 connected as a basic noninverting amplifier. However, the OPA564-Q1 can be used in virtually any op-amp configuration.

Bypass power-supply pins with low series impedance capacitors. The technique of using ceramic and tantalum capacitors in parallel is recommended. Use power-supply wiring with a low series impedance.

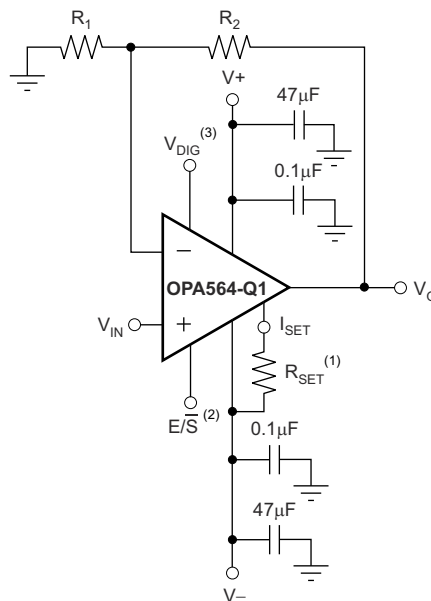

1.  $R_{SET}$  sets the current limit value from 0.4A to 1.5A.
2.  $E/\overline{S}$  pin forced low shuts down the output.
3.  $V_{DIG}$  must not exceed  $(V-) + 5.5V$ ; see 図 8-12 for examples of generating a signal for  $V_{DIG}$ .

図 8-1. Basic Noninverting Amplifier

### 8.1.2 Output-Stage Compensation

The complex load impedances common in power op-amp applications can cause output-stage instability. For normal operation, output compensation circuitry is typically not required. However, if the OPA564-Q1 is intended to be driven into current limit, an R/C network (snubber) can be required. A snubber circuit, such as the one shown in [Figure 8-10](#) can also enhance stability when driving large capacitive loads (greater than 1000pF) or inductive loads (for example, motors or loads separated from the amplifier by long cables). Typically, 3Ω to 10Ω in series with 0.01μF to 0.1μF is adequate. Some variations in circuit value can be required with certain loads.

### 8.1.3 Output Protection

The output structure of the OPA564-Q1 includes ESD diodes (see [Figure 7-7](#)). Do not allow the voltage at the OPA564-Q1 output to exceed 0.4V beyond either supply rail to avoid damage to the device. Reactive and electromagnetic field (EMF) generation loads can return load current to the amplifier, causing the output voltage to exceed the power-supply voltage. [Figure 8-10](#) and [Figure 8-11](#) illustrate how to avoid this damaging condition with clamping diodes from the output pin to the power supplies. Schottky rectifier diodes with a 3A or greater continuous rating are recommended.

### 8.1.4 Power Dissipation and Safe Operating Area

Power dissipation depends on power supply, signal, and load conditions. For dc signals, power dissipation is equal to the product of output current ( $I_{OUT}$ ) and the voltage across the conducting output transistor [ $(V+) - V_{OUT}$  when sourcing;  $V_{OUT} - (V-)$  when sinking]. Dissipation with ac signals is lower. See the [Power Amplifier Stress and Power Handling Limitations application bulletin](#), available for download from [www.ti.com](http://www.ti.com), for an explanation on how to calculate or measure power dissipation with unusual signals and loads.

[Figure 8-2](#) shows the safe operating area at room temperature with various heat-sinking efforts. Note that the safe output current decreases as  $(V+) - V_{OUT}$  or  $V_{OUT} - (V-)$  increases. [Figure 8-3](#) shows the safe operating area at various temperatures with the thermal pad being soldered to a 2oz copper pad.

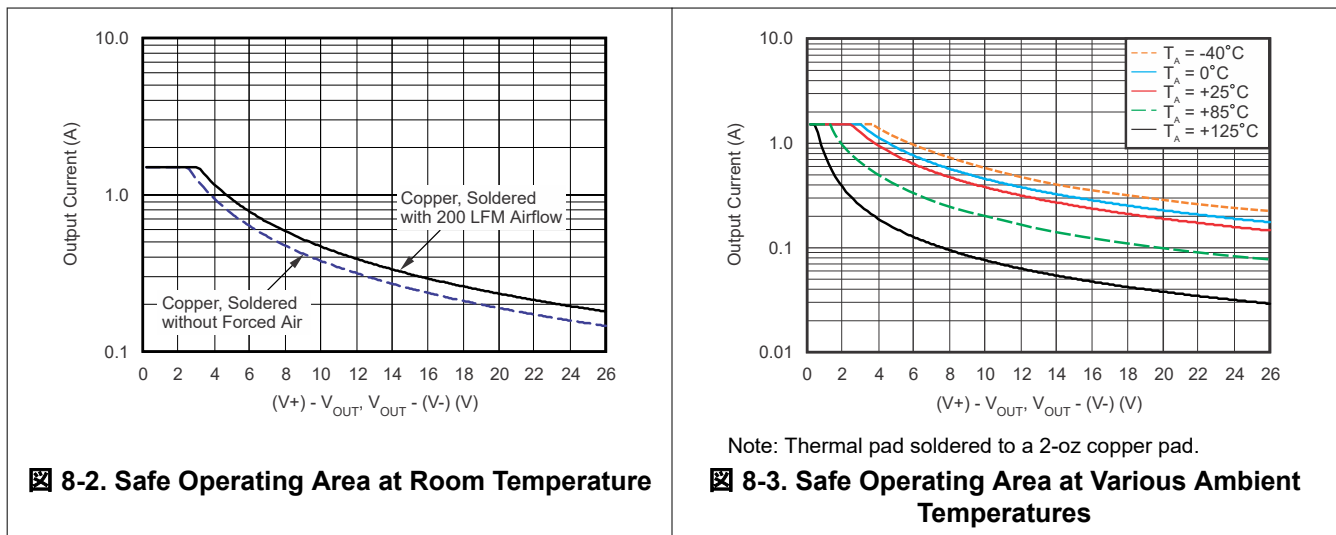

The power that can be safely dissipated in the package is related to the ambient temperature and the heat-sink design. The PowerPAD integrated circuit package was specifically designed to provide excellent power dissipation, but board layout greatly influences the heat dissipation of the package. See [セクション 8.4.1.1](#) section for further details.

The relationship between thermal resistance and power dissipation can be expressed as:

$$T_J = T_A + T_{JA} \quad (4)$$

$$T_{JA} = P_D \times \theta_{JA} \quad (5)$$

Combining these equations produces:

$$T_J = T_A + P_D \times \theta_{JA} \quad (6)$$

where:

- $T_J$  = Junction temperature (°C)
- $T_A$  = Ambient temperature (°C)
- $\theta_{JA}$  = Junction-to-ambient thermal resistance (°C/W)
- $P_D$  = Power dissipation (W)

To determine the required heat-sink area, calculate the required power dissipation and consider the relationship between power dissipation and thermal resistance to minimize shutdown conditions and allow for proper long-term operation (junction temperature of 85°C or less).

After the heat-sink area has been selected, test for worst-case load conditions to maintain proper thermal protection.

For applications with limited board size, see [図 8-4](#) for the approximate thermal resistance relative to heat-sink area. Increasing heat-sink area beyond 2in<sup>2</sup> provides little improvement in thermal resistance. To achieve the 28.7°C/W shown in *Thermal Information*, a 2oz copper plane size of 3in<sup>2</sup> is used. The PowerPAD integrated circuit package is designed for continuous power levels from 2W to 4W, depending on ambient temperature and heat-sink area. The addition of airflow also influences maximum power dissipation, as [図 8-5](#) illustrates. Higher power levels can be achieved in applications with a low on and off duty cycle, such as remote meter reading.

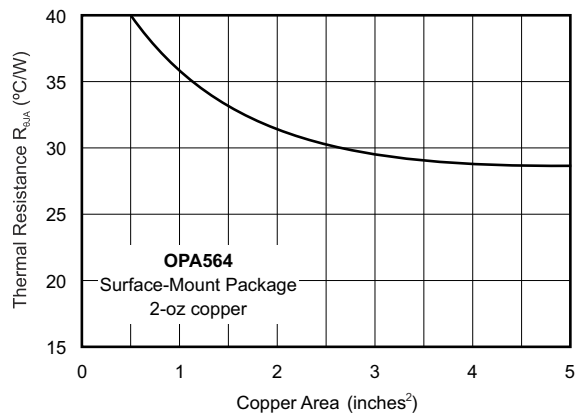

**図 8-4. Thermal Resistance vs Circuit Board Copper Area**

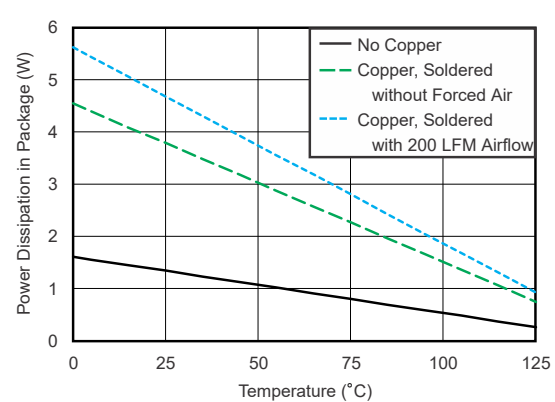

**図 8-5. Maximum Power Dissipation vs Temperature**



## 8.2 Typical Applications

### 8.2.1 Improved Howland Current Pump

The high output current and low supply of the OPA564-Q1 make this device a good candidate for driving laser diodes and thermoelectric coolers. [Figure 8-6](#) shows an improved Howland current pump circuit.

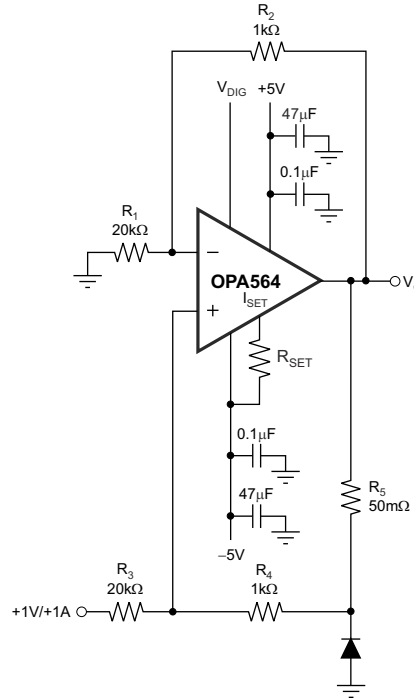

**Figure 8-6. Improved Howland Current Pump**

### 8.2.2 Programmable Power Supply

[Figure 8-7](#) shows how the OPA333 is used to control  $I_{SET}$  to adjust the current limit of the OPA564-Q1. Ensure that the ground used as the reference for  $V_{SET}$  and  $R_{SET}$  is approximately equal to  $V_-$ .

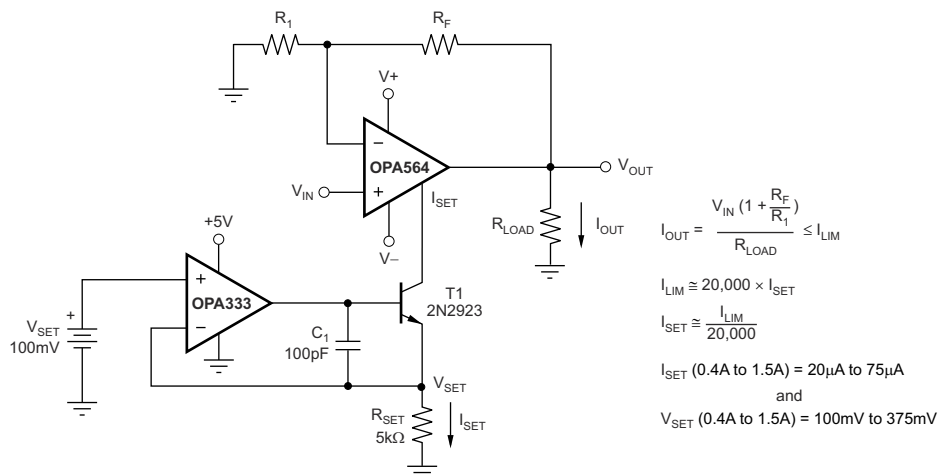

Copyright © 2017, Texas Instruments Incorporated

**Figure 8-7. Programmable Current Limit Option**

### 8.2.3 Powerline Communication

Powerline-communication (PLC) applications require some form of signal transmission over an existing ac power line. A common technique used to couple these modulated signals to the line is through a signal transformer. A power amplifier is often needed to provide adequate levels of current and voltage to drive the varying loads that exist on modern powerlines. [Figure 8-8](#) shows one such application. The OPA564-Q1 is used to drive signals used in frequency modulation schemes such as frequency-shift keying (FSK) or orthogonal frequency-division multiplexing (OFDM) to transmit digital information over the powerline. The power output capabilities of the OPA564-Q1 are needed to drive the current requirements of the transformer that is shown in the figure, coupled to the ac power line via a coupling capacitor. Circuit protection is often required to prevent excessive line voltages or current surges from damaging the active circuitry in the power amplifier and application circuitry.

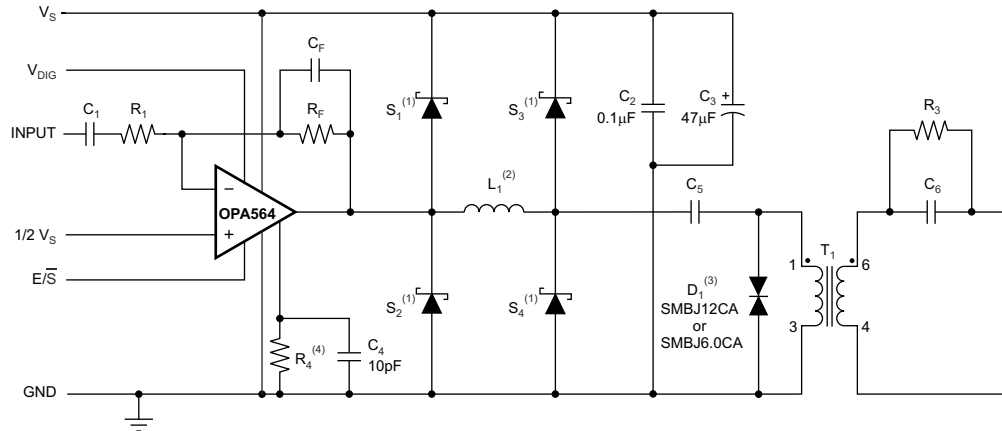

Copyright © 2017, Texas Instruments Incorporated

1.  $S_1$ ,  $S_2$ ,  $S_3$ , and  $S_4$  are Schottky diodes.  $S_1$  and  $S_2$  are B350 or equivalent.  $S_3$  and  $S_4$  are BAV99T or equivalent.
2. Ensure that  $L_1$  is small enough so that  $L_1$  does not interfere with the bandwidth of interest, but large enough to suppress transients that can damage the OPA564-Q1.
3.  $D_1$  is a transient suppression diode. For 24V supplies, use SMBJ12CA. For 12V supplies, use SMBJ6.0CA. Ensure that the voltage rating of the transient voltage suppressor is half the supply rating or less.
4. The minimum recommended value for  $R_4$  is 7.5k $\Omega$ .

### **Figure 8-8. Powerline Communication Line Coupling**

[Figure 8-9](#) illustrates a detailed powerline communication circuit.

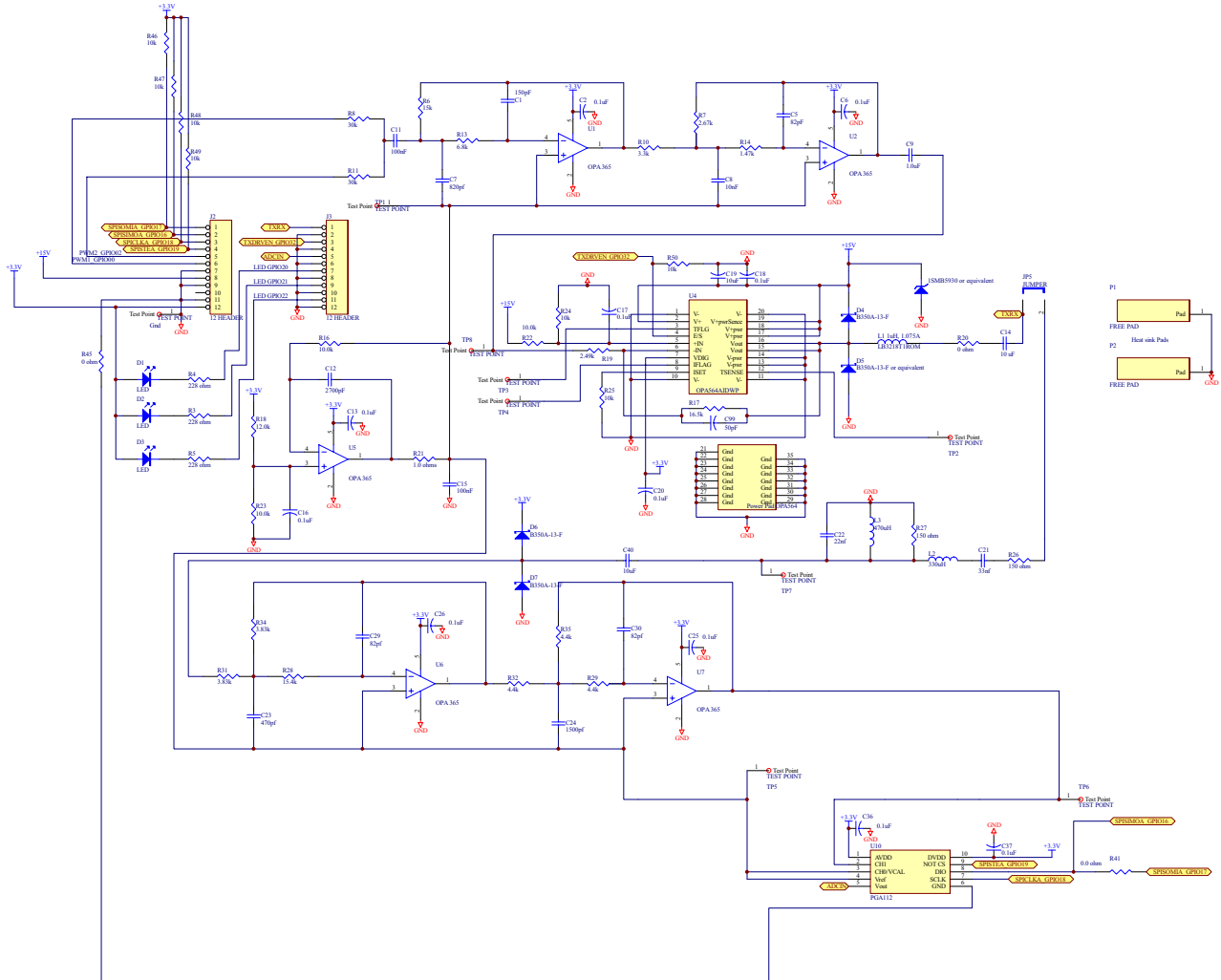

Copyright © 2017, Texas Instruments Incorporated

**8-9. Detailed Powerline Communication Circuit**

## 8.2.4 Motor-Drive Circuit

Figure 8-10 shows a basic motor-speed driver, but does not include any control over the motor speed.

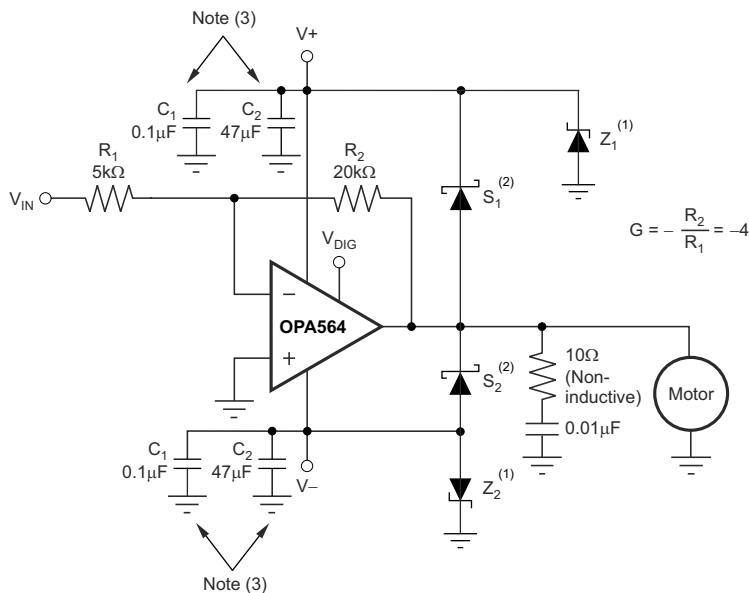

1.  $Z_1, Z_2$  = zener diodes (IN5246 or equivalent). Select  $Z_1$  and  $Z_2$  diodes that are capable of the maximum anticipated surge current.
2.  $S_1, S_2$  = Schottky diodes (STPS1L40 or equivalent).
3.  $C_1$  = high-frequency bypass capacitors;  $C_2$  = low-frequency bypass capacitors (minimum of 10μF for every 1A peak current)

Figure 8-10. Motor-Drive Circuit

### 8.2.5 DC Motor-Speed Controller (Without Tachometer)

For applications where good control of the speed of the motor is desired, but the precision of a tachometer control is not required, the circuit in [Figure 8-11](#) provides control by using feedback of the current consumption to adjust the motor drive.

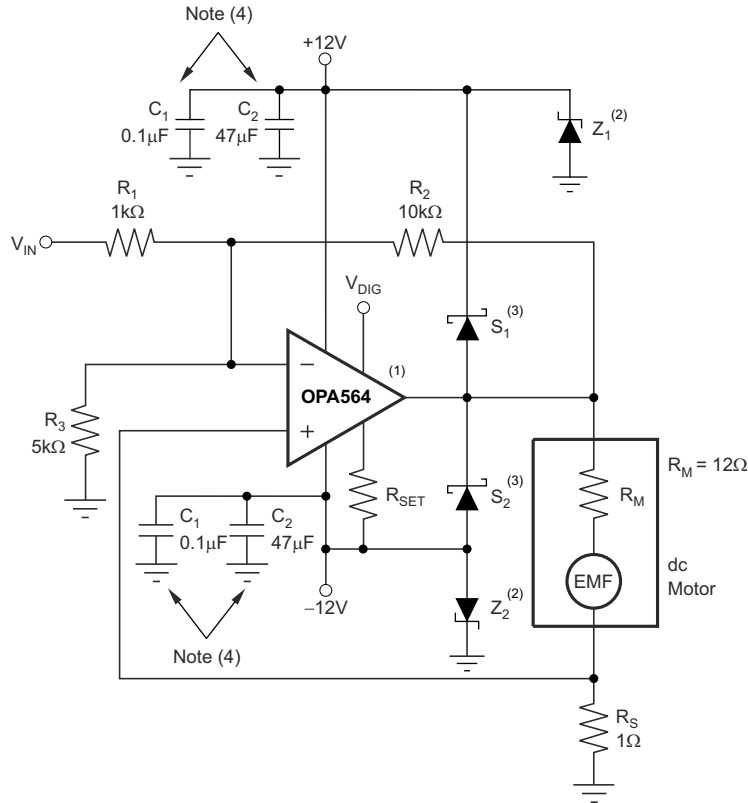

Copyright © 2017, Texas Instruments Incorporated

1. I<sub>FLAG</sub> and T<sub>FLAG</sub> connections are not shown.
2. Z<sub>1</sub>, Z<sub>2</sub> = zener diodes (IN5246 or equivalent). Select Z<sub>1</sub> and Z<sub>2</sub> diodes that are capable of the maximum anticipated surge current.
3. S<sub>1</sub>, S<sub>2</sub> = Schottky diodes (STPS1L40 or equivalent).
4. C<sub>1</sub> = high-frequency bypass capacitors; C<sub>2</sub> = low-frequency bypass capacitors (minimum of 10μF for every 1A peak current).

**Figure 8-11. DC Motor-Speed Controller (Without Tachometer)**

For more information on this circuit, see the [DC Motor Speed Controller: Control a DC Motor without Tachometer Feedback](#) application bulletin, available for download at [www.ti.com](http://www.ti.com).

### 8.2.6 Generating $V_{DIG}$

Figure 8-12 shows two examples of generating the signal for  $V_{DIG}$ . Figure 8-12(a) uses an 1N4732A zener to bias the  $V_{DIG}$  to precisely 4.7V greater than  $V_-$ . Figure 8-12(b) uses a high-voltage subregulator to derive the  $V_{DIG}$  voltage. Ensure that any decoupling capacitance present on the  $V_{DIG}$  pin does not cause a timing condition that violates the power-supply sequencing outlined in Section 8.3.

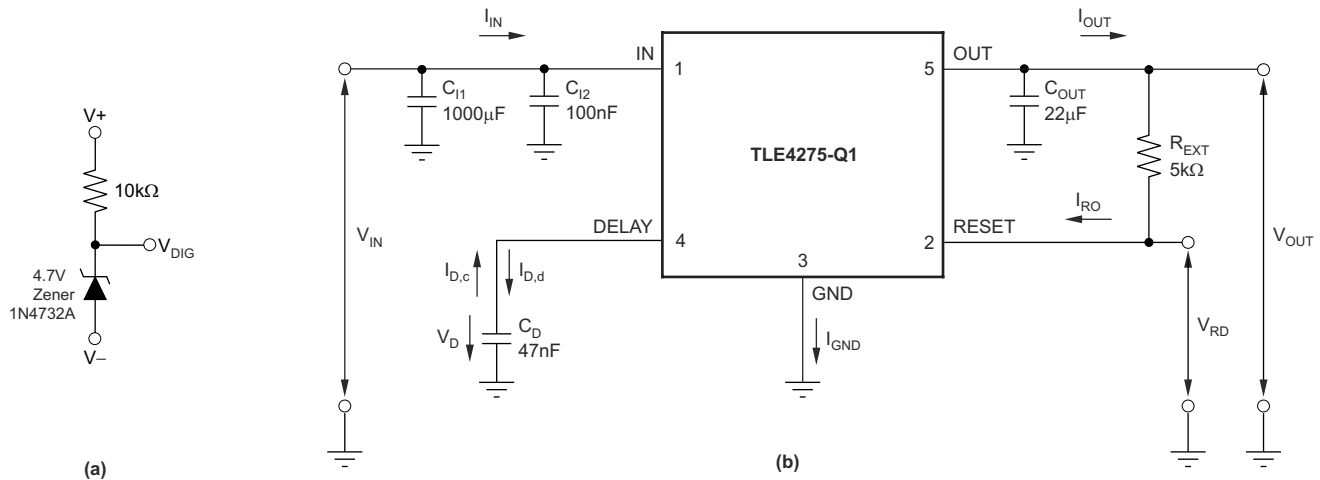

Copyright © 2017, Texas Instruments Incorporated

Figure 8-12. Circuits to Generate  $V_{DIG}$

### 8.2.7 Temperature Measurement

The OPA564-Q1 includes an internal diode for junction temperature monitoring. The  $\eta$ -factor of this diode is typically 1.033. Figure 8-13 shows that to measure the OPA564-Q1 junction temperature, connect the  $T_{SENSE}$  pin to a remote-junction temperature sensor, such as the TMP411.

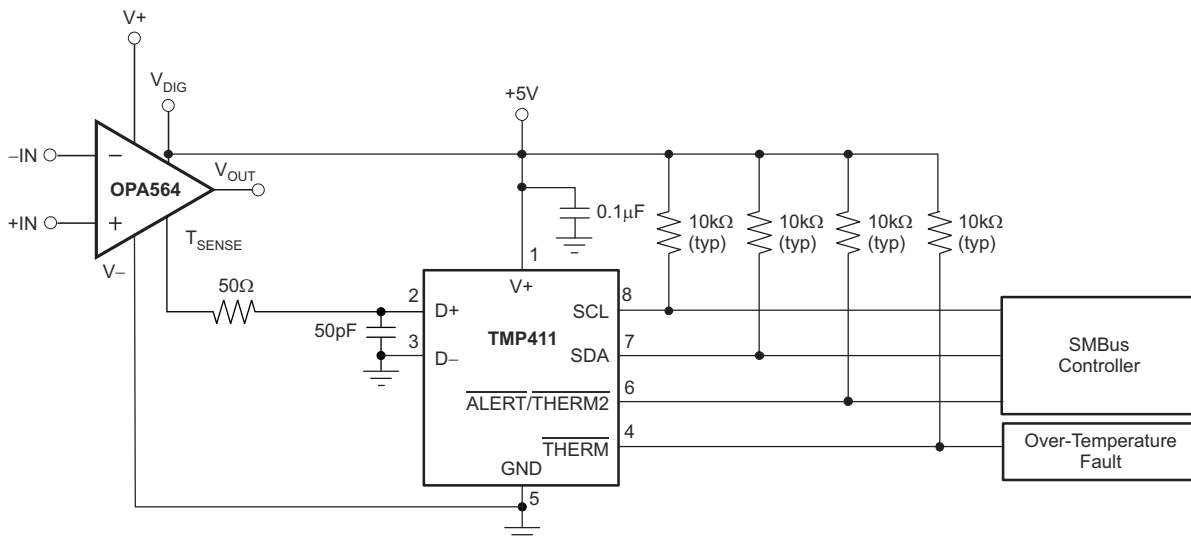

Copyright © 2017, Texas Instruments Incorporated

Figure 8-13. Temperature Measurement Using  $T_{SENSE}$  and the TMP411

### 8.3 Power Supply Recommendations

The OPA564-Q1 operates with excellent performance from single (7V to 24V) or dual ( $\pm 3.5\text{V}$  to  $\pm 12\text{V}$ ) analog supplies and a digital supply of 3.3V to 5.5V (referenced to the V– pin). The analog power-supply voltages do not need to be symmetrical, as long as the total voltage remains less than 24V. For example, the positive supply can be set to 14V with the negative supply at  $-10\text{V}$ . Most behaviors remain constant across the operating voltage range. [セクション 6.6](#) shows the parameters that vary significantly with operating voltage.

To prevent damage to the OPA564-Q1, ensure that the digital supply voltage ( $V_{\text{DIG}}$ ) is applied before the supply voltage when sequencing power supplies. [図 8-14](#) shows acceptable versus unacceptable power-supply sequencing.

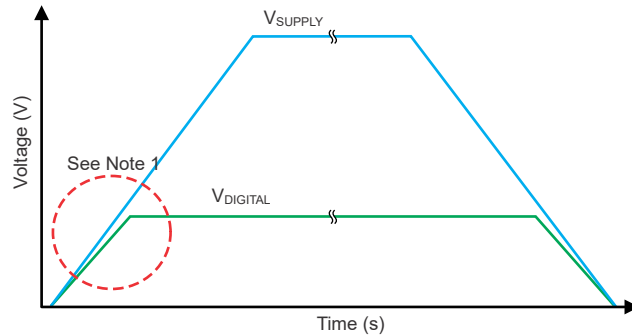

(A) Sequence not allowed<sup>(1)</sup>

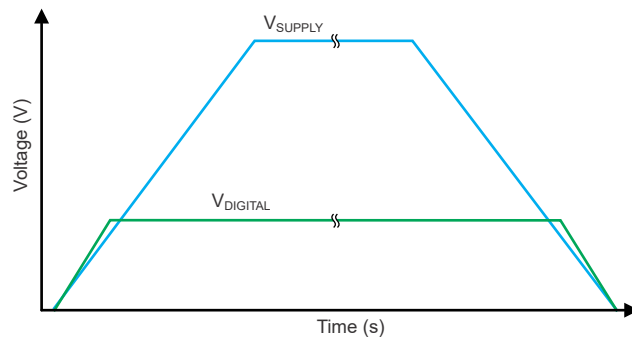

(B) Sequence allowed

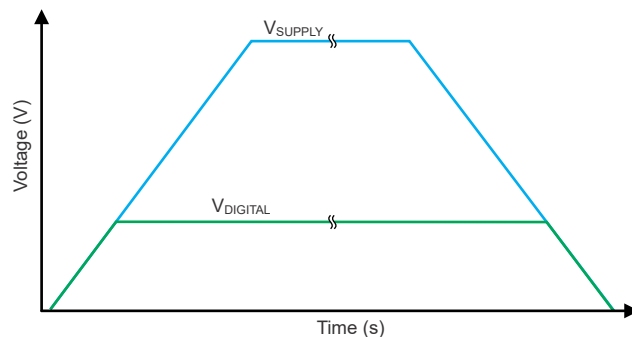

(C) Sequence allowed

(1) The power-supply sequence illustrated in (A) is not allowed because this power-supply sequence damages the device.

#### **図 8-14. Power-Supply Sequencing**

## 8.4 Layout

### 8.4.1 Layout Guidelines

#### 8.4.1.1 Thermally Enhanced PowerPAD™ Integrated Circuit Package

The OPA564-Q1 uses the HSOIC-20 PowerPAD integrated circuit package (DWP), a thermally-enhanced, standard size integrated-circuit (IC) package. This package enhances power dissipation capability significantly. This package is easily mounted using standard printed circuit board (PCB) assembly techniques, and can be removed and replaced using standard repair procedures.

Figure 8-15 shows how DWP package is designed so that the leadframe die pad (or thermal pad) is exposed on the bottom of the IC. The thermal pad provides an extremely low thermal resistance ( $\theta_{JC}$ ) path between the die and the exterior of the package.

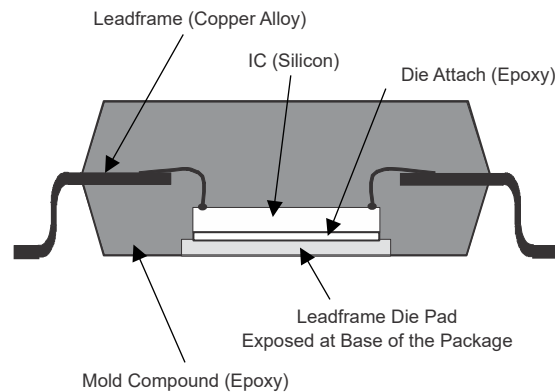



Figure 8-15. Cross-Section Views

The PowerPAD integrated circuit package with exposed pad down are designed to be soldered directly to the PCB, using the PCB as a heat sink. Texas Instruments does not recommend the use of the PowerPAD integrated circuit package without soldering the package to the PCB because of the risk of lower thermal performance and mechanical integrity. In addition, through the use of thermal vias, the bottom-side thermal pad can be directly connected to a power plane or special heat-sink structure designed into the PCB. Ensure that the thermal pad is at the same voltage potential as  $V_{-}$ . Always solder the bottom-side thermal pad to the PCB, even with applications that have low power dissipation. The solder provides the necessary thermal and mechanical connection between the leadframe die and the PCB.



#### 8.4.1.1.1 Bottom-Side Thermal Pad Assembly Process

1. The thermal pad must be connected to the most negative supply of the device,  $V_{-}$ .
2. Prepare the PCB with a top-side etch pattern, as shown in the attached thermal land pattern mechanical drawing. Use etch for the leads as well as etch for the thermal land.
3. Place the recommended number of holes (or thermal vias) in the area of the thermal pad, as seen in the attached thermal land pattern mechanical drawing. These holes are 13 mils (0.013in, or 330.2 $\mu$ m) in diameter. Keep the holes small so that solder wicking through the holes is not a problem during reflow.
4. For optimized performance, place a small number of the holes under the package and outside the thermal pad area. These holes provide an additional heat path between the copper land and ground plane and are 25 mils (0.025in, or 635 $\mu$ m) in diameter. These holes can be larger because these holes are not in the area to be soldered; therefore, wicking is not a problem. This configuration is illustrated in the attached thermal land pattern mechanical drawing.
5. Connect all holes, including those within the thermal pad area and outside the pad area, to the internal plane that is at the same voltage potential as  $V_{-}$ .
6. When connecting these holes to the internal plane, do not use the typical web or spoke via connection methodology (as  8-16 shows). Web connections have a high thermal resistance connection that is useful for slowing heat transfer during soldering operations. This configuration makes the soldering of vias that have plane connections easier. However, in this application, low thermal resistance is desired for the most efficient heat transfer. Therefore, connect the holes under the PowerPAD integrated circuit package to the internal plane with a complete connection around the entire circumference of the plated through-hole.
7. Leave the terminals of the package and the thermal pad area exposed through the top-side solder mask. Leave the 13-mil holes exposed through the thermal pad area. Cover the larger 25-mil holes outside the thermal pad area with solder mask.
8. Apply solder paste to the exposed thermal pad area and all of the package terminals.
9. With these preparatory steps completed, the PowerPAD integrated circuit package is simply placed in position and run through the solder-reflow operation as with any standard surface-mount component. This processing results in a device that is properly installed.

For detailed information on the PowerPAD integrated circuit package, including thermal modeling considerations and repair procedures, see the [PowerPAD Thermally Enhanced Package technical brief](#), available at [www.ti.com](http://www.ti.com).

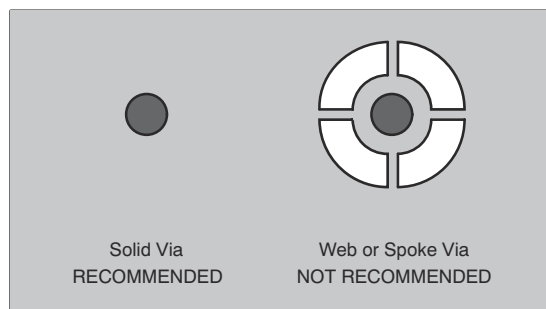

 **8-16. Via Connection Methods**

## 9 Device and Documentation Support

TI offers an extensive line of development tools. Tools and software to evaluate the performance of the device, generate code, and develop solutions are listed below.

### 9.1 ドキュメントの更新通知を受け取る方法

ドキュメントの更新についての通知を受け取るには、[www.tij.co.jp](http://www.tij.co.jp) のデバイス製品フォルダを開いてください。[通知] をクリックして登録すると、変更されたすべての製品情報に関するダイジェストを毎週受け取ることができます。変更の詳細については、改訂されたドキュメントに含まれている改訂履歴をご覧ください。

### 9.2 サポート・リソース

テキサス・インスツルメンツ E2E™ サポート・フォーラムは、エンジニアが検証済みの回答と設計に関するヒントをエキスパートから迅速かつ直接得ることができる場所です。既存の回答を検索したり、独自の質問をしたりすることで、設計に必要な支援を迅速に得ることができます。

リンクされているコンテンツは、各寄稿者により「現状のまま」提供されるものです。これらはテキサス・インスツルメンツの仕様を構成するものではなく、必ずしもテキサス・インスツルメンツの見解を反映したものではありません。テキサス・インスツルメンツの[使用条件](#)を参照してください。

### 9.3 Trademarks

PowerPAD™ and テキサス・インスツルメンツ E2E™ are trademarks of Texas Instruments.

すべての商標は、それぞれの所有者に帰属します。

### 9.4 静電気放電に関する注意事項



この IC は、ESD によって破損する可能性があります。テキサス・インスツルメンツは、IC を取り扱う際には常に適切な注意を払うことを推奨します。正しい取り扱いおよび設置手順に従わない場合、デバイスを破損するおそれがあります。

ESD による破損は、わずかな性能低下からデバイスの完全な故障まで多岐にわたります。精密な IC の場合、パラメータがわずかに変化するだけで公表されている仕様から外れる可能性があるため、破損が発生しやすくなっています。

### 9.5 用語集

[テキサス・インスツルメンツ用語集](#) この用語集には、用語や略語の一覧および定義が記載されています。

## 10 Revision History

資料番号末尾の英字は改訂を表しています。その改訂履歴は英語版に準じています。

Changes from Revision * (June 2011) to Revision A (February 2024)	Page
ドキュメント全体にわたって表、図、相互参照の採番方法を更新.....	1
「パッケージ情報」表、「ピン構成および機能」、「仕様」、「ESD 定格」、「推奨動作条件」、「熱に関する情報」、「詳細説明」、「概要」、「機能ブロック図」、「機能説明」、「デバイスの機能モード」、「アプリケーションと実装」、「代表的なアプリケーション」、「電源に関する推奨事項」、「レイアウト」、「デバイスおよびドキュメントのサポート」、「メカニカル、パッケージ、および注文情報」セクションを追加 .....	1
プレビューの DWD パッケージとそれに関連する項目を削除.....	1
HSOP のインスタンスを HSOIC に変更 (誤字).....	1
表紙の図で 20kΩ 抵抗のラベルを R <sub>4</sub> から R <sub>3</sub> に変更 (誤字).....	1
Updated <i>Related Products</i> table and renamed to <i>Device Comparison Table</i> .....	2
Changed Operating Junction Temperature to Operating Ambient Temperature and moved to new <i>Recommended Operating Conditions</i> .....	4
Updated format of <i>Electrical Characteristics</i> .....	5
Changed Output current limit range typical value from "±0.4 to ±2.0" to "±0.4 to ±1.9".....	5
Changed current limit flag output typical value for normal operation from 0 to V <sub>-</sub> .....	5
Changed Thermal Shutdown typical value for normal operation from 0 to V <sub>-</sub> .....	5
Changed current limit value range from "0.4A to 1.5A" to "0.4A to 1.6A" in <i>Adjustable Current Limit</i> .....	13

---

- Added text regarding adjustable current limit used to protect the device in *Adjustable Current Limit* ..... 13
- Updated equation terms for consistency..... 13
- Changed  $R_{CL}$  to  $R_{SET}$  in Figure 7-1, *Adjustable Current Limit* ..... 14
- Added text regarding  $I_{FLAG}$  pin to last sentence of *Current Limit Flag* ..... 20
- Added text regarding  $T_{FLAG}$  pin to first paragraph of *Thermal Protection* ..... 20
- Added  $R_1$  and  $R_2$  resistor labels to Figure 8-1, *Basic Noninverting Amplifier* ..... 22
- Changed copper plane size from  $9in^2$  to  $3in^2$  to match Figure 8-2 in *Power Dissipation and Safe Operating Area* ..... 23
- Changed Figure 8-4, *Thermal Resistance vs Circuit Board Copper Area*, to align with *Thermal Information* . 23
- Changed Figure 8-6, *Improved Howland Current Pump*,  $20k\Omega$  resistor from  $R_4$  to  $R_3$  (typo), and deleted footnote..... 25
- Added text to clarify application operation in *Programmable Power Supply* ..... 25
- Moved misplaced junction dot to correct location in Figure 8-10, *Motor-Drive Circuit* ..... 28

---

## 11 Mechanical, Packaging, and Orderable Information

The following pages include mechanical, packaging, and orderable information. This information is the most current data available for the designated devices. This data is subject to change without notice and revision of this document. For browser-based versions of this data sheet, refer to the left-hand navigation.

## 重要なお知らせと免責事項

テキサス・インスツルメンツは、技術データと信頼性データ(データシートを含みます)、設計リソース(リファレンス デザインを含みます)、アプリケーションや設計に関する各種アドバイス、Web ツール、安全性情報、その他のリソースを、欠陥が存在する可能性のある「現状のまま」提供しており、商品性および特定目的に対する適合性の黙示保証、第三者の知的財産権の非侵害保証を含むいかなる保証も、明示的または黙示的にかかわらず拒否します。

これらのリソースは、テキサス・インスツルメンツ製品を使用する設計の経験を積んだ開発者への提供を意図したものです。(1) お客様のアプリケーションに適したテキサス・インスツルメンツ製品の選定、(2) お客様のアプリケーションの設計、検証、試験、(3) お客様のアプリケーションに該当する各種規格や、その他のあらゆる安全性、セキュリティ、規制、または他の要件への確実な適合に関する責任を、お客様のみが単独で負うものとします。

上記の各種リソースは、予告なく変更される可能性があります。これらのリソースは、リソースで説明されているテキサス・インスツルメンツ製品を使用するアプリケーションの開発の目的でのみ、テキサス・インスツルメンツはその使用をお客様に許諾します。これらのリソースに関して、他の目的で複製することや掲載することは禁止されています。テキサス・インスツルメンツや第三者の知的財産権のライセンスが付与されている訳ではありません。お客様は、これらのリソースを自身で使用した結果発生するあらゆる申し立て、損害、費用、損失、責任について、テキサス・インスツルメンツおよびその代理人を完全に補償するものとし、テキサス・インスツルメンツは一切の責任を拒否します。

テキサス・インスツルメンツの製品は、[テキサス・インスツルメンツの販売条件](#)、または [ti.com](https://www.ti.com) やかかるテキサス・インスツルメンツ製品の関連資料などのいずれかを通じて提供する適用可能な条項の下で提供されています。テキサス・インスツルメンツがこれらのリソースを提供することは、適用されるテキサス・インスツルメンツの保証または他の保証の放棄の拡大や変更を意味するものではありません。

お客様がいかなる追加条項または代替条項を提案した場合でも、テキサス・インスツルメンツはそれらに異議を唱え、拒否します。

郵送先住所: Texas Instruments, Post Office Box 655303, Dallas, Texas 75265  
Copyright © 2024, Texas Instruments Incorporated

**PACKAGING INFORMATION**

Orderable Device	Status (1)	Package Type	Package Drawing	Pins	Package Qty	Eco Plan (2)	Lead finish/ Ball material (6)	MSL Peak Temp (3)	Op Temp (°C)	Device Marking (4/5)	Samples
OPA564AQDWPRQ1	ACTIVE	SO PowerPAD	DWP	20	2000	RoHS & Green	NIPDAU	Level-3-260C-168 HR	-40 to 125	OPA564AQ	Samples

(1) The marketing status values are defined as follows:

**ACTIVE:** Product device recommended for new designs.

**LIFEBUY:** TI has announced that the device will be discontinued, and a lifetime-buy period is in effect.

**NRND:** Not recommended for new designs. Device is in production to support existing customers, but TI does not recommend using this part in a new design.

**PREVIEW:** Device has been announced but is not in production. Samples may or may not be available.

**OBSELETE:** TI has discontinued the production of the device.

(2) **RoHS:** TI defines "RoHS" to mean semiconductor products that are compliant with the current EU RoHS requirements for all 10 RoHS substances, including the requirement that RoHS substance do not exceed 0.1% by weight in homogeneous materials. Where designed to be soldered at high temperatures, "RoHS" products are suitable for use in specified lead-free processes. TI may reference these types of products as "Pb-Free".

**RoHS Exempt:** TI defines "RoHS Exempt" to mean products that contain lead but are compliant with EU RoHS pursuant to a specific EU RoHS exemption.

**Green:** TI defines "Green" to mean the content of Chlorine (Cl) and Bromine (Br) based flame retardants meet JS709B low halogen requirements of <=1000ppm threshold. Antimony trioxide based flame retardants must also meet the <=1000ppm threshold requirement.

(3) MSL, Peak Temp. - The Moisture Sensitivity Level rating according to the JEDEC industry standard classifications, and peak solder temperature.

(4) There may be additional marking, which relates to the logo, the lot trace code information, or the environmental category on the device.

(5) Multiple Device Markings will be inside parentheses. Only one Device Marking contained in parentheses and separated by a "-" will appear on a device. If a line is indented then it is a continuation of the previous line and the two combined represent the entire Device Marking for that device.

(6) Lead finish/Ball material - Orderable Devices may have multiple material finish options. Finish options are separated by a vertical ruled line. Lead finish/Ball material values may wrap to two lines if the finish value exceeds the maximum column width.

**Important Information and Disclaimer:**The information provided on this page represents TI's knowledge and belief as of the date that it is provided. TI bases its knowledge and belief on information provided by third parties, and makes no representation or warranty as to the accuracy of such information. Efforts are underway to better integrate information from third parties. TI has taken and continues to take reasonable steps to provide representative and accurate information but may not have conducted destructive testing or chemical analysis on incoming materials and chemicals. TI and TI suppliers consider certain information to be proprietary, and thus CAS numbers and other limited information may not be available for release.

In no event shall TI's liability arising out of such information exceed the total purchase price of the TI part(s) at issue in this document sold by TI to Customer on an annual basis.

**OTHER QUALIFIED VERSIONS OF OPA564-Q1 :**

- Catalog : [OPA564](#)

NOTE: Qualified Version Definitions:

- Catalog - TI's standard catalog product

**TAPE AND REEL INFORMATION**

**QUADRANT ASSIGNMENTS FOR PIN 1 ORIENTATION IN TAPE**

\*All dimensions are nominal

Device	Package Type	Package Drawing	Pins	SPQ	Reel Diameter (mm)	Reel Width W1 (mm)	A0 (mm)	B0 (mm)	K0 (mm)	P1 (mm)	W (mm)	Pin1 Quadrant
OPA564AQDWPRQ1	SO PowerPAD	DWP	20	2000	330.0	24.4	10.8	13.3	2.7	12.0	24.0	Q1

**TAPE AND REEL BOX DIMENSIONS**



\*All dimensions are nominal

Device	Package Type	Package Drawing	Pins	SPQ	Length (mm)	Width (mm)	Height (mm)
OPA564AQDWPRQ1	SO PowerPAD	DWP	20	2000	350.0	350.0	43.0

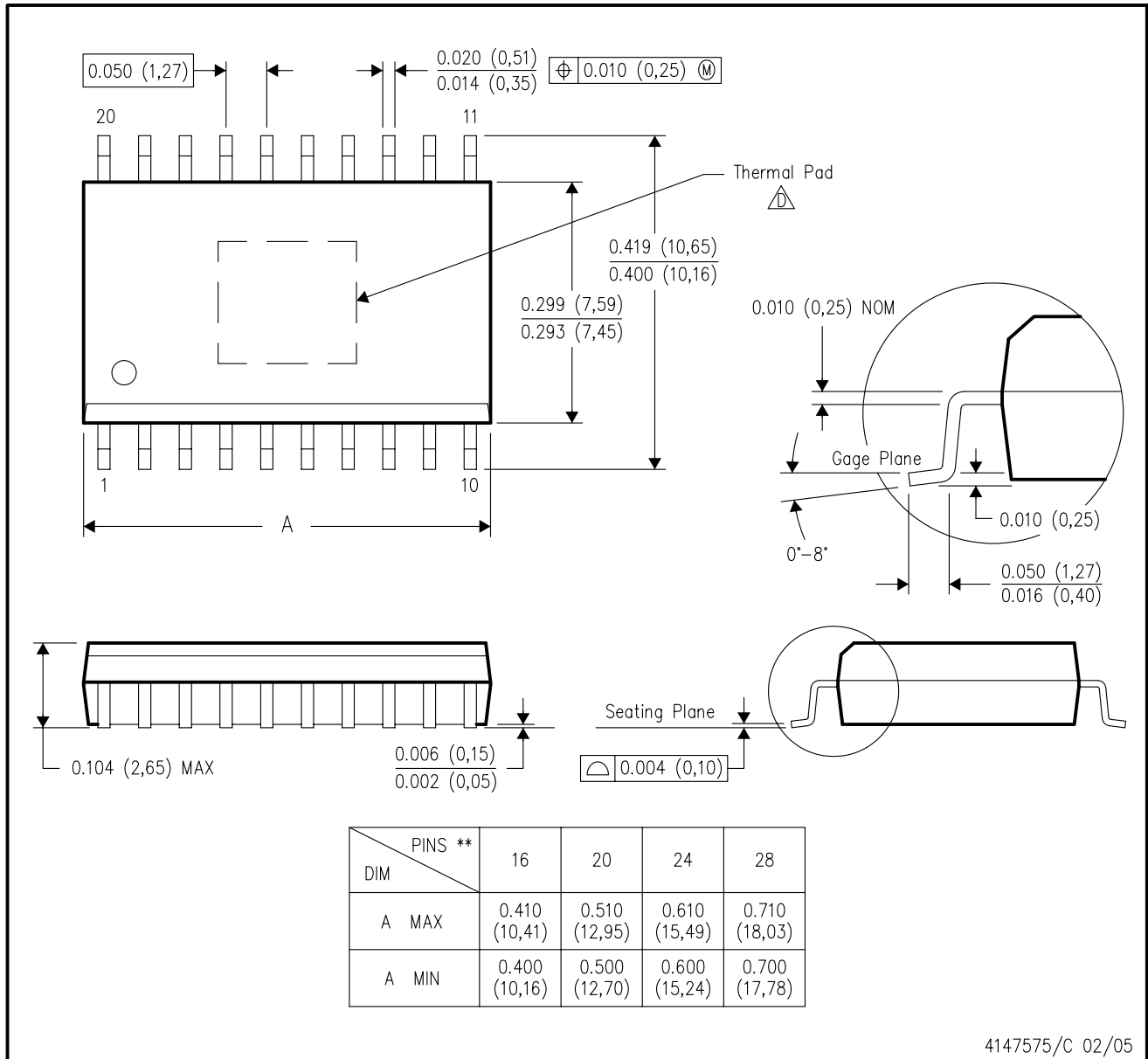

DWP (R-PDSO-G\*\*) 20 PINS SHOWN

PowerPAD™ PLASTIC SMALL-OUTLINE PACKAGE



- NOTES:
- A. All linear dimensions are in inches (millimeters).
  - B. This drawing is subject to change without notice.
  - C. Body dimensions do not include mold flash or protrusion not to exceed 0.006 (0,15).
- △ This package is designed to be soldered to a thermal pad on the board. Refer to Technical Brief, PowerPAD Thermally Enhanced Package, Texas Instruments Literature No. SLMA002 for information regarding recommended board layout. This document is available at [www.ti.com](http://www.ti.com) <<http://www.ti.com>>. See the product data sheet for details regarding the exposed thermal pad dimensions.

PowerPAD is a trademark of Texas Instruments.

## THERMAL PAD MECHANICAL DATA

DWP (R-PDSO-G20)

PowerPAD™ PLASTIC SMALL OUTLINE

### THERMAL INFORMATION

This PowerPAD™ package incorporates an exposed thermal pad that is designed to be attached to a printed circuit board (PCB). The thermal pad must be soldered directly to the PCB. After soldering, the PCB can be used as a heatsink. In addition, through the use of thermal vias, the thermal pad can be attached directly to the appropriate copper plane shown in the electrical schematic for the device, or alternatively, can be attached to a special heatsink structure designed into the PCB. This design optimizes the heat transfer from the integrated circuit (IC).

For additional information on the PowerPAD package and how to take advantage of its heat dissipating abilities, refer to Technical Brief, PowerPAD Thermally Enhanced Package, Texas Instruments Literature No. SLMA002 and Application Brief, PowerPAD Made Easy, Texas Instruments Literature No. SLMA004. Both documents are available at [www.ti.com](http://www.ti.com).

The exposed thermal pad dimensions for this package are shown in the following illustration.

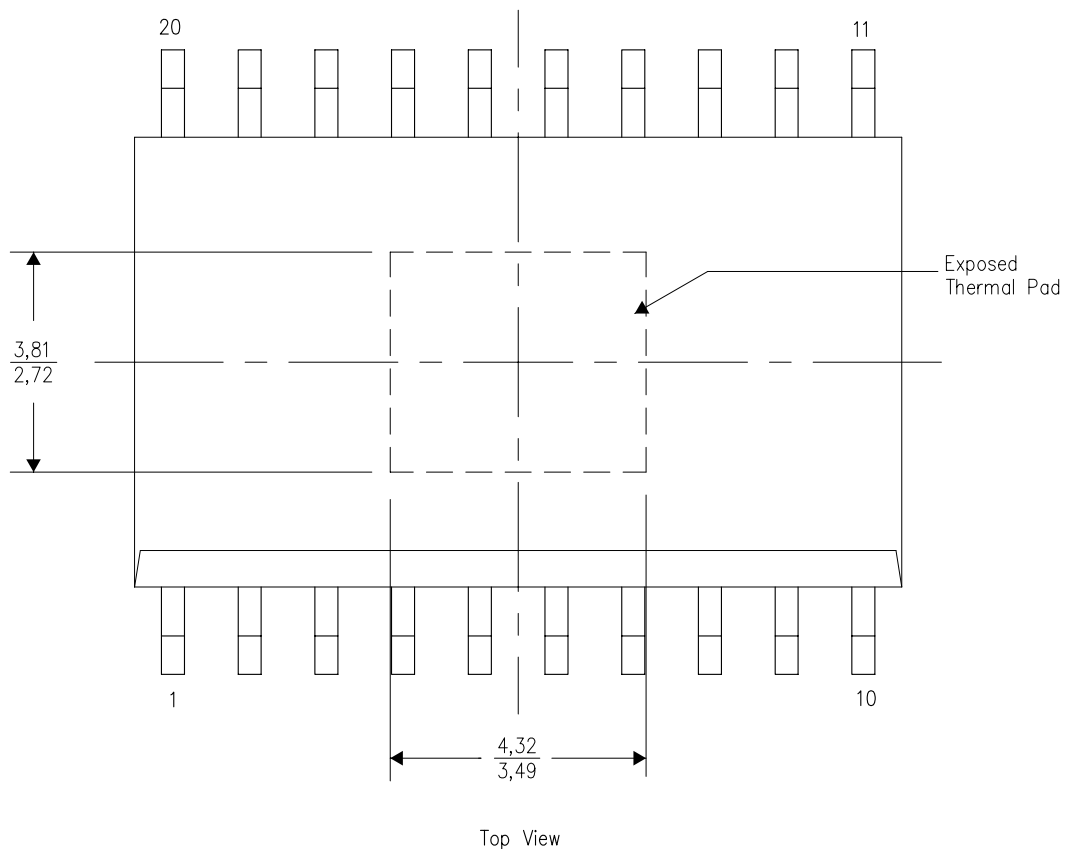

Exposed Thermal Pad Dimensions

4206325-2/E 12/10

NOTE: A. All linear dimensions are in millimeters

## 重要なお知らせと免責事項

TI は、技術データと信頼性データ(データシートを含みます)、設計リソース(リファレンス・デザインを含みます)、アプリケーションや設計に関する各種アドバイス、Web ツール、安全性情報、その他のリソースを、欠陥が存在する可能性のある「現状のまま」提供しており、商品性および特定目的に対する適合性の黙示保証、第三者の知的財産権の非侵害保証を含むいかなる保証も、明示的または黙示的にかかわらず拒否します。

これらのリソースは、TI 製品を使用する設計の経験を積んだ開発者への提供を意図したものです。(1) お客様のアプリケーションに適した TI 製品の選定、(2) お客様のアプリケーションの設計、検証、試験、(3) お客様のアプリケーションに該当する各種規格や、その他のあらゆる安全性、セキュリティ、規制、または他の要件への確実な適合に関する責任を、お客様のみが単独で負うものとし、

上記の各種リソースは、予告なく変更される可能性があります。これらのリソースは、リソースで説明されている TI 製品を使用するアプリケーションの開発の目的でのみ、TI はその使用をお客様に許諾します。これらのリソースに関して、他の目的で複製することや掲載することは禁止されています。TI や第三者の知的財産権のライセンスが付与されている訳ではありません。お客様は、これらのリソースを自身で使用した結果発生するあらゆる申し立て、損害、費用、損失、責任について、TI およびその代理人を完全に補償するものとし、TI は一切の責任を拒否します。

TI の製品は、[TI の販売条件](#)、または [ti.com](#) やかかる TI 製品の関連資料などのいずれかを通じて提供する適用可能な条項の下で提供されています。TI がこれらのリソースを提供することは、適用される TI の保証または他の保証の放棄の拡大や変更を意味するものではありません。

お客様がいかなる追加条項または代替条項を提案した場合でも、TI はそれらに異議を唱え、拒否します。

郵送先住所 : Texas Instruments, Post Office Box 655303, Dallas, Texas 75265  
Copyright © 2024, Texas Instruments Incorporated