

## LMG365xR035 ドライバと保護機能を内蔵した 650V、35mΩ GaN FET

### 1 特長

- ゲートドライバ内蔵、650V、35mΩ の GaN 電力 FET
  - >200V/ns の FET ホールド オフ
  - 調整可能なスルーレートによるスイッチングパフォーマンスの最適化と EMI の軽減
    - 10V/ns から 100V/ns の有効化スルーレート
    - 10V/ns からフルスピードの有効化スルーレート
  - 電源ピンと入力ロジックピンの 9V から 26V の電圧範囲で動作します
- 堅牢な保護
  - サイクル単位の過電流保護と応答時間 300ns 未満のラッチ付き短絡保護
  - ハードスイッチング中のサージ耐性: 720V
  - 内部過熱および UVLO 監視機能による自己保護
- サーマルパッド付きの 9.8mm × 11.6mm TOLL パッケージ

### 2 アプリケーション

- 商用ネットワークとサーバーの電源
- 商用テレコム整流器
- ソーラーインバータと産業用モータードライブ
- 無停電電源

### 3 概要

ドライバと保護機能を内蔵した LMG365xR035 GaN FET は、スイッチモードパワーコンバータを対象としています。このデバイスを使うと、設計者は比類ない電力密度と効率を実現できます。

調整可能なゲートドライブ強度により、独立な有効化と最大限無効化スルーレートの制御が可能で、EMI のアクティブ制御とスイッチング性能の最適化に使用できます。有効化スルーレートは 100V/ns<sup>10</sup> から V/ns まで変動する可能性があります。負荷電流の大きさに基づいて 10V/ns の範囲で無効化スルーレートの最大値に制限することができます。保護機能として、低電圧誤動作防止 (UVLO)、サイクル単位の電流制限、短絡保護、および過熱保護が搭載されています。LMG3651R035 は、外部デジタルアソレータへの電力供給に使用できる LDO5V ピンで 5V LDO 出力を供給します。LMG3656R035 は、ゼロ電圧検出 (ZVD) 機能を備えており、ゼロ電圧スイッチングが発生したとき ZVD ピンからパルスを出力します。LMG3657R035 は、ドレイン-ソース間電流が負であり、ゼロクロスポイント検出時に Low に遷移すると ZCD ピンを High に設定するゼロ電流検出 (ZCD) 機能を備えています。

#### パッケージ情報

部品番号	パッケージ <sup>(1)</sup>	パッケージサイズ <sup>(2)</sup>
LMG365xR035	KLA (TOLL, 9)	9.8 mm × 11.6mm

- 供給されているすべてのパッケージについては、[セクション 12](#) を参照してください。
- パッケージサイズ (長さ × 幅) は公称値で、該当する場合はピンも含まれます。

#### 製品情報

部品番号 <sup>(1)</sup>	ピン 7
LMG3650R035	GND
LMG3651R035	LDO5V
LMG3656R035	ZVD
LMG3657R035	ZCD

- [製品比較表](#)を参照してください。

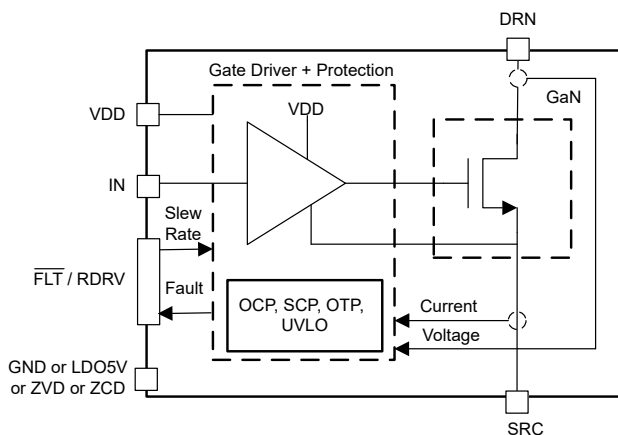

概略ブロック図



## Table of Contents

1 特長.....	1	8.3 Feature Description.....	15
2 アプリケーション.....	1	8.4 Device Functional Modes.....	22
3 概要.....	1	<b>9 Application and Implementation.....</b>	<b>23</b>
4 Device Comparison.....	3	9.1 Application Information.....	23
5 Pin Configuration and Functions.....	4	9.2 Typical Application.....	24
6 Specifications.....	5	9.3 Power Supply Recommendations.....	31
6.1 Absolute Maximum Ratings.....	5	9.4 Layout.....	32
6.2 ESD Ratings.....	5	<b>10 Device and Documentation Support.....</b>	<b>36</b>
6.3 Recommended Operating Conditions.....	5	10.1 ドキュメントの更新通知を受け取る方法.....	36
6.4 Thermal Information.....	5	10.2 サポート・リソース.....	36
6.5 Electrical Characteristics.....	6	10.3 Trademarks.....	36
6.6 Switching Characteristics.....	7	10.4 静電気放電に関する注意事項.....	36
7 Parameter Measurement Information.....	9	10.5 用語集.....	36
7.1 Switching Parameters.....	9	<b>11 Revision History.....</b>	<b>36</b>
8 Detailed Description.....	12	<b>12 Mechanical, Packaging, and Orderable Information.....</b>	<b>36</b>
8.1 Overview.....	12	12.1 Tape and Reel Information.....	40
8.2 Functional Block Diagram.....	12		

## 4 Device Comparison

表 4-1. Device Comparison

DEVICE NAME	$R_{DS(on)}$	Pin 7
LMG3650R025	25mΩ	GND
LMG3651R025		LDO5V
LMG3656R025		ZVD
LMG3657R025		ZCD
LMG3650R035	35mΩ	GND
LMG3651R035		LDO5V
LMG3656R035		ZVD
LMG3657R035		ZCD
LMG3650R070	70mΩ	GND
LMG3651R070		LDO5V
LMG3656R070		ZVD
LMG3657R070		ZCD

## 5 Pin Configuration and Functions

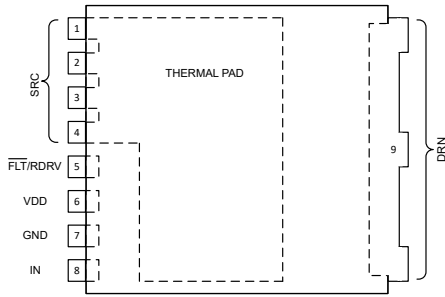

5-1. LMG3650R035, TOLL Package (Top View)

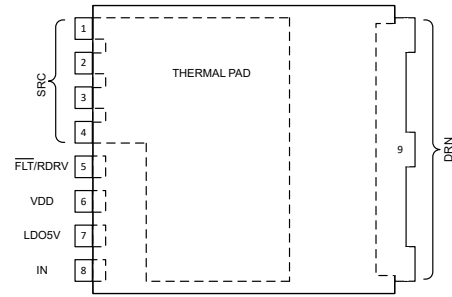

5-2. LMG3651R035, TOLL Package (Top View)

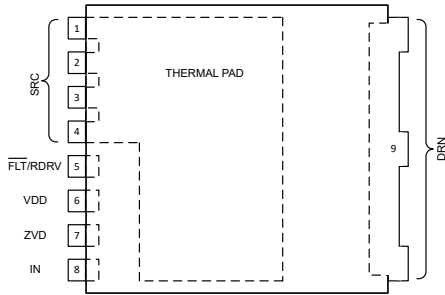

5-3. LMG3656R035, TOLL Package (Top View)

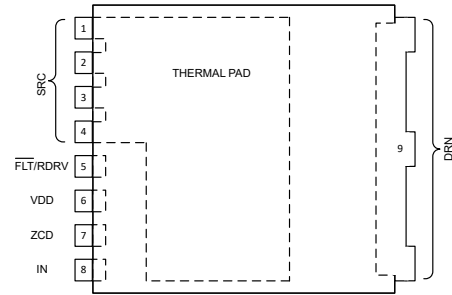

5-4. LMG3657R035, TOLL Package (Top View)

表 5-1. Pin Functions

NAME	PIN				TYPE (1)	DESCRIPTION
	LMG3650 R035	LMG3651 R035	LMG3656 R035	LMG3657 R035		
SRC	1 - 4	1 - 4	1 - 4	1 - 4	P	GaN FET source.
FLT/RDRV	5	5	5	5	O, I	Fault monitoring and drive strength selection pin. Connect a resistor from this pin to GND to set the turn-on drive strength. Connect a resistor in series with capacitor from this pin to GND to set the turn-off drive strength. Slew rates are set one time at the time of power up, then the pin is used for fault monitoring.
VDD	6	6	6	6	P	Device input supply
GND	7	—	—	—	G	Signal ground. Internally connected to SRC, and THERMAL PAD.
LDO5V	—	7	—	—	P	5V LDO output for external digital isolator.
ZVD	—	—	7	—	O	Push-pull digital output that provides zero-voltage detection signal to indicate if device achieves zero-voltage switching in current switching cycle.
ZCD	—	—	—	7	O	Push-pull digital output that sets ZCD pin high when the drain-to-source current is negative and transitions to low upon detecting the zero-crossing point.
IN	8	8	8	8	I	CMOS compatible non inverting input used to turn the FET on and off
DRN	9	9	9	9	P	GaN FET drain
THERMAL PAD	—	—	—	—	—	Thermal pad.

(1) I = Input, O = Output, I/O = Input or Output, G = Ground, P = Power.

## 6 Specifications

### 6.1 Absolute Maximum Ratings

Unless otherwise noted: voltages are respect to GND/SRC<sup>(1)</sup>

		MIN	MAX	UNIT
V <sub>DS</sub>	Drain-source voltage, FET off		650	V
V <sub>DS(surge)</sub>	Drain-source voltage, surge condition, FET off		720	V
V <sub>DS(tr)(surge)</sub>	Drain-source transient ringing peak voltage, surge condition, FET off		800	V
Pin voltage	VDD	-0.5	28	V
	IN	-0.5	28	V
	FLT/RDRV	-0.5	5.5	V
I <sub>D</sub>	Peak drain current, FET on		TBD	A
I <sub>D(pulse)</sub>	Pulse drain current, FET on, t <sub>p</sub> < 10μs.	-68	Internally Limited	A
T <sub>J</sub>	Operating junction temperature	-40	175	°C
T <sub>stg</sub>	Storage temperature	-65	150	°C

- (1) Operation outside the Absolute Maximum Ratings may cause permanent device damage. Absolute Maximum Ratings do not imply functional operation of the device at these or any other conditions beyond those listed under Recommended Operating Conditions. If used outside the Recommended Operating Conditions but within the Absolute Maximum Ratings, the device may not be fully functional, and this may affect device reliability, functionality, performance, and shorten the device lifetime.

### 6.2 ESD Ratings

			VALUE	UNIT
V <sub>(ESD)</sub>	Electrostatic discharge	Human body model (HBM), per ANSI/ESDA/JEDEC JS-001 <sup>(1)</sup>	±2000	V
		Charged-device model (CDM), per ANSI/ESDA/JEDEC JS-002 <sup>(2)</sup>	±500	

- (1) JEDEC document JEP155 states that 500-V HBM allows safe manufacturing with a standard ESD control process.  
(2) JEDEC document JEP157 states that 250-V CDM allows safe manufacturing with a standard ESD control process.

### 6.3 Recommended Operating Conditions

Unless otherwise noted: voltages are respect to GND/SRC

		MIN	NOM	MAX	UNIT
Supply voltage	VDD	9		26	V
Input voltage	IN	0		26	V
I <sub>D</sub>	Drain current, FET on			20	A
R <sub>1</sub>	Resistance from external turn-on slew rate control resistor between FLT/RDRV to GND	29.4		open	kΩ
R <sub>2</sub>	Resistance and capacitance from external turn-off slew rate control series resistor	2		open	kΩ
C <sub>2</sub>	and capacitor configuration between FLT/RDRV to GND	0		680	pF

### 6.4 Thermal Information

THERMAL METRIC <sup>(1)</sup>		KLA (TOLL)		UNIT
		9 PINS		
R <sub>θJC(bot)</sub>	Junction-to-case (bottom) thermal resistance	0.38		°C/W

- (1) For more information about traditional and new thermal metrics, see the [Semiconductor and IC Package Thermal Metrics](#) application report.

## 6.5 Electrical Characteristics

Unless otherwise noted: voltage, resistance, capacitance, and inductance are respect to GND/SRC;  $-40^{\circ}\text{C} \leq T_J \leq 150^{\circ}\text{C}$ ; VDD = 12V; FLT/RDRV resistances R1 & R2 are open

PARAMETER		TEST CONDITIONS	MIN	TYP	MAX	UNIT
<b>GAN POWER FET</b>						
R <sub>DS(on)</sub>	Drain-source on resistance	T <sub>J</sub> = 25°C, I <sub>L</sub> = 16A		35	55	mΩ
		T <sub>J</sub> = 150°C, I <sub>L</sub> = 16A		80		mΩ
V <sub>SD</sub>	Source-drain third-quadrant voltage	T <sub>J</sub> = 25°C, I <sub>SD</sub> = 0.1A		1.8		V
		T <sub>J</sub> = 150°C, I <sub>SD</sub> = 0.1A		1.8		V
		T <sub>J</sub> = 25°C, I <sub>SD</sub> = 20A		2.9		V
		T <sub>J</sub> = 150°C, I <sub>SD</sub> = 20A		3		V
I <sub>DSS</sub>	Drain leakage current	T <sub>J</sub> = 25°C, V <sub>DS</sub> = 650V		TBD		μA
		T <sub>J</sub> = 150°C, V <sub>DS</sub> = 650V		TBD		μA
Q <sub>OSS</sub>	Output charge	V <sub>DS</sub> = 400V		125		nC
C <sub>OSS</sub>	Output capacitance	V <sub>DS</sub> = 400V		173		pF
E <sub>OSS</sub>	Output capacitance stored energy	V <sub>DS</sub> = 400V		15		μJ
C <sub>OSS(tr)</sub>	Time related effective output capacitance	V <sub>DS</sub> = 400V		255		pF
C <sub>OSS(er)</sub>	Energy related effective output capacitance	V <sub>DS</sub> = 400V		200		pF
Q <sub>RR</sub>	Reverse recovery charge			0		nC
<b>OVERCURRENT AND SHORT-CIRCUIT PROTECTIONS</b>						
I <sub>T(OC)</sub>	Overcurrent protection threshold		26	29	32	A
V <sub>T(Idsat)</sub>	Saturation current detection - threshold voltage		8.7	9	9.6	V
<b>OVERTEMPERATURE PROTECTION</b>						
T <sub>T+</sub>	Temperature fault - positive-going threshold temperature			190		°C
T <sub>T-</sub>	Temperature fault - negative-going threshold temperature			175		°C
T <sub>T(hyst)</sub>	Temperature fault - threshold temperature hysteresis			20		°C
<b>IN</b>						
V <sub>IN,IT+</sub>	Positive-going input threshold voltage		1.7	2	2.45	V
V <sub>IN,IT-</sub>	Negative-going input threshold voltage		0.7	1	1.3	V
V <sub>IN,IT(hyst)</sub>	Input threshold voltage hysteresis			1		V
R <sub>PDN</sub>	Pull-down input resistance		115	150	185	kΩ
<b>FLT/RDRV</b>						
V <sub>OL</sub>	Low-level output voltage	Output sink 8mA		0.2	0.4	V
V <sub>OH</sub>	High-level output voltage	Output source 8mA	4.6	4.8		V
<b>VDD</b>						
I <sub>VDD(ON)</sub>	Quiescent current when FET is ON	IN=1		1.9	11.5	mA
I <sub>VDD(OFF)</sub>	Quiescent current when FET is OFF	IN=0		0.7	1.1	mA
I <sub>VDD(op)</sub>	Operating current at 140 kHz	f <sub>sw</sub> = 140kHz, V <sub>bus</sub> = 400V, Hard-switched, 50% duty cycle.		3.5	6.5	mA
V <sub>VDD, T+ (UVLO)</sub>	UVLO- positive-going threshold voltage		8.1	8.5	8.9	V
V <sub>VDD, T- (UVLO)</sub>	UVLO- negative-going threshold voltage		7.6	8	8.4	V
V <sub>VDD, T (hyst)</sub>	UVLO- threshold voltage hysteresis			0.5		V

## 6.6 Switching Characteristics

Unless otherwise noted: voltage, resistance, capacitance, and inductance are respect to GND/SRC;  $-40^{\circ}\text{C} \leq T_J \leq 150^{\circ}\text{C}$ ;  $V_{DD} = 12\text{V}$ ; FLT/RDRV resistances R1 & R2 are open

PARAMETER		TEST CONDITIONS	MIN	TYP	MAX	UNIT
<b>SWITCHING TIMES</b>						
$t_{d(on)}$	Turn-on delay time	From $V_{IN} > V_{IN,IT+}$ to $V_{DS} < 320\text{V}$ , $V_{BUS} = 400\text{V}$ , $L_{HB}$ current = 0A, 100V/ns		30	45	ns
$t_{ir(on)}$	Turn-on current rise time + delay time	From $V_{IN} > V_{IN,IT+}$ to $V_{DS} < 320\text{V}$ , $V_{BUS} = 400\text{V}$ , $L_{HB}$ current = 10A, 100V/ns		35	60	ns
$t_{vf(on)}$	Turn-on voltage falling time	From $V_{DS} < 320\text{V}$ to $V_{DS} < 80\text{V}$ , $V_{BUS} = 400\text{V}$ , $L_{HB}$ current = 10A, 100V/ns	1	2.3	3	ns
$t_{vf\_peak(on)}$	Turn-on slew rate	dv/dt when $V_{DS} = 200\text{V}$ , $V_{BUS} = 400\text{V}$ , $L_{HB}$ current = 10A, 100V/ns	90	115	150	V/ns
	Pulse width distortion	slew-rate setting at 100V/ns			20	ns
	Minimum input pulse changing the output L-H-L	slew-rate setting at 100V/ns such that SW crosses 200V			50	ns
$t_{d(off)}$	Turn-off delay time at full speed	From $V_{IN} < 2.5\text{V}$ to $V_{DS} \geq 10\text{V}$ . $V_{BUS} = 400\text{V}$ , $I_L = 34\text{A}$ , fastest or full turn-off speed.	12	17	35	ns
$t_{vr(off)}$	Turn-off voltage rise time at full speed	From $V_{DS} \geq 20\text{V}$ to $V_{DS} \geq 380\text{V}$ . $V_{BUS} = 400\text{V}$ , $I_L = 34\text{A}$ , fastest or full turn-off speed.	3	4.5	7	ns
<b>STARTUP TIMES</b>						
$T_{DRV\_START}$	Driver startup delay	From Driver supply crossing UVLO to switch turning on if IN is high.		35	65	$\mu\text{s}$
<b>FAULT TIMES</b>						
$t_{off(OC)}$	Overcurrent fault FET turn-off time, FET on before overcurrent	From $I_D \geq I_{T(OC)}$ to $V_{ds} > 10\text{V}$ , di/dt = 100A/ $\mu\text{s}$ , in the fastest turn-off speed		370	480	ns
$t_{off(OC\_ON)}$	Overcurrent total on time, turn-on into overcurrent.	From $V_{ds} \leq 10\text{V}$ to $V_{ds} \geq 10\text{V}$ , turning on at 110% of OC level, at 100 V/ns turn-on slew rate and fastest turn-off speed.		420	580	ns
$t_{off\_cur(SC\_ON)}$	SC on time measured through drain current	From LS $I_{ds} > 50\text{A}$ to $I_{ds} < 50\text{A}$ , at 100 V/ns turn-on slew rate in a half-bridge configuration.	100		500	ns
$t_{off\_cur(SC)}$	SC response time with source current measurement	From LS $V_{ds} > 9\text{V}$ to LS $I_{ds} < 50\text{A}$ , at 100 V/ns turn-on slew rate in a half-bridge configuration. .			300	ns
	Latched-Fault reset time	Time required to hold both gate driver input low to clear latched-fault	300	380	450	$\mu\text{s}$
<b>ZCD/ZVD</b>						
	ZCD delay	Current crossing zero (low to high) to ZCD output pulse di/dt = 0.03A/ns	12	25	40	ns
	ZVD delay	In rising to ZVD output pulse. 100V/ns turn-on speed.	13	20	50	ns
$t_{WD\_ZVD}$	ZVD pulse width	$V_{bus} = 10\text{V}$ , $I_L = 5\text{A}$ , measure ZVD pulse width	90	120	170	ns

## 6.6 Switching Characteristics (続き)

Unless otherwise noted: voltage, resistance, capacitance, and inductance are respect to GND/SRC;  $-40^{\circ}\text{C} \leq T_J \leq 150^{\circ}\text{C}$ ;  $V_{DD} = 12\text{V}$ ; FLT/RDRV resistances R1 & R2 are open

PARAMETER		TEST CONDITIONS	MIN	TYP	MAX	UNIT
	ZVD sensing time	Sensing time to fet turn on (100V/ns). IL=2A		11	25	ns



## 7 Parameter Measurement Information

### 7.1 Switching Parameters

Figure 7-1 shows the circuit used to measure most switching parameters. The top device in this circuit is used to recirculate the inductor current and functions in third-quadrant mode only. The bottom device is the active device that turns on to increase the inductor current to the desired test current. The bottom device is then turned off and on to create switching waveforms at a specific inductor current. Both the drain current (at the source) and the drain-source voltage is measured. Figure 7-2 shows the specific timing measurement. TI recommends to use the half-bridge as a double pulse tester. Excessive third-quadrant operation can overheat the top device.

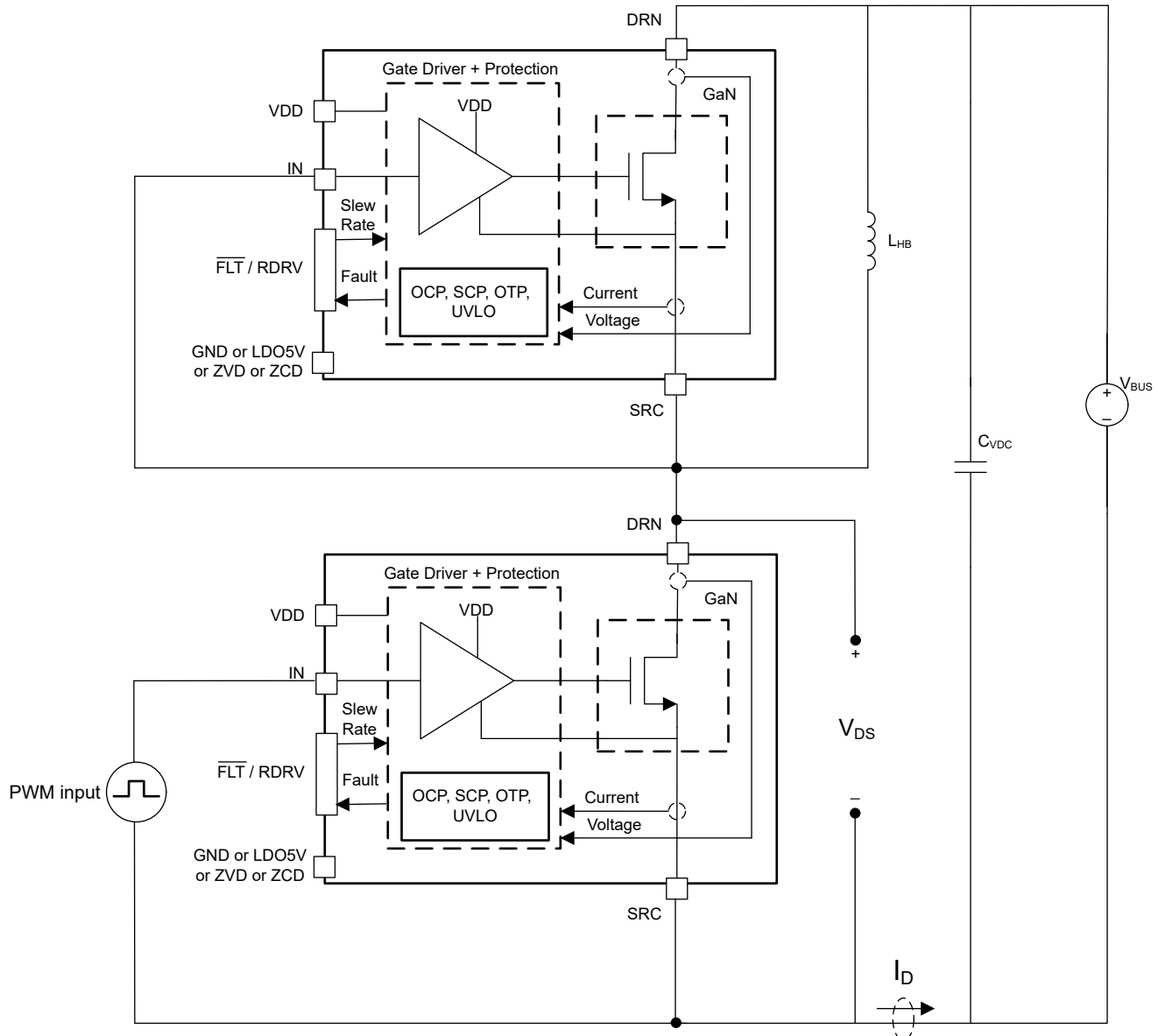

Figure 7-1. Circuit Used to Determine Switching Parameters

ADVANCE INFORMATION



図 7-2. Measurement to Determine Propagation Delays and Slew Rates

ADVANCE INFORMATION

### 7.1.1 Turn-On Times

The turn-on transition has two timing components: turn-on delay time, and turn-on voltage fall time. The turn-on delay time is from when IN goes high to when the drain-source voltage falls 20% below the bus voltage. The turn-on voltage fall time is from when drain-source voltage falls 20% below the bus voltage to when the drain-source voltage falls 80% below the bus voltage. Note that the turn-on timing components are a function of the turn-on drive strength resistance RDRV\_on connected to the  $\overline{\text{FLT}}/\text{RDRV}$  pin.

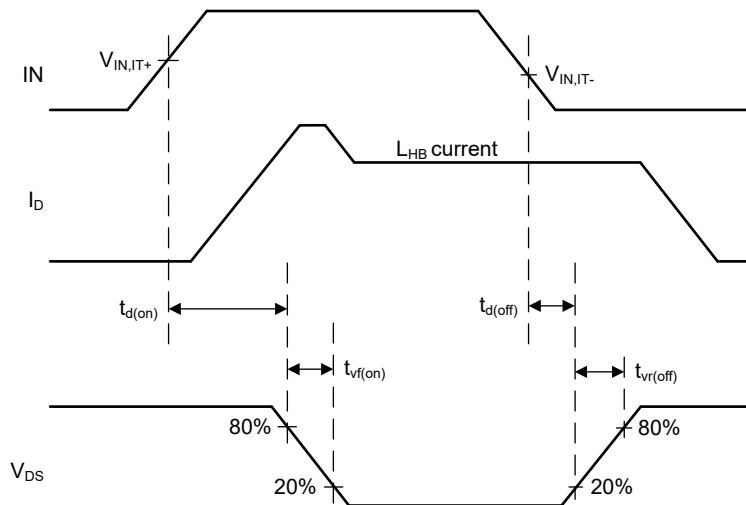
### 7.1.2 Turn-Off Times

The turn-off transition has two timing components: turn-off delay time, and turn-off voltage rise time. The turn-off delay time is from when IN goes low to when the drain-source voltage rises to 20% of the bus voltage. The turn-off voltage rise time is from when the drain-source voltage rises from 20% of the bus voltage to when the drain-source voltage to 80% of the bus voltage. Note that the turn-off timing components are dependent on the  $I_{\text{LHB}}$  load current, however LMG365xR035 also features the ability to limit turn-off drive strength. When the drain-to-source current is sufficiently high and the turn-off drive strength is limited, the timing components become dependent on the programming resistors RDRV\_on, RDRV\_off, and capacitance CDRV\_off connected to the  $\overline{\text{FLT}}/\text{RDRV}$  pin.

### 7.1.3 Drain-Source Turn-On and Turn-off Slew Rate

The drain-source turn-on and turn-off slew rate is measured on  $V_{\text{DS}}$  around the midpoint of the bus voltage, with units in volts per nanosecond. The resistors RDRV\_on, RDRV\_off, and capacitance CDRV\_off connected to the  $\overline{\text{FLT}}/\text{RDRV}$  pin is used to program the turn-on slew rate and limit the turn-off slew rate.

### 7.1.4 Zero-Voltage Detection Times (LMG3656R035 only)

図 7-3 defines the switching timings related to the zero-voltage detection (ZVD) block, and the device's drain-to-source voltage, IN pin signal, and ZVD output signals are demonstrated. When the device achieves zero-voltage switching (ZVS), the ZVD pin outputs a pulse-signal with width  $T_{\text{WD\_ZVD}}$ , and the delay time in between IN pin's rising edge and ZVD pulse's rising edge is defined as  $T_{\text{DL\_ZVD}}$ . A certain third quadrant conduction time is required to allow the device detecting a zero-voltage switching, and  $T_{\text{3rd\_ZVD}}$  indicates this timing. See the [セクション 8.3.8](#) section for more information about the ZVD timing parameters.

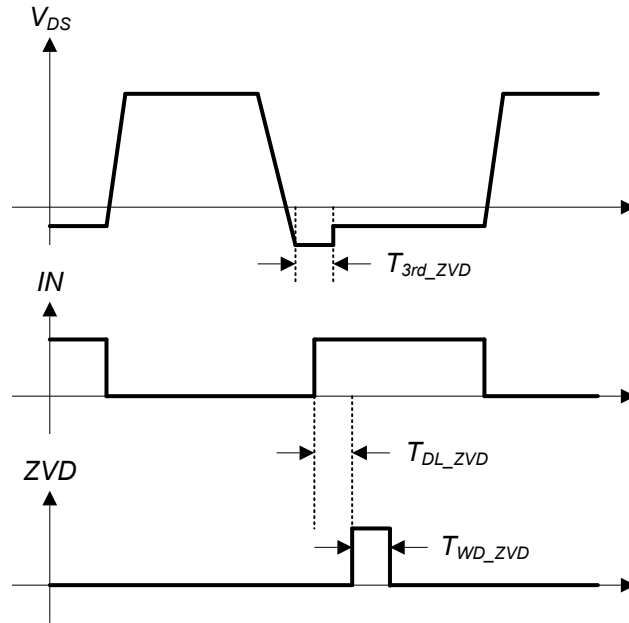

☒ 7-3. ZVD Timing Specifications

## 8 Detailed Description

### 8.1 Overview

The LMG365xR035 is a high-performance power GaN device with integrated gate driver. The GaN device offers zero reverse recovery and ultra-low output capacitance, which enables high efficiency in bridge-based topologies.

The integrated driver ensures the device stays off for high drain slew rates. The integrated driver protects the GaN device from overcurrent, short-circuit, overtemperature, VDD undervoltage, and a high-impedance RDRV pin.

Unlike Si MOSFETs, GaN devices do not have a p-n junction from source to drain and thus have no reverse recovery charge. However, GaN devices still conduct from source to drain similar to a p-n junction body diode, but with higher voltage drop and higher conduction loss. Therefore, source-to-drain conduction time must be minimized while the LMG365xR035 GaN FET is turned off.

### 8.2 Functional Block Diagram

#### 8.2.1 LMG3650R035 Functional Block Diagram

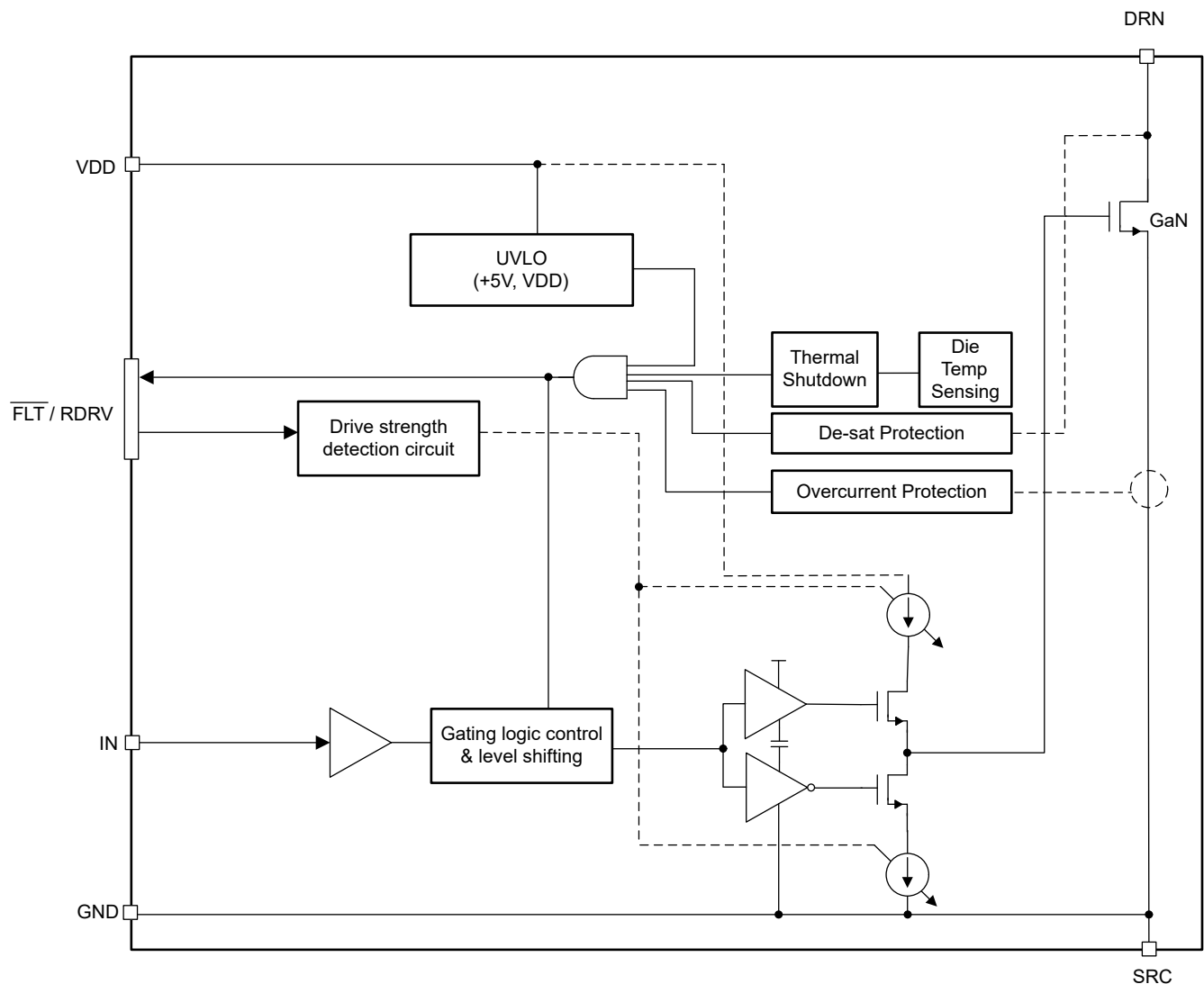

### 8.2.2 LMG3651R035 Functional Block Diagram

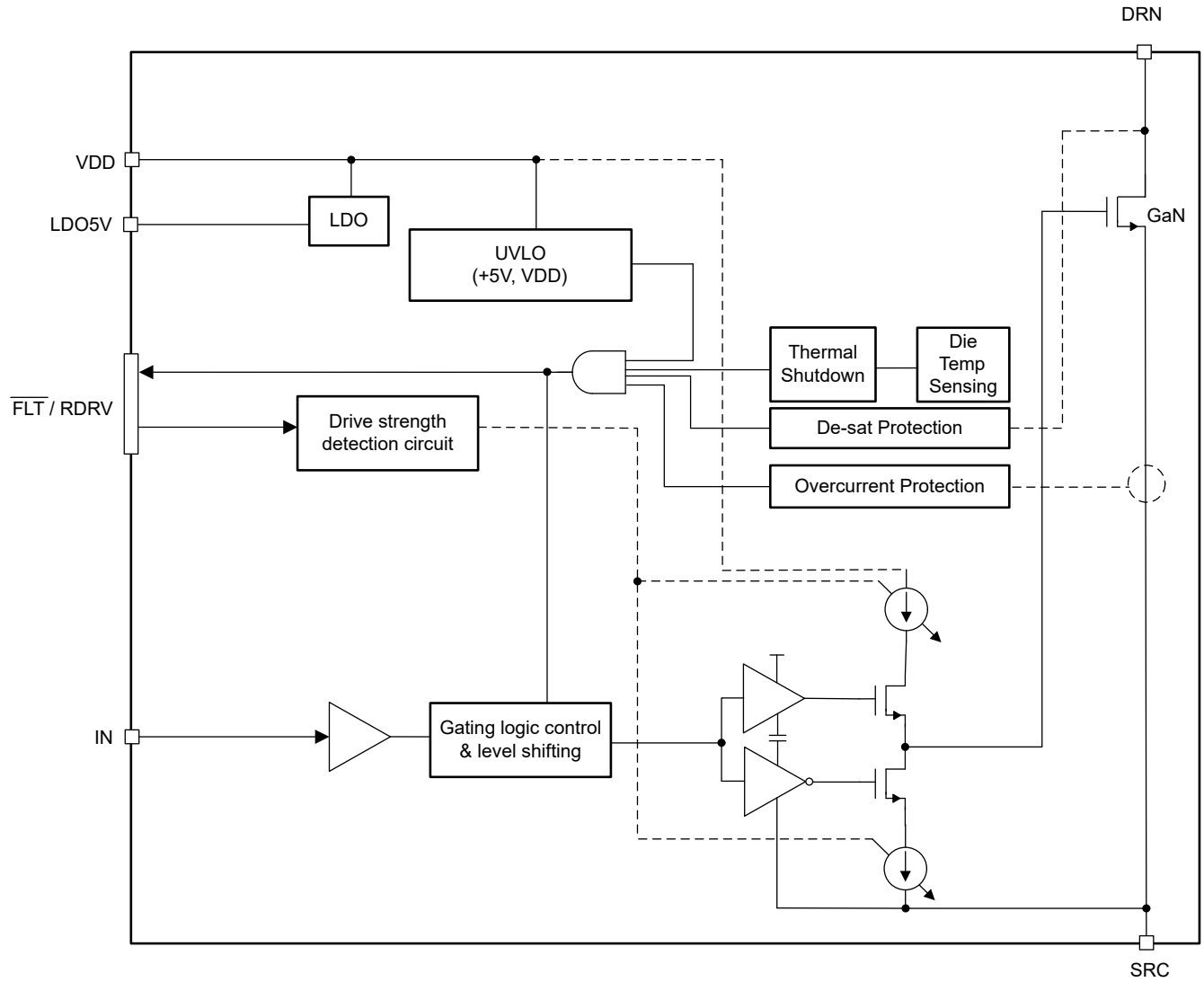

ADVANCE INFORMATION

### 8.2.3 LMG3656R035 Functional Block Diagram

ADVANCE INFORMATION

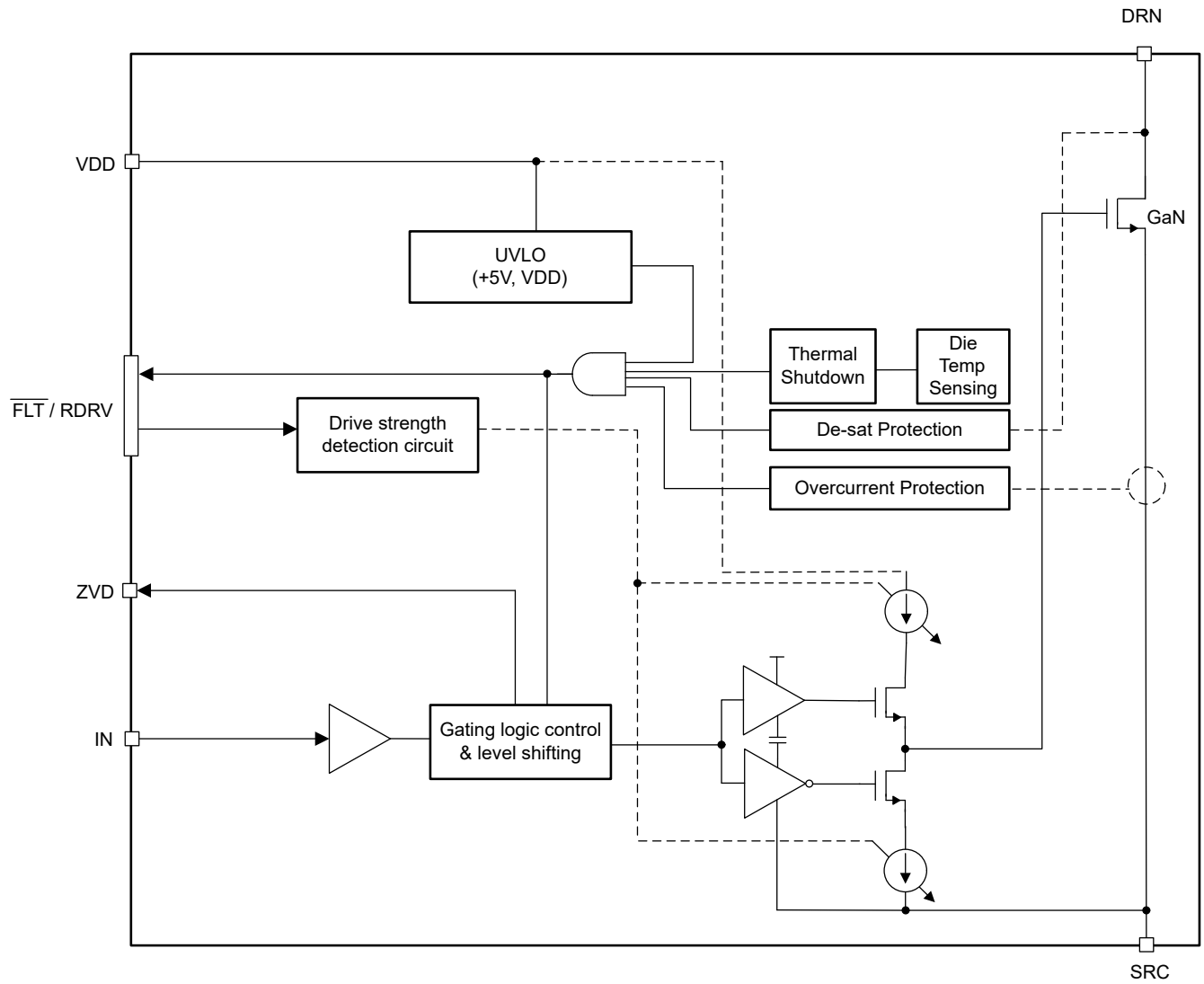

### 8.2.4 LMG3657R035 Functional Block Diagram

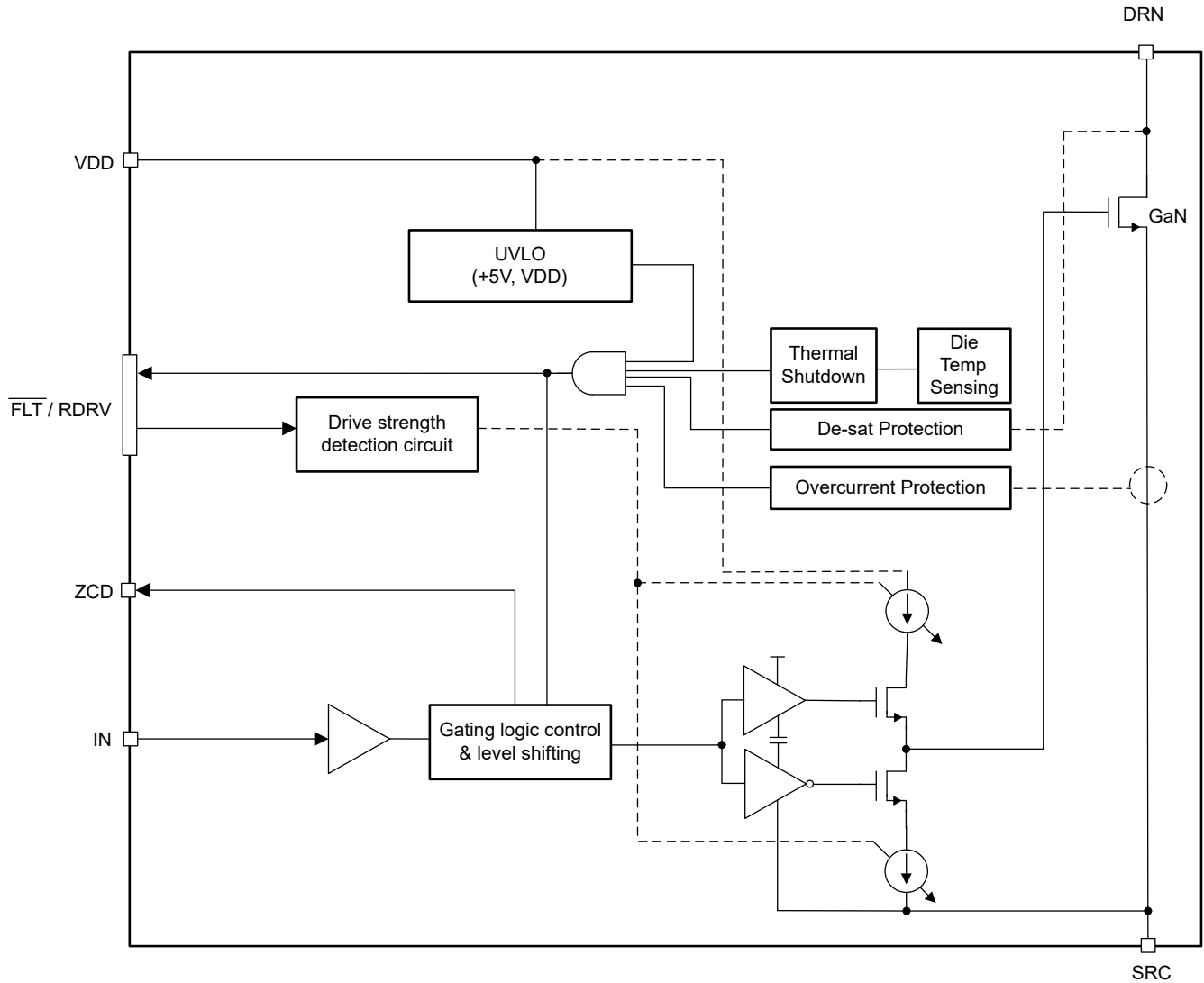

ADVANCE INFORMATION

## 8.3 Feature Description

### 8.3.1 Drive Strength Adjustment

The LMG365xR035 allows users to adjust the drive strength of the device and obtain a desired slew rate, which provides flexibility when optimizing switching losses and minimizing EMI. The typical value of turn-on slew rate and the maximum value of turn-off slew rate can be independently controlled by connecting the resistors and capacitor as shown in the [Figure 8-1](#). The resistance and capacitance on  $\overline{\text{FLT}}/\text{RDRV}$  pin is sensed once at power-up. To do so, the device forces a step-function from 0V to 1.2V on the external R1-R2-C2 network and measures the resulting current waveform. The DC measurement determines the turn-on slew rate setting, which is programmed by the resistance R1. The AC measurement dependent on R1-R2-C2 determines the turn-off slew rate setting, which is dependent on the magnitude of the drain-to-source current charging the output capacitance but can be limited to a maximum value programmed by the resistance R2 and capacitance C2, connected in parallel to R1. [Table 8-1](#) shows the recommended typical resistances and capacitance programming values at each slew rate setting.

The slew rate settings are determined one time at power up, then the  $\overline{\text{FLT}}/\text{RDRV}$  pin is used as a push-pull 5V digital output for fault monitoring, as described in [Fault Reporting](#). If R2 and C2 are not used, the device turns-off

at full-speed and the turn-off slew rate is strictly determined by the Coss and the load current. If R1 is not used, the device defaults to the 100V/ns slew rate setting. Using slower turn-on settings results in higher Eon losses, and slower turn-off settings results in higher Eoff losses.



図 8-1. Drive Strength Adjustment Circuit

表 8-1. Recommended Typical Programming Resistance (kΩ) and Capacitance (pF) for Adjusting Slew Rates

TYPICAL TURN-ON SLEW RATE (V/ns)	MAXIMUM TURN-OFF SLEW RATE (V/ns)								
		10		20		40		No limit <sup>(1)</sup>	
	R1	R2	C2	R2	C2	R2	C2	R2	C2
10	29.4	2	680	4.87	270	9.09	150	high impedance <sup>(2)</sup>	
20	35.7	2	680	4.75	270	8.66	150		
40	43.2	2	680	4.64	270	8.25	150		
60	53.6	2	680	4.64	270	8.06	150		
80	69.8	2	680	4.53	270	7.68	150		
100	> 400 <sup>(2)</sup>	2	680	4.22	270	6.98	180		

(1) Fully dependent on the magnitude of the drain-to-source current charging the output capacitance

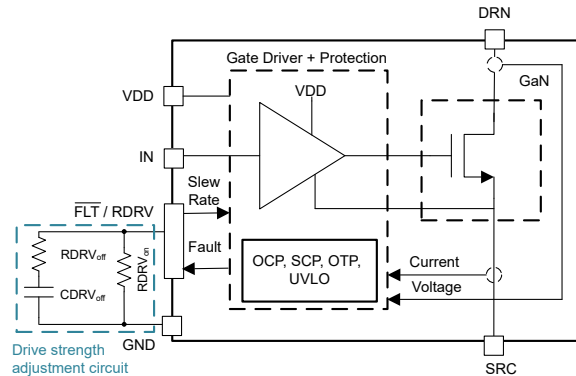
(2) Open-circuit connection for programming resistances is acceptable

For example, setting R1 = 53.6kΩ, R2 = 4.64kΩ and C2 = 270pF results in turn-on slew rate of 60V/ns and turn-off slew rate is limited to a maximum of 20V/ns.

### 8.3.2 VDD Supply

VDD is the input supply for the internal circuits. Wide voltage ranges from 9V to 26V are supported on VDD pin.

### 8.3.3 Overcurrent and Short-Circuit Protection

There are two types of current faults which can be detected by the driver: overcurrent fault and short-circuit fault.

The overcurrent protection (OCP) circuit monitors drain current and compares that current signal with an internally set limit  $I_{T(OC)}$ . Upon detection of the overcurrent, the LMG365xR035 performs cycle-by-cycle protection as shown in 図 8-2. In this mode, the GaN device is shut off when the drain current crosses the  $I_{T(OC)}$  plus a delay  $t_{off(OC)}$ , but the overcurrent signal clears after the IN pin signal goes low. In the next cycle, the GaN device can turn on as normal. The cycle-by-cycle function can be used in cases where steady-state operation current is below the OCP level but transient response can still reach current limit, while the circuit operation cannot be paused. The cycle-by-cycle function also prevents the GaN device from overheating by overcurrent induced conduction losses.

The short-circuit protection is based on desaturation (de-sat) detection, which monitors the drain-source voltage  $V_{DS}$  and compares the voltage with an internally set limit  $V_{T(Idsat)}$ . If the OC occurs before the de-sat, the  $V_{DS}$  is below the threshold, then OC is triggered, else de-sat is triggered as shown in 図 8-3. Saturation can be



damaging for the GaN to continue to operate in that condition. Therefore, if a de-sat is detected, the GaN device is turned off with an intentionally slowed driver so that a lower overshoot voltage and ringing can be achieved during the turn-off event. This fast response circuit helps protect the GaN device even under a hard short-circuit condition. In this protection, the GaN device is shut off and held off until the fault is reset by either holding the IN pin low for a period of time defined in the [Specifications](#) or removing power from VDD.

For safety considerations, OCP allows cycle-by-cycle operation while de-sat latches the device until reset. Both faults are reported on the FLT/RDRV pin.



図 8-2. Cycle-by-Cycle Overcurrent Protection Operation



図 8-3. Overcurrent Detection vs Desaturation Detection

### 8.3.4 Overtemperature Protection

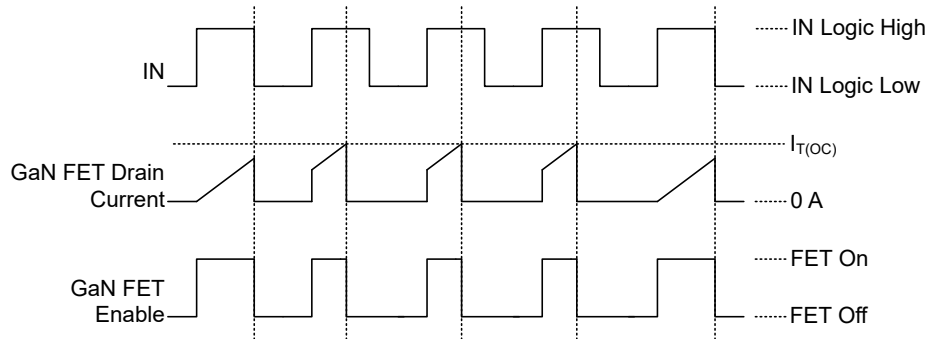
The overtemperature protection holds off the GaN power FET if the LMG365xR035 temperature is above the overtemperature protection threshold. The overtemperature protection hysteresis avoids erratic thermal cycling. An overtemperature fault is reported on the  $\overline{\text{FLT}}/\text{RDRV}$  pin when the overtemperature protection is asserted.  $\overline{\text{FLT}}/\text{RDRV}$  de-asserts and the device automatically returns to normal operation after the device temperature fall below the negative-going trip point.

### 8.3.5 UVLO Protection

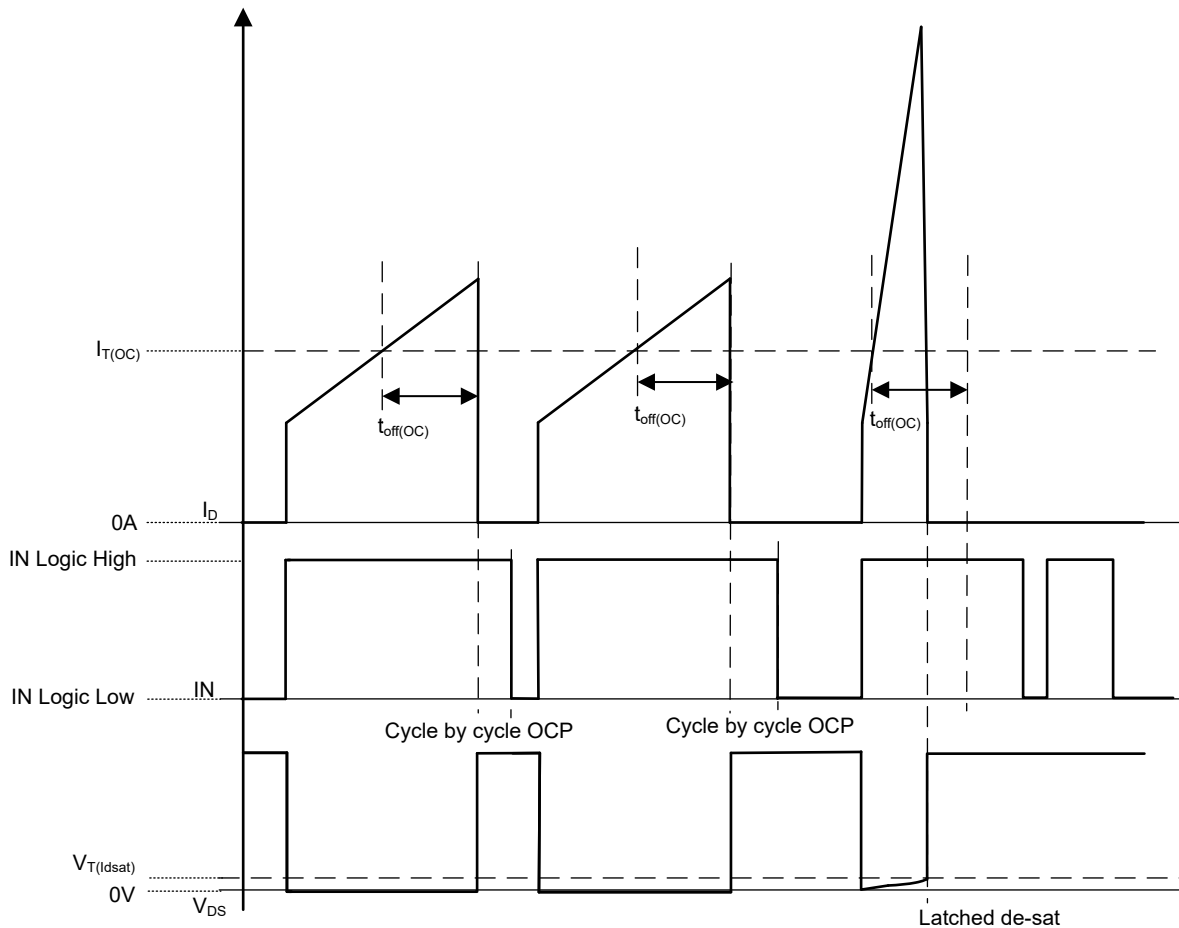
The LMG365xR035 supports a wide range of  $V_{\text{DD}}$  voltages. However, when the  $V_{\text{DD}}$  voltage is below  $V_{\text{DD}}$  UVLO threshold, the GaN device stops switching and is held off. The  $V_{\text{DD}}$  UVLO voltage hysteresis prevents on-off chatter near the UVLO voltage trip point. The  $\overline{\text{FLT}}/\text{RDRV}$  pin is pulled low as an indication of UVLO.

### 8.3.6 Fault Reporting

All faults are reported on the  $\overline{\text{FLT}}/\text{RDRV}$  pin, which serves as both an input and output pin.

The  $\overline{\text{FLT}}/\text{RDRV}$  is configured as an input only at the time of powerup to adjust the drive-strength, as described in [Drive Strength Adjustment](#).

The  $\overline{\text{FLT}}/\text{RDRV}$  then used as an active low digital output, indicating the fault status thereafter. The pin is a push-pull 5V digital output which goes high when all faults have cleared, which means that there is additional quiescent current through R1 when the pin is forced high.

Depending on the input threshold levels for the external digital receiver connected to the fault pin, the 1.2V which is forced on this pin at power-up could be interpolated as either high or low. For this reason, it is recommended that the receiver has higher thresholds such as those common for CMOS-compatible inputs and not use TTL compatible inputs. If the input thresholds are lower, the 1.2V at power-up can be interpreted as a "high" and therefore showing that the device is not faulted when still powering up.

### 8.3.7 Auxiliary LDO (LMG3651R035 Only)

There is a 5V voltage regulator inside the part used to supply external loads, such as digital isolators for the high-side drive signal. The digital outputs of the part use this rail as their supply. No capacitor is required for stability, but transient response is poor if no external capacitor is provided. If the application uses this rail to supply external circuits, TI recommends to have a capacitor of at least 0.1 $\mu\text{F}$  for improved transient response. A larger capacitor can be used for further transient response improvement. The decoupling capacitor used here must be a low-ESR ceramic type. Capacitances above 0.47 $\mu\text{F}$  will slow down the start-up time of the LMG365xR035 due to the ramp-up time of the 5V rail.

### 8.3.8 Zero-Voltage Detection (ZVD) (LMG3656R035 Only)

The zero-voltage switching (ZVS) converters are widely used to improve the power converter's efficiency. However, in those soft-switching topologies like LLC and triangular current mode (TCM) totem pole PFC, the device can lose ZVS depending on the load condition, inductor, magnetic parameters and control techniques, which affects the system efficiency. To insure ZVS, certain design margins or additional circuits are needed which sacrifices the converter performance and adds components.

To simplify the system design for soft-switching converters, LMG3656R035 part integrates a zero-voltage detection (ZVD) circuit that provides a digital feedback signal to indicate if the device has achieved ZVS in the current switching cycle. The circuit diagram is shown in 8-4. When the IN pin signal goes high, the logic circuit checks if the device  $V_{DS}$  has reached below 0V to determine whether the device has achieved zero voltage switching in this switching cycle. Once a ZVS is identified, a pulse-output with a width of  $T_{WD\_ZVD}$  will be sent out from the ZVD pin after a delay time of  $T_{DL\_ZVD}$  as indicated in 7-3. Note a certain third quadrant conduction time is required to allow the device detecting a zero-voltage switching, and  $T_{3rd\_ZVD}$  is a function of the gate driver strength.

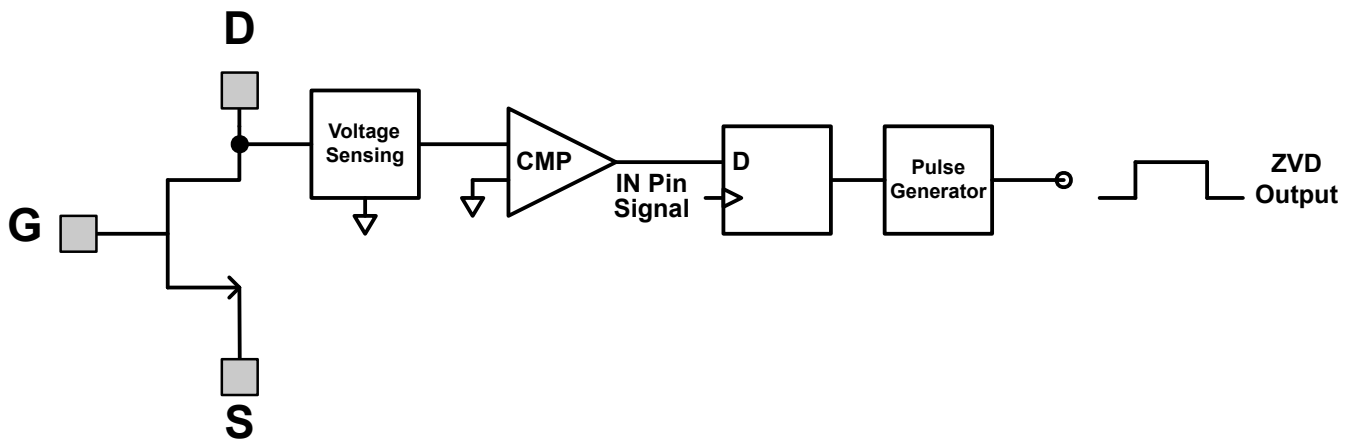

8-4. Circuit Diagram for Zero-Voltage Detection Circuit Block Diagram

The timings of the ZVD output corresponding to a continuous conduction mode Buck converter is shown in 8-5, and the purpose is to demonstrate how ZVD function works in both hard-switching and soft-switching conditions. The load current going out of the switch node is defined as positive. In CCM buck operation, the high-side the hard-switching device while the low-side device can achieve zero-voltage switching with a proper dead-time settings. In the first switching cycle when low-side GaN IN pin rises, the switch-node voltage  $V_{DS}$  has dropped below zero and stays in third quadrant conduction for a period of  $T_1$ . Since this third quadrant conduction time  $T_1$  is larger than the detection time  $T_{3rd\_ZVD}$  specified in electrical characteristic table, a zero-voltage switching is identified and the ZVD pin outputs a pulse signal to indicate that, and the pulse width of the ZVD pulse is also defined in the electrical characteristic table as  $T_{WD}$ . In the second switching cycle, the device is turned on earlier, and the third quadrant conduction time  $T_2$  is less than  $T_{3rd\_ZVD}$ . In this case, the ZVD signal stays low though the device has achieved ZVS. In the third switching cycle, the IN pin signal is advanced even earlier, and the device is in partial hard-switching. Accordingly, the ZVD output stays low in this case. Note the high side ZVD output stays low in this CCM buck operation as it always has hard-switching.



図 8-5. ZVD Function in a CCM Buck Converter

The ZVD function can facilitate the control in soft-switching topology, to illustrate it, the ZVD waveforms in a TCM totem pole PFC is shown in 図 8-6. In this diagram, the positive cycle is considered with  $V_{IN} > 0.5 V_{OUT}$ , and the load current going into the switch node is defined as positive. In the first switching cycle, the load current builds enough negative current, and the low-side device achieves ZVS with a clear third quadrant conduction time beyond  $T_{3rd\_DET}$ . Therefore, the ZVD outputs a pulse signal and provide the ZVS information back. The ZVD pulses are missing in the next two switching cycles because the third quadrant conduction time becomes shorter in second cycle and the device actual loses ZVS in the third cycle.

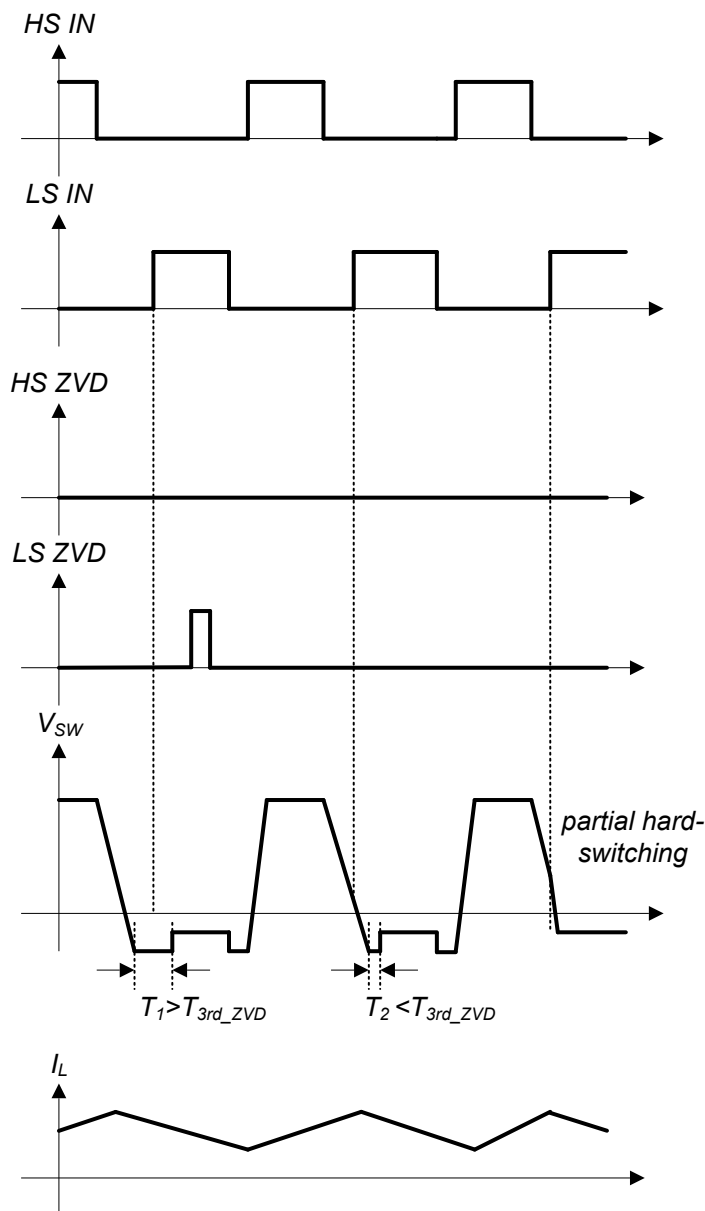

図 8-6. ZVD Function in a TCM TP PFC Converter

### 8.3.9 Zero-Current Detection (ZCD) (LMG3657R035 Only)

GaN FET is usually used for high frequency soft-switching and the detection of FET current zero-crossing is needed for system control. LMG3657R035 integrates a zero current detection (ZCD) circuit that provides a digital feedback signal to indicate the when the drain-to-source current is positive. When the IN pin signal goes high, the ZCD circuit includes a blanking time  $t_{ZCD\_Blank}$ , to prevent nuisance ZCD triggering during the turn-on transient. Following the blanking period, the ZCD circuit monitors the drain-to-source current. If the current is negative, a pulse-output with a width of  $t_{WD\_ZVD}$  is set on the ZCD pin after detecting the zero-crossing point, with a delay time of  $t_{ZC\_Det}$ . If the current is positive, the pulse output is set on the ZCD pin immediately, as indicated in the timing diagrams below.

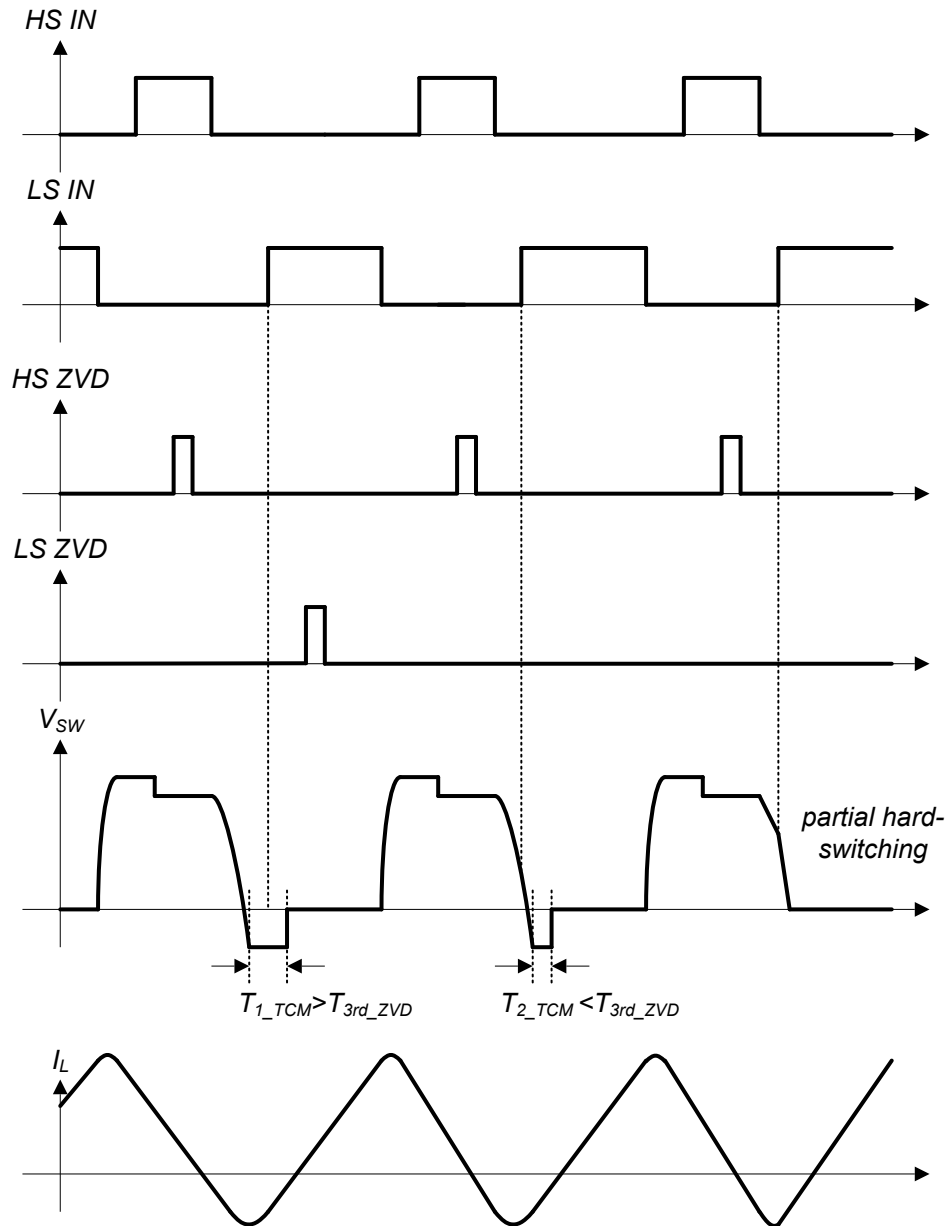
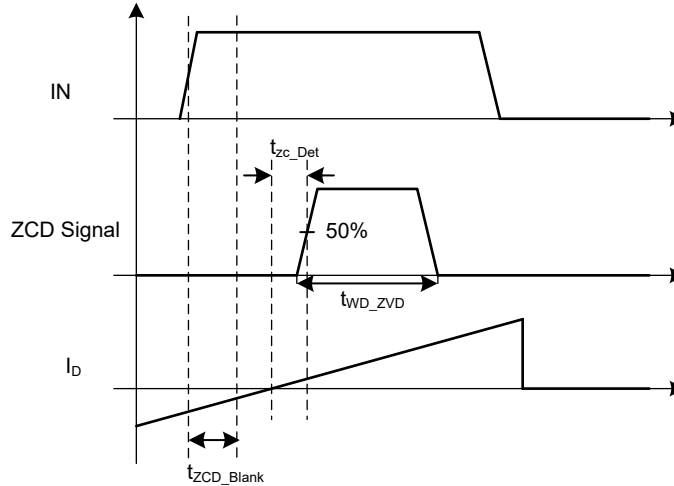

8-7. ZCD Timing Diagram When FET Turns ON Into Negative Current

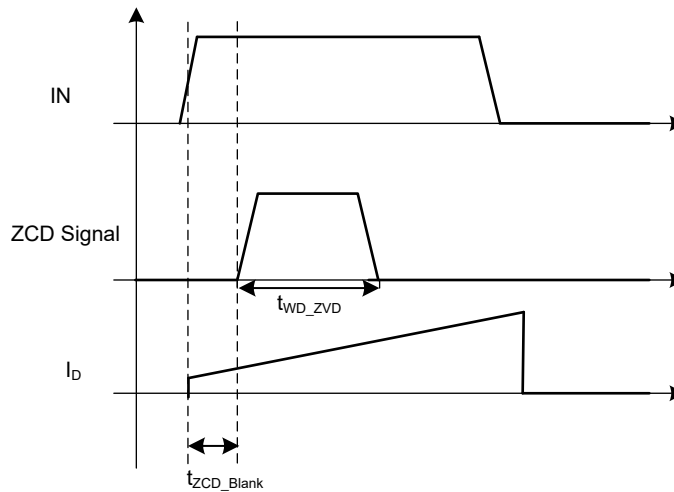

8-8. ZCD Timing Diagram When FET Turns ON Into Positive Current

### 8.4 Device Functional Modes

The device has one mode of operation that applies when operated within the Recommended Operating Conditions.

## 9 Application and Implementation

### 注

Information in the following applications sections is not part of the TI component specification, and TI does not warrant its accuracy or completeness. TI's customers are responsible for determining suitability of components for their purposes, as well as validating and testing their design implementation to confirm system functionality.

### 9.1 Application Information

The LMG365xR035 is a power IC targeting hard-switching and soft-switching applications operating up to 480V bus voltages. GaN devices offer zero reverse-recovery charge enabling high-frequency, hard-switching in applications like the totem-pole PFC. Low  $Q_{oss}$  of GaN devices also benefits soft-switching converters, such as the LLC and phase-shifted full-bridge configurations. As half-bridge configurations are the foundation of the two mentioned applications and many others, this section describes how to use the LMG365xR035 in a half-bridge configuration.

(1)

## 9.2 Typical Application



図 9-1. LMG3650R035 Typical Half-Bridge Application With Isolated Power Supply



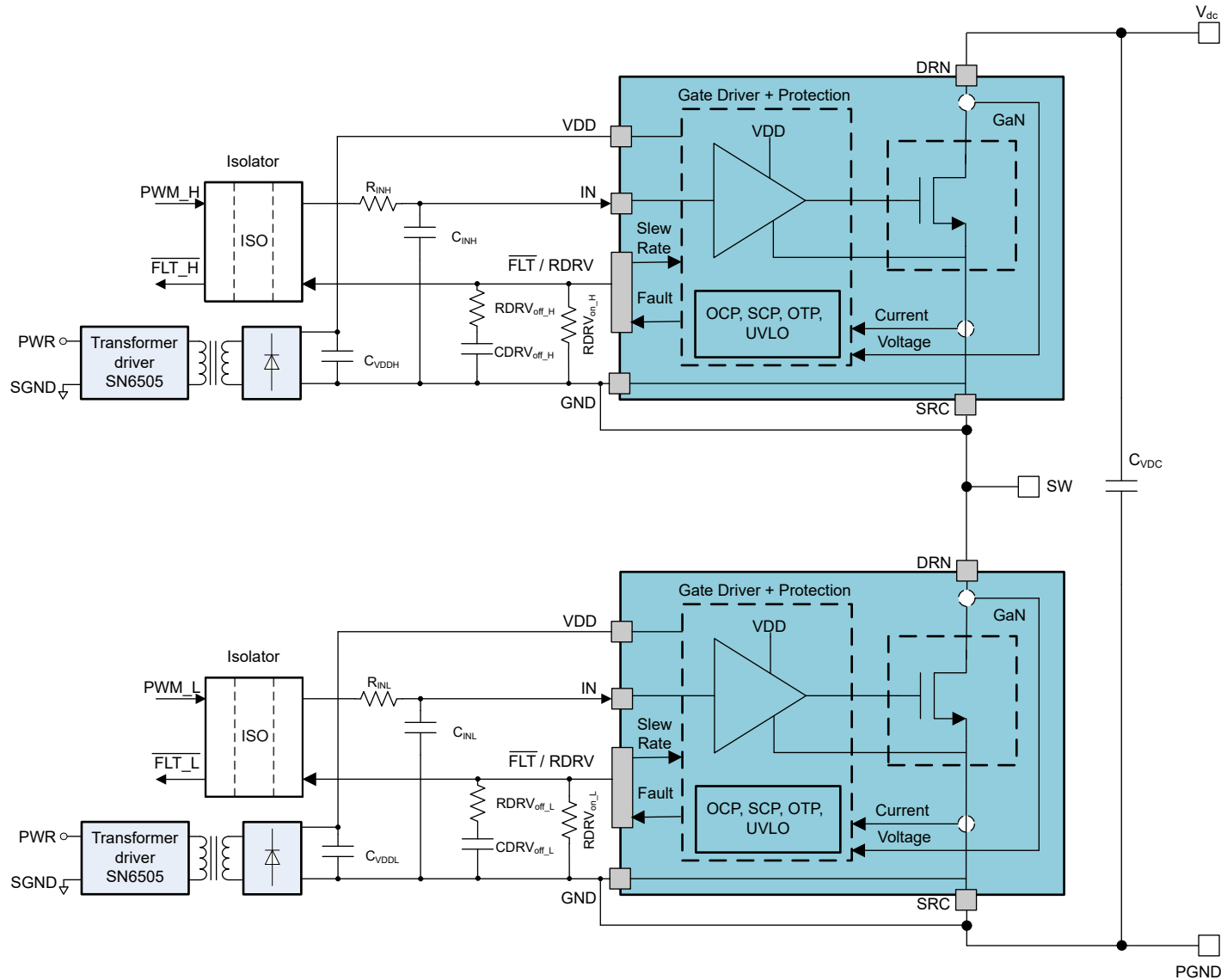

図 9-2. LMG3651R035 Typical Half-Bridge Application With Isolated Power Supply

ADVANCE INFORMATION



図 9-3. LMG3656R035 or LMG3657R035 Typical Half-Bridge Application With Isolated Power Supply

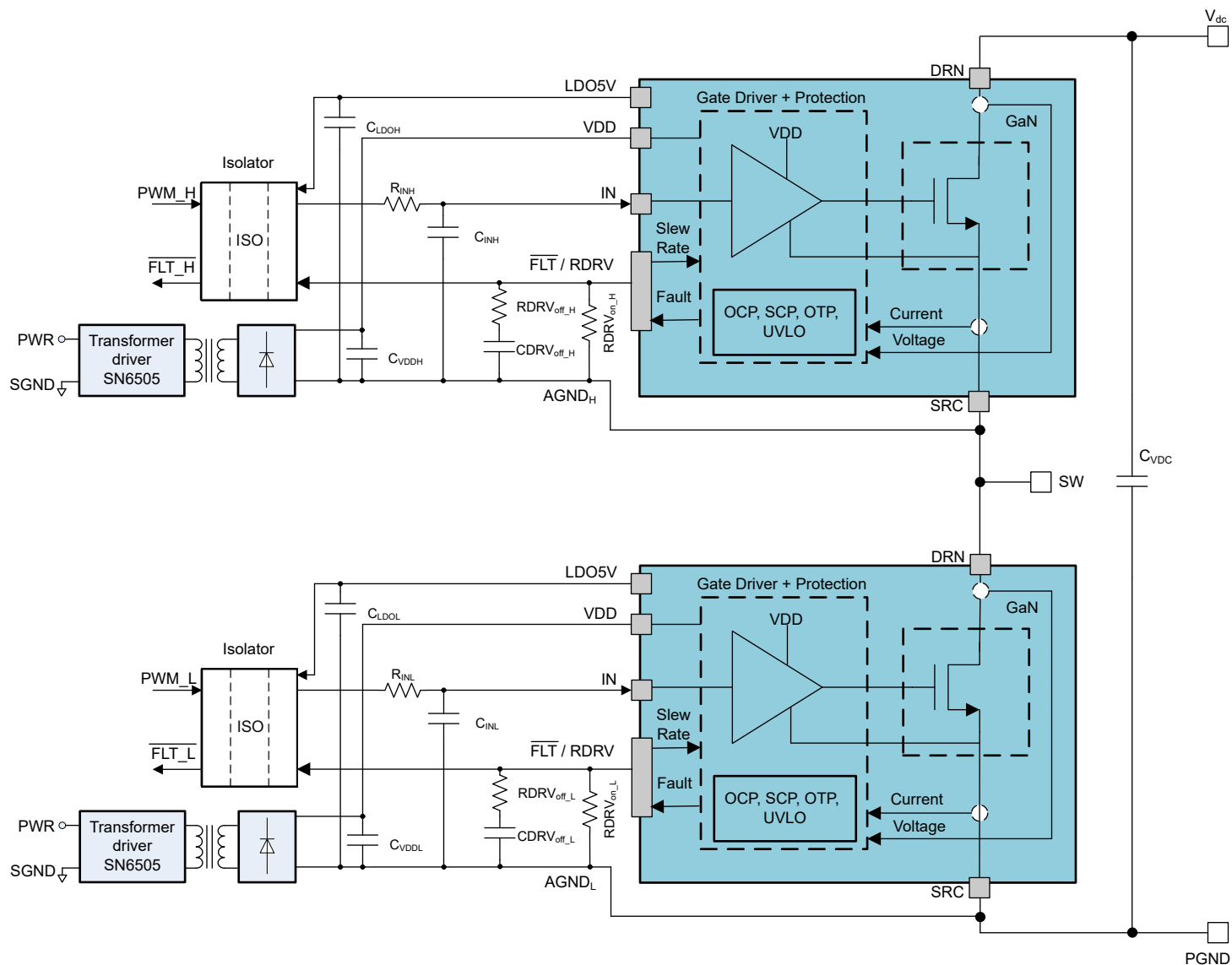

図 9-4. LMG3650R035 Typical Half-Bridge Application With Bootstrap

ADVANCE INFORMATION

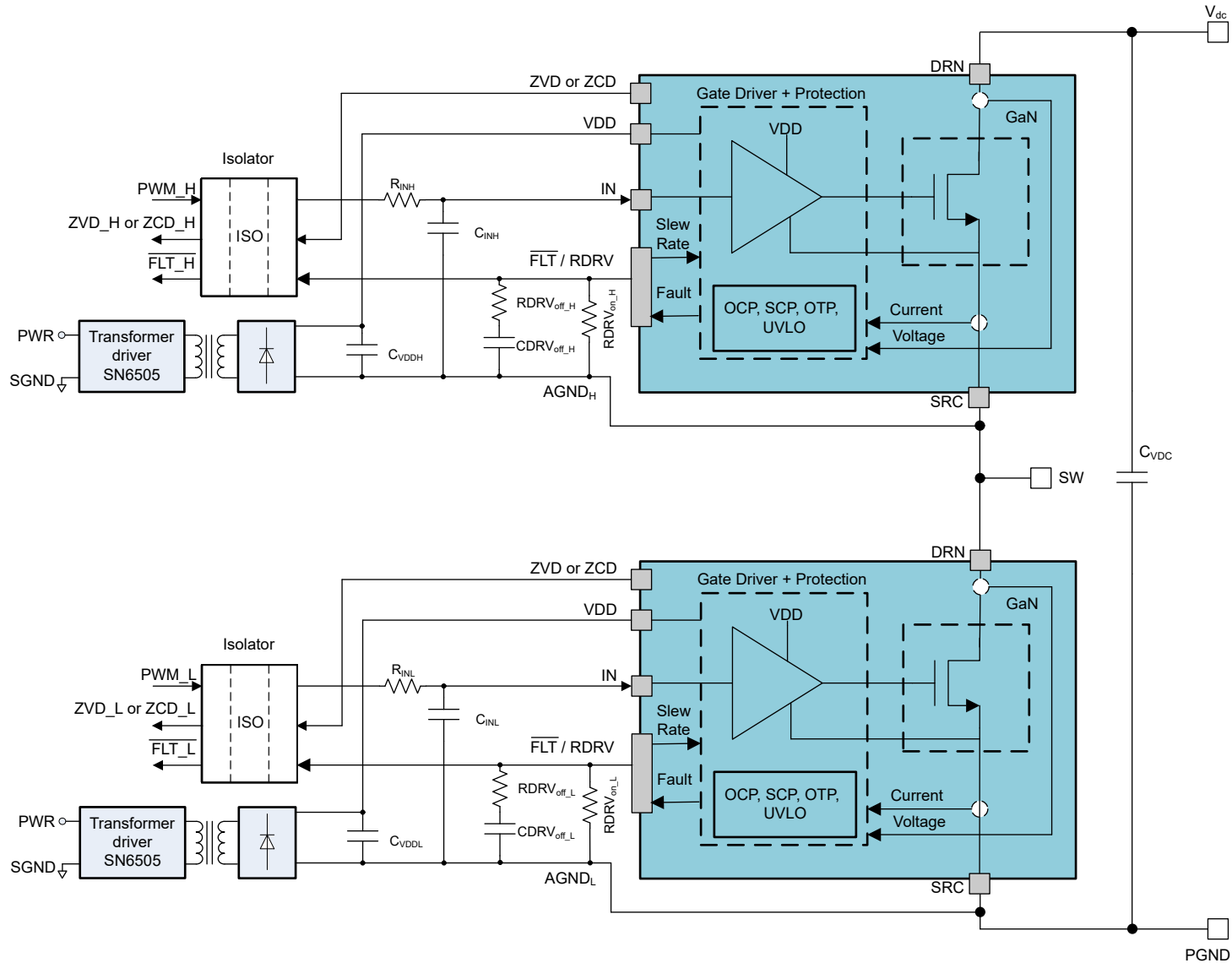

図 9-5. LMG3651R035 Typical Half-Bridge Application With Bootstrap

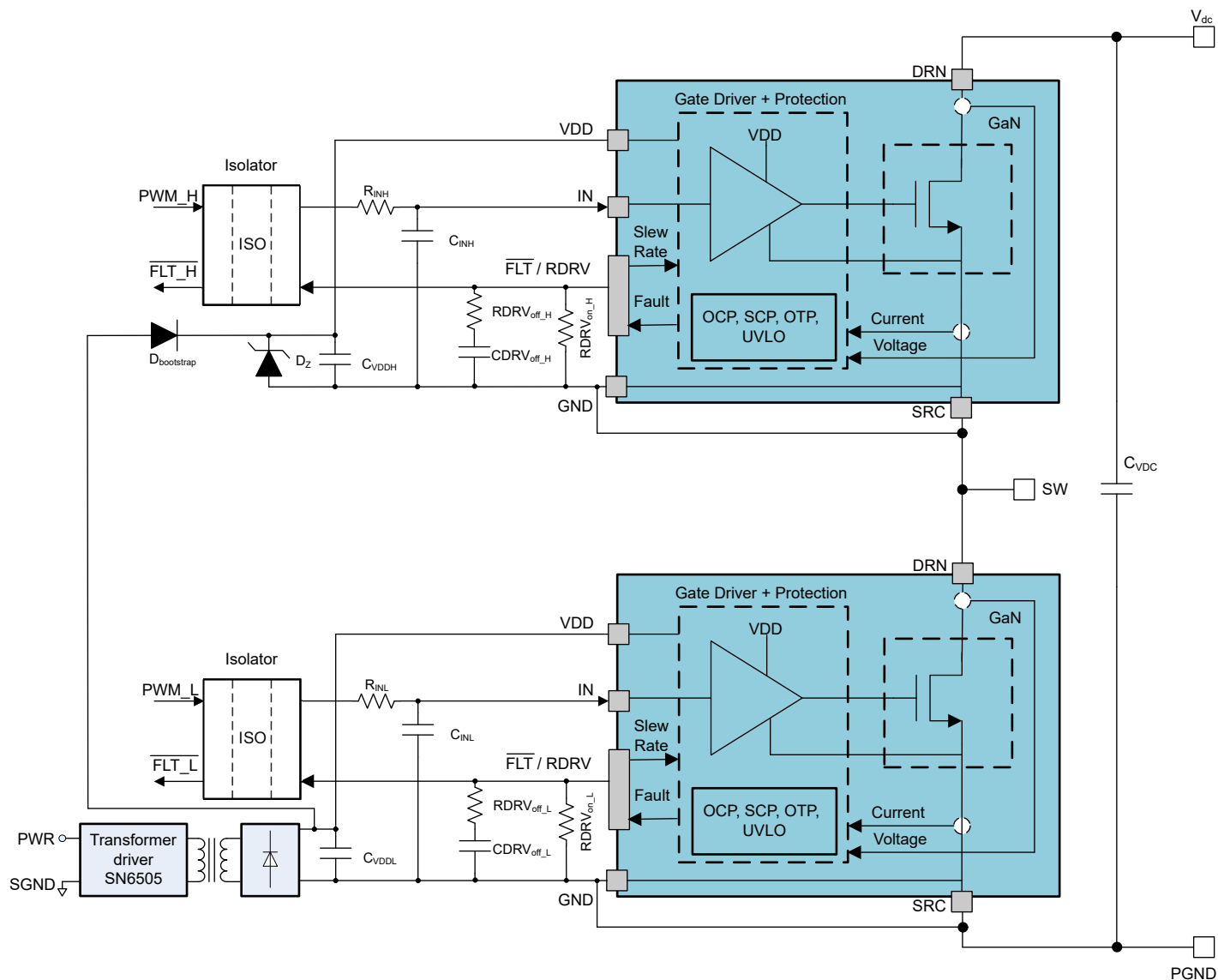
ADVANCE INFORMATION

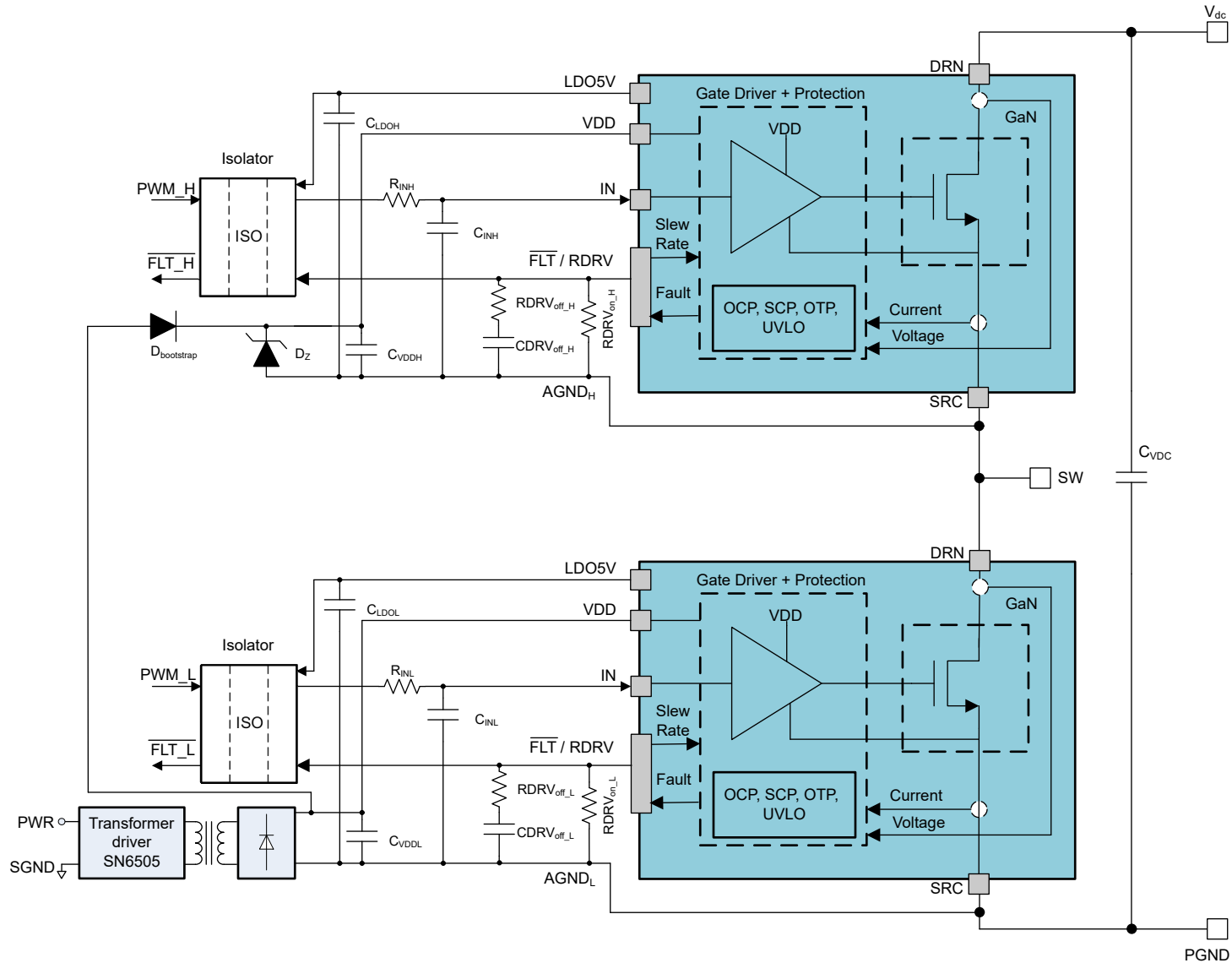

図 9-6. LMG3656R035 or LMG3657R035 Typical Half-Bridge Application With Bootstrap

ADVANCE INFORMATION

### 9.2.1 Design Requirements

This design example is for a hard-switched boost converter which is representative of PFC applications. [Design Parameters](#) shows the system parameters for this design.

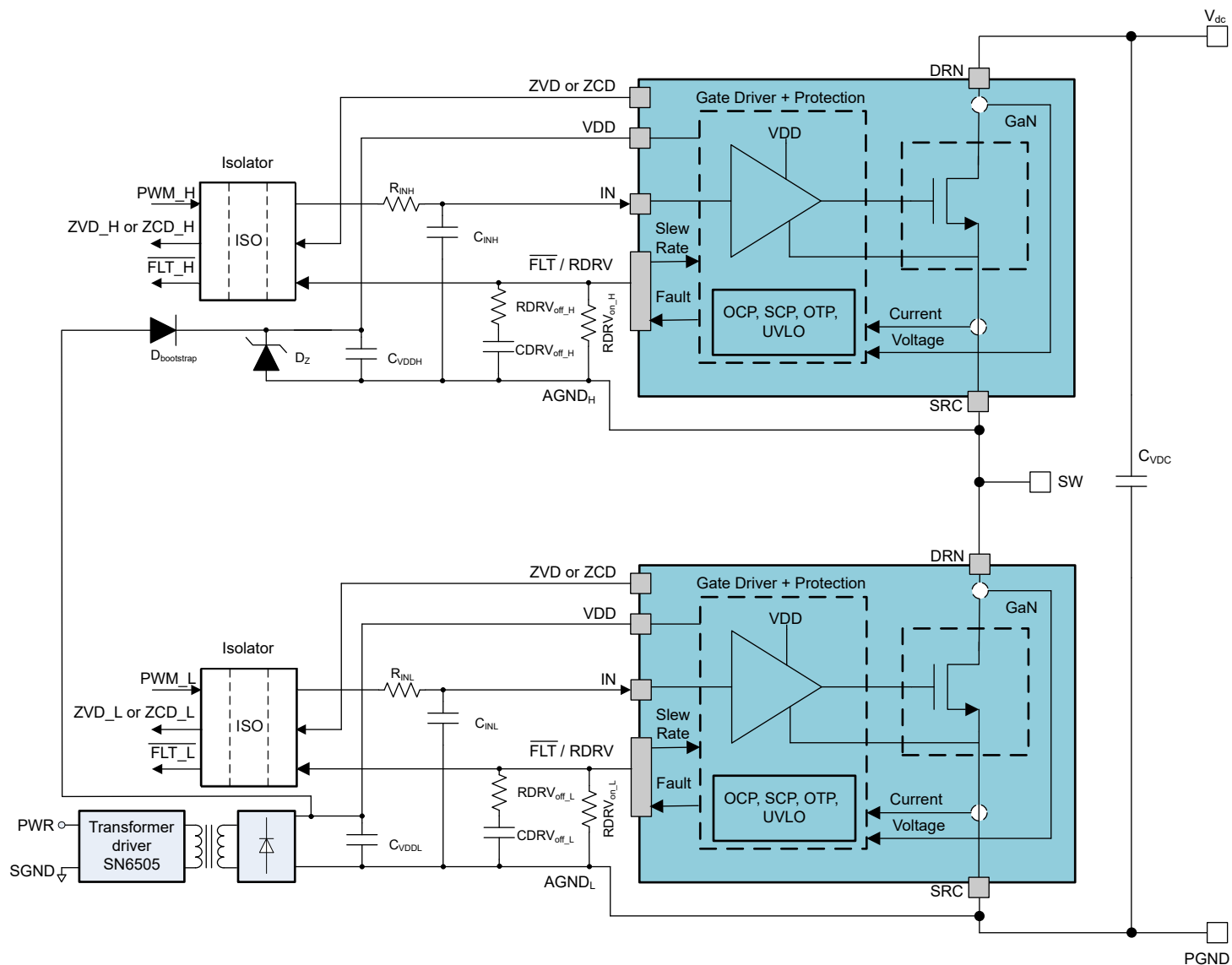
**表 9-1. Design Parameters**

PARAMETER	VALUE
Input voltage	200VDC
Output voltage	400VDC
Input (inductor) current	20A
Switching frequency	100kHz

### 9.2.2 Detailed Design Procedure

In high-voltage power converters, circuit design and PCB layout are essential for high-performance power converters. As designing a power converter is out of the scope of this document, this data sheet describes how to build well-behaved half-bridge configurations with the LMG365xR035.

#### 9.2.2.1 Slew Rate Selection

The slew rate of LMG365xR035 can be adjusted between approximately 10 V/ns and 100V/ns by connecting drive strength adjustment circuit. Refer to [Drive Strength Adjustment](#) for the details.

The slew rate affects GaN device performance in terms of:

- Switching loss
- Voltage overshoot
- Noise coupling
- EMI emission

Generally, high slew rates provide low switching loss, but high slew rates can also create higher voltage overshoot, noise coupling, and EMI emissions. Following the design recommendations in this data sheet helps mitigate the challenges caused by a high slew rate. The LMG365xR035 offers circuit designers the flexibility to select the proper slew rate for the best performance of their applications.

#### 9.2.2.2 Signal Level-Shifting

In half-bridges, high-voltage level shifters or digital isolators must be used to provide isolation for signal paths between the high-side device and control circuit. Using an isolator is optional for the low-side device. However, using an isolator equalizes the propagation delays between the high-side and low-side signal paths, and provides the ability to use different grounds for the GaN device and the controller. If an isolator is not used on the low-side device, the control ground and the power ground must be connected at the device and nowhere else on the board. For more information, see [Layout Guidelines](#). With fast-switching devices, common ground inductance can easily cause noise issues without the use of an isolator.

Choosing a digital isolator for level-shifting is important for improvement of noise immunity. As GaN device can easily create high  $dv/dt$ ,  $> 50V/ns$ , in hard-switching applications, TI highly recommends to use isolators with high common-mode transient immunity (CMTI) and low barrier capacitance. Isolators with low CMTI can easily generate false signals, which could cause shoot-through. The barrier capacitance is part of the isolation capacitance between the signal ground and power ground, which is in direct proportion to the common mode current and EMI emission generated during the switching. Additionally, TI strongly encourages to select isolators which are not edge-triggered. In an edge-triggered isolator, a high  $dv/dt$  event can cause the isolator to flip states and cause circuit malfunction.

Generally, ON/OFF keyed isolators with default output low are preferred. Default low state ensures the system will not shoot-through when starting up or recovering from fault events. As a high CMTI event would only cause a very short (a few nanoseconds) false pulse, TI recommends a low pass filter, like 300Ω and 22pF R-C filter, to be placed at the driver input to filter out these false pulses.

## 9.3 Power Supply Recommendations

The LMG365xR035 only requires an unregulated VDD power supply from 9V to 26V. The low-side supply can be obtained from the local controller supply. The supply of the high-side device must come from an isolated supply or a bootstrap supply.

### 9.3.1 Using an Isolated Power Supply

Using an isolated power supply to power the high-side device has the advantage that it works regardless of continued power-stage switching or duty cycle. Using an isolated power supply can also power the high-side device before power-stage switching begins for a smooth start-up.

The isolated supply can be obtained with a push-pull converter, a flyback converter, a FlyBuck™ converter, or an isolated power module. When using an unregulated supply, the input of LMG365xR035 must not exceed the maximum supply voltage. A 24V TVS diode can be used to clamp the VDD voltage of LMG365xR035 for additional protection. Minimizing the inter-winding capacitance of the isolated power supply or transformer is necessary to reduce switching loss in hard-switched applications. Furthermore, capacitance across the isolated bias supply inject high currents into the signal-ground of the LMG365xR035 and can cause problematic ground-bounce transients. A common-mode choke can alleviate most of these issues.

### 9.3.2 Using a Bootstrap Diode

In half-bridge configuration, a floating supply is necessary for the high-side device. To obtain the best performance of LMG365xR035, TI highly recommends [Using an Isolated Power Supply](#). A bootstrap supply can be used with the recommendations of this section.

#### 9.3.2.1 Diode Selection

The LMG365xR035 offers no reverse-recovery charge and very limited output charge. Hard-switching circuits using the LMG365xR035 also exhibit high voltage slew rates. A compatible bootstrap diode must not introduce high output charge and reverse-recovery charge.

A silicon carbide diode, like the GB01SLT06-214, can be used to avoid reverse-recovery effects. The SiC diode has an output charge of 3nC. Although there is additional loss from its output charge, it does not dominate the losses of the switching stage.

#### 9.3.2.2 Managing the Bootstrap Voltage

In a synchronous buck or other converter where the low-side switch occasionally operates in third-quadrant, the bootstrap supply charges through a path that includes the third-quadrant voltage drop of the low-side LMG365xR035 during the dead time as shown in [Charging Path for Bootstrap Diode](#). This third-quadrant drop can be large, which can over-charge the bootstrap supply in certain conditions. The V<sub>DD</sub> supply of LMG365xR035 must be kept below 18V.

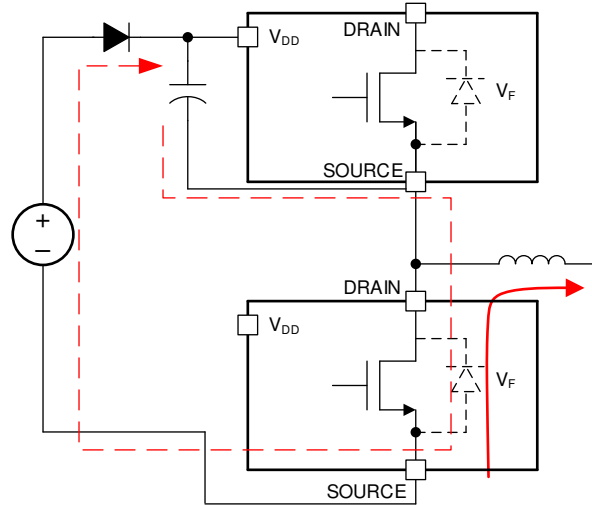

**9-7. Charging Path for Bootstrap Diode**

As shown in [Suggested Bootstrap Regulation Circuit](#), the recommended bootstrap supply includes a bootstrap diode, a series resistor, and a 16V TVS or Zener diode in parallel with the  $V_{DD}$  bypass capacitor to prevent damaging the high-side LMG365xR035. The series resistor limits the charging current at start-up and when the low-side device is operating in third-quadrant mode. This resistor must be selected to allow sufficient current to power the LMG365xR035 at the desired operating frequency. At 100kHz operation, TI recommends a value of approximately  $2\Omega$ . At higher frequencies, this resistor value must be reduced or the resistor omitted entirely to ensure sufficient supply current.

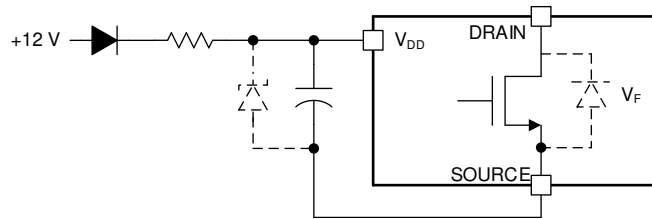

**9-8. Suggested Bootstrap Regulation Circuit**

## 9.4 Layout

### 9.4.1 Layout Guidelines

The layout of the LMG365xR035 is critical to its performance and functionality. Because the half-bridge configuration is typically used with these GaN devices, layout recommendations are considered with this configuration. A four-layer or higher layer count board is required to reduce the parasitic inductances of the layout to achieve suitable performance. Critical layout guidelines are summarized below, and more details are further elaborated in the following sections.



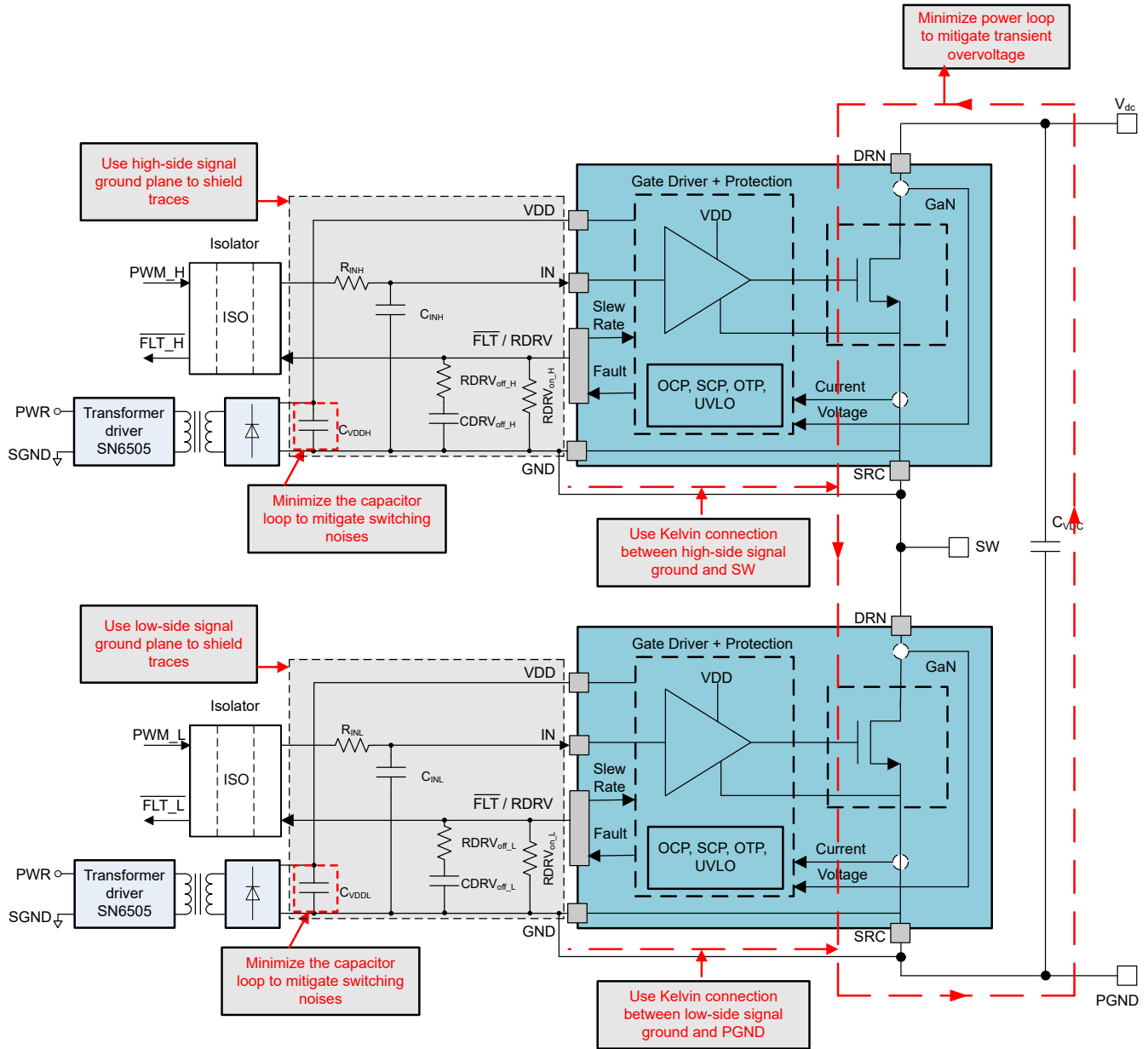

ADVANCE INFORMATION

図 9-9. LMG3650R035 Typical Schematic With Layout Considerations

ADVANCE INFORMATION



图 9-10. LMG3651R035 Typical Schematic With Layout Considerations



ADVANCE INFORMATION

图 9-11. LMG3656R035 or LMG3657R035 Typical Schematic With Layout Considerations

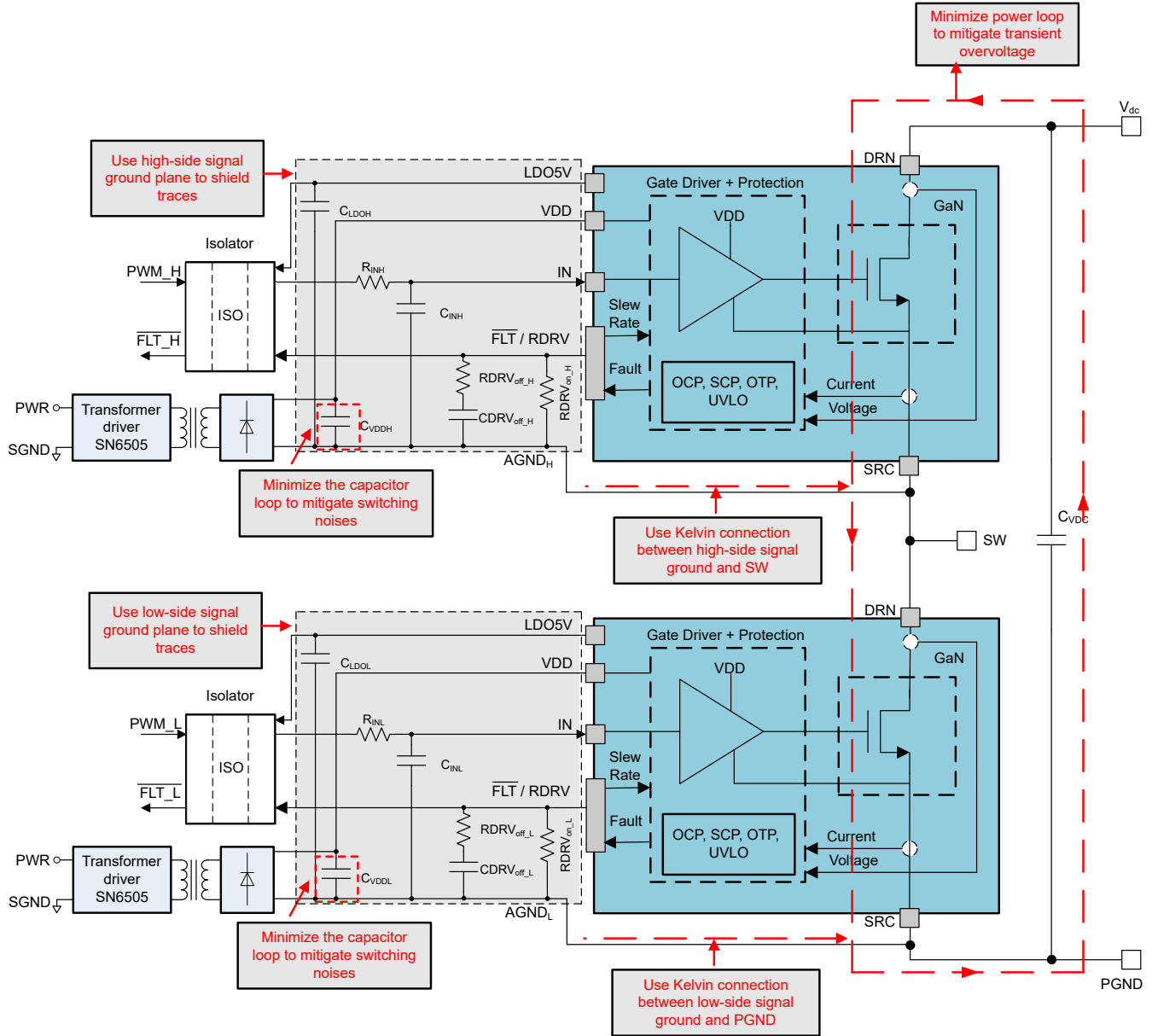
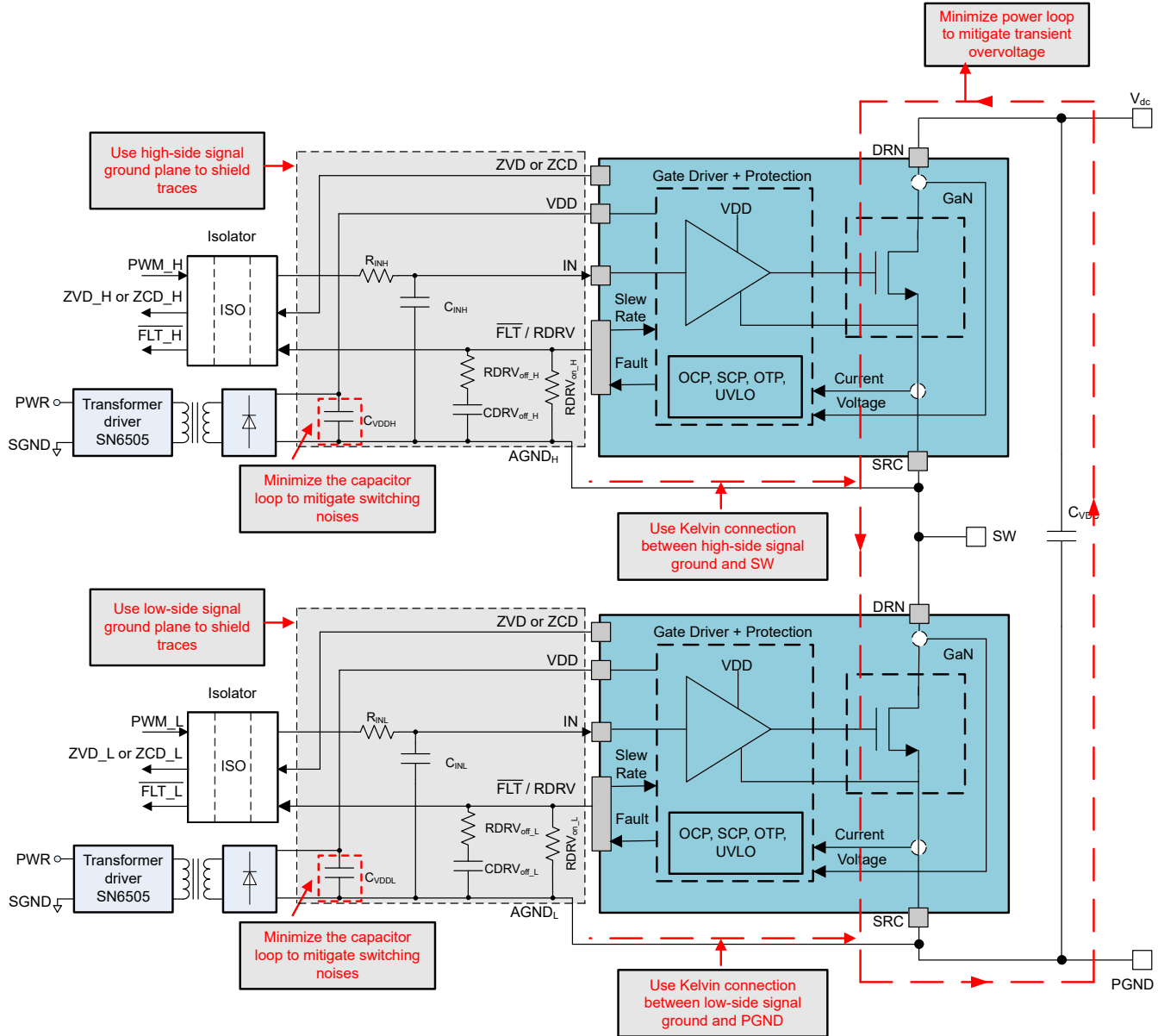
## 10 Device and Documentation Support

TI offers an extensive line of development tools. Tools and software to evaluate the performance of the device, generate code, and develop solutions are listed below.

### 10.1 ドキュメントの更新通知を受け取る方法

ドキュメントの更新についての通知を受け取るには、[www.tij.co.jp](http://www.tij.co.jp) のデバイス製品フォルダを開いてください。[通知] をクリックして登録すると、変更されたすべての製品情報に関するダイジェストを毎週受け取ることができます。変更の詳細については、改訂されたドキュメントに含まれている改訂履歴をご覧ください。

### 10.2 サポート・リソース

テキサス・インスツルメンツ E2E™ サポート・フォーラムは、エンジニアが検証済みの回答と設計に関するヒントをエキスパートから迅速かつ直接得ることができる場所です。既存の回答を検索したり、独自の質問をしたりすることで、設計に必要な支援を迅速に得ることができます。

リンクされているコンテンツは、各寄稿者により「現状のまま」提供されるものです。これらはテキサス・インスツルメンツの仕様を構成するものではなく、必ずしもテキサス・インスツルメンツの見解を反映したものではありません。テキサス・インスツルメンツの[使用条件](#)を参照してください。

### 10.3 Trademarks

FlyBuck™ and テキサス・インスツルメンツ E2E™ are trademarks of Texas Instruments.

すべての商標は、それぞれの所有者に帰属します。

### 10.4 静電気放電に関する注意事項



この IC は、ESD によって破損する可能性があります。テキサス・インスツルメンツは、IC を取り扱う際には常に適切な注意を払うことを推奨します。正しい取り扱いおよび設置手順に従わない場合、デバイスを破損するおそれがあります。

ESD による破損は、わずかな性能低下からデバイスの完全な故障まで多岐にわたります。精密な IC の場合、パラメータがわずかに変化するだけで公表されている仕様から外れる可能性があるため、破損が発生しやすくなっています。

### 10.5 用語集

[テキサス・インスツルメンツ用語集](#) この用語集には、用語や略語の一覧および定義が記載されています。

## 11 Revision History

資料番号末尾の英字は改訂を表しています。その改訂履歴は英語版に準じています。

DATE	REVISION	NOTES
December 2024	*	Initial Release

## 12 Mechanical, Packaging, and Orderable Information

The following pages include mechanical, packaging, and orderable information. This information is the most current data available for the designated devices. This data is subject to change without notice and revision of this document. For browser-based versions of this data sheet, refer to the left-hand navigation.

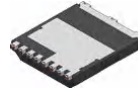

**KLA0009A**

**PACKAGE OUTLINE**

**TOLL - 2.35 mm max height**

TO LEADLESS

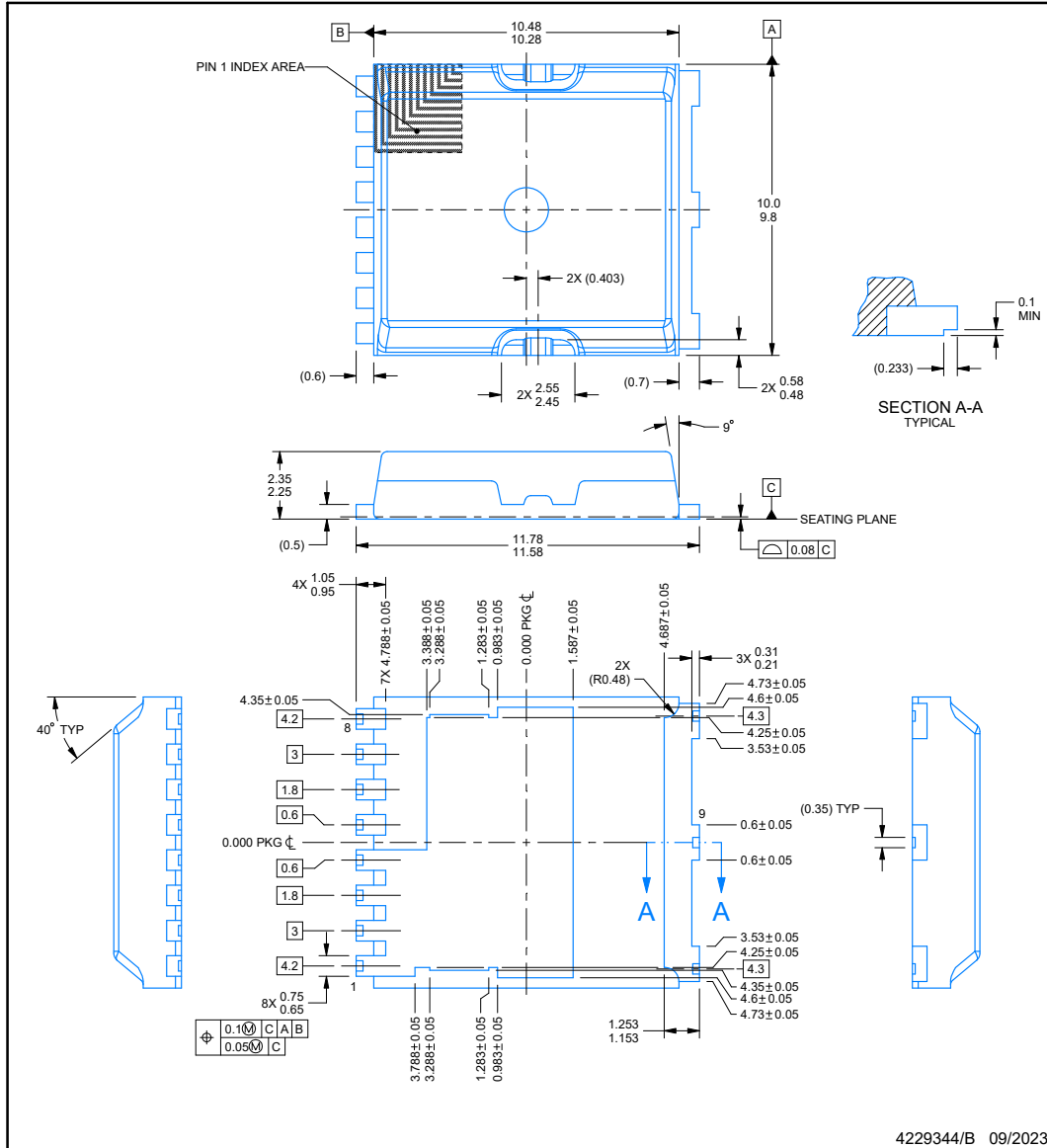

**NOTES:**

1. All linear dimensions are in millimeters. Any dimensions in parenthesis are for reference only. Dimensioning and tolerancing per ASME Y14.5M.
2. This drawing is subject to change without notice.
3. The package thermal pad must be soldered to the printed circuit board for thermal and mechanical performance.

**EXAMPLE BOARD LAYOUT**

**KLA0009A**

**TOLL - 2.35 mm max height**

TO LEADLESS

ADVANCE INFORMATION

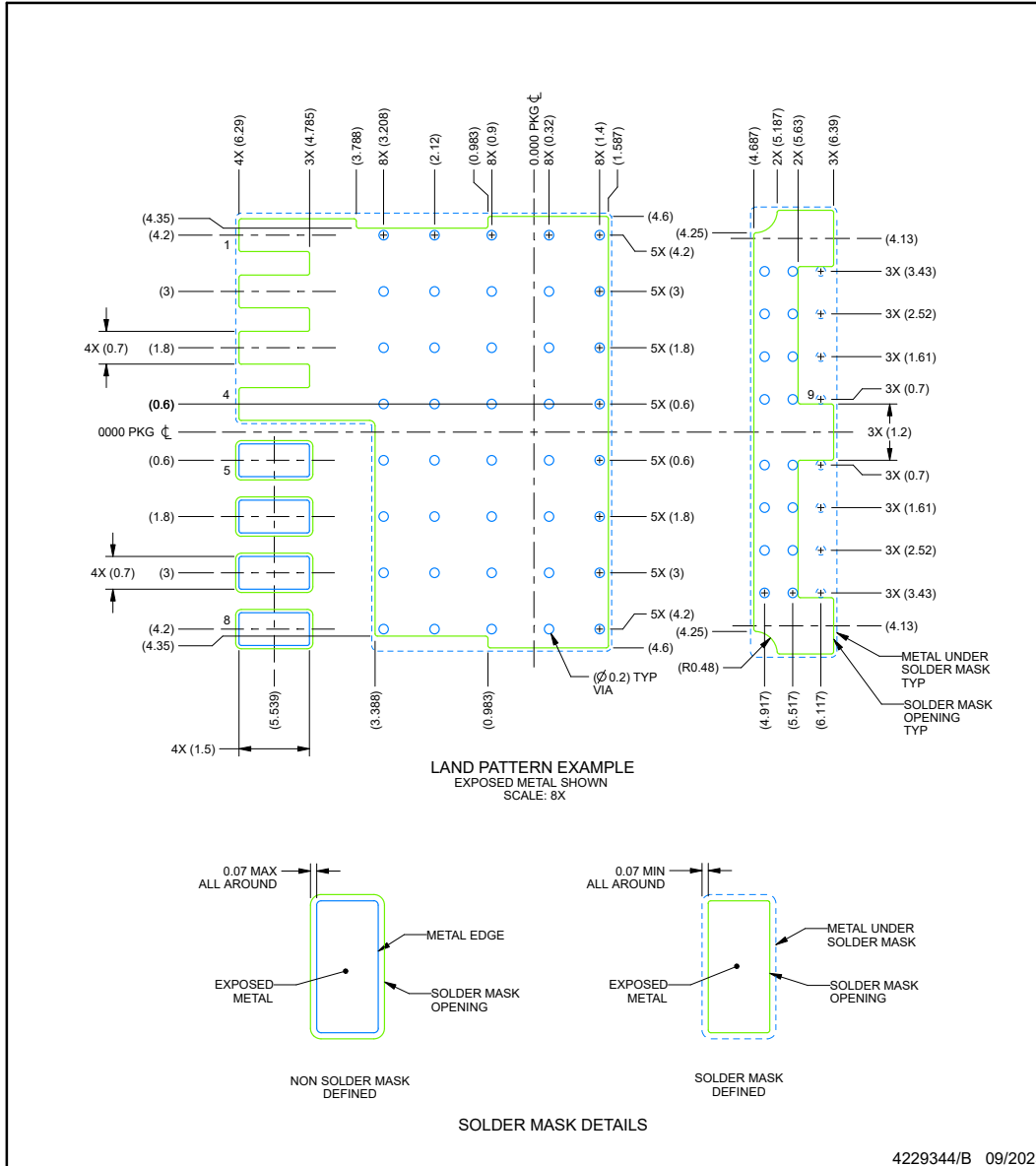

NOTES: (continued)

- This package is designed to be soldered to a thermal pad on the board. For more information, see Texas Instruments literature number SLUA271 ([www.ti.com/lit/slua271](http://www.ti.com/lit/slua271)).
- Vias are optional depending on application, refer to device data sheet. If any vias are implemented, refer to their locations shown on this view. It is recommended that vias under paste be filled, plugged or tented.

EXAMPLE STENCIL DESIGN

KLA0009A

TOLL - 2.35 mm max height

TO LEADLESS

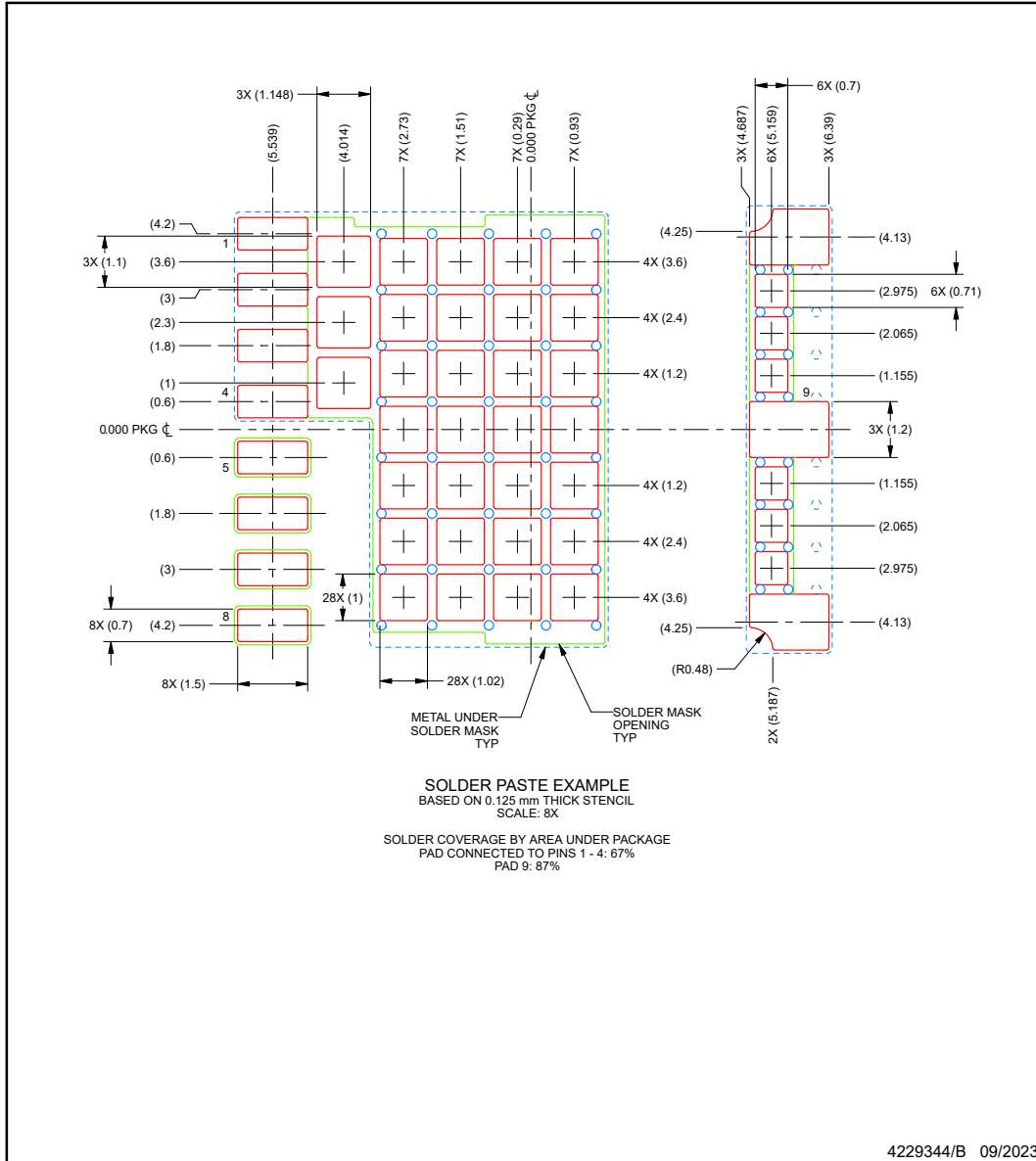

NOTES: (continued)

6. Laser cutting apertures with trapezoidal walls and rounded corners may offer better paste release. IPC-7525 may have alternate design recommendations.

ADVANCE INFORMATION

## 12.1 Tape and Reel Information

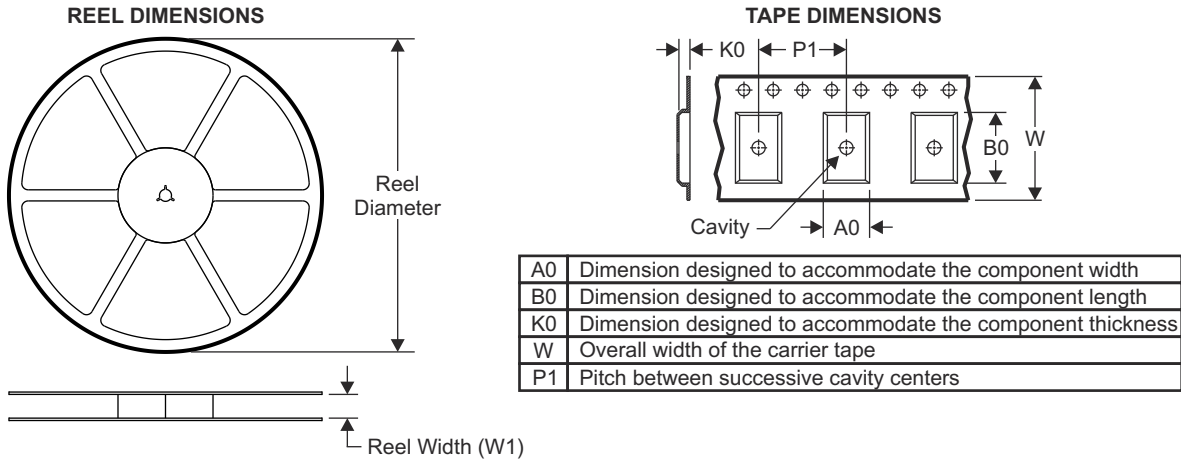

### QUADRANT ASSIGNMENTS FOR PIN 1 ORIENTATION IN TAPE

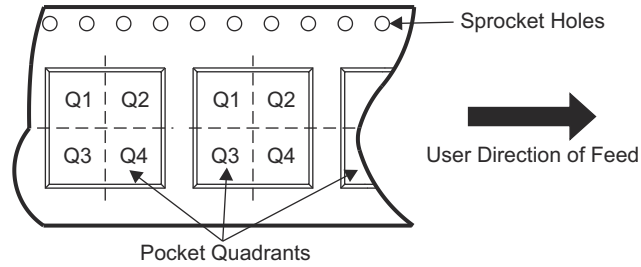

Device	Package Type	Package Drawing	Pins	SPQ	Reel Diameter (mm)	Reel Width W1 (mm)	A0 (mm)	B0 (mm)	K0 (mm)	P1 (mm)	W (mm)	Pin1 Quadrant
XLMG3650R035KLAT	TO	KLA	9	2000	330.0	24.4	10.20	11.98	2.6	12.0	21.0	Q2

ADVANCE INFORMATION



TAPE AND REEL BOX DIMENSIONS

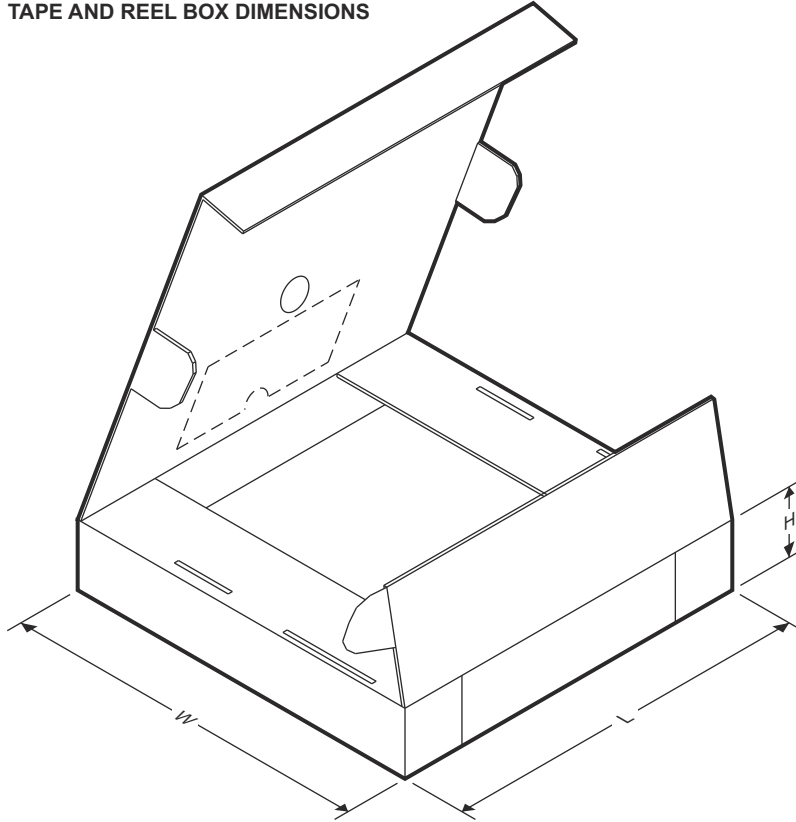

Device	Package Type	Package Drawing	Pins	SPQ	Length (mm)	Width (mm)	Height (mm)
XLMG3650R035KLAT	TO	KLA	9	2000	356.0	356.0	45.0

ADVANCE INFORMATION

**PACKAGING INFORMATION**

Orderable Device	Status (1)	Package Type	Package Drawing	Pins	Package Qty	Eco Plan (2)	Lead finish/ Ball material (6)	MSL Peak Temp (3)	Op Temp (°C)	Device Marking (4/5)	Samples
XLMG3650R035KLAT	ACTIVE	TO	KLA	9	250	TBD	Call TI	Call TI	-40 to 175		Samples

(1) The marketing status values are defined as follows:

**ACTIVE:** Product device recommended for new designs.

**LIFEBUY:** TI has announced that the device will be discontinued, and a lifetime-buy period is in effect.

**NRND:** Not recommended for new designs. Device is in production to support existing customers, but TI does not recommend using this part in a new design.

**PREVIEW:** Device has been announced but is not in production. Samples may or may not be available.

**OBSELETE:** TI has discontinued the production of the device.

(2) **RoHS:** TI defines "RoHS" to mean semiconductor products that are compliant with the current EU RoHS requirements for all 10 RoHS substances, including the requirement that RoHS substance do not exceed 0.1% by weight in homogeneous materials. Where designed to be soldered at high temperatures, "RoHS" products are suitable for use in specified lead-free processes. TI may reference these types of products as "Pb-Free".

**RoHS Exempt:** TI defines "RoHS Exempt" to mean products that contain lead but are compliant with EU RoHS pursuant to a specific EU RoHS exemption.

**Green:** TI defines "Green" to mean the content of Chlorine (Cl) and Bromine (Br) based flame retardants meet JS709B low halogen requirements of <=1000ppm threshold. Antimony trioxide based flame retardants must also meet the <=1000ppm threshold requirement.

(3) MSL, Peak Temp. - The Moisture Sensitivity Level rating according to the JEDEC industry standard classifications, and peak solder temperature.

(4) There may be additional marking, which relates to the logo, the lot trace code information, or the environmental category on the device.

(5) Multiple Device Markings will be inside parentheses. Only one Device Marking contained in parentheses and separated by a "-" will appear on a device. If a line is indented then it is a continuation of the previous line and the two combined represent the entire Device Marking for that device.

(6) Lead finish/Ball material - Orderable Devices may have multiple material finish options. Finish options are separated by a vertical ruled line. Lead finish/Ball material values may wrap to two lines if the finish value exceeds the maximum column width.

**Important Information and Disclaimer:**The information provided on this page represents TI's knowledge and belief as of the date that it is provided. TI bases its knowledge and belief on information provided by third parties, and makes no representation or warranty as to the accuracy of such information. Efforts are underway to better integrate information from third parties. TI has taken and continues to take reasonable steps to provide representative and accurate information but may not have conducted destructive testing or chemical analysis on incoming materials and chemicals. TI and TI suppliers consider certain information to be proprietary, and thus CAS numbers and other limited information may not be available for release.

In no event shall TI's liability arising out of such information exceed the total purchase price of the TI part(s) at issue in this document sold by TI to Customer on an annual basis.

## 重要なお知らせと免責事項

テキサス・インスツルメンツは、技術データと信頼性データ(データシートを含みます)、設計リソース(リファレンス デザインを含みます)、アプリケーションや設計に関する各種アドバイス、Web ツール、安全性情報、その他のリソースを、欠陥が存在する可能性のある「現状のまま」提供しており、商品性および特定目的に対する適合性の黙示保証、第三者の知的財産権の非侵害保証を含むいかなる保証も、明示的または黙示的にかかわらず拒否します。

これらのリソースは、テキサス・インスツルメンツ製品を使用する設計の経験を積んだ開発者への提供を意図したものです。(1) お客様のアプリケーションに適したテキサス・インスツルメンツ製品の選定、(2) お客様のアプリケーションの設計、検証、試験、(3) お客様のアプリケーションに該当する各種規格や、その他のあらゆる安全性、セキュリティ、規制、または他の要件への確実な適合に関する責任を、お客様のみが単独で負うものとし、ます。

上記の各種リソースは、予告なく変更される可能性があります。これらのリソースは、リソースで説明されているテキサス・インスツルメンツ製品を使用するアプリケーションの開発の目的でのみ、テキサス・インスツルメンツはその使用をお客様に許諾します。これらのリソースに関して、他の目的で複製することや掲載することは禁止されています。テキサス・インスツルメンツや第三者の知的財産権のライセンスが付与されている訳ではありません。お客様は、これらのリソースを自身で使用した結果発生するあらゆる申し立て、損害、費用、損失、責任について、テキサス・インスツルメンツおよびその代理人を完全に補償するものとし、テキサス・インスツルメンツは一切の責任を拒否します。

テキサス・インスツルメンツの製品は、[テキサス・インスツルメンツの販売条件](#)、または [ti.com](https://www.ti.com) やかかるテキサス・インスツルメンツ製品の関連資料などのいずれかを通じて提供する適用可能な条項の下で提供されています。テキサス・インスツルメンツがこれらのリソースを提供することは、適用されるテキサス・インスツルメンツの保証または他の保証の放棄の拡大や変更を意味するものではありません。

お客様がいかなる追加条項または代替条項を提案した場合でも、テキサス・インスツルメンツはそれらに異議を唱え、拒否します。

郵送先住所：Texas Instruments, Post Office Box 655303, Dallas, Texas 75265  
Copyright © 2025, Texas Instruments Incorporated