

ISOx5 絶縁型 3.3V 半二重および全二重 RS-485 トランシーバ

1 特長

- TIA/EIA RS-485 の要件を満たす (または上回る) 性能
- 1/8 ユニット負荷 - 1 個のバスに最大 256 個のノード
- 最大 1Mbps の信号速度
- サーマル・シャットダウン保護
- 16pF の低バス容量 (標準値)
- 50kV/μs の標準過渡耐性
- バスの開放、短絡、またはアイドル時のフェイルセーフを備えるレシーバ
- 3.3V 入力は 5V 許容
- 安全および規制当局の承認
 - DIN EN IEC 60747-17 (VDE 0884-17) に準拠した 4000 V_{PK} V_{IOTM}, 560 V_{PK} V_{IORM}
 - UL 1577 に準拠した 2500 V_{RMS} 絶縁定格
 - CSA 62368-1 に準拠した 2500 V_{RMS} 絶縁定格

2 アプリケーション

- セキュリティ・システム
- 化学物質の製造
- ファクトリ・オートメーション
- モーターおよびモーション制御
- HVAC およびビルディング・オートメーション・ネットワーク
- ネットワーク接続セキュリティ・ステーション

3 概要

ISO15 は TIA/EIA 485/422 アプリケーション向けの絶縁型半二重差動ライン・トランシーバ、ISO35 は絶縁型全二重差動ライン・ドライバ / レシーバです。周囲温度の定格は、ISO15 および ISO35 では -40°C ~ 85°C と規定されており、ISO15M および ISO35M では -55°C ~ 125°C に拡張されています。

これらのデバイスは、はるかに大きな同相電圧範囲を許容するようにグラウンド・ループが切断されているため、長い伝送ラインに理想的です。デバイスの対称型バリアは、バスライン・トランシーバとロジックレベル・インターフェイスとの間で、4000 V_{PK} (VDE に準拠) および 2500 V_{RMS} (UL および CSA に準拠) の絶縁を行うことがテスト済みです。

ケーブル接続されたすべての I/O は、各種ノイズ源からの電氣的ノイズの過渡現象にさらされる可能性があります。このようなノイズ過渡は、十分な大きさで持続時間を持つ場合、トランシーバや隣接する敏感な回路に損傷を与える可能性があります。これらの絶縁型デバイスは、保護を大幅に強化し、高価な制御回路の損傷リスクを低減できます。

製品情報⁽¹⁾

部品番号	パッケージ	本体サイズ (公称)
ISO15	SOIC (16)	10.30mm × 7.50mm
ISO35		

- (1) 利用可能なすべてのパッケージについては、データシートの末尾にある注文情報を参照してください。

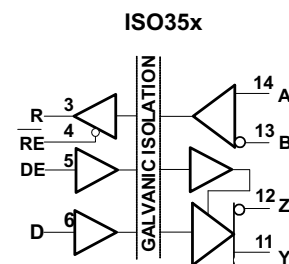
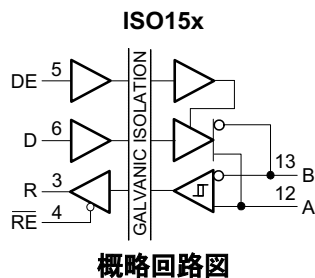



Table of Contents

1 特長	1	7 Parameter Measurement Information	14
2 アプリケーション	1	8 Detailed Description	18
3 概要	1	8.1 Overview.....	18
4 Revision History	2	8.2 Functional Block Diagrams.....	18
5 Pin Configuration and Functions	4	8.3 Device Functional Modes.....	18
6 Specifications	5	9 Application and Implementation	22
6.1 Absolute Maximum Ratings.....	5	9.1 Application Information.....	22
6.2 ESD Ratings.....	5	9.2 Typical Application.....	22
6.3 Recommended Operating Conditions.....	5	10 Layout	24
6.4 Thermal Information.....	7	10.1 Layout Guidelines.....	24
6.5 Power Ratings.....	7	10.2 Layout Example.....	25
6.6 Insulation Specifications.....	7	11 Device and Documentation Support	26
6.7 Safety-Related Certifications.....	8	11.1 Documentation Support.....	26
6.8 Safety Limiting Values.....	8	11.2 ドキュメントの更新通知を受け取る方法.....	26
6.9 Electrical Characteristics: Driver.....	9	11.3 サポート・リソース.....	26
6.10 Electrical Characteristics: Receiver.....	9	11.4 Trademarks.....	26
6.11 Supply Current.....	11	11.5 静電気放電に関する注意事項.....	26
6.12 Switching Characteristics: Driver.....	12	11.6 用語集.....	26
6.13 Switching Characteristics: Receiver.....	12	13 Mechanical, Packaging, and Orderable Information	26
6.14 Insulation Characteristics Curves.....	13		
6.15 Typical Characteristics.....	13		

4 Revision History

資料番号末尾の英字は改訂を表しています。その改訂履歴は英語版に準じています。

Changes from Revision G (March 2015) to Revision H (August 2023)	Page
• CSA 規格を CSA 62368-1 に更新、VDE 規格を DIN EN IEC 60747-17 (VDE 0884-17) に更新.....	1
• ドキュメント全体にわたって表、図、相互参照の採番方法を更新.....	1
• Updated Thermal Characteristics, Safety Limiting Values, and Thermal Derating Curves to provide more accurate system-level thermal calculations.....	7
Changes from Revision F (January 2012) to Revision G (October 2014)	Page
• 「ピン構成および機能」セクション、「ESD 定格」表、「機能説明」セクション、「デバイスの機能モード」セクション、「アプリケーションと実装」セクション、「電源に関する推奨事項」セクション、「レイアウト」セクション、「デバイスおよびドキュメントのサポート」セクション、「メカニカル、パッケージ、および注文情報」セクションを追加.....	1
• VDE 規格を DIN V VDE V 0884-10 (VDE V 0884-10):2006-12 に変更.....	1
Changes from Revision E (April 2010) to Revision F (January 2012)	Page
• 「特長」の項目を「IEC 60747-5-2 (VDE 0884, Rev 2) に準拠した 4000 V _{peak} 、560 V _{peak} V _{IORM} 」を「IEC 60747-5-2 (VDE 0884, Rev 2) に準拠した 4000 V _{PK} V _{IOTM} 、560 V _{PK} V _{IORM} 」に変更.....	1
• 「概要」にある「デバイスの対称型絶縁バリアは、.....テスト済みです」という記述を「デバイスの対称型絶縁バリアは、...4000 V _{PK} (VDE に準拠) および 2500 V _{RMS} (UL および CSA に準拠) の絶縁を行うことがテスト済みです」に変更.....	1
• Updated electrical and switching characteristics to match device performance.....	9
Changes from Revision D (March 2009) to Revision E (April 2010)	Page
• データシートにデバイス ISO15M および ISO35M を追加.....	1
• 「概要」にある「ISO15 および ISO35 は -40°C~85°Cでの使用が認定済みです」という記述を「周囲温度の定格は、ISO15 および ISO35 では -40°C~85°Cと規定されており、ISO15M および ISO35M では -55°C~125°Cに拡張されています」に変更.....	1
• Added the Driver output pins Note for  7-1 through  7-4.....	14

- Changed the Driver output pins Note for [図 7-5](#) through [図 7-6](#) 14

Changes from Revision B (July 2008) to Revision C (December 2008) Page

- IEC による承認の項目を追加..... 1

Changes from Revision A (June 2008) to Revision B (July 2008) Page

- 以下のように変更:「4000 Vpeak 絶縁」から「UL 1577 および IEC 60747-5-2 (VDE 0884, Rev 2) に準拠した 4000 Vpeak 絶縁、560 Vpeak VIORM」..... 1
- Changed [図 7-13](#), Full-Duplex Common-Mode Transient Immunity Test Circuit..... 14

5 Pin Configuration and Functions

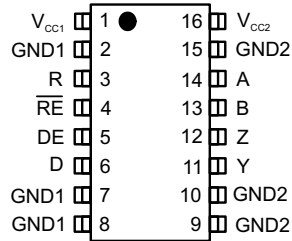

**图 5-1. ISO35x DW Package
16-Pin SOIC
Top View**

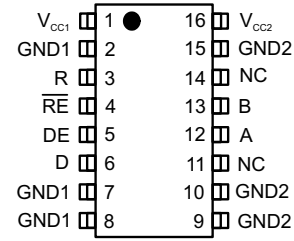

**图 5-2. ISO15x DW Package
16-Pin SOIC
Top View**

表 5-1. Pin Functions

NAME	PIN		I/O	DESCRIPTION
	ISO15x NO.	ISO35x NO.		
A	12	14	I/O	ISO15x: Noninverting bus input or output
			I	ISO35x: Noninverting bus input
B	13	13	I/O	ISO15x: Inverting bus input or output
			I	ISO35x: Inverting bus input
D	6	6	I	Driver input
DE	5	5	I	Driver logic-high enable input
GND1	2,7,8	2,7,8	—	Logic side ground; internally connected
GND2	9,10,15	9,10,15	—	Bus side ground; internally connected
NC	11,14	—	—	Not connected internally; may be left floating
R	3	3	O	Receiver output
RE	4	4	I	Receiver logic-low enable
V _{CC1}	1	1	—	Logic side power supply
V _{CC2}	16	16	—	Bus side power supply
Y	—	11	O	Noninverting bus output
Z	—	12	O	Inverting bus output

6 Specifications

6.1 Absolute Maximum Ratings

Over operating free-air temperature range (unless otherwise noted)⁽¹⁾

		MIN	MAX	UNIT
V _{CC1}	Supply voltage, side 1 ⁽²⁾	-0.3	6	V
V _{CC2}	Supply voltage, side 2 ⁽²⁾	-0.3	6	V
V _O	Voltage at any bus I/O terminal	-9	14	V
V _{it}	Voltage input, transient pulse, A, B, Y, and Z (through 100Ω, see Figure 13)	-50	50	V
V _I	Voltage input at any D, DE or RE terminal	-0.5	6	V
I _O	Receiver output current	-10	10	mA
T _J	Junction temperature		150	°C
T _{STG}	Storage temperature	-65	150	°C

- (1) Stresses beyond those listed under *Absolute Maximum Ratings* may cause permanent damage to the device. These are stress ratings only, which do not imply functional operation of the device at these or any other conditions beyond those indicated under *Recommended Operating Conditions*. Exposure to absolute-maximum-rated conditions for extended periods may affect device reliability.
- (2) All voltage values except differential I/O bus voltages are with respect to network ground terminal and are peak voltage values.

6.2 ESD Ratings

			VALUE	UNIT
V _(ESD)	Human body model (HBM), per ANSI/ESDA/JEDEC JS-001 ⁽¹⁾	Bus pins and GND1	±6000	V
V _(ESD)	Human body model (HBM), per ANSI/ESDA/JEDEC JS-001 ⁽¹⁾	Bus pins and GND2	±16000	V
V _(ESD)	Human body model (HBM), per ANSI/ESDA/JEDEC JS-001 ⁽¹⁾	All pins	±4000	V
V _(ESD)	Charged device model (CDM), per JEDEC specification JESD22-C101, all pins ⁽²⁾		±1000	V
V _(ESD)	Machine model ANSI/ESDS5.2-1996		±200	V

- (1) JEDEC document JEP155 states that 500-V HBM allows safe manufacturing with a standard ESD control process.
- (2) JEDEC document JEP157 states that 250-V CDM allows safe manufacturing with a standard ESD control process.

6.3 Recommended Operating Conditions

		MIN	TYP	MAX	UNIT
V _{CC1}	Supply Voltage, Side 1	3.15	3.3	3.6	V
V _{CC2}	Supply Voltage, Side 2	3.15	3.3	3.6	V
V _{OC}	Common Mode voltage at any bus terminal: A or B	-7		12	V
V _{IH}	High-level input voltage (D, DE, \overline{RE} inputs)	2		V _{CC1}	V
V _{IL}	Low-level input voltage (D, DE, \overline{RE} inputs)	0		0.8	V
V _{ID}	Differential input voltage, A with respect to B	-12		12	V
R _L	Differential load resistance	54	60		Ω
I _O	Output current, Driver	-60		60	mA
1/t _{UI}	Signaling rate ISO15x and ISO35x			1	Mbps
T _A	Operating ambient temperature (ISO15 and ISO35)	-40	25	85	°C
	Operating ambient temperature (ISO15M and ISO35M)	-55	25	125	°C

		MIN	TYP	MAX	UNIT
T _J	Operating junction temperature (ISO15 and ISO35)	-40		150	°C
	Operating junction temperature (ISO15M and ISO35M)	-55		150	°C

6.4 Thermal Information

THERMAL METRIC ⁽¹⁾		ISO15, ISO35	UNIT
		DW (SOIC)	
		16 PINS	
R _{θJA}	Junction-to-ambient thermal resistance	79.6	°C/W
R _{θJC(top)}	Junction-to-case (top) thermal resistance	39.7	°C/W
R _{θJB}	Junction-to-board thermal resistance	44.6	°C/W
ψ _{JT}	Junction-to-top characterization parameter	11.8	°C/W
ψ _{JB}	Junction-to-board characterization parameter	44	°C/W
R _{θJC(bot)}	Junction-to-case (bottom) thermal resistance	—	°C/W

(1) For more information about traditional and new thermal metrics, see the [Semiconductor and IC Package Thermal Metrics application report](#).

6.5 Power Ratings

PARAMETER	TEST CONDITIONS	MIN	TYP	MAX	UNIT
P _D	Maximum power dissipation (both sides) V _{CC1} = V _{CC2} = 3.6 V, T _J = 150°C, C _L = 15 pF, Input a 0.5 MHz 50% duty cycle square wave			220	mW

6.6 Insulation Specifications

PARAMETER		TEST CONDITIONS	VALUE DW-16	UNIT
CLR	External clearance ⁽¹⁾	Shortest terminal-to-terminal distance through air	8	mm
CPG	External creepage ⁽¹⁾	Shortest terminal-to-terminal distance across the package surface	8	mm
DTI	Distance through the insulation	Minimum internal gap (internal clearance)	8	um
CTI	Comparative tracking index	DIN EN 60112 (VDE 0303-11); IEC 60112	>400	V
	Material group	According to IEC 60664-1	II	
	Overvoltage category per IEC 60664-1	Rated mains voltage ≤ 150 V _{RMS}	I-IV	
		Rated mains voltage ≤ 300 V _{RMS}	I-III	
DIN EN IEC 60747-17 (VDE 0884-17) ⁽²⁾				
V _{IORM}	Maximum repetitive peak isolation voltage	AC voltage (bipolar)	560	V _{PK}
V _{IOTM}	Maximum transient isolation voltage	V _{TEST} = V _{IOTM} , t = 60 s (qualification); V _{TEST} = 1.2 x V _{IOTM} , t = 1 s (100% production)	4000	V _{PK}
q _{pd}	Apparent charge ⁽³⁾	Method b; At routine test (100% production) V _{ini} = 1.2 x V _{IOTM} , t _{ini} = 1 s; V _{pd(m)} = 1.5 x V _{IORM} , t _m = 1 s	≤5	pC
C _{IO}	Barrier capacitance, input to output ⁽⁴⁾	V _{IO} = 0.4 x sin(2πft), f = 1 MHz	2	pF
C _I	Input capacitance to ground	V _I = V _{CC} /2 + 0.4×sin(2πft), f = 1 MHz, V _{CC} = 3.3 V	2	pF
R _{IO}	Isolation resistance ⁽⁴⁾	V _{IO} = 500 V, T _A = 25°C	>10 ¹²	Ω
		V _{IO} = 500 V, T _S = 150°C	>10 ⁹	
	Pollution degree		2	
	Climatic Category		40/125/21	
UL 1577				

PARAMETER		TEST CONDITIONS	VALUE	UNIT
			DW-16	
V _{ISO}	Maximum withstanding isolation voltage	V _{TEST} = V _{ISO} , t = 60 s (qualification), V _{TEST} = 1.2 x V _{ISO} , t = 1 s (100% production)	2500	V _{RMS}

- Creepage and clearance requirements should be applied according to the specific equipment isolation standards of an application. Care should be taken to maintain the creepage and clearance distance of a board design to ensure that the mounting pads of the isolator on the printed-circuit board do not reduce this distance. Creepage and clearance on a printed-circuit board become equal in certain cases. Techniques such as inserting grooves and/or ribs on a printed-circuit board are used to help increase these specifications.
- This coupler is suitable for *basic electrical insulation* only within the safety ratings. Compliance with the safety ratings shall be ensured by means of suitable protective circuits.
- Apparent charge is electrical discharge caused by a partial discharge (pd).
- All pins on each side of the barrier tied together creating a two-terminal device.

6.7 Safety-Related Certifications

VDE	CSA	UL
Certified according to DIN EN IEC 60747-17 (VDE 0884-17)	Certified according to IEC 60950-1 and IEC 62368-1	Certified according to UL 1577 Component Recognition Program
Basic insulation, 4000 V _{PK} Maximum transient isolation voltage, 560 V _{PK} Maximum repetitive peak isolation voltage	2500 V _{RMS} Isolation rating, Reinforced insulation per CSA 60950-1 and IEC 60950-1 148V _{RMS} working voltage; Basic insulation per CSA 62368-1 and IEC 62368-1 300V _{RMS} working voltage	Single protection, 2500 V _{RMS}
Certificate number: 40047657	Master contract number: 220991	File number: E181974

6.8 Safety Limiting Values

Safety limiting⁽¹⁾ intends to minimize potential damage to the isolation barrier upon failure of input or output circuitry.

PARAMETER		TEST CONDITIONS	MIN	TYP	MAX	UNIT
DW-16 PACKAGE						
I _S	Safety input, output, or supply current	R _{θJA} = 79.6°C/W, V _I = 3.6 V, T _J = 150°C, T _A = 25°C.			436	mA
T _S	Maximum safety temperature				150	°C

- The maximum safety temperature, T_S, has the same value as the maximum junction temperature, T_J, specified for the device. The I_S and P_S parameters represent the safety current and safety power respectively. The maximum limits of I_S and P_S should not be exceeded. These limits vary with the ambient temperature, T_A.
The junction-to-air thermal resistance, R_{θJA}, in the table is that of a device installed on a high-K test board for leaded surface-mount packages. Use these equations to calculate the value for each parameter:
T_J = T_A + R_{θJA} × P, where P is the power dissipated in the device.
T_{J(max)} = T_S = T_A + R_{θJA} × P_S, where T_{J(max)} is the maximum allowed junction temperature.
P_S = I_S × V_I, where V_I is the maximum input voltage.

6.9 Electrical Characteristics: Driver

All typical specs are at $V_{CC1}=3.3V$, $V_{CC2}=5V$, $T_A=27^\circ C$, (Min/Max specs are over recommended operating conditions unless otherwise noted)

PARAMETER		TEST CONDITIONS	MIN	TYP	MAX	UNIT
V _{OD}	Driver differential-output voltage magnitude	I _O = 0 mA, no load	2.5		V _{CC2}	V
		R _L = 54 Ω, See Figure 3	1.5	2		V
		R _L = 100 Ω (RS-422), See Figure 3	2	2.3		V
		V _{test} from -7 V to +12 V, See Figure 4	1.5			V
Δ V _{OD}	Change in differential output voltage between two states	See Figure 3 and Figure 4	-200		200	mV
V _{OC}	Common-mode output voltage	See Figure 5	1	2.6	3	V
ΔV _{OC(SS)}	change in steady-state common-mode output voltage between two states	See Figure 5	-100		100	mV
V _{OC(PP)}	Peak-to-peak common-mode output voltage	See Figure 5		0.5		V
I _I	Input current	D, DE, V _I at 0 V or V _{CC1}	-10		10	μA
I _{OZ}	High-impedance state output current	ISO15 See receiver input current				
		ISO35 V _Y or V _Z = 12 V			90	μA
		ISO35 V _Y or V _Z = 12 V, V _{CC} = 0			90	μA
		ISO35 V _Y or V _Z = -7 V	-10			μA
		ISO35 V _Y or V _Z = -7 V, V _{CC} = 0	-10			μA
I _{OS}	Short-circuit output current	V _A or V _B at -7 V	-250		250	mA
		V _A or V _B at 12 V	-250		250	mA
C _{OD}	Differential output capacitance	V _I = 0.4 sin(4E6πt) + 0.5 V, DE at 0 V		16		pF
CMTI	Common-mode transient immunity	V _I = V _{CC} or 0 V, See Figure 14 and Figure 15	25	50		kV/μs

6.10 Electrical Characteristics: Receiver

All typical specs are at $V_{CC1}=3.3V$, $V_{CC2}=5V$, $T_A=27^\circ C$, (Min/Max specs are over recommended operating conditions unless otherwise noted)

PARAMETER		TEST CONDITIONS	MIN	TYP	MAX	UNIT
V _{IT+}	Positive-going input threshold voltage	I _O = -8 mA			-20	mV
V _{IT-}	Negative-going input threshold voltage	I _O = 8 mA	-200			mV
V _{hys}	Input hysteresis (V _{IT+} - V _{IT-})			50		mV
V _O	Output Voltage	V _{ID} = 200mV, I _O = -8mA	2.4			V
		V _{ID} = -200mV, I _O = 8mA			0.4	V
I _{OZ}	Output high-impedance current on the R pin	V _I = -7 to 12 V, Other input = 0 V	-1		1	μA
I _A or I _B	Bus input current	-55°C ≤ T _A ≤ 85°C V _A or V _B = 12 V		50	100	μA
		-55°C ≤ T _A ≤ 85°C V _A or V _B = 12 V, V _{CC} = 0		50	100	μA
		85°C ≤ T _A ≤ 125°C V _A or V _B = 12 V			200	μA
		85°C ≤ T _A ≤ 125°C V _A or V _B = 12 V, V _{CC} = 0			200	μA
		-55°C ≤ T _A ≤ 125°C V _A or V _B = -7 V	-100	-40		μA
		-55°C ≤ T _A ≤ 125°C V _A or V _B = -7 V, V _{CC} = 0	-100	-30		μA
I _{IH}	High-level input current, RE	V _{IH} = 2 V	-10			μA

All typical specs are at $V_{CC1}=3.3V$, $V_{CC2}=5V$, $T_A=27^\circ C$, (Min/Max specs are over recommended operating conditions unless otherwise noted)

PARAMETER		TEST CONDITIONS	MIN	TYP	MAX	UNIT
I_{IL}	Low-level input current, RE	$V_{IL} = 0.8 V$	-10			μA
R_{ID}	Differential input resistance	A, B	48			kohm
C_{ID}	Differential input capacitance	$V_I = 0.4 \sin(4E6\pi t) + 0.5V$, DE at 0 V		16		pF

6.11 Supply Current

Bus loaded or unloaded (over recommended operating conditions unless otherwise noted)

PARAMETER	TEST CONDITIONS	MIN	TYP	MAX	UNIT
DRIVER ENABLED, RECEIVER DISABLED					
I _{CC1}	ISO35x and ISO15x: \overline{RE} at 0 V or V _{CC} , DE at 0 V, No load (driver disabled)			8	mA
I _{CC1}	ISO35x and ISO15x: \overline{RE} at 0 V or V _{CC} , DE at V _{CC} , No load (driver enabled)			8	mA
I _{CC2}	ISO35x and ISO15x: \overline{RE} at 0 V or V _{CC} , DE at 0 V, No load (driver disabled)			15	mA
I _{CC2}	ISO35x and ISO15x: \overline{RE} at 0 V or V _{CC} , DE at V _{CC} , No Load (driver enabled)			19	mA

6.12 Switching Characteristics: Driver

All typical specs are at $V_{CC1}=3.3V$, $V_{CC2}= 3.3V$, $T_A=27^{\circ}C$, (Min/Max specs are over recommended operating conditions unless otherwise noted)

PARAMETER		TEST CONDITIONS	MIN	TYP	MAX	UNIT
500-kbps DEVICES						
t_r, t_f	Differential output rise time and fall time	ISO15M and ISO35M	120	180	350	ns
t_{PHZ}	Propagation delay, high-level-to-high-impedance output	See Figure 7			205	ns
t_{PLZ}	Propagation delay, low-level to high-impedance output	See Figure 8			330	ns
t_{PZL}	Propagation delay, standby-to-low-level output	See Figure 8			530	ns
t_{PHL}, t_{PLH}	Propagation delay	See Figure 6			340	ns
$tsk(p)$	Pulse skew ($ t_{PHL} - t_{PLH} $)	See Figure 6		6		ns
t_r, t_f	Differential output rise time and fall time	ISO15 and ISO35	120	180	300	ns
t_{PZH}	Propagation delay, high-impedance-to-high-level output	See Figure 7			530	ns

6.13 Switching Characteristics: Receiver

All typical specs are at $V_{CC1}=3.3V$, $V_{CC2}= 3.3V$, $T_A=27^{\circ}C$, (Min/Max specs are over recommended operating conditions unless otherwise noted)

PARAMETER		TEST CONDITIONS	MIN	TYP	MAX	UNIT
500-kbps DEVICES						
t_{PHL}, t_{PLH}	Propagation delay	See Figure 10			100	ns
$tsk(p)$	Pulse skew ($ t_{PHL} - t_{PLH} $)	ISO15 and ISO35			13	ns
$tsk(p)$	Pulse skew ($ t_{PHL} - t_{PLH} $)	ISO15M and ISO35M			18	ns
t_r, t_f	Differential output rise time and fall time	ISO15 and ISO35		2	4	ns
t_r, t_f	Differential output rise time and fall time	ISO15M and ISO35M		2	6	ns
t_{PHZ}, t_{PLZ}	Propagation delay, high-impedance-to-high-level output, Propagation delay, high-impedance-to-low-level output	DE at 0 V, See Figure 11 and Figure 12		13	25	ns
t_{PZH}, t_{PZL}	Propagation delay, high-level-to-high-impedance output, Propagation delay, low-level to high-impedance output	DE at 0 V, See Figure 11 and Figure 12		13	25	ns

6.14 Insulation Characteristics Curves

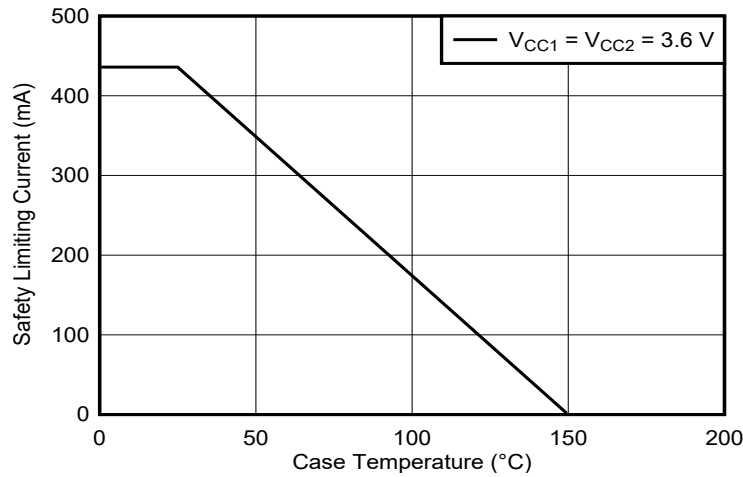

Figure 6-1. Thermal Derating Curve for Safety Limiting Power for DW-16 Package

6.15 Typical Characteristics

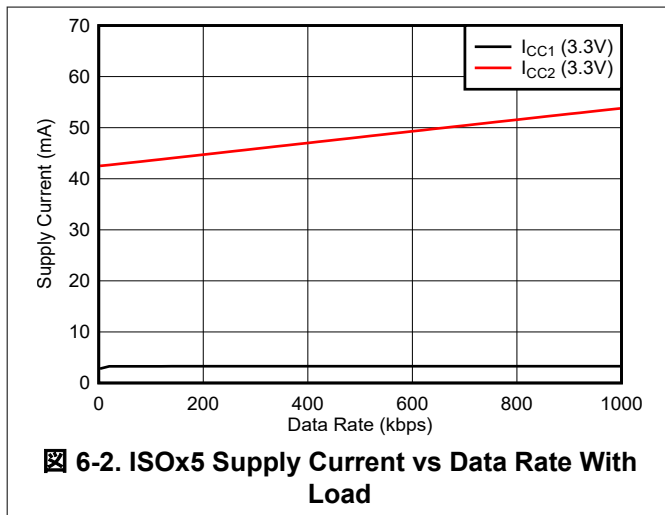

Figure 6-2. ISOx5 Supply Current vs Data Rate With Load

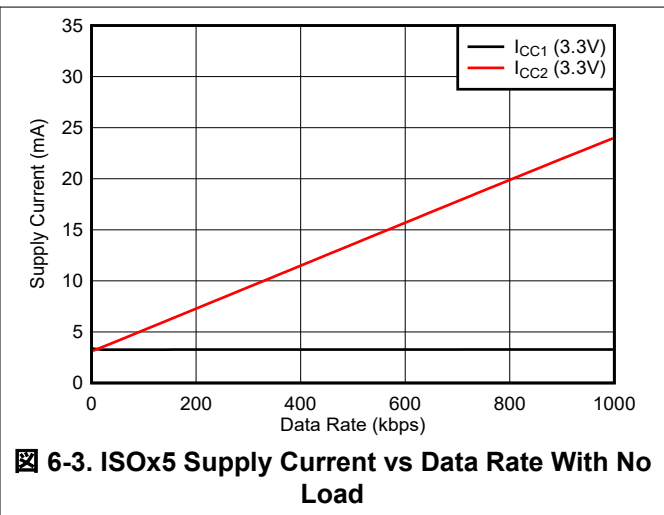
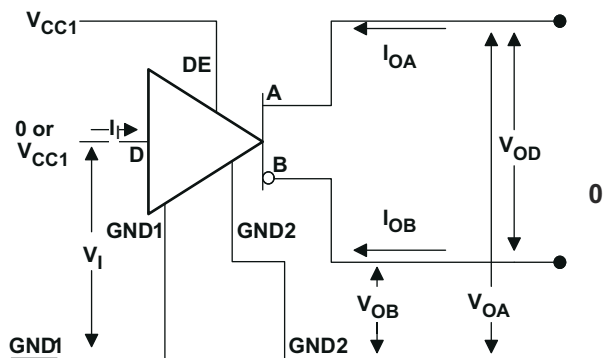
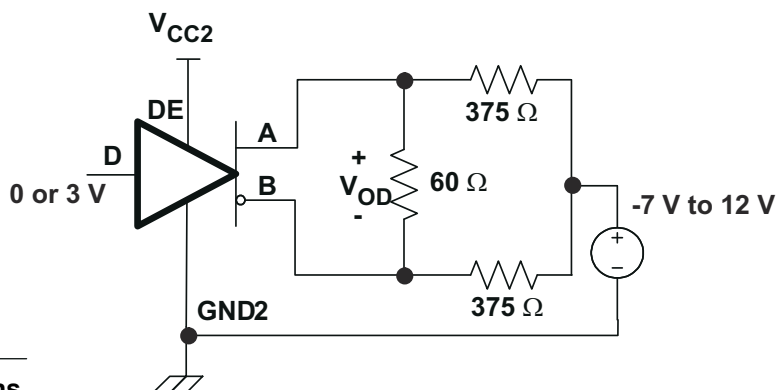

Figure 6-3. ISOx5 Supply Current vs Data Rate With No Load

7 Parameter Measurement Information



7-1. Driver V_{OD} Test and Current Definitions



7-2. Driver V_{OD} With Common-Mode Loading Test Circuit

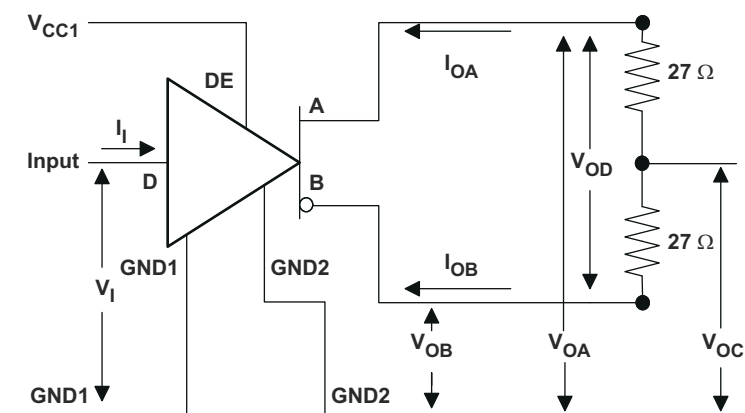

7-3. Test Circuit and Waveform Definitions for the Driver Common-Mode Output Voltage

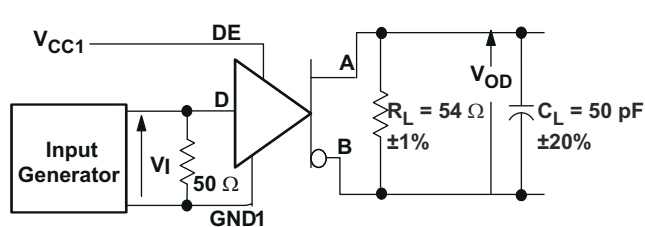

Generator: PRR = 500 kHz, 50% duty cycle, $t_r < 6\text{ns}$, $t_f < 6\text{ns}$, $Z_O = 50\ \Omega$ C_L includes fixture and Instrumentation Capacitance

7-4. Driver Switching Test Circuit and Voltage Waveforms

注

Driver output pins are A and B for the ISO15 (see 7-1 through 7-4). These correspond to ISO35 pins Y and Z

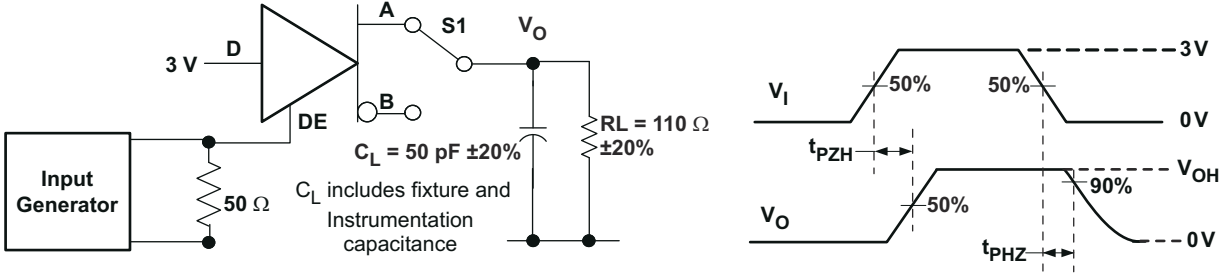

7-5. Driver High-Level Output Enable and Disable Time Test Circuit and Voltage Waveforms

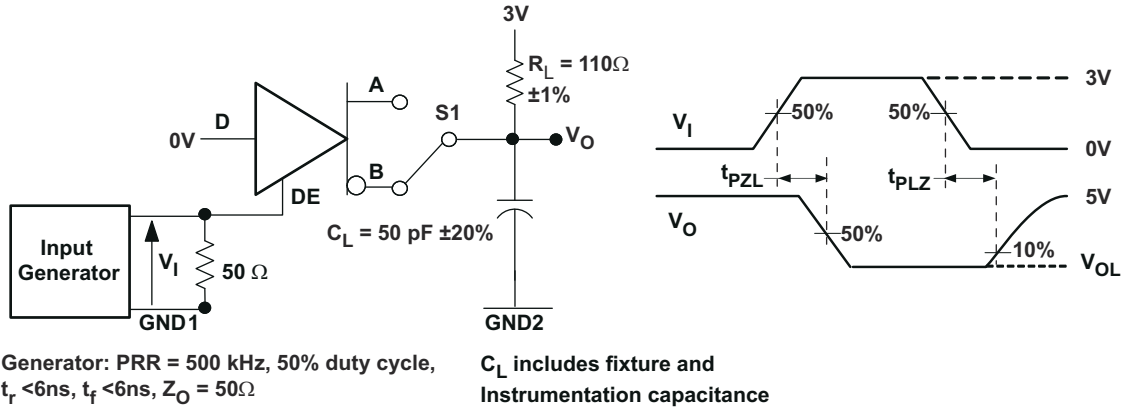

7-6. Driver Low-Level Output Enable and Disable Time Test Circuit and Voltage Waveform

注

Driver output pins are A and B for the ISO15 (see 7-5 through 7-6). These correspond to ISO35 pins Y and Z

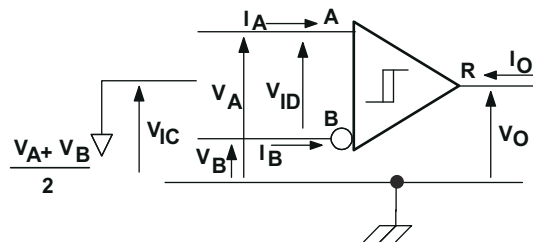

7-7. Receiver Voltage and Current Definitions

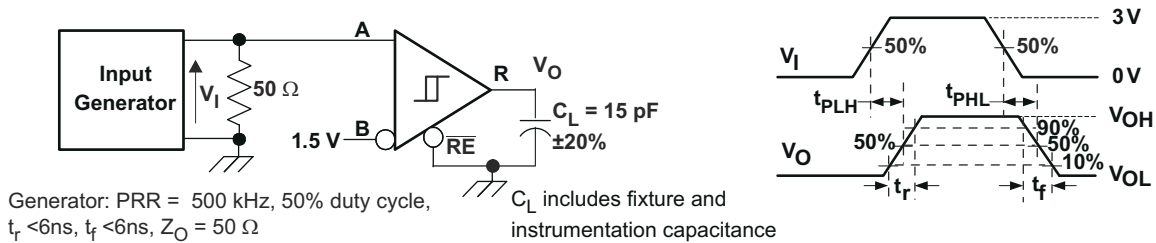

7-8. Receiver Switching Test Circuit and Waveforms



图 7-9. Receiver Enable Test Circuit and Waveforms, Data Output High



图 7-10. Receiver Enable Test Circuit and Waveforms, Data Output Low

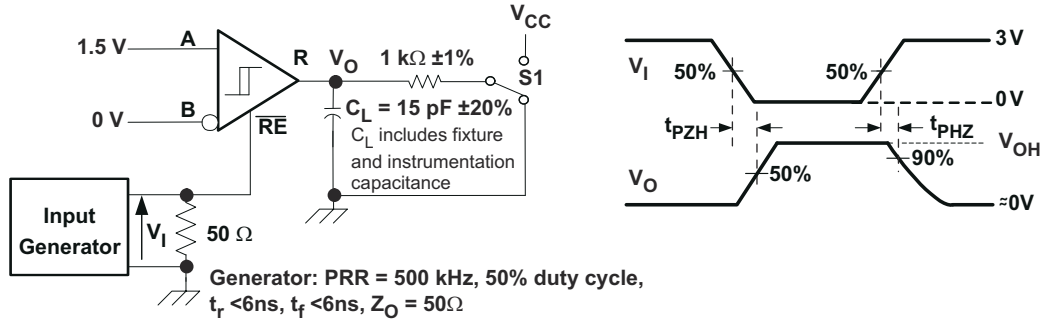

Note: This test is conducted to test survivability only.
 Data stability at the R output is not specified.

图 7-11. Transient Overvoltage Test Circuit

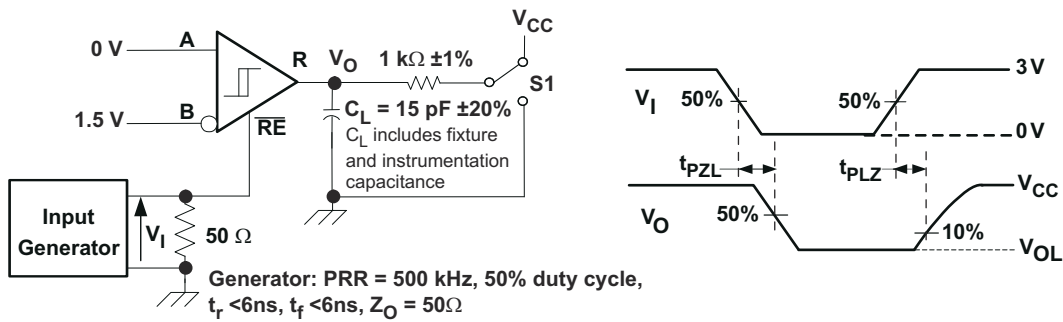
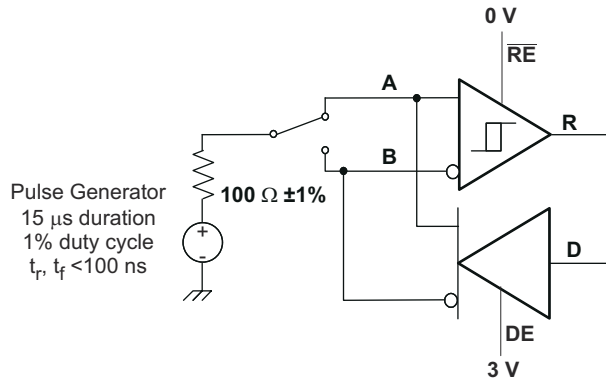
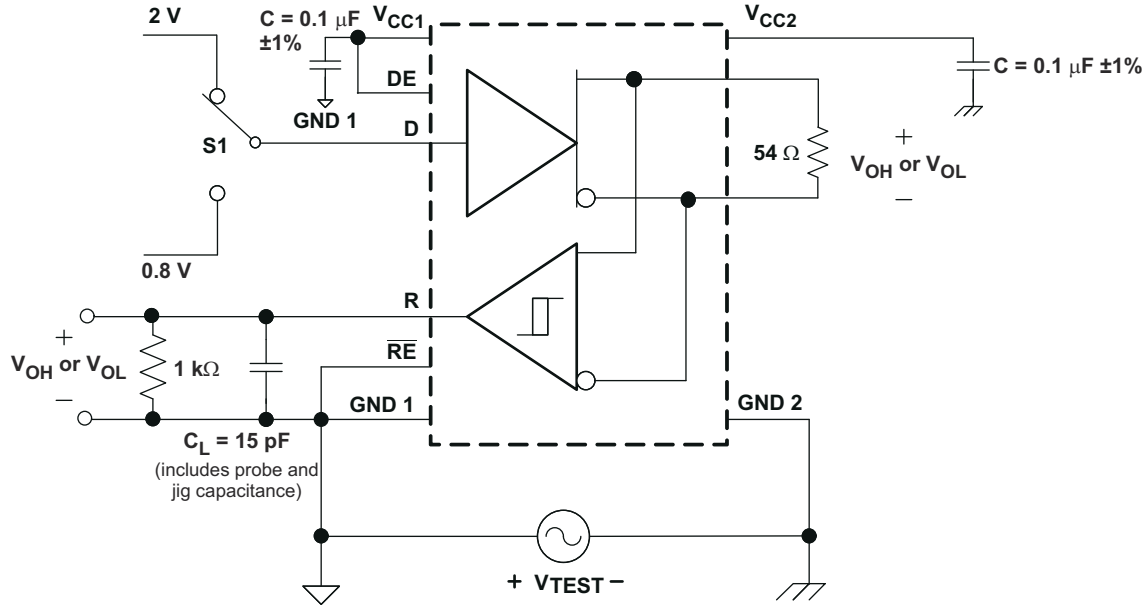

7-12. Half-Duplex Common-Mode Transient Immunity Test Circuit

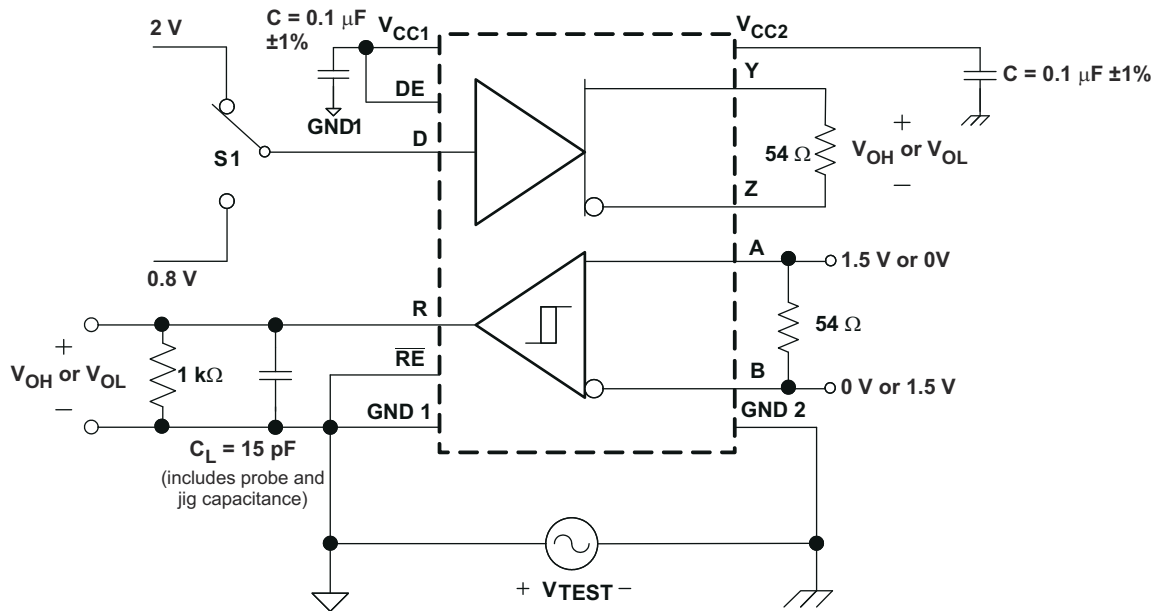

7-13. Full-Duplex Common-Mode Transient Immunity Test Circuit

8 Detailed Description

8.1 Overview

The ISO15 and ISO15M are isolated half-duplex differential line drivers and receivers while the ISO35 and ISO35M are isolated full-duplex differential line transceivers for TIA/EIA 485/422 applications. They are rated to provide galvanic isolation of up to 2500 V_{rms} for 60 sec as per the standard. They have active-high driver enables and active-low receiver enables to control the data flow.

When the driver enable pin, DE, is logic high, the differential outputs Y and Z follow the logic states at data input D. A logic high at D causes Y to turn high and Z to turn low. In this case the differential output voltage defined as $V_{OD} = V_{(Y)} - V_{(Z)}$ is positive. When D is low, the output states reverse, Z turns high, Y becomes low, and V_{OD} is negative. When DE is low, both outputs turn high-impedance. In this condition the logic state at D is irrelevant. The DE pin has an internal pulldown resistor to ground, thus when left open the driver is disabled (high-impedance) by default. The D pin has an internal pullup resistor to V_{CC}, thus, when left open while the driver is enabled, output Y turns high and Z turns low.

When the receiver enable pin, RE, is logic low, the receiver is enabled. When the differential input voltage defined as $V_{ID} = V_{(A)} - V_{(B)}$ is positive and higher than the positive input threshold, V_{IT+}, the receiver output, R, turns high. When V_{ID} is negative and less than the negative and lower than the negative input threshold, V_{IT-}, the receiver output, R, turns low. If V_{ID} is between V_{IT+} and V_{IT-} the output is indeterminate. When RE is logic high or left open, the receiver output is high-impedance and the magnitude and polarity of V_{ID} are irrelevant. Internal biasing of the receiver inputs causes the output to go failsafe-high when the transceiver is disconnected from the bus (open-circuit), the bus lines are shorted (short-circuit), or the bus is not actively driven (idle bus).

8.2 Functional Block Diagrams

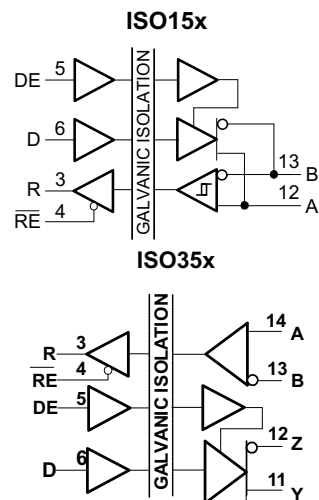

8.3 Device Functional Modes

表 8-1. Driver Function Table⁽²⁾

V _{CC1}	V _{CC2}	INPUT (D)	ENABLE INPUT (DE)	OUTPUTS ⁽¹⁾	
				Y / A	Z / B
PU	PU	H	H	H	L
PU	PU	L	H	L	H
PU	PU	X	L	Hi-Z	Hi-Z
PU	PU	X	OPEN	Hi-Z	Hi-Z
PU	PU	OPEN	H	H	L
PD	PU	X	X	Hi-Z	Hi-Z
PU	PD	X	X	Hi-Z	Hi-Z

表 8-1. Driver Function Table⁽²⁾ (continued)

V _{CC1}	V _{CC2}	INPUT (D)	ENABLE INPUT (DE)	OUTPUTS ⁽¹⁾	
				Y / A	Z / B
PD	PD	X	X	Hi-Z	Hi-Z

(1) Driver output pins are Y and Z for full-duplex devices and A & B for half-duplex devices.

(2) PU = Powered Up; PD = Powered Down; H = Logic High; L = Logic Low; X = Irrelevant, Hi-Z = High Impedance (off)

表 8-2. Receiver Function Table⁽¹⁾

V _{CC1}	V _{CC2}	DIFFERENTIAL INPUT V _{ID} = (V _A – V _B)	ENABLE (RE)	OUTPUT (R)
PU	PU	$-0.01\text{ V} \leq V_{ID}$	L	H
PU	PU	$-0.2\text{ V} < V_{ID} < -0.01\text{ V}$	L	?
PU	PU	$V_{ID} \leq -0.2\text{ V}$	L	L
PU	PU	X	H	Hi-Z
PU	PU	X	OPEN	Hi-Z
PU	PU	Open circuit	L	H
PU	PU	Short Circuit	L	H
PU	PU	Idle (terminated) bus	L	H
PD	PU	X	X	Hi-Z
PU	PD	X	L	H

(1) PU = Powered Up; PD = Powered Down; H = Logic High; L = Logic Low; X = Irrelevant, Hi-Z = High Impedance (off), ? = Indeterminate

8.3.1 Device I/O Schematics

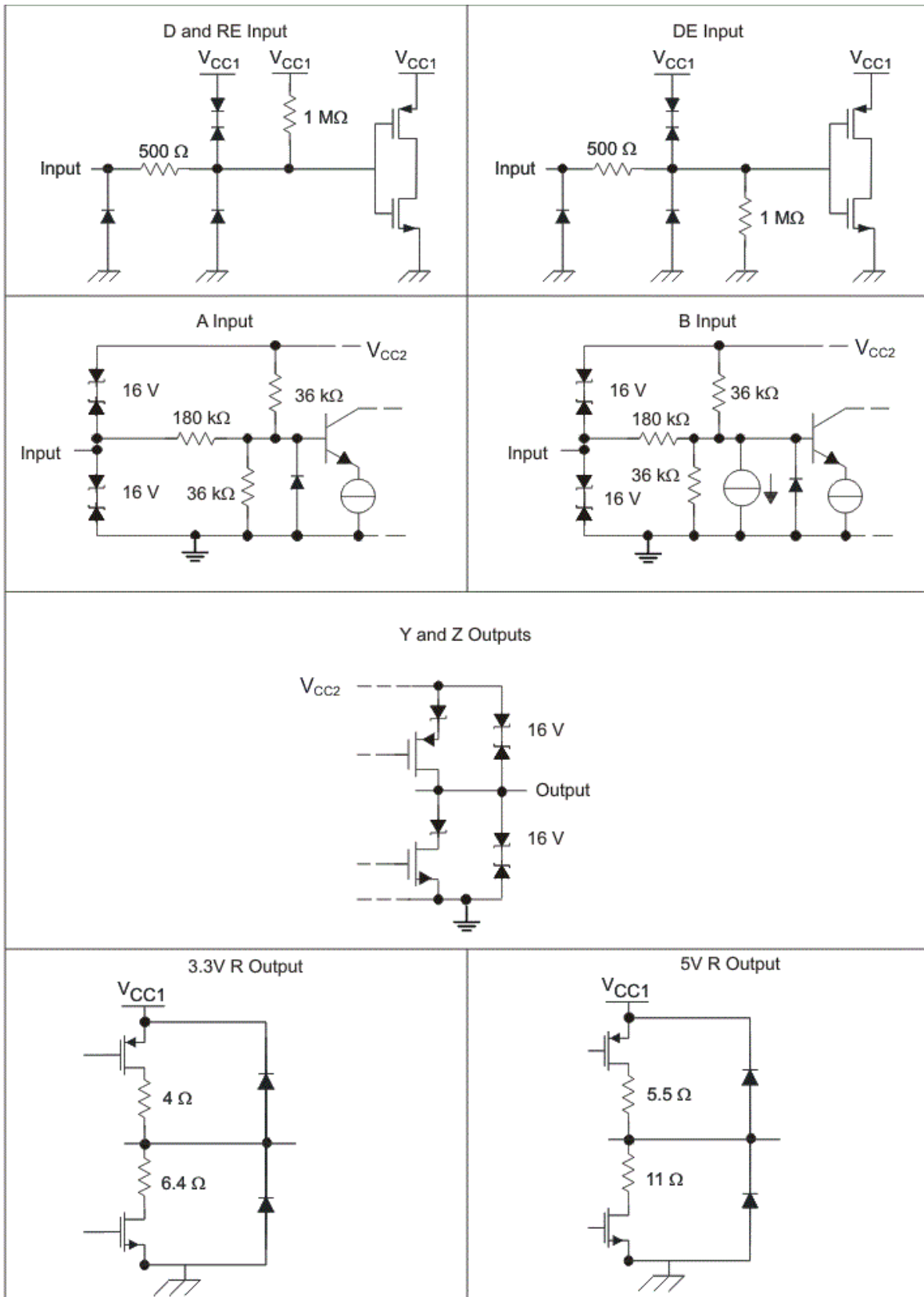

8-1. Device I/O Schematics

9 Application and Implementation

注

以下のアプリケーション情報は、TI の製品仕様に含まれるものではなく、TI ではその正確性または完全性を保証いたしません。個々の目的に対する製品の適合性については、お客様の責任で判断していただくこととなります。お客様は自身の設計実装を検証しテストすることで、システムの機能を確認する必要があります。

9.1 Application Information

The ISO15x and ISO35x family consists of RS-485 transceivers commonly used for asynchronous data transmissions. Full-duplex implementation requires two signal pairs (four wires), and allows each node to transmit data on one pair while simultaneously receiving data on the other pair. For half-duplex transmission there is only one pair which shared for both transmission and reception of data. To eliminate line reflections, each cable end is terminated with a termination resistor, $R(T)$, whose value matches the characteristic impedance, Z_0 , of the cable. This method, known as parallel termination, allows for higher data rates over longer cable length.

9.2 Typical Application

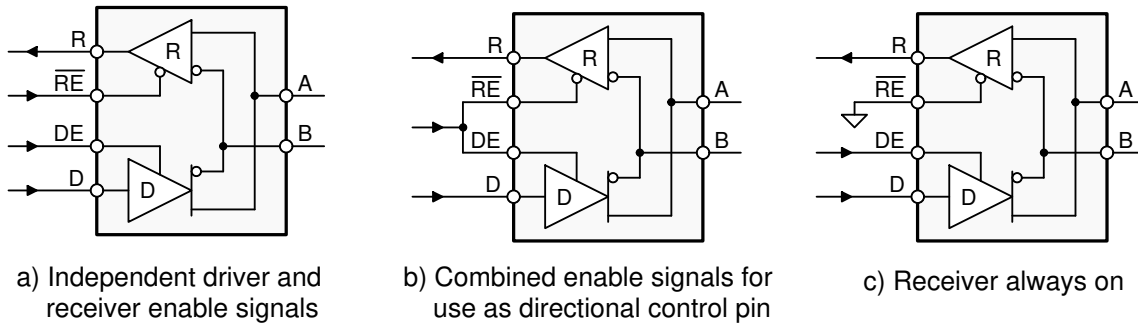

Copyright © 2016, Texas Instruments Incorporated

図 9-1. Half-Duplex Transceiver Configurations



図 9-2. Typical RS-485 Network With Full-Duplex Transceivers

9.2.1 Design Requirements

RS-485 is a robust electrical standard suitable for long-distance networking that may be used in a wide range of applications with varying requirements, such as distance, data rate, and number of nodes.

表 9-1. Design Parameters

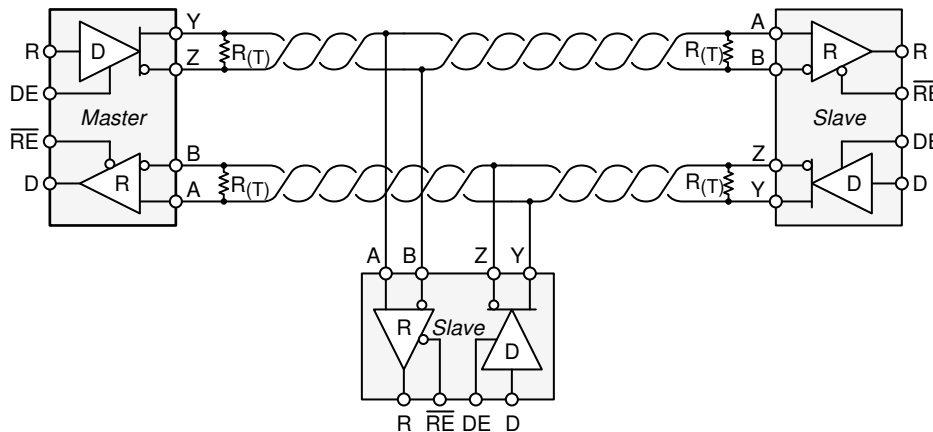
PARAMETER	VALUE
Pullup and Pulldown Resistors	1 kΩ to 10 kΩ
Decoupling Capacitors	100 nF

9.2.2 Detailed Design Procedure

There is an inverse relationship between data rate and cable length, which means the higher the data rate, the shorter the cable length; and conversely, the lower the data rate, the longer the cable length. When connecting a node to the bus, the distance between the transceiver inputs and the cable trunk, known as the stub, should be as short as possible. Stubs present a nonterminated piece of bus line which can introduce reflections as the length of the stub increases. As a general guideline, the electrical length, or round-trip delay, of a stub should be less than one-tenth of the rise time of the driver. The RS-485 standard specifies that a compliant driver must be able to driver 32 unit loads (UL), where 1 unit load represents a load impedance of approximately 12 kΩ. Because these devices consists of 1/8 UL transceivers, connecting up to 256 receivers to the bus is possible.

9.2.3 Application Curve

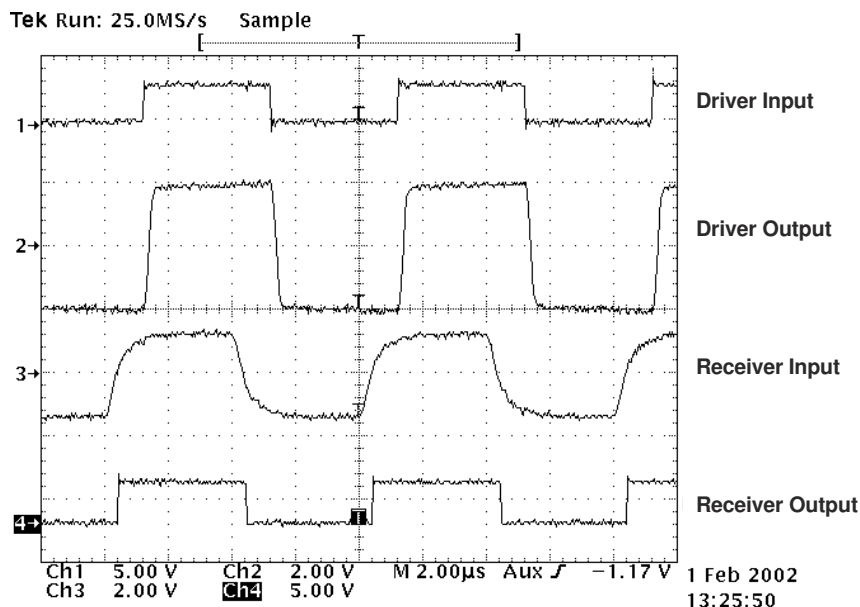

☒ 9-3. Typical Input and Output Waveforms

Power Supply Recommendations

To ensure reliable operation at all data rates and supply voltages, a 0.1- μ F bypass capacitor is recommended at input and output supply pins (V_{CC1} and V_{CC2}). The capacitors should be placed as close to the supply pins as possible. If only a single primary-side power supply is available in an application, isolated power can be generated for the secondary-side with the help of a transformer driver such as Texas Instruments' SN6501. For such applications, detailed power supply design and transformer selection recommendations are available in SN6501 data sheet ([SLLSEA0](#)).

10 Layout

10.1 Layout Guidelines

On-chip IEC-ESD protection is good for laboratory and portable equipment but never sufficient for EFT and surge transients occurring in industrial environments. Therefore robust and reliable bus node design requires the use of external transient protection devices. Because ESD and EFT transients have a wide frequency bandwidth from approximately 3-MHz to 3-GHz, high-frequency layout techniques must be applied during PCB design. A minimum of four layers is required to accomplish a low EMI PCB design (see [10-1](#)).

- Layer stacking should be in the following order (top-to-bottom): high-speed signal layer, ground plane, power plane and low-frequency signal layer.
- Place the protection circuitry close to the bus connector to prevent noise transients from penetrating the board.
- Use VCC and ground planes to provide low-inductance. High-frequency currents might follow the path of least inductance and not necessarily the path of least resistance.
- Design the protection components into the direction of the signal path. Do not force the transient currents to divert from the signal path to reach the protection device.
- Apply 100-nF to 220-nF bypass capacitors as close as possible to the VCC-pins of transceiver, UART, controller ICs on the board (see [10-1](#)).
- Use at least two vias for VCC and ground connections of bypass capacitors and protection devices to minimize effective via-inductance (see [10-1](#)).
- Use 1-k Ω to 10-k Ω pullup and pulldown resistors for enable lines to limit noise currents in these lines during transient events (see [10-1](#)).
- Insert pulse-proof resistors into the A and B bus lines if the TVS clamping voltage is higher than the specified maximum voltage of the transceiver bus pins. These resistors limit the residual clamping current into the transceiver and prevent it from latching up (see [10-1](#)).
- While pure TVS protection is sufficient for surge transients up to 1 kV, higher transients require metal-oxide varistors (MOVs) which reduce the transients to a few hundred volts of clamping voltage, and transient blocking units (TBUs) that limit transient current to less than 1 mA.
- Routing the high-speed traces on the top layer avoids the use of vias (and the introduction of their inductances) and allows for clean interconnects between the isolator and the transmitter and receiver circuits of the data link.
- Placing a solid ground plane next to the high-speed signal layer establishes controlled impedance for transmission line interconnects and provides an excellent low-inductance path for the return current flow.
- Placing the power plane next to the ground plane creates additional high-frequency bypass capacitance of approximately 100 pF/in².
- Routing the slower speed control signals on the bottom layer allows for greater flexibility as these signal links usually have margin to tolerate discontinuities such as vias.

If an additional supply voltage plane or signal layer is needed, add a second power and ground plane system to the stack to keep it symmetrical. This makes the stack mechanically stable and prevents it from warping. Also the power and ground plane of each power system can be placed closer together, thus increasing the high-frequency bypass capacitance significantly.

注

For detailed layout recommendations, see Application Note [SLLA284](#), *Digital Isolator Design Guide*.

10.2 Layout Example

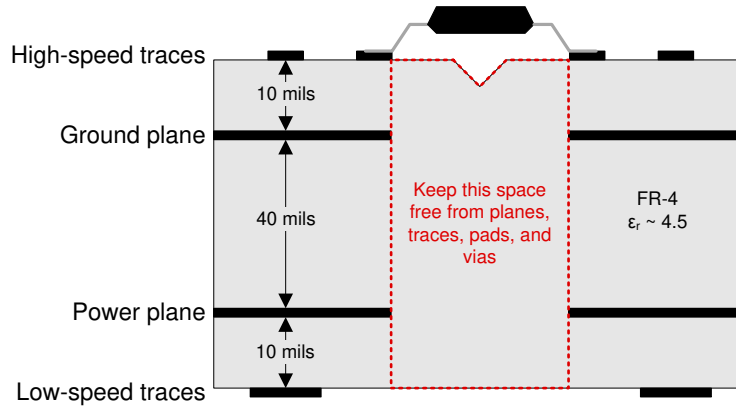

 10-1. Recommended Layer Stack

11 Device and Documentation Support

11.1 Documentation Support

11.1.1 Related Documentation

For related documentation, see the following:

- Texas Instruments, [Digital Isolator Design Guide data sheet](#)
- Texas Instruments, [Transformer Driver for Isolated Power Supplies application report](#)
- Texas Instruments, [Isolation Glossary application report](#)

11.2 ドキュメントの更新通知を受け取る方法

ドキュメントの更新についての通知を受け取るには、ti.com のデバイス製品フォルダを開いてください。「更新の通知を受け取る」をクリックして登録すると、変更されたすべての製品情報に関するダイジェストを毎週受け取れます。変更の詳細については、修正されたドキュメントに含まれている改訂履歴をご覧ください。

11.3 サポート・リソース

[TI E2E™ サポート・フォーラム](#)は、エンジニアが検証済みの回答と設計に関するヒントをエキスパートから迅速かつ直接得ることができる場所です。既存の回答を検索したり、独自の質問をしたりすることで、設計に必要な支援を迅速に得ることができます。

リンクされているコンテンツは、該当する貢献者により、現状のまま提供されるものです。これらは TI の仕様を構成するものではなく、必ずしも TI の見解を反映したものではありません。TI の[使用条件](#)を参照してください。

11.4 Trademarks

TI E2E™ is a trademark of Texas Instruments.

すべての商標は、それぞれの所有者に帰属します。

11.5 静電気放電に関する注意事項



この IC は、ESD によって破損する可能性があります。テキサス・インスツルメンツは、IC を取り扱う際には常に適切な注意を払うことを推奨します。正しい取り扱いおよび設置手順に従わない場合、デバイスを破損するおそれがあります。

ESD による破損は、わずかな性能低下からデバイスの完全な故障まで多岐にわたります。精密な IC の場合、パラメータがわずかに変化するだけで公表されている仕様から外れる可能性があるため、破損が発生しやすくなっています。

11.6 用語集

[テキサス・インスツルメンツ用語集](#) この用語集には、用語や略語の一覧および定義が記載されています。

13 Mechanical, Packaging, and Orderable Information

The following pages include mechanical, packaging, and orderable information. This information is the most current data available for the designated devices. This data is subject to change without notice and revision of this document. For browser-based versions of this data sheet, refer to the left-hand navigation.

PACKAGING INFORMATION

Orderable Device	Status (1)	Package Type	Package Drawing	Pins	Package Qty	Eco Plan (2)	Lead finish/ Ball material (6)	MSL Peak Temp (3)	Op Temp (°C)	Device Marking (4/5)	Samples
ISO15DW	OBSOLETE	SOIC	DW	16		TBD	Call TI	Call TI	-40 to 85	ISO15	
ISO15DWR	ACTIVE	SOIC	DW	16	2000	RoHS & Green	NIPDAU	Level-2-260C-1 YEAR	-40 to 85	ISO15	Samples
ISO15MDW	OBSOLETE	SOIC	DW	16		TBD	Call TI	Call TI	-55 to 125	ISO15M	
ISO15MDWR	OBSOLETE	SOIC	DW	16		TBD	Call TI	Call TI	-55 to 125	ISO15M	
ISO35DW	OBSOLETE	SOIC	DW	16		TBD	Call TI	Call TI	-40 to 85	ISO35	
ISO35DWR	ACTIVE	SOIC	DW	16	2000	RoHS & Green	NIPDAU	Level-2-260C-1 YEAR	-40 to 85	ISO35	Samples
ISO35MDW	OBSOLETE	SOIC	DW	16		TBD	Call TI	Call TI	-55 to 125	ISO35M	
ISO35MDWR	OBSOLETE	SOIC	DW	16		TBD	Call TI	Call TI	-55 to 125	ISO35M	

(1) The marketing status values are defined as follows:

ACTIVE: Product device recommended for new designs.

LIFEBUY: TI has announced that the device will be discontinued, and a lifetime-buy period is in effect.

NRND: Not recommended for new designs. Device is in production to support existing customers, but TI does not recommend using this part in a new design.

PREVIEW: Device has been announced but is not in production. Samples may or may not be available.

OBSOLETE: TI has discontinued the production of the device.

(2) **RoHS:** TI defines "RoHS" to mean semiconductor products that are compliant with the current EU RoHS requirements for all 10 RoHS substances, including the requirement that RoHS substance do not exceed 0.1% by weight in homogeneous materials. Where designed to be soldered at high temperatures, "RoHS" products are suitable for use in specified lead-free processes. TI may reference these types of products as "Pb-Free".

RoHS Exempt: TI defines "RoHS Exempt" to mean products that contain lead but are compliant with EU RoHS pursuant to a specific EU RoHS exemption.

Green: TI defines "Green" to mean the content of Chlorine (Cl) and Bromine (Br) based flame retardants meet JS709B low halogen requirements of <=1000ppm threshold. Antimony trioxide based flame retardants must also meet the <=1000ppm threshold requirement.

(3) MSL, Peak Temp. - The Moisture Sensitivity Level rating according to the JEDEC industry standard classifications, and peak solder temperature.

(4) There may be additional marking, which relates to the logo, the lot trace code information, or the environmental category on the device.

(5) Multiple Device Markings will be inside parentheses. Only one Device Marking contained in parentheses and separated by a "-" will appear on a device. If a line is indented then it is a continuation of the previous line and the two combined represent the entire Device Marking for that device.

(6) Lead finish/Ball material - Orderable Devices may have multiple material finish options. Finish options are separated by a vertical ruled line. Lead finish/Ball material values may wrap to two lines if the finish value exceeds the maximum column width.

Important Information and Disclaimer: The information provided on this page represents TI's knowledge and belief as of the date that it is provided. TI bases its knowledge and belief on information provided by third parties, and makes no representation or warranty as to the accuracy of such information. Efforts are underway to better integrate information from third parties. TI has taken and continues to take reasonable steps to provide representative and accurate information but may not have conducted destructive testing or chemical analysis on incoming materials and chemicals. TI and TI suppliers consider certain information to be proprietary, and thus CAS numbers and other limited information may not be available for release.

In no event shall TI's liability arising out of such information exceed the total purchase price of the TI part(s) at issue in this document sold by TI to Customer on an annual basis.

TAPE AND REEL INFORMATION

QUADRANT ASSIGNMENTS FOR PIN 1 ORIENTATION IN TAPE

*All dimensions are nominal

Device	Package Type	Package Drawing	Pins	SPQ	Reel Diameter (mm)	Reel Width W1 (mm)	A0 (mm)	B0 (mm)	K0 (mm)	P1 (mm)	W (mm)	Pin1 Quadrant
ISO15DWR	SOIC	DW	16	2000	330.0	16.4	10.75	10.7	2.7	12.0	16.0	Q1
ISO35DWR	SOIC	DW	16	2000	330.0	16.4	10.75	10.7	2.7	12.0	16.0	Q1

TAPE AND REEL BOX DIMENSIONS

*All dimensions are nominal

Device	Package Type	Package Drawing	Pins	SPQ	Length (mm)	Width (mm)	Height (mm)
ISO15DWR	SOIC	DW	16	2000	353.0	353.0	32.0
ISO35DWR	SOIC	DW	16	2000	353.0	353.0	32.0

GENERIC PACKAGE VIEW

DW 16

SOIC - 2.65 mm max height

7.5 x 10.3, 1.27 mm pitch

SMALL OUTLINE INTEGRATED CIRCUIT

This image is a representation of the package family, actual package may vary.
Refer to the product data sheet for package details.



4224780/A

重要なお知らせと免責事項

TI は、技術データと信頼性データ（データシートを含みます）、設計リソース（リファレンス・デザインを含みます）、アプリケーションや設計に関する各種アドバイス、Web ツール、安全性情報、その他のリソースを、欠陥が存在する可能性のある「現状のまま」提供しており、商品性および特定目的に対する適合性の黙示保証、第三者の知的財産権の非侵害保証を含むいかなる保証も、明示的または黙示的にかかわらず拒否します。

これらのリソースは、TI 製品を使用する設計の経験を積んだ開発者への提供を意図したものです。(1) お客様のアプリケーションに適した TI 製品の選定、(2) お客様のアプリケーションの設計、検証、試験、(3) お客様のアプリケーションに該当する各種規格や、その他のあらゆる安全性、セキュリティ、規制、または他の要件への確実な適合に関する責任を、お客様のみが単独で負うものとします。

上記の各種リソースは、予告なく変更される可能性があります。これらのリソースは、リソースで説明されている TI 製品を使用するアプリケーションの開発の目的でのみ、TI はその使用をお客様に許諾します。これらのリソースに関して、他の目的で複製することや掲載することは禁止されています。TI や第三者の知的財産権のライセンスが付与されている訳ではありません。お客様は、これらのリソースを自身で使用した結果発生するあらゆる申し立て、損害、費用、損失、責任について、TI およびその代理人を完全に補償するものとし、TI は一切の責任を拒否します。

TI の製品は、[TI の販売条件](#)、または [ti.com](#) やかかる TI 製品の関連資料などのいずれかを通じて提供する適用可能な条項の下で提供されています。TI がこれらのリソースを提供することは、適用される TI の保証または他の保証の放棄の拡大や変更を意味するものではありません。

お客様がいかなる追加条項または代替条項を提案した場合でも、TI はそれらに異議を唱え、拒否します。

郵送先住所：Texas Instruments, Post Office Box 655303, Dallas, Texas 75265
Copyright © 2024, Texas Instruments Incorporated